

SECTION 905 -- PROPOSAL (CONTINUED)

I (We) further propose to execute the attached contract agreement (Section 902) as soon as the work is awarded to me (us), and to begin and complete the work within the time limit(s) provided for in the Specifications and Advertisement. I (We) also propose to execute the attached contract bond (Section 903) in an amount not less than one hundred (100) percent of the total of my (our) part, but also to guarantee the excellence of both workmanship and materials until the work is finally accepted.

I (We) enclose a certified check, cashier's check or bid bond for **five percent (5%) of total bid** and hereby agree that in case of my (our) failure to execute the contract and furnish bond within Ten (10) days after notice of award, the amount of this check (bid bond) will be forfeited to the State of Mississippi as liquidated damages arising out of my (our) failure to execute the contract as proposed. It is understood that in case I am (we are) not awarded the work, the check will be returned as provided in the Specifications.

Bidder acknowledges receipt of and has added to and made a part of the proposal and contract documents the following addendum (addenda):

ADDENDUM NO. 1 DATED 6/13/2008 ADDENDUM NO. DATED
 ADDENDUM NO. DATED ADDENDUM NO. DATED

Number	Description
1	Advertisement, replaces same; Revised NTB 2001, replaces same; Revised Bid Bond, replaces same; Amendment EBS Download Required.

TOTAL ADDENDA: 1
 (Must agree with total addenda issued prior to opening of bids)

Respectfully Submitted,

DATE _____

 Contractor

BY _____
 Signature

TITLE _____

ADDRESS _____

CITY, STATE, ZIP _____

PHONE _____

FAX _____

E-MAIL _____

(To be filled in if a corporation)

Our corporation is chartered under the Laws of the State of _____ and the names, titles and business addresses of the executives are as follows:

_____ President	_____ Address
_____ Secretary	_____ Address
_____ Treasurer	_____ Address

The following is my (our) itemized proposal.

MISSISSIPPI DEPARTMENT OF TRANSPORTATION

SECTION 901 - ADVERTISEMENT

Sealed bids will be received by the Mississippi Transportation Commission in the Office of the Contract Administration Engineer, Room 1013, Mississippi Department of Transportation Administration Building, 401 North West Street, Jackson, Mississippi, until 9:30 o'clock A.M., Tuesday, June 24, 2008; thereafter, bids will be received in the First Floor Auditorium of the Mississippi Department of Transportation Administration Building, Jackson, Mississippi, until 10:00 o'clock A.M., Tuesday, June 24, 2008, and shortly thereafter publicly opened for:

Mill and Overlay US 11 at Hattiesburg, known as State Project No. MP-6011-18(007) / 303437301, in the County of Forrest, State of Mississippi.

The attention of bidders is directed to the Contract Provisions governing selection and employment of labor. Minimum wage rates have been predetermined by the Secretary of Labor and are subject to Public Law 87-58 1, Work Hours Act of 1962, as set forth in the Contract Provisions.

The Mississippi Department of Transportation hereby notifies all bidders that it will affirmatively insure that in any contract entered into pursuant to this advertisement, disadvantaged business enterprises will be afforded full opportunity to submit bids in response to this invitation and will not be discriminated against on the grounds of race, color, sex, age, disability, religion or national origin in consideration for an award.

The award of this contract will be contingent upon the Contractor satisfying the DBE requirements.

The specifications are on file in the offices of the Mississippi Department of Transportation.

Bid proposals must be acquired from the MDOT Contract Administration Division. These proposals are available at a cost of Ten Dollars (\$10.00) per proposal. Specimen proposals are also available at the MDOT Contract Administration Division at a cost of Ten Dollars (\$10.00) per proposal, or can be viewed or downloaded at no cost at www.gomdot.com.

Bid bond, signed or countersigned by a Mississippi Resident Agent, with Power of Attorney attached or on file with the Contract Administration Engineer of the Department, a Cashier's check or Certified Check for five (5%) percent of bid, payable to STATE OF MISSISSIPPI, must accompany each proposal.

The attention of bidders is directed to the provisions of Subsection 102.07 pertaining to irregular proposals and rejection of bids.

LARRY L. "BUTCH" BROWN
EXECUTIVE DIRECTOR

MISSISSIPPI DEPARTMENT OF TRANSPORTATION

SECTION 904 - NOTICE TO BIDDERS NO. 2001

CODE: (SP)

DATE: 06/13/2008

SUBJECT: Scope Of Work

PROJECT: MP-6011-18(007) / 303437301 -- Forrest County

The contract documents do not include an official set of construction plans but may, by reference, include some Standard Drawings when so specified in a Notice to Bidders entitled, "Standard Drawings". All other references to plans in the contract documents and Standard Specifications for Road and Bridge Construction are to be disregarded.

Work on the project shall consist of the following:

US HIGHWAY 11 OVERLAY 1.4 MILES OF US HWY 11 FROM APPROXIMATELY 400' NORTH OF LINCOLN ROAD TO END OF STATE MAINTENANCE

Mill the roadway 1½" and variable on a 2% cross slope, including ramp tie-ins and local streets, and overlay with 1½" of 9.5mm HT hot mix asphalt.

ASPHALT NOTES:

- The section from the B.O.P. to the end of the median island shall be milled on a uniform cross slope that matches the existing curb. All sections of the roadway from the end of the median island to the E.O.P. shall be milled to a 2% cross slope.
- Asphalt shall be placed on the milled surface within 48 hours of milling
- Publicly maintained streets shall be milled and overlaid to the existing R.O.W.
- All ramps shall be milled and overlaid to the limits of the existing overlay.
- All base failures shall be removed and replaced with 9.5mm HT hot mix asphalt. 100 SY of pavement removal have been provided in the contract for the removal of concrete or asphalt pavement.

GENERAL NOTES:

- All Transverse Joints shall be sawed and sealed after the overlay (See Typical Drawing).
- Temporary striping shall conform to finished stripe specifications for alignment, neatness, reflectivity, and straightness. All permanent edge pavement markings on asphalt are to be

hot thermoplastic. Glass beads applied to thermoplastic shall conform to Subsection 720.01 (Beads shall be double dropped, Class B High Visibility first and then Class A Standard Visibility).

- Raised pavement markers will be placed at 40 feet intervals in along the centerline of roadway. Any removal of existing raised pavement markers shall be considered an absorbed item.
- The contractor shall erect and maintain construction signing, and provide all signs and traffic handling devices in accordance with Manual Uniform Traffic Control Devices (MUTCD) (the cost is to be included in the price bid for pay item No. 618-A, Maintenance of Traffic).
- All vehicle loop assemblies shall be replaced as per the following chart:

Vehicle Loop Assemblies

Bartur Street			Timothy Lane			Florence Avenue		
Phase	Size	Quantity	Phase	Size	Quantity	Phase	Size	Quantity
2A	50' x 6'	162 LF	2A	50' x 6'	162 LF	2A	50' x 6'	162 LF
2B	50' x 6'	162 LF	2B	50' x 6'	162 LF	2B	50' x 6'	162 LF
6A	50' x 6'	162 LF	6A	50' x 6'	162 LF	6A	50' x 6'	162 LF
6B	50' x 6'	162 LF	6B	50' x 6'	162 LF	6B	50' x 6'	162 LF
1	50' x 6'	162 LF	1	50' x 6'	162 LF	1	50' x 6'	162 LF
5	50' x 6'	162 LF	5	50' x 6'	162 LF	5	50' x 6'	162 LF
4	50' x 6'	162 LF	4	50' x 6'	162 LF	4	50' x 6'	162 LF
8	20' x 6'	72 LF	8	50' x 6'	162 LF	8	50' x 6'	162 LF
7	50' x 6'	162 LF	7	50' x 6'	162 LF			
			3	50' x 6'	162 LF			
Total = 1,368 LF			Total = 1,620 LF			Total = 1,296 LF		

STATE	PROJECT NO.
MISS.	

TYPICAL FOR RAISED PAVEMENT MARKERS PLACED ON SIDE ROAD RADIUS

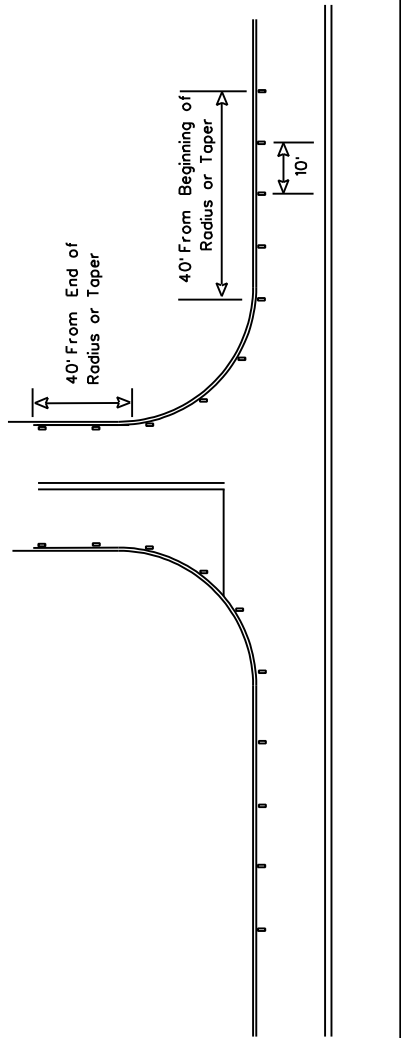

- NOTE 1. MARKERS SHALL BE PLACED EVERY 10 FEET.
- NOTE 2. MARKERS SHALL BE VISIBLE FROM THE TRAVELING MOTORIST ON STATE DESIGNATED HIGHWAYS.
- NOTE 3. MARKERS SHALL BE HIGH PERFORMANCE TWO WAY CLEAR.
- NOTE 4. FIVE (5) MARKERS SHALL BE PLACED ALONG MAINLINE EDGE STRIPE.
- NOTE 5. MARKERS FOR COUNTY ROADS SHALL CONTINUE DOWN THE EDGE STRIPE A DISTANCE OF 40 FEET.

MISSISSIPPI DEPARTMENT OF TRANSPORTATION	
2 - LANE	
2-WAY CLEAR RAISED PAVEMENT MARKERS PLACED ON SIDE ROADS	
DATE	WORKING NUMBER
BY	
REVISION	
FILE NAME	SHEET NUMBER
DESIGN TITLE	PROJECT
	DIST.

STATE	PROJECT NO.
MSS.	

TYPICAL FOR RAISED PAVEMENT MARKERS PLACED ON SIDE ROAD RADIUS

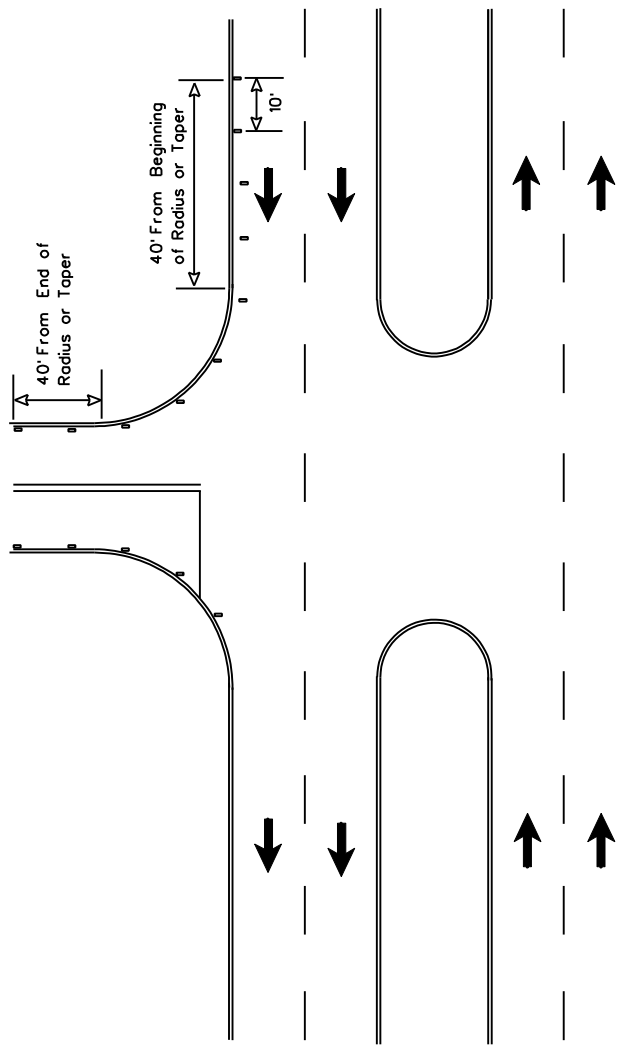

- NOTE 1. MARKERS SHALL BE PLACED EVERY 10 FEET.
- NOTE 2. MARKERS SHALL BE VISIBLE FROM THE TRAVELING MOTORIST ON STATE DESIGNATED HIGHWAYS.
- NOTE 3. MARKERS SHALL BE HIGH PERFORMANCE TWO WAY CLEAR.
- NOTE 4. CHANNELIZED INTERSECTIONS WILL REQUIRE MORE MARKERS THAN STANDARD INTERSECTIONS DUE TO LONGER TAPER.
- NOTE 5. FIVE (5) MARKERS SHALL BE PLACED ON MAINLINE EDGE STRIPE.
- NOTE 6. MARKERS FOR COUNTY ROADS SHALL CONTINUE DOWN THE EDGE STRIPE A DISTANCE OF 40 FEET.

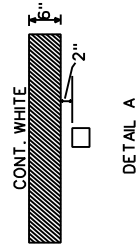

MISSISSIPPI DEPARTMENT OF TRANSPORTATION	
4-LANE	
2-WAY CLEAR RAISED PAVEMENT MARKERS PLACED ON SIDE ROADS	
BY	REVISION
DATE	
FILE NAME:	CHECKED:
PERSON:	DATE:
WORKING NUMBER:	SHEET NUMBER:

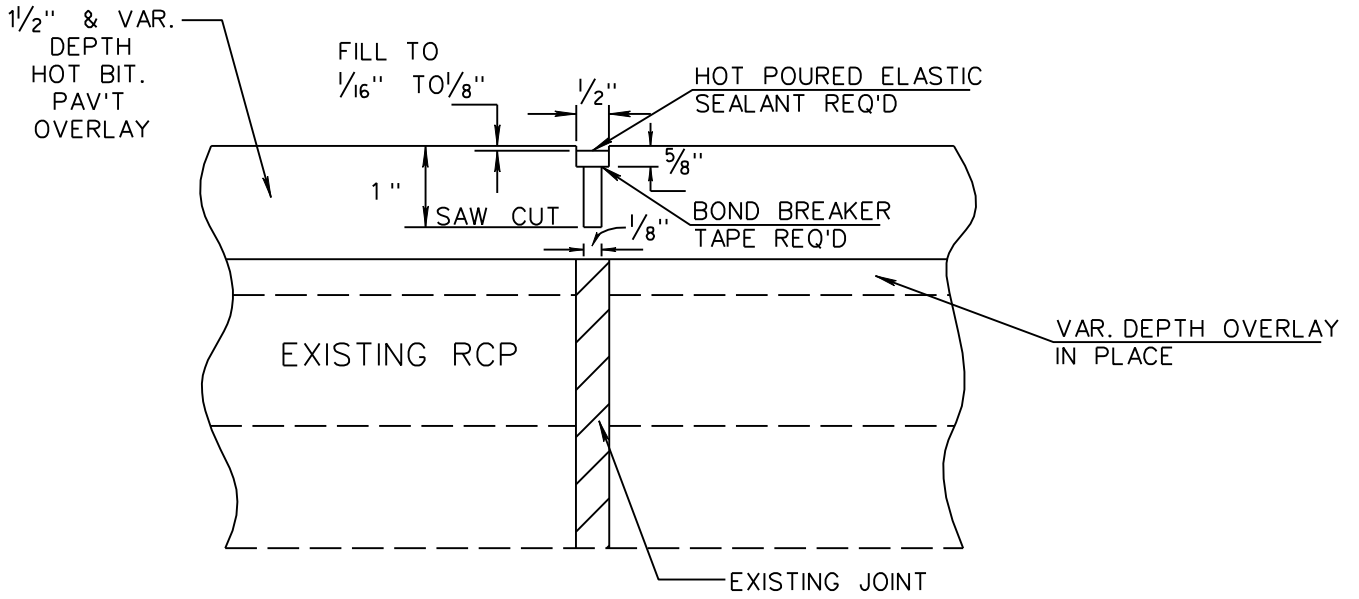

DETAIL OF SAWING AND SEALING TRANSVERSE JOINTS

SR 969 (EDWARDS STREET)



BID BOND

KNOW ALL MEN BY THESE PRESENTS, that we _____
Contractor

Address

City, State ZIP

as Principal, hereinafter called the Principal, and _____

a corporation duly organized under the laws of the state of _____

as Surety, hereinafter called the Surety, are held and firmly bound unto State of Mississippi, Jackson, Mississippi

As Obligee, hereinafter called Obligee, in the sum of **Five Per Cent (5%) of Amount Bid**
Dollars (\$ _____)

for the payment of which sum will and truly to be made, the said Principal and said Surety, bind ourselves, our heirs, executors, administrators, successors and assigns, jointly and severally, firmly by these presents.

WHEREAS, the Principal has submitted a bid for **Mill and Overlay US 11 at Hattiesburg, known as State Project No. MP-6011-18(007) / 303437301, in the County of Forrest, State of Mississippi.**

NOW THEREFORE, the condition of this obligation is such that if the aforesaid Principal shall be awarded the contract, the said Principal will, within the time required, enter into a formal contract and give a good and sufficient bond to secure the performance of the terms and conditions of the contract, then this obligation to be void; otherwise the Principal and Surety will pay unto the Obligee the difference in money between the amount of the bid of the said Principal and the amount for which the Obligee legally contracts with another party to perform the work if the latter amount be in excess of the former, but in no event shall liability hereunder exceed the penal sum hereof.

Signed and sealed this _____ day of _____, 2008

(Principal) (Seal)

(Witness)

By: _____
(Title)

(Surety) (Seal)

(Witness)

By: _____
(Attorney-in-Fact)

Resident MS Agent

Bid bond must be signed or countersigned by a qualified Mississippi resident agent and the bidder as per Section 102.08 of the Mississippi Standard Specifications for Road and Bridge Construction, 2004 edition.