

SECTION 905 -- PROPOSAL (CONTINUED)

I (We) further propose to execute the attached contract agreement (Section 902) as soon as the work is awarded to me (us), and to begin and complete the work within the time limit(s) provided for in the Specifications and Advertisement. I (We) also propose to execute the attached contract bond (Section 903) in an amount not less than one hundred (100) percent of the total of my (our) part, but also to guarantee the excellence of both workmanship and materials until the work is finally accepted.

I (We) enclose a certified check, cashier's check or bid bond for **five percent (5%) of total bid** and hereby agree that in case of my (our) failure to execute the contract and furnish bond within Ten (10) days after notice of award, the amount of this check (bid bond) will be forfeited to the State of Mississippi as liquidated damages arising out of my (our) failure to execute the contract as proposed. It is understood that in case I am (we are) not awarded the work, the check will be returned as provided in the Specifications.

Bidder acknowledges receipt of and has added to and made a part of the proposal and contract documents the following addendum (addenda):

ADDENDUM NO. 1 DATED 8/16/2010 ADDENDUM NO. DATED
 ADDENDUM NO. DATED ADDENDUM NO. DATED

Number	Description
1	Revised NTB 3144; Wage Rates, replace same; Bidsheets, replace same; Amendment EBS Download Required.

TOTAL ADDENDA: 1
 (Must agree with total addenda issued prior to opening of bids)

Respectfully Submitted,

DATE _____

 Contractor

BY _____
 Signature

TITLE _____

ADDRESS _____

CITY, STATE, ZIP _____

PHONE _____

FAX _____

E-MAIL _____

(To be filled in if a corporation)

Our corporation is chartered under the Laws of the State of _____ and the names, titles and business addresses of the executives are as follows:

_____ President	_____ Address
_____ Secretary	_____ Address
_____ Treasurer	_____ Address

The following is my (our) itemized proposal.

Revised 09/21/2005

MDPS-0000-03(004) / 105962303

Districtwide(3) County(ies)

MISSISSIPPI DEPARTMENT OF TRANSPORTATION

SECTION 904 – NOTICE TO BIDDERS NO. 3144

CODE: (SP)

DATE: 08/16/2010

SUBJECT: Scope Of Work

PROJECT: MDPS-0000-03(004) / 105962303 – District 3

The contract documents do not include an official set of construction plans, but may by reference, include some Standard Drawings or Special Design Drawings. All other references to plans in the contract documents and Standard Specifications for Road and Bridge Construction are to be disregarded.

Work on the project shall consist of the following:

Guardrail

Remove and replace guardrail at various locations throughout District . The specific locations and quantities are shown on the following sheets. The guardrail, including the applicable bridge end sections, terminal end sections, object markers, delineators, etc., shall be placed in accordance with the Standard Drawings, unless otherwise specified by the Engineer. The pay item for removal of guardrail shall include the bridge end sections, posts, terminal end sections, cable anchors, etc.

Earthwork

Where applicable, the existing shoulders and/or bridge approach embankments are to be widened to conform to the requirements of the Standard Drawings unless otherwise directed. This work will be accomplished by building up the slopes with borrow material. The slopes will be modified on the taper area adjacent to the terminal end section and blended into the existing slope as required.

Erosion Control

Erosion control practices (silt fence and wattles.) shall be utilized to prevent the loss of loose material at all areas that are disturbed. Solid Sod will be required on all disturbed areas. The sodding shall be accomplished in accordance with the Standard Specifications. Areas to be sodded shall be graded to the satisfaction of the Engineer prior to the commencement of sodding activities. Sodding operation shall be done immediately after completing the dirtwork operations in order to minimize potential erosion. The contractor's erosion control plan as outlined in Special Provision 907-107-9 shall be submitted on the attached ECP sheets for guardrail installation.

Miscellaneous

It shall be the responsibility of the Contractor to protect existing structures such as pipes, inlets, aprons, paved ditches, bridges, fences, etc. from damage which might occur during construction. The Contractor shall replace or repair, as directed by the Engineer, any structures damaged during the life of the Contract. No payment will be made for replacement or repair of damaged items.

Any signs that are in conflict with construction of this project shall be removed and replaced/relocated by the Contractor as directed by the Engineer. The cost of removal, storage, and replacement of signs is to be absorbed in other items bid. No separate payment will be made for the removal of object markers.

Incidental work such as removing vegetation, removing and resetting signs, shaping and compacting shoulders, removing excess asphalt material, project clean-up, and other incidental work necessary to complete the project will not be measured for separate payment and will be considered included in the prices of items bid.

It shall be the responsibility of the contractor to verify the types of bridge end sections and special connectors prior to ordering materials.

The contractor shall coordinate construction activities to ensure that all guardrail, including terminal end sections and bridge end sections, taken down be replaced the same day. In the event that the guardrail, including terminal end sections and bridge end sections, is not replaced the same day, the contractor shall place median barriers to ensure the safety of the traveling public. All costs shall be absorbed by the contractor.

The cost of any clearing or staking that may be necessary shall be absorbed in other items bid.

The contractor shall provide all construction signs and traffic handling devices necessary to safely maintain traffic around or through the work area. The G20-1 and W20-1 signs will not be required under this contract. All cost for construction signs shall be absorbed under Pay Item 618-A, Maintenance of Traffic.

Site #	County	Bridge #	Route	Feature	Location	No. and Type Br. End Sect.	Terminal End Sect. Non-flared	Guardrail	Removal	Borrow	Sod	Object Markers
1	Holmes	69.20	SR 14	I-55	SR 14 Over I-55	(4) D Mod.	4	400	300	750	4,840	4
2	Holmes	149.00	St. Park Rd	I-55	3.6 MI N SR 14	(4) D Mod.	4	400	300	750	4,840	4
3	Sunflower	31.20	SR 8	Quiver River	2.3 MI E US 49W	(4) A Mod.	4	400	300	750	4,840	4
4	Issaquena	6.60	SR 14	Steel Bayou East Pr.	0.6 MI E SR 1 NORTH	(4) G Mod.	4	400	300	750	7,260	4
5	Issaquena	4.70	SR 1	Steel Bayou	0.1 MI S SR 465	(4) D Mod.	4	400	300	750	4,840	4
6	Warren	126.50	SR 27	KCS RR	1.4 MI S US 80	(4) A	4	400	300	2000	12,100	4
7	Claiborne	10.40	SR 18	Creek Branch	1.4 MI E SR 548	(4) A	4	400	300	3100	14,520	4
8	Claiborne	13.10	SR 18	Storm Creek	3.9 MI E SR 548	(4) A	4	400	300	3000	14,520	4
9	Claiborne	17.40	SR 18	Choctaw Creek	8.0 MI E SR 548	(4) G Mod.	4	400	300	3200	14,520	4
						Each	Each	LF	LF	CY	SY	Each

Note: The Type "A" Bridge End Sections will have a Bridge Connector.

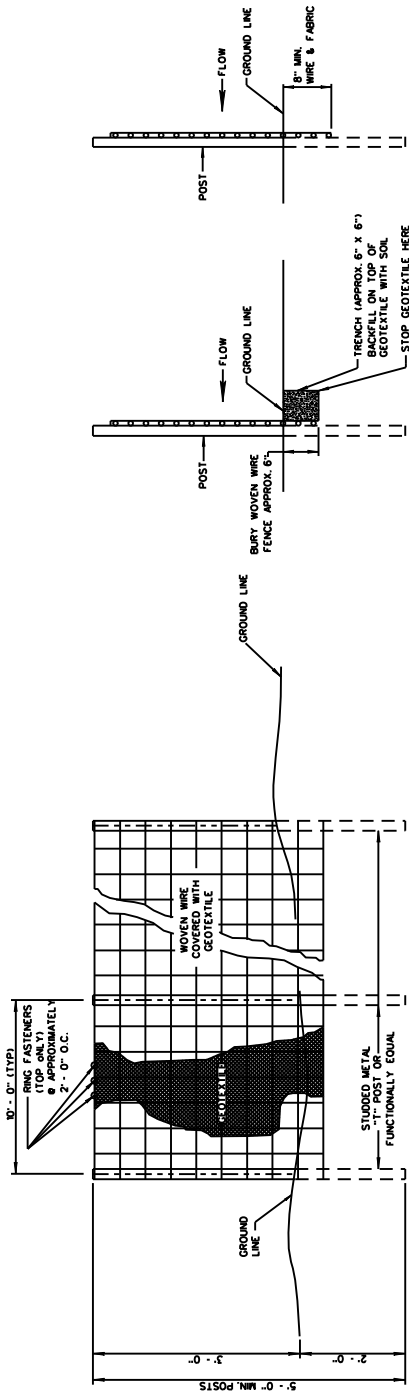

ELEVATION VIEW

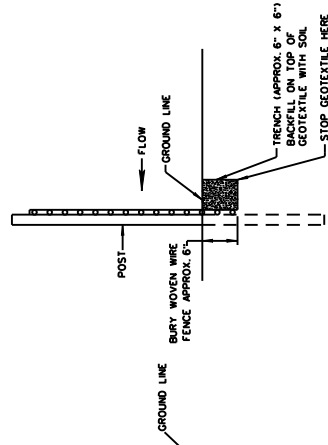

METHOD I

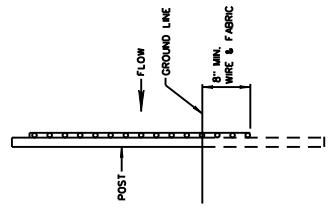

METHOD II
MECHANICAL INSTALLATION

- NOTES:
1. SILT FENCES SHALL BE USED IN AREAS WHERE FLOW IS NOT SEVERE. FENCES ARE NOT TO BE USED IN AREAS WHERE FLOW IS SEVERE.
 2. OPPOSITE SLOPE AREAS SUCH AS NEARLY GRADED FALL SLOPES AND ADJACENT TO STREAMS AND CHANNELS.
 3. SILT FENCE SHOULD BE PLACED WELL INSIDE RIGHT-OF-WAY AND ALONG EDGE OF CLEARING LIMITS. THIS WILL ALLOW ROOM FOR A BACK-UP FENCE IF FIRST FENCE BECOMES THE SHAPE OF A SMOLE. THIS ADS IN PONDING OF RUNOFF AND FACILITATES SEEDING.
 4. WHEREVER POSSIBLE SILT FENCE SHALL BE CONSTRUCTED ACROSS A LEVEL AREA IN ORDER TO PREVENT PONDING.
 5. COST TO BE LINEAR FEET OF SILT FENCE.
 6. METHOD INSTALLATION SHALL BE ACCOMPLISHED USING AN IMPLEMENT THAT IS MANUFACTURED FOR THE APPLICATION AND PROVIDES A CONFIGURATION MEETING THE REQUIREMENTS OF THE DETAILS.
 7. WOVEN WIRE SHALL BE 32" IN WIDTH AND SHALL HAVE A MINIMUM OF 6 LINE WIRES WITH 12" STAY SPACING.
 8. GEOTEXTILE FABRIC MEETING THE TYPE II MATERIAL REQUIREMENTS AND INSTALLED ACCORDING TO SPECIFICATION MAY BE USED WITHOUT WIRE FENCE.

SIDE VIEW

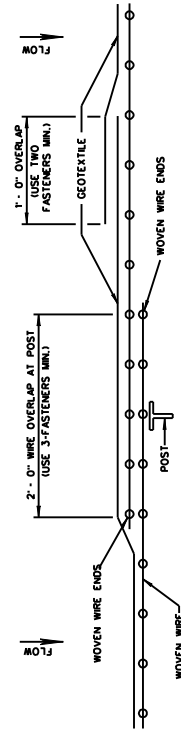

PLAN VIEW
REQUIRED LAPPING

MISSISSIPPI DEPARTMENT OF TRANSPORTATION	
DETAILS OF SILT FENCE INSTALLATION	
NO. 1	NO. 2
NO. 3	NO. 4
NO. 5	NO. 6
NO. 7	NO. 8
NO. 9	NO. 10
NO. 11	NO. 12
NO. 13	NO. 14
NO. 15	NO. 16
NO. 17	NO. 18
NO. 19	NO. 20
NO. 21	NO. 22
NO. 23	NO. 24
NO. 25	NO. 26
NO. 27	NO. 28
NO. 29	NO. 30
NO. 31	NO. 32
NO. 33	NO. 34
NO. 35	NO. 36
NO. 37	NO. 38
NO. 39	NO. 40
NO. 41	NO. 42
NO. 43	NO. 44
NO. 45	NO. 46
NO. 47	NO. 48
NO. 49	NO. 50
NO. 51	NO. 52
NO. 53	NO. 54
NO. 55	NO. 56
NO. 57	NO. 58
NO. 59	NO. 60
NO. 61	NO. 62
NO. 63	NO. 64
NO. 65	NO. 66
NO. 67	NO. 68
NO. 69	NO. 70
NO. 71	NO. 72
NO. 73	NO. 74
NO. 75	NO. 76
NO. 77	NO. 78
NO. 79	NO. 80
NO. 81	NO. 82
NO. 83	NO. 84
NO. 85	NO. 86
NO. 87	NO. 88
NO. 89	NO. 90
NO. 91	NO. 92
NO. 93	NO. 94
NO. 95	NO. 96
NO. 97	NO. 98
NO. 99	NO. 100

WORKING NUMBER	ECD-13
SHEET NUMBER	
FILE NAME	EROSION CONTROL.ecd-3.dgn
DATE	04/08/08 12:00

STATE	PROJECT NO.
MSS.	

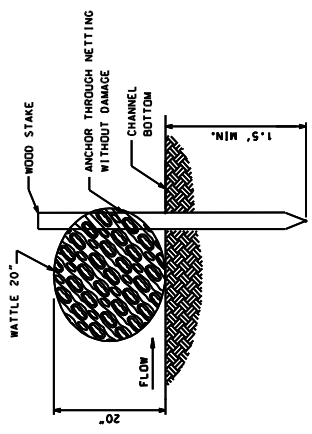
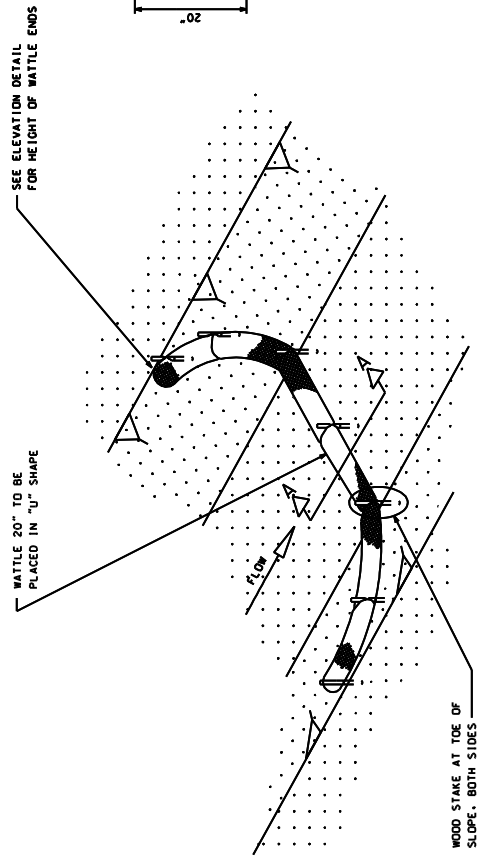

SECTION A-A

- NOTES:**
1. MINIMUM RECOMMENDED PLACEMENT INTERVAL BETWEEN WATTLE DITCH CHECK IS 100' UNLESS SHOWN OTHERWISE ON THE PLANS OR EROSION CONTROL PLAN APPROVED BY THE ENGINEER. SEE SPACING GUIDANCE ON ECD-4
 2. ANCHORING WOOD STAKES SHALL BE SIZED, SPACED, DRIVEN, AND BE OF A MATERIAL THAT EFFECTIVELY SECURES THE CHECK. STAKE SPACING SHALL BE A MAXIMUM OF THREE FEET. ALL NON-DEGRADABLE MATERIALS SHALL BE REMOVED WHEN NO LONGER NEEDED.
 3. TRENCING OF WATTLES MAY BE NECESSARY IF PIPING BECOMES EVIDENT.
 4. WATTLES SHOULD NOT BE USED IN HARD BOTTOM CHANNELS.

DETAIL (DITCH CHECK)

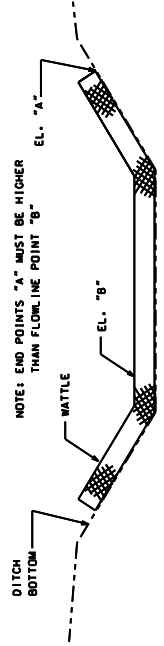

ELEVATION DETAIL

WATTLE DITCH CHECK SELECTION GUIDELINES

WATTLE DITCH CHECKS ARE APPROPRIATE FOR VELOCITY REDUCTION AND CONTROL OF SEDIMENT TRANSPORT UNDER LOW TO MEDIUM FLOW CONDITIONS.

MISSISSIPPI DEPARTMENT OF TRANSPORTATION	
DETAILS OF EROSION CONTROL	
WATTLE DITCH CHECK	
NO. 1	REVISION
NO. 2	
NO. 3	
NO. 4	
NO. 5	
NO. 6	
NO. 7	
NO. 8	
NO. 9	
NO. 10	
NO. 11	
NO. 12	
NO. 13	
NO. 14	
NO. 15	
NO. 16	
NO. 17	
NO. 18	
NO. 19	
NO. 20	
NO. 21	
NO. 22	
NO. 23	
NO. 24	
NO. 25	
NO. 26	
NO. 27	
NO. 28	
NO. 29	
NO. 30	
NO. 31	
NO. 32	
NO. 33	
NO. 34	
NO. 35	
NO. 36	
NO. 37	
NO. 38	
NO. 39	
NO. 40	
NO. 41	
NO. 42	
NO. 43	
NO. 44	
NO. 45	
NO. 46	
NO. 47	
NO. 48	
NO. 49	
NO. 50	
NO. 51	
NO. 52	
NO. 53	
NO. 54	
NO. 55	
NO. 56	
NO. 57	
NO. 58	
NO. 59	
NO. 60	
NO. 61	
NO. 62	
NO. 63	
NO. 64	
NO. 65	
NO. 66	
NO. 67	
NO. 68	
NO. 69	
NO. 70	
NO. 71	
NO. 72	
NO. 73	
NO. 74	
NO. 75	
NO. 76	
NO. 77	
NO. 78	
NO. 79	
NO. 80	
NO. 81	
NO. 82	
NO. 83	
NO. 84	
NO. 85	
NO. 86	
NO. 87	
NO. 88	
NO. 89	
NO. 90	
NO. 91	
NO. 92	
NO. 93	
NO. 94	
NO. 95	
NO. 96	
NO. 97	
NO. 98	
NO. 99	
NO. 100	
NO. 101	
NO. 102	
NO. 103	
NO. 104	
NO. 105	
NO. 106	
NO. 107	
NO. 108	
NO. 109	
NO. 110	
NO. 111	
NO. 112	
NO. 113	
NO. 114	
NO. 115	
NO. 116	
NO. 117	
NO. 118	
NO. 119	
NO. 120	
NO. 121	
NO. 122	
NO. 123	
NO. 124	
NO. 125	
NO. 126	
NO. 127	
NO. 128	
NO. 129	
NO. 130	
NO. 131	
NO. 132	
NO. 133	
NO. 134	
NO. 135	
NO. 136	
NO. 137	
NO. 138	
NO. 139	
NO. 140	
NO. 141	
NO. 142	
NO. 143	
NO. 144	
NO. 145	
NO. 146	
NO. 147	
NO. 148	
NO. 149	
NO. 150	
NO. 151	
NO. 152	
NO. 153	
NO. 154	
NO. 155	
NO. 156	
NO. 157	
NO. 158	
NO. 159	
NO. 160	
NO. 161	
NO. 162	
NO. 163	
NO. 164	
NO. 165	
NO. 166	
NO. 167	
NO. 168	
NO. 169	
NO. 170	
NO. 171	
NO. 172	
NO. 173	
NO. 174	
NO. 175	
NO. 176	
NO. 177	
NO. 178	
NO. 179	
NO. 180	
NO. 181	
NO. 182	
NO. 183	
NO. 184	
NO. 185	
NO. 186	
NO. 187	
NO. 188	
NO. 189	
NO. 190	
NO. 191	
NO. 192	
NO. 193	
NO. 194	
NO. 195	
NO. 196	
NO. 197	
NO. 198	
NO. 199	
NO. 200	
NO. 201	
NO. 202	
NO. 203	
NO. 204	
NO. 205	
NO. 206	
NO. 207	
NO. 208	
NO. 209	
NO. 210	
NO. 211	
NO. 212	
NO. 213	
NO. 214	
NO. 215	
NO. 216	
NO. 217	
NO. 218	
NO. 219	
NO. 220	
NO. 221	
NO. 222	
NO. 223	
NO. 224	
NO. 225	
NO. 226	
NO. 227	
NO. 228	
NO. 229	
NO. 230	
NO. 231	
NO. 232	
NO. 233	
NO. 234	
NO. 235	
NO. 236	
NO. 237	
NO. 238	
NO. 239	
NO. 240	
NO. 241	
NO. 242	
NO. 243	
NO. 244	
NO. 245	
NO. 246	
NO. 247	
NO. 248	
NO. 249	
NO. 250	
NO. 251	
NO. 252	
NO. 253	
NO. 254	
NO. 255	
NO. 256	
NO. 257	
NO. 258	
NO. 259	
NO. 260	
NO. 261	
NO. 262	
NO. 263	
NO. 264	
NO. 265	
NO. 266	
NO. 267	
NO. 268	
NO. 269	
NO. 270	
NO. 271	
NO. 272	
NO. 273	
NO. 274	
NO. 275	
NO. 276	
NO. 277	
NO. 278	
NO. 279	
NO. 280	
NO. 281	
NO. 282	
NO. 283	
NO. 284	
NO. 285	
NO. 286	
NO. 287	
NO. 288	
NO. 289	
NO. 290	
NO. 291	
NO. 292	
NO. 293	
NO. 294	
NO. 295	
NO. 296	
NO. 297	
NO. 298	
NO. 299	
NO. 300	
NO. 301	
NO. 302	
NO. 303	
NO. 304	
NO. 305	
NO. 306	
NO. 307	
NO. 308	
NO. 309	
NO. 310	
NO. 311	
NO. 312	
NO. 313	
NO. 314	
NO. 315	
NO. 316	
NO. 317	
NO. 318	
NO. 319	
NO. 320	
NO. 321	
NO. 322	
NO. 323	
NO. 324	
NO. 325	
NO. 326	
NO. 327	
NO. 328	
NO. 329	
NO. 330	
NO. 331	
NO. 332	
NO. 333	
NO. 334	
NO. 335	
NO. 336	
NO. 337	
NO. 338	
NO. 339	
NO. 340	
NO. 341	
NO. 342	
NO. 343	
NO. 344	
NO. 345	
NO. 346	
NO. 347	
NO. 348	
NO. 349	
NO. 350	
NO. 351	
NO. 352	
NO. 353	
NO. 354	
NO. 355	
NO. 356	
NO. 357	
NO. 358	
NO. 359	
NO. 360	
NO. 361	
NO. 362	
NO. 363	
NO. 364	
NO. 365	
NO. 366	
NO. 367	
NO. 368	
NO. 369	
NO. 370	
NO. 371	
NO. 372	
NO. 373	
NO. 374	
NO. 375	
NO. 376	
NO. 377	
NO. 378	
NO. 379	
NO. 380	
NO. 381	
NO. 382	
NO. 383	
NO. 384	
NO. 385	
NO. 386	
NO. 387	
NO. 388	
NO. 389	
NO. 390	
NO. 391	
NO. 392	
NO. 393	
NO. 394	
NO. 395	
NO. 396	
NO. 397	
NO. 398	
NO. 399	
NO. 400	
NO. 401	
NO. 402	
NO. 403	
NO. 404	
NO. 405	
NO. 406	
NO. 407	
NO. 408	
NO. 409	
NO. 410	
NO. 411	
NO. 412	
NO. 413	
NO. 414	
NO. 415	
NO. 416	
NO. 417	
NO. 418	
NO. 419	
NO. 420	
NO. 421	
NO. 422	
NO. 423	
NO. 424	
NO. 425	
NO. 426	
NO. 427	
NO. 428	
NO. 429	
NO. 430	
NO. 431	
NO. 432	
NO. 433	
NO. 434	
NO. 435	
NO. 436	
NO. 437	
NO. 438	
NO. 439	
NO. 440	
NO. 441	
NO. 442	
NO. 443	
NO. 444	
NO. 445	
NO. 446	
NO. 447	
NO. 448	
NO. 449	
NO. 450	
NO. 451	
NO. 452	
NO. 453	
NO. 454	
NO. 455	
NO. 456	
NO. 457	
NO. 458	
NO. 459	
NO. 460	
NO. 461	
NO. 462	
NO. 463	
NO. 464	
NO. 465	
NO. 466	
NO. 467	
NO. 468	
NO. 469	
NO. 470	
NO. 471	
NO. 472	
NO. 473	
NO. 474	
NO. 475	

General Decision Number: MS100203 07/02/2010 MS203

Superseded General Decision Number: MS20080203

State: Mississippi

Construction Type: Highway

Counties: Amite, Covington, Issaquena, Jefferson Davis, Lawrence, Lincoln, Marion, Sharkey, Walthall and Warren Counties in Mississippi.

HIGHWAY CONSTRUCTION PROJECTS (excluding tunnels, building structures in rest area projects & railroad construction; bascule, suspension & spandrel arch bridges designed for commercial navigation, bridges involving marine construction; and other major bridges).

Modification Number	Publication Date
0	03/12/2010
1	06/04/2010
2	07/02/2010

* ELEC0480-008 07/01/2010

Amite, Covington, Issaquena, Lawrence, Lincoln, Sharkey, Walthall, and Warren Counties

	Rates	Fringes
ELECTRICIAN.....	\$ 22.60	8.11

ELEC0903-010 06/01/2010

Jefferson Davis and Marion Counties

	Rates	Fringes
ELECTRICIAN.....	\$ 23.60	6.83

SUMS2008-121 09/04/2008

	Rates	Fringes
CARPENTER, Including Form Work...	\$ 11.42	0.12
CEMENT MASON/CONCRETE FINISHER...	\$ 10.82	0.00
IRONWORKER, REINFORCING.....	\$ 11.30	0.00
LABORER: Common or General.....	\$ 8.64	0.00
LABORER: Pipelayer.....	\$ 9.68	0.00
OPERATOR: Backhoe/Excavator.....	\$ 11.32	0.00
OPERATOR: Broom.....	\$ 10.17	0.00
OPERATOR: Bulldozer.....	\$ 10.77	0.00
OPERATOR: Crane.....	\$ 14.57	0.00

OPERATOR: Grader/Blade.....	\$ 12.46	0.00
OPERATOR: Loader.....	\$ 10.15	0.00
OPERATOR: Mechanic.....	\$ 12.04	0.00
OPERATOR: Oiler.....	\$ 12.33	0.48
OPERATOR: Roller.....	\$ 9.31	0.00
OPERATOR: Scraper.....	\$ 10.00	0.00
OPERATOR: Tractor.....	\$ 7.79	0.00
OPERATOR: Asphalt Paver and Asphalt Spreader.....	\$ 10.00	0.00
TRUCK DRIVER.....	\$ 9.22	0.00

WELDERS - Receive rate prescribed for craft performing
operation to which welding is incidental.
=====

Unlisted classifications needed for work not included within
the scope of the
classifications listed may be added after award only as
provided in the labor
standards contract clauses (29 CFR 5.5(a)(1)(ii)).

--

In the listing above, the "SU" designation means that rates
listed under the
identifier do not reflect collectively bargained wage and
fringe benefit
rates. Other designations indicate unions whose rates have
been determined
to be prevailing.

--

WAGE DETERMINATION APPEALS PROCESS

1.) Has there been an initial decision in he matter? This can
be:

- * an existing published wage determination
- * a survey underlying a wage determination
- * a Wage and Hour Division letter setting forth a position on
a wage
determination matter
- * a conformance (additional classification and rate) ruling

On survey related matters, initial contact, including requests
for summaries
of surveys, should be with the Wage and Hour Regional Office
for the area in
which the survey was conducted because those Regional Offices
have
responsibility for the Davis-Bacon survey program. If the

response from this initial contact is not satisfactory, then the process described in 2.) and 3.) should be followed.

With regard to any other matter not yet ripe for the formal process described here, initial contact should be with the Branch of Construction Wage Determinations. Write to:

Branch of Construction Wage Determinations
Wage and Hour Division
U.S. Department of Labor
200 Constitution Avenue, N.W.
Washington, DC 20210

2.) If the answer to the question in 1.) is yes, then an interested party (those affected by the action) can request review and reconsideration from the Wage and Hour Administrator (See 29 CFR Part 1.8 and 29 CFR Part 7).
Write to:

Wage and Hour Administrator
U.S. Department of Labor
200 Constitution Avenue, N.W.
Washington, DC 20210

The request should be accompanied by a full statement of the interested party's position and by any information (wage payment data, project description, area practice material, etc.) that the requestor considers relevant to the issue.

3.) If the decision of the Administrator is not favorable, an interested party may appeal directly to the Administrative Review Board (formerly the Wage Appeals Board). Write to:

Administrative Review Board
U.S. Department of Labor
200 Constitution Avenue, N.W.
Washington, DC 20210

4.) All decisions by the Administrative Review Board are final.

END OF GENERAL DECISION

General Decision Number: MS100184 07/02/2010 MS184

Superseded General Decision Number: MS20080184

State: Mississippi

Construction Type: Highway

County: Holmes County in Mississippi.

HIGHWAY CONSTRUCTION PROJECTS (excluding tunnels, building structures in rest area projects & railroad construction; bascule, suspension & spandrel arch bridges designed for commercial navigation, bridges involving marine construction; and other major bridges).

Modification Number	Publication Date
0	03/12/2010
1	07/02/2010

* ELEC0480-007 07/01/2010

	Rates	Fringes
ELECTRICIAN.....	\$ 22.60	8.11

SUMS2008-102 09/04/2008		

	Rates	Fringes
CARPENTER, Including Form Work...	\$ 10.85	0.00
CEMENT MASON/CONCRETE FINISHER...	\$ 10.00	0.00
IRONWORKER, REINFORCING.....	\$ 9.67	0.00
LABORER: Common or General.....	\$ 8.35	0.00
LABORER: Pipelayer.....	\$ 9.96	0.00
LABORER: Asphalt Raker and Asphalt Shoveler.....	\$ 7.50	0.00
OPERATOR: Backhoe.....	\$ 11.43	0.00
OPERATOR: Broom.....	\$ 10.17	0.00
OPERATOR: Bulldozer.....	\$ 10.68	0.00
OPERATOR: Crane.....	\$ 14.92	0.00
OPERATOR: Grader/Blade.....	\$ 13.04	0.00
OPERATOR: Loader.....	\$ 9.00	0.00
OPERATOR: Mechanic.....	\$ 10.60	0.00
OPERATOR: Oiler.....	\$ 12.33	0.48
OPERATOR: Roller.....	\$ 9.75	0.00
OPERATOR: Scraper.....	\$ 11.15	0.00

OPERATOR: Tractor.....	\$ 10.05	0.00
OPERATOR: Asphalt Paver and Asphalt Spreader.....	\$ 10.00	0.00
TRUCK DRIVER.....	\$ 9.44	0.00

WELDERS - Receive rate prescribed for craft performing
operation to which welding is incidental.
=====

Unlisted classifications needed for work not included within
the scope of the
classifications listed may be added after award only as
provided in the labor
standards contract clauses (29 CFR 5.5(a)(1)(ii)).

--
In the listing above, the "SU" designation means that rates
listed under the
identifier do not reflect collectively bargained wage and
fringe benefit
rates. Other designations indicate unions whose rates have
been determined
to be prevailing.

--
WAGE DETERMINATION APPEALS PROCESS

1.) Has there been an initial decision in he matter? This can
be:

- * an existing published wage determination
- * a survey underlying a wage determination
- * a Wage and Hour Division letter setting forth a position on
a wage
determination matter
- * a conformance (additional classification and rate) ruling

On survey related matters, initial contact, including requests
for summaries
of surveys, should be with the Wage and Hour Regional Office
for the area in
which the survey was conducted because those Regional Offices
have
responsibility for the Davis-Bacon survey program. If the
response from this
initial contact is not satisfactory, then the process described
in 2.) and
3.) should be followed.

With regard to any other matter not yet ripe for the formal
process
described here, initial contact should be with the Branch of
Construction
Wage Determinations. Write to:

Branch of Construction Wage Determinations
Wage and Hour Division

U.S. Department of Labor
200 Constitution Avenue, N.W.
Washington, DC 20210

2.) If the answer to the question in 1.) is yes, then an interested party (those affected by the action) can request review and reconsideration from the Wage and Hour Administrator (See 29 CFR Part 1.8 and 29 CFR Part 7).

Write to:

Wage and Hour Administrator
U.S. Department of Labor
200 Constitution Avenue, N.W.
Washington, DC 20210

The request should be accompanied by a full statement of the interested party's position and by any information (wage payment data, project description, area practice material, etc.) that the requestor considers relevant to the issue.

3.) If the decision of the Administrator is not favorable, an interested party may appeal directly to the Administrative Review Board (formerly the Wage Appeals Board). Write to:

Administrative Review Board
U.S. Department of Labor
200 Constitution Avenue, N.W.
Washington, DC 20210

4.) All decisions by the Administrative Review Board are final.

END OF GENERAL DECISION

General Decision Number: MS100206 07/02/2010 MS206

Superseded General Decision Number: MS20080206

State: Mississippi

Construction Type: Highway

Counties: Claiborne, Jefferson and Pike Counties in Mississippi.

HIGHWAY CONSTRUCTION PROJECTS (excluding tunnels, building structures in rest area projects & railroad construction; bascule, suspension & spandrel arch bridges designed for commercial navigation, bridges involving marine construction; and other major bridges).

Modification Number	Publication Date
0	03/12/2010
1	07/02/2010

* ELEC0480-007 07/01/2010

	Rates	Fringes
ELECTRICIAN.....	\$ 22.60	8.11

SUMS2008-124 09/04/2008

	Rates	Fringes
CARPENTER, Including Form Work...	\$ 11.42	0.12
CEMENT MASON/CONCRETE FINISHER...	\$ 10.82	0.00
IRONWORKER, REINFORCING.....	\$ 11.30	0.00
LABORER: Common or General.....	\$ 8.64	0.00
LABORER: Pipelayer.....	\$ 9.68	0.00
OPERATOR: Backhoe.....	\$ 11.32	0.00
OPERATOR: Broom.....	\$ 10.17	0.00
OPERATOR: Bulldozer.....	\$ 10.77	0.00
OPERATOR: Crane.....	\$ 14.57	0.00
OPERATOR: Grader/Blade.....	\$ 12.46	0.00
OPERATOR: Loader.....	\$ 10.15	0.00
OPERATOR: Mechanic.....	\$ 12.04	0.00
OPERATOR: Oiler.....	\$ 12.33	0.48
OPERATOR: Roller.....	\$ 9.31	0.00
OPERATOR: Scraper.....	\$ 10.00	0.00
OPERATOR: Tractor.....	\$ 7.79	0.00

OPERATOR: Asphalt Paver and
 Asphalt Spreader.....\$ 10.00 0.00

TRUCK DRIVER.....\$ 9.22 0.00

WELDERS - Receive rate prescribed for craft performing
 operation to which welding is incidental.

=====

Unlisted classifications needed for work not included within
 the scope of the
 classifications listed may be added after award only as
 provided in the labor
 standards contract clauses (29 CFR 5.5(a)(1)(ii)).

--

In the listing above, the "SU" designation means that rates
 listed under the
 identifier do not reflect collectively bargained wage and
 fringe benefit
 rates. Other designations indicate unions whose rates have
 been determined
 to be prevailing.

WAGE DETERMINATION APPEALS PROCESS

1.) Has there been an initial decision in he matter? This can
 be:

- * an existing published wage determination
- * a survey underlying a wage determination
- * a Wage and Hour Division letter setting forth a position on
 a wage
 determination matter
- * a conformance (additional classification and rate) ruling

On survey related matters, initial contact, including requests
 for summaries
 of surveys, should be with the Wage and Hour Regional Office
 for the area in
 which the survey was conducted because those Regional Offices
 have
 responsibility for the Davis-Bacon survey program. If the
 response from this
 initial contact is not satisfactory, then the process described
 in 2.) and
 3.) should be followed.

With regard to any other matter not yet ripe for the formal
 process
 described here, initial contact should be with the Branch of
 Construction
 Wage Determinations. Write to:

Branch of Construction Wage Determinations
 Wage and Hour Division
 U.S. Department of Labor

200 Constitution Avenue, N.W.
Washington, DC 20210

2.) If the answer to the question in 1.) is yes, then an interested party (those affected by the action) can request review and reconsideration from the Wage and Hour Administrator (See 29 CFR Part 1.8 and 29 CFR Part 7).
Write to:

Wage and Hour Administrator
U.S. Department of Labor
200 Constitution Avenue, N.W.
Washington, DC 20210

The request should be accompanied by a full statement of the interested party's position and by any information (wage payment data, project description, area practice material, etc.) that the requestor considers relevant to the issue.

3.) If the decision of the Administrator is not favorable, an interested party may appeal directly to the Administrative Review Board (formerly the Wage Appeals Board). Write to:

Administrative Review Board
U.S. Department of Labor
200 Constitution Avenue, N.W.
Washington, DC 20210

4.) All decisions by the Administrative Review Board are final.

END OF GENERAL DECISION

Guardrail installation on various routes throughout the District, known as Federal Aid Project No. MDPS-0000-03(004) / 105962303, in District (3), State of Mississippi.

I (We) agree to complete the entire project within the specified contract time.

***** SPECIAL NOTICE TO BIDDERS *****

**BIDS WILL NOT BE CONSIDERED UNLESS BOTH UNIT PRICES AND ITEM TOTALS ARE ENTERED.
 BIDS WILL NOT BE CONSIDERED UNLESS THE BID CERTIFICATION LOCATED AT THE END OF THE BID SHEETS IS SIGNED**

*****BID SCHEDULE*****

Line No.	Item Code	Adj Code	Quantity	Units	Description	Unit Price		Item Amount	
						Dollar	Ct	Dollar	Ct
Roadway Items									
0010	202-B087		2,700	Linear Feet	Removal of Guard Rail, Including Rails, Posts and Terminal Ends				
0020	203-EX017	(E)	15,050	Cubic Yard	Borrow Excavation, AH, FME, Class B9				
0030	212-B001		82,280	Square Yard	Standard Ground Preparation				
0040	213-B001		9	Ton	Combination Fertilizer, 13-13-13				
0050	216-A001		82,280	Square Yard	Solid Sodding				
0060	219-A001		1,646	Thousand Gallon	Watering	20.	00	32,920.	00
0070	234-A001		5,400	Linear Feet	Temporary Silt Fence				
0080	606-B001		3,600	Linear Feet	Guard Rail, Class A, Type 1				

Line No.	Item Code	Adj Code	Quantity	Units	Description	Unit Price		Bid Amount	
0090	606-D008 Deleted 08/16/2010					XXXXXXXX	XXX	XXXXXXXX	XXX
0091	606-D001 Added 08/16/2010		12	Each	Guard Rail, Bridge End Section, Type A				
0092	606-D003 Added 08/16/2010		12	Each	Guard Rail, Bridge End Section, Type D Modified				
0093	606-D007 Added 08/16/2010		8	Each	Guard Rail, Bridge End Section, Type G, Modified				
0094	606-D011 Added 08/16/2010		4	Each	Guard Rail, Bridge End Section, Type A Modified				
0100	606-E003		36	Each	Guard Rail, Terminal End Section, Non-Flared				
0105	606-F001 Added 08/16/2010		12	Each	Special Sections, Bridge Connector				
0110	618-A001		1	Lump Sum	Maintenance of Traffic	XXXXXXXX	XXX		
0120	620-A001		1	Lump Sum	Mobilization	XXXXXXXX	XXX		
0130	630-F001		168	Each	Delineators, Guard Rail, White				
0140	630-G002		36	Each	Type 3 Object Markers, OM-3R or OM-3L, Post Mounted				
0150	907-213-A001		34	Ton	Agricultural Limestone				

Section 905
Proposal (Sheet 2 - 3)

MDPS-0000-03(004) / 105962303
District 3

Line No.	Item Code	Adj Code	Quantity	Units	Description	Unit Price		Bid Amount	
0160	907-237-A003		2,160	Linear Feet	Wattles, 20"				

*** BID CERTIFICATION ***

TOTAL BID.....\$_____

*** DBE/WBE SECTION ***

Complete item nos. 1, 2, and/or 3 as appropriate. See Notice to Bidders addressing Disadvantaged Business Enterprises in Highway Construction.

1. I/We agree that no less than _____ percent shall be expended with small business concerns owned and controlled by socially and economically disadvantaged individuals (DBE and WBE).
2. Classification of Bidder: Small Business (DBE)_____ Small Business (WBE)_____
3. A joint venture with a Small Business (DBE/WBE): _____

*** SIGNATURE STATEMENT ***

BIDDER ACKNOWLEDGES THAT HE/SHE HAS CHECKED ALL ITEMS IN THIS PROPOSAL FOR ACCURACY AND CERTIFIED THAT THE FIGURES SHOWN THEREIN CONSTITUTE THEIR OFFICIAL BID.

BIDDER'S SIGNATURE

BIDDER'S COMPANY

BIDDER'S FEDERAL TAX ID NUMBER