

SECTION 905 -- PROPOSAL (CONTINUED)

I (We) further propose to execute the attached contract agreement (Section 902) as soon as the work is awarded to me (us), and to begin and complete the work within the time limit(s) provided for in the Specifications and Advertisement. I (We) also propose to execute the attached contract bond (Section 903) in an amount not less than one hundred (100) percent of the total of my (our) part, but also to guarantee the excellence of both workmanship and materials until the work is finally accepted.

I (We) enclose a certified check, cashier's check or bid bond for **five percent (5%) of total bid** and hereby agree that in case of my (our) failure to execute the contract and furnish bond within Ten (10) days after notice of award, the amount of this check (bid bond) will be forfeited to the State of Mississippi as liquidated damages arising out of my (our) failure to execute the contract as proposed. It is understood that in case I am (we are) not awarded the work, the check will be returned as provided in the Specifications.

Bidder acknowledges receipt of and has added to and made a part of the proposal and contract documents the following addendum (addenda):

ADDENDUM NO. 1 DATED 9/2/2014 ADDENDUM NO. DATED
 ADDENDUM NO. 2 DATED 09/18/2014 ADDENDUM NO. DATED

Number	Description
1	Revised NTB No. 5163; Revised BidItems; Revised or Added Plan Sheet Nos. 2, 5, 8, 9, & 26; Amendment EBS Download Required.
2	Revised BidItems; Revised or Added Plan Sheet Nos. 2, 9, 10, 11, 13, 61, 62, 63, 64, & 65; Amendment EBS Download Required.

TOTAL ADDENDA: 2
 (Must agree with total addenda issued prior to opening of bids)

Respectfully Submitted,

DATE _____

 Contractor

BY _____
 Signature

TITLE _____

ADDRESS _____

CITY, STATE, ZIP _____

PHONE _____

FAX _____

E-MAIL _____

(To be filled in if a corporation)

Our corporation is chartered under the Laws of the State of _____ and the names, titles and business addresses of the executives are as follows:

_____ President	_____ Address
_____ Secretary	_____ Address
_____ Treasurer	_____ Address

The following is my (our) itemized proposal.

Revised 09/21/2005

NHPP-0009-01(129) / 106653301

Wilkinson County(ies)

Slide Repair on US 61 at Cold Spring Road Intersection, known as Federal Aid Project No. NHPP-0009-01(129) / 106653301 in Wilkinson County.

Line No.	Item Code	Adj Code	Quantity	Units	Description [Fixed Unit Price]
Roadway Items					
0010	201-A001		1	Lump Sum	Clearing and Grubbing
Changed 09/02/2014					
0020	202-B005		3,207	Square Yard	Removal of Asphalt Pavement, All Depths
Changed 09/02/2014					
0030	202-B057		1	Each	Removal of Inlets, All Sizes
0040	202-B138		125	Square Yard	Removal of Riprap
0050	202-B153		143	Each	Removal of Steel Piling
0060	203-EX035	(E)	71,432	Cubic Yard	Borrow Excavation, AH, FME, Class B9-6
Changed 09/18/2014					
0070	203-F001	(E)	8,850	Cubic Yard	Channel Excavation, FM
0080	203-G004	(E)	9,564	Cubic Yard	Excess Excavation, LVM, AH
Changed 09/02/2014					
0090	204-A003		3,638	Square Yard	Geogrid, Type II, Biaxial
0100	211-B001	(E)	9,547	Cubic Yard	Topsoil for Slope Treatment, Contractor Furnished
0110	213-C001		6	Ton	Superphosphate
0120	219-A001		92	Thousand Gallon	Watering [\$20.00]
0130	220-A001		12	Acre	Insect Pest Control [\$30.00]
0140	223-A001		12	Acre	Mowing [\$50.00]
0150	234-A001		2,400	Linear Feet	Temporary Silt Fence
Changed 09/02/2014					
0160	235-A001		325	Bale	Temporary Erosion Checks
0170	309-A002		850	Cubic Yard	Crushed Stone Drainage Layer
0180	423-A001		1	Mile	Rumble Strips, Ground In
0185	406-A001		1,133	Square Yard	Cold Milling of Bituminous Pavement, All Depths
Added 09/18/2014					
0190	503-C007		154	Linear Feet	Saw Cut, Full Depth
0200	907-603-ALT02	(S)	48	Linear Feet	24" Type A Alternate Pipe
Changed 09/02/2014					
0210	605-AA005	(S)	11,608	Square Yard	Geotextile for Subsurface Drainage, Type V, Non-Woven
0220	605-W002	(GY)	600	Cubic Yard	Filter Material for Combination Storm Drain and/or Underdrains, Type B, FM
0230	619-A1001		971	Linear Feet	Temporary Traffic Stripe, Continuous White
0235	619-A1007		4,895	Linear Feet	Temporary Traffic Stripe, Continuous White, Type 1 Tape
Changed 09/18/2014					

Line No.	Item Code	Adj Code	Quantity	Units	Description [Fixed Unit Price]
0240	619-A2001		591	Linear Feet	Temporary Traffic Stripe, Continuous Yellow
0245	619-A2007 Changed 09/18/2014		10,598	Linear Feet	Temporary Traffic Stripe, Continuous Yellow, Type 1 Tape
0250	619-A3001 Changed 09/02/2014		1,000	Linear Feet	Temporary Traffic Stripe, Skip White
0260	619-A5001 Changed 09/02/2014		1,108	Linear Feet	Temporary Traffic Stripe, Detail
0261	619-A5004 Changed 09/18/2014		2,449	Linear Feet	Temporary Traffic Stripe, Detail, Type 1 Tape
0262	619-A6001 Added 09/02/2014		255	Linear Feet	Temporary Traffic Stripe, Legend
0270	619-D1001 Changed 09/18/2014		175	Square Feet	Standard Roadside Construction Signs, Less than 10 Square Feet
0280	619-D2001 Changed 09/18/2014		606	Square Feet	Standard Roadside Construction Signs, 10 Square Feet or More
0281	619-E1001 Added 09/02/2014		2	Each	Flashing Arrow Panel, Type C
0283	619-F5001 Added 09/02/2014		249	Unit	Snap-Back Delineator, Replacement
0284	619-G4005 Added 09/02/2014		48	Linear Feet	Barricades, Type III, Double Faced
0285	619-G7001 Changed 09/18/2014		15	Each	Warning Lights, Type "B"
0290	619-F4001		83	Unit	Snap-Back Delineator
0300	619-G4001 Changed 09/02/2014		168	Linear Feet	Barricades, Type III, Single Faced
0310	619-G5001 Changed 09/02/2014		109	Each	Free Standing Plastic Drums
0320	620-A001		1	Lump Sum	Mobilization
0330	627-K001 Changed 09/02/2014		43	Each	Red-Clear Reflective High Performance Raised Markers
0335	627-L001 Added 09/02/2014		15	Each	Two-Way Yellow Reflective High Performance Raised Markers
0340	815-A006	(S)	3,890	Ton	Loose Riprap, Size 100
0350	815-A008	(S)	550	Ton	Loose Riprap, Size 200

Line No.	Item Code	Adj Code	Quantity	Units	Description [Fixed Unit Price]
0360	815-A009	(S)	3,810	Ton	Loose Riprap, Size 300
	Changed 09/02/2014				
0370	815-A010	(S)	275	Ton	Loose Riprap, Size 500
0380	907-216-A001		4,600	Square Yard	Solid Sodding
0385	907-619-E3001		2	Each	Changeable Message Sign
	Added 09/02/2014				
0390	907-225-A001		12	Acre	Grassing
0400	907-225-B001		6	Ton	Agricultural Limestone
	Changed 09/18/2014				
0410	907-225-C001		12	Ton	Mulch, Vegetative Mulch
	Changed 09/02/2014				
0420	907-225-D001		12	Ton	Mulch, Hydromulch
	Changed 09/02/2014				
0430	907-226-A001		12	Acre	Temporary Grassing
0440	907-237-A003		1,630	Linear Feet	Wattles, 20"
0450	907-245-A001		240	Linear Feet	Triangular Silt Dike
0460	907-246-A001		950	Linear Feet	Sandbags
0470	907-304-A004	(GY)	407	Cubic Yard	Granular Material, LVM, Class 6, Group C
0480	907-304-E004	(GY)	1,200	Cubic Yard	Granular Material, LVM, Size 57
0490	907-304-F004	(GT)	800	Ton	Size 825B Crushed Stone Base
0500	907-407-A001	(A2)	293	Gallon	Asphalt for Tack Coat
0510	907-603-PE208	(S)	780	Linear Feet	36" Corrugated Polyethylene Pipe
0520	907-603-PE211	(S)	100	Linear Feet	12" Corrugated Polyethylene Pipe
0530	907-605-Q002	(S)	1,145	Linear Feet	6" Perforated Corrugated Polyethylene Drainage Tubing for Underdrains
0540	907-617-A001		4	Each	Right-of-Way Marker
	Changed 09/18/2014				
0550	907-618-A001		1	Lump Sum	Maintenance of Traffic
0560	907-618-B001				Deleted 09/18/2014
0570	907-626-A004		1,000	Linear Feet	6" Thermoplastic Traffic Stripe, Skip White
0580	907-626-C008		971	Linear Feet	6" Thermoplastic Edge Stripe, Continuous White
0590	907-626-F008		591	Linear Feet	6" Thermoplastic Edge Stripe, Continuous Yellow
0600	907-626-G004		809	Linear Feet	Thermoplastic Detail Stripe, White
	Changed 09/02/2014				
0610	907-626-G005		2,525	Linear Feet	Thermoplastic Detail Stripe, Yellow
	Changed 09/02/2014				

Line No.	Item Code	Adj Code	Quantity	Units	Description [Fixed Unit Price]
0615	907-626-H004		510	Linear Feet	Thermoplastic Legend, White Added 09/02/2014
0620	907-699-A002		1	Lump Sum	Roadway Construction Stakes ALTERNATE GROUP AA NUMBER 1
0630	907-304-G001	(GY)	1,549	Cubic Yard	Size 825B Crushed Stone Base, AEA ALTERNATE GROUP AA NUMBER 2
0640	907-304-G002	(GY)	1,549	Cubic Yard	Size 610 Crushed Stone Base, AEA ALTERNATE GROUP AA NUMBER 3
0650	907-304-G003	(GY)	1,549	Cubic Yard	Size 3/4" and Down Crushed Stone Base, AEA ALTERNATE GROUP BB NUMBER 1
0660	907-403-A006	(BA1)	324	Ton	Hot Mix Asphalt, MT, 12.5-mm mixture ALTERNATE GROUP BB NUMBER 2
0670	907-403-M002	(BA1)	324	Ton	Warm Mix Asphalt, MT, 12.5-mm mixture ALTERNATE GROUP CC NUMBER 1
0680	907-403-A007	(BA1)	389	Ton	Hot Mix Asphalt, MT, 19-mm mixture ALTERNATE GROUP CC NUMBER 2
0690	907-403-M007	(BA1)	389	Ton	Warm Mix Asphalt, MT, 19-mm mixture ALTERNATE GROUP DD NUMBER 1
0700	907-403-A012	(BA1)	389	Ton	Hot Mix Asphalt, ST, 19-mm mixture ALTERNATE GROUP DD NUMBER 2
0710	907-403-M004	(BA1)	389	Ton	Warm Mix Asphalt, ST, 19-mm mixture ALTERNATE GROUP EE NUMBER 1
0720	907-403-A010	(BA1)	289	Ton	Hot Mix Asphalt, MT, 9.5-mm mixture ALTERNATE GROUP EE NUMBER 2
0730	907-403-M006	(BA1)	289	Ton	Warm Mix Asphalt, MT, 9.5-mm mixture

ADDENDUM

STATE	PROJECT NO.
MISS.	NHPP-0009-01(129)

DESCRIPTION OF SHEET	WKG. NO.	SH. NO.	DESCRIPTION OF SHEET	WKG. NO.	SH. NO.
TITLE SHEET (1)		1	SPECIAL DESIGN SHEETS (CONT.)		
DETAILED INDEX & GENERAL NOTES (2)			LOCATION OF R16-3 SIGNS	R16-3	51
			RIGHT OF WAY MARKER	RW-1	52
			RIGHT OF WAY COORDINATE SHEET	RW-2	53
DETAILED INDEX	DI-1	2	HIGHWAY SIGNS AND BARRICADE DETAIL FOR CONSTRUCTION PROJECT	SDTCP-10	54
GENERAL NOTES	GN-1	3	TRAFFIC CONTROL DETAIL OF DRUM PLACEMENT AND SHOULDER	TCP-SC	55
			RUMBLE STRIPES (GROUND IN) 2 LANE	RS-2L	56
TYPICAL SECTION SHEETS (4)			SUPERELEVATION CASE I ROTATION ABOUT CENTERLINE (2% NORMAL SUBGRADE)	SDSE-2A	57
▲ TYPICAL SECTION - EXISTING U.S. HWY. 61	TS-1	4	SUPERELEVATION RUNOFF CASE I ROTATION ABOUT CENTERLINE	SDRO-1	58
TYPICAL SECTION - OVERLAY SECTION (RT. LANE)	TS-2	5	DETAILS OF MEDIAN CROSSOVER	DMC-1	59
TYPICAL SECTION - NEW CONSTRUCTION (RT. LANE)	TS-3	6			
TYPICAL SECTION - @ CROSSOVER	TS-4	7	TRAFFIC CONTROL - (PHASE I)	TC-3	60
			TRAFFIC CONTROL - (PHASE I)	TC-4	61
			TRAFFIC CONTROL - (PHASE I)	TC-5	62
			TRAFFIC CONTROL - (PHASE I)	TC-6	63
			TRAFFIC CONTROL - (PHASE I)	TC-7	64
			TRAFFIC CONTROL - (PHASE I)	TC-8	65
QUANTITY SHEETS (6)			TRAFFIC CONTROL - (PHASE I)	TC-9	66
SUMMARY OF QUANTITIES	SQ-1	8	TRAFFIC CONTROL - (PHASE II) PERMANENT STRIPING	TC-10	67
SUMMARY OF QUANTITIES	SQ-2	9			
SUMMARY OF QUANTITIES	SQ-3	10			
			▲ PRELIMINARY EROSION CONTROL PLAN (STA. 680+00 TO STA. 709+00)	ECP-3	68
SUMMARY OF TRAFFIC CONTROL ITEMS	SQ-4	11	▲ PRELIMINARY EROSION CONTROL PLAN (PHASE I TYPICAL SECTION)	ECP-4	69
ESTIMATED QUANTITIES - EARTHWORK	EQ-1	12	▲ PRELIMINARY EROSION CONTROL PLAN (PHASE II TYPICAL SECTION)	ECP-5	70
ESTIMATED QUANTITIES FOR TRAFFIC CONTROL SIGNS	EQ-2	13	▲ PRELIMINARY EROSION CONTROL PLAN (PLAN- LANDSLIDE REMEDIATION)	ECP-6	71
			▲ STANDARD DRAWINGS - ROADWAY SHEETS (13)		
PLAN & PROFILE SHEET (1)					
STA. 680+00 TO STA. 710+00					
SPECIAL DESIGN SHEETS (58)	3	14	PAVEMENT MARKING DETAILS FOR 2-LANE & 4-LANE DIVIDED HIGHWAYS	12/01/99	PM-1 6120
			EROSION CONTROL		EC-1 6140
SEQUENCE OF CONSTRUCTION STA. NO. : 693+75 TO 701+00	SC-1	15	TYPICAL TEMPORARY EROSION CONTROL MEASURES	TEC-3	6144
PHASE 1 - TYPICAL SECTIONS STA. NO. : 693+50 TO 701+50	SC-2	16	TYPICAL CROSSOVER DELINEATION	SN-8B	6235
PHASE 2 - TYPICAL SECTIONS STA. NO. : 693+50 TO 701+50	SC-3	17			
PLAN - LANDSLIDE REMEDIATION STA. NO. : 693+50 TO 701+50	SC-4	18			
PHASE 1 - PLAN (SHEET 1 OF 2) STA. NO. : 693+50 TO 701+50	SC-5	19	TRAFFIC CONTROL PLAN WITH FLAGGER (ONE-LANE CLOSURE OF TWO WAY TRAFFIC)	TCP-1	6250
PHASE 1 - PLAN (SHEET 2 OF 2) STA. NO. : 693+50 TO 701+50	SC-6	20			
PHASE 2 - PLAN (SHEET 1 OF 2) STA. NO. : 693+50 TO 701+50	SC-7	21	SHORT DURATION CLOSING OF DIVIDED HIGHWAYS	TCP-9	6258
PHASE 2 - PLAN (SHEET 2 OF 2) STA. NO. : 693+50 TO 701+50	SC-8	22	TRAFFIC CONTROL PLAN MOBILE OPERATIONS MULTILANE ROADS AND TWO-LANE		
DETAILS - (SHEET 1 OF 2) STA. NO. : 693+50 TO 701+50	SC-9	23	ROADS	12/01/99	TCP-11 6260
DETAILS - (SHEET 2 OF 2) STA. NO. : 693+50 TO 701+50	SC-10	24			
GENERALIZED SOIL PROFILE STA. NO. : 693+50 TO 701+50	SC-11	25	TEMPORARY STRIPING FOR TRAFFIC CONTROL 2-LANE AND 4-LANE	12/01/99	TCP-15 6264
GENERALIZED SOIL PROFILE STA. NO. : 693+50 TO 701+50	SC-12	25.1	TYPICAL GRADING TRANSITION BETWEEN CUTS AND FILL	GT-1	6272
▲ GENERALIZED SOIL PROFILE STA. NO. : 693+50 TO 701+50	SC-13	25.2	MISCELLANEOUS DETAIL SHEET	MDS-1	6290
			PIPE CULVERT INSTALLATION	PI-1	6300
VEGETATION SCHEDULE	VS-1	26			
▲ DETAILS OF TYPICAL DITCH TREATMENT	DT-1	27	DETAILS OF NORMAL UNDERDRAIN AND STORM DRAIN USED AS UNDERDRAIN	UD-1	6331
▲ DELETED SHEET 28			NORMAL UNDERDRAIN TYPE II	UD-2	6332
TYPICAL TEMPORARY EROSION SEDIMENT CONTROL APPLICATIONS	ECD-1	29	X-SECTION (76)		
DETAILS OF SEDIMENT BARRIER APPLICATIONS	ECD-2	30			
DETAILS OF SILT FENCE INSTALLATION	ECD-3	31	STA. 690+00 TO STA. 705+00		9001-9076
DITCH CHECK STRUCTURES, TYPICAL APPLICATIONS AND DETAILS	ECD-4	32			
TEMPORARY EROSION, SILT FENCE AND HAY BALE DITCH CHECKS	ECD-5	33	▲ TOTAL SHEETS (161)		
DETAILS OF EROSION CONTROL WATTLE DITCH CHECKS	ECD-6	34			
DETAILS OF EROSION CONTROL SILT DIKE DITCH CHECK	ECD-7	35			
ROCK DITCH CHECK	ECD-8	36			
ROCK DITCH CHECK WITH SUMP EXCAVATION	ECD-9	37			
INLET PROTECTION TYPICAL APPLICATIONS AND DETAILS	ECD-10	38			
INLET PROTECTION DETAILS FOR COURSE AGGREGATE ON GRADES & SAGS	ECD-11	39			
INLET PROTECTION DETAILS OF WATTLES	ECD-12	40			
INLET PROTECTION DETAILS OF MANUFACTURED INLET PROTECTION DEVICE	ECD-13	41			
INLET PROTECTION DETAILS OF SAND BAG	ECD-14	42			
STABILIZED CONSTRUCTION ENTRANCE	ECD-15	43			
TEMPORARY CULVERT STREAM CROSSING	ECD-16	44			
TEMPORARY STREAM DIVERSION	ECD-17	45			
TEMPORARY STREAM DIVERSION (BOX EXTENSIONS)	ECD-18	46			
FLOATING TURBIDITY CURTAIN	ECD-19	47			
DETAILS OF EROSION CONTROL SANDBAG DITCH CHECK	ECD-20	48			
TYPICAL TEMPORARY EROSION CONTROL MEASURES	TEC-2	49			
TYPICAL TEMPORARY EROSION CONTROL MEASURES (TYPE B SILT BASIN)	TEC-3	50			

ROBERTS (106653/301000)

PS & E PLANS - DATE (07/28/2014)		
REVISIONS		
DATE	SHEET NO.	BY
8/1/2014	1-19,21-25, 25.1,25.2	BJR
	26,28,53,54,59-71	
8/28/2014	2,5,8,9,26	BJR
9/08/2014	9-11,13,61-65	BJR

REVISIONS DATE BY DESCRIPTION	MISSISSIPPI DEPARTMENT OF TRANSPORTATION DETAIL INDEX
	WILKINSON COUNTY PROJECT NO.: NHPP-0009-01(129) FILENAME: DETINDEX.DGN DESIGN TEAM: ROBERTS CHECKED: DATE:



WORKING NUMBER
DI-1
SHEET NUMBER
2

9/5/2014 2:44 PM DETINDEX.DGN

ADDENDUM

STATE	PROJECT NO.
MISS.	NHPP-0009-01(129)

SUMMARY OF QUANTITIES (SHEET 2)

PAY ITEM NO.	PAY ITEM	UNIT	PRELIMINARY	FINAL
CRUSHED STONE ALTERNATES				
907-304-G001	SIZE 825B CRUSHED STONE BASE, AEA	CY	1,549	
OR	OR			
907-304-G002	SIZE 610 CRUSHED STONE BASE, AEA	CY	1,549	
OR	OR			
907-304-G003	SIZE 3/4" AND DOWN CRUSHED STONE BASE, AEA	CY	1,549	
309-A002	CRUSHED STONE DRAINAGE LAYER	CY	850	
ALTERNATE ASPHALT ITEMS				
907-403-A006	HOT MIX ASPHALT, MT, 12.5-MM MIXTURE	TON	324	
OR	OR			
907-403-M002	WARM MIX ASPHALT, MT, 12.5-MM MIXTURE	TON	324	
907-403-A007	HOT MIX ASPHALT, MT, 19-MM MIXTURE	TON	389	
OR	OR			
907-403-M007	WARM MIX ASPHALT, MT, 19-MM MIXTURE	TON	389	
907-403-A012	HOT MIX ASPHALT, ST, 19-MM MIXTURE	TON	389	
OR	OR			
907-403-M004	WARM MIX ASPHALT, ST, 19-MM MIXTURE	TON	389	
907-403-A010	HOT MIX ASPHALT, MT, 9.5-MM MIXTURE	TON	289	
OR	OR			
907-403-M006	WARM MIX ASPHALT, MT, 9.5-MM MIXTURE	TON	289	
406-A001	COLD MILLING OF BITUMINOUS PAVEMENT, ALL DEPTHS	SY	1,133	
907-407-A001	ASPHALT FOR TACK COAT	GAL	293	
423-A001	RUMBLE STRIPS, GROUND IN	MI	1	
503-C007	SAW CUT, FULL DEPTH	LF	154	
907-603-ALT02	24" TYPE A ALTERNATE PIPE	LF	48	
907-603-PE208	36" CORRUGATED POLYETHYLENE PIPE , PERFORATED	LF	780	
907-603-PE211	12" CORRUGATED POLYETHYLENE PIPE , PERFORATED	LF	100	
605-AA005	GEOTEXTILE FOR SUBSURFACE DRAINAGE, TYPE V, NON-WOVEN	SY	11,608	
907-605-Q002	6" PERFORATED CORRUGATED POLYETHYLENE DRAINAGE TUBING FOR UNDERDRAINS	LF	1,145	
605-W002	FILTER MATERIAL FOR COMBINATION STORM DRAIN AND/OR UNDERDRAINS,TYPE B, FM	CY	600	
907-617-A001	RIGHT-OF-WAY MARKER	EA	4	
907-618-A001	MAINTENANCE OF TRAFFIC	LS	100%	
619-A1001	TEMPORARY TRAFFIC STRIPE, CONTINUOUS WHITE	LF	971	
619-A1007	TEMPORARY TRAFFIC STRIPE, CONTINUOUS WHITE, TYPE 1 TAPE	LF	4,895	
619-A2001	TEMPORARY TRAFFIC STRIPE, CONTINUOUS YELLOW	LF	591	
619-A2007	TEMPORARY TRAFFIC STRIPE, CONTINUOUS YELLOW, TYPE 1 TAPE	LF	10,598	
619-A3001	TEMPORARY TRAFFIC STRIPE, SKIP WHITE	LF	1,000	
619-A5001	TEMPORARY TRAFFIC STRIPE, DETAIL	LF	1,108	
619-A5004	TEMPORARY TRAFFIC STRIPE, DETAIL, TYPE 1 TAPE	LF	2,449	
619-A6001	TEMPORARY TRAFFIC STRIPE, LEGEND	LF	255	

- ① INCLUDES 5,888 SQ. YD'S FOR NEW CONSTRUCTION TYPICAL AND 5,720 SQ. YD'S FOR LANDSLIDE REPAIR.
- ② SEE SHEET TS-3 FOR DETAILS. ⚠
- ③ SEE SHEET SC-10 FOR DETAILS. ⚠
- ④ ALTERNATE A ⚠ REINFORCED CONCRETE PIPE, CLASS "III" OR CORRUGATED POLYETHYLENE PIPE OR POLYVINYL CHLORIDE (PVC) PIPE.
- ⑤ SEE SHEET SC-9 FOR DETAILS. ⚠
- ⑥ PIPE ASSEMBLY INCLUDES GEOTEXTILE ⚠ SOCK, JOINT CONNECTIONS, END CAPS AND ANIMAL GUARD.

9/8/2014 2:04 PM SQS.SH.DGN

BY	DATE	REVISION	MISSISSIPPI DEPARTMENT OF TRANSPORTATION SUMMARY OF QUANTITIES WILKINSON COUNTY PROJECT NO.: NHPP-0009-01(129) FILENAME: SQS.SH.DGN DESIGN TEAM: ROBERTS CHECKED: DATE:
REVISED QUANTITIES			
ADDED PAY ITEM			



WORKING NUMBER
SQS-2
 SHEET NUMBER
9

ADDENDUM

STATE	PROJECT NO.
MISS.	NHPP-0009-01(129)

SUMMARY OF QUANTITIES (SHEET 3)

PAY ITEM NO.	PAY ITEM	UNIT	PRELIMINARY	FINAL
619-D1001	STANDARD ROADSIDE CONSTRUCTION SIGNS, LESS THAN 10 SQUARE FEET	SF	175	
619-D2001	STANDARD ROADSIDE CONSTRUCTION SIGNS, 10 SQUARE FEET OR MORE	SF	606	
619-E1001	FLASHING ARROW PANEL, TYPE C	EA	2	
907-619-E3001	CHANGEABLE MESSAGE SIGN	EA	2	
619-F4001	SNAP-BACK DELINEATOR	UNIT	83	
619-F5001	SNAP-BACK DELINEATOR, REPLACEMENT	UNIT	249	
619-G4001	BARRICADES, TYPE III, SINGLE FACED	LF	168	
619-G4005	BARRICADES, TYPE III, DOUBLE FACED	LF	48	
619-G5001	FREE STANDING PLASTIC DRUMS	EA	109	
619-G7001	WARNING LIGHTS, TYPE "B"	EA	15	
620-A001	MOBILIZATION	LS	100%	
907-626-A004	6" THERMOPLASTIC TRAFFIC STRIPE, SKIP WHITE	LF	1,000	
907-626-C008	6" THERMOPLASTIC EDGE STRIPE, CONTINUOUS WHITE	LF	971	
907-626-F008	6" THERMOPLASTIC EDGE STRIPE, CONTINUOUS YELLOW	LF	591	
907-626-G004	THERMOPLASTIC DETAIL STRIPE, WHITE	LF	809	
907-626-G005	THERMOPLASTIC DETAIL STRIPE, YELLOW	LF	2,525	
907-626-H004	THERMOPLASTIC LEGEND, WHITE	LF	510	
627-K001	RED-CLEAR REFLECTIVE HIGH PERFORMANCE RAISED MARKERS	EA	43	
627-L001	TWO-WAY YELLOW REFLECTIVE HIGH PERFORMANCE RAISED MARKERS	EA	15	
907-699-A002	ROADWAY CONSTRUCTION STAKES	LS	100%	
815-A006	LOOSE RIPRAP, SIZE 100	TON	3,890	
815-A008	LOOSE RIPRAP, SIZE 200	TON	550	
815-A009	LOOSE RIPRAP, SIZE 300	TON	3,810	
815-A010	LOOSE RIPRAP, SIZE 500	TON	275	

① PHASE I TRAFFIC CONTROL (IN PLACE) - QUANTITIES ESTIMATED FOR FULL REPLACEMENT OF PHASE I TRAFFIC CONTROL DEVICES, DAMAGED OR LOST DURING CONSTRUCTION.

② INCLUDES 1,000 TONS TO BE USED AS DIRECTED BY THE ENGINEER. ⚠

9/8/2014 2:04 PM SDS-SH-DDN

02/08/14	REVISOR	08/11/14	REVISOR	08/11/14	REVISOR	08/11/14	REVISOR	08/11/14	REVISOR
	REVISED QUANTITIES		REVISED QUANTITIES		REVISED QUANTITIES		REVISED QUANTITIES		REVISED QUANTITIES
	BY		BY		BY		BY		BY

MISSISSIPPI DEPARTMENT OF TRANSPORTATION
SUMMARY OF QUANTITIES

WILKINSON COUNTY
 PROJECT NO.: NHPP-0009-01(129)

FILENAME: _____
 DESIGN TEAM: ROBERTS CHECKED: _____ DATE: _____

WORKING NUMBER: SQS-3
 SHEET NUMBER: 10



ADDENDUM

STATE	PROJECT NO.
MISS.	NHPP-0009-01(129)

ROADWAY PLAN DIVISION
MISSISSIPPI DEPARTMENT OF TRANSPORTATION

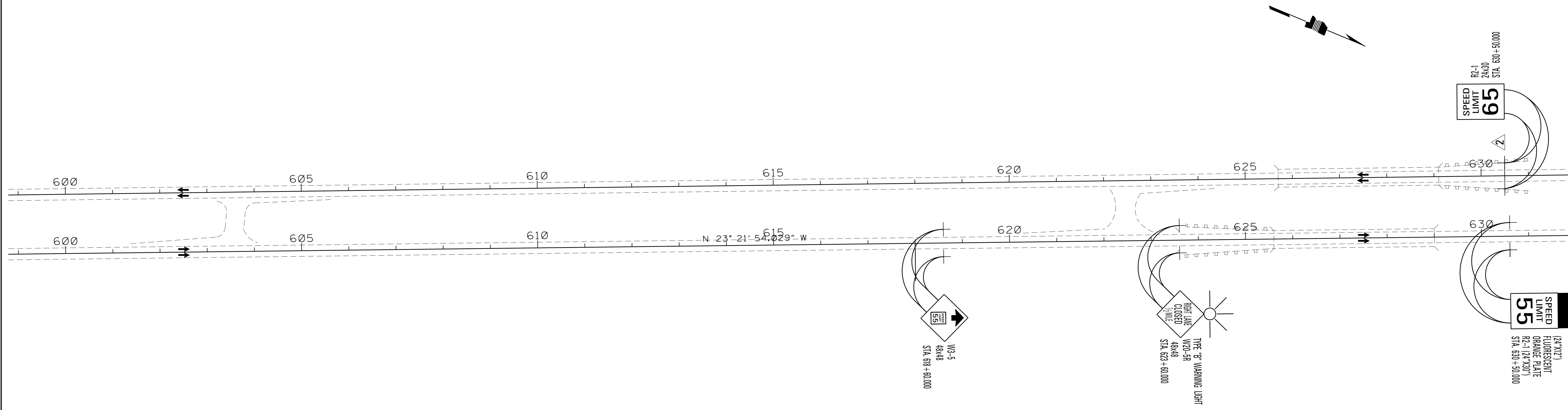

PHASE II

NOTES:

- ALL PAVEMENT MARKINGS SHOWN ON THIS SHEET SHALL BE PAID FOR AS TEMPORARY.
- ALL TRAFFIC CONTROL ITEMS SHOWN ON THIS SHEET SHALL BE PAID FOR UNDER THE APPROPRIATE PAY ITEMS.
- SEE SPECIAL DESIGN WK. NO. TCP-SC FOR DETAILS ON SHOULDER CLOSURES, THE PLACEMENT OF DRUMS, AND THE LOW SHOULDER SIGN (W8-9).

MISSISSIPPI DEPARTMENT OF TRANSPORTATION TRAFFIC CONTROL U.S. HWY. 61 PHASE I (IN PLACE)		 WORKING NUMBER TC-4
WILKINSON COUNTY PROJECT NO.: NHPP-0009-01(129)		
REVISIONS # REVISED SIGNS # REVISED TRAFFIC CONTROL DATE	BY BJR BJR DATE	FILENAME: TC4 - BR.DGN DESIGN TEAM: ROBERTS CHECKED DATE: 8/15/14
		SHEET NUMBER 61

9/8/2014 8:42 AM TC4 - BR.DGN

ADDENDUM

STATE	PROJECT NO.
MISS.	NHPP-0009-01(129)

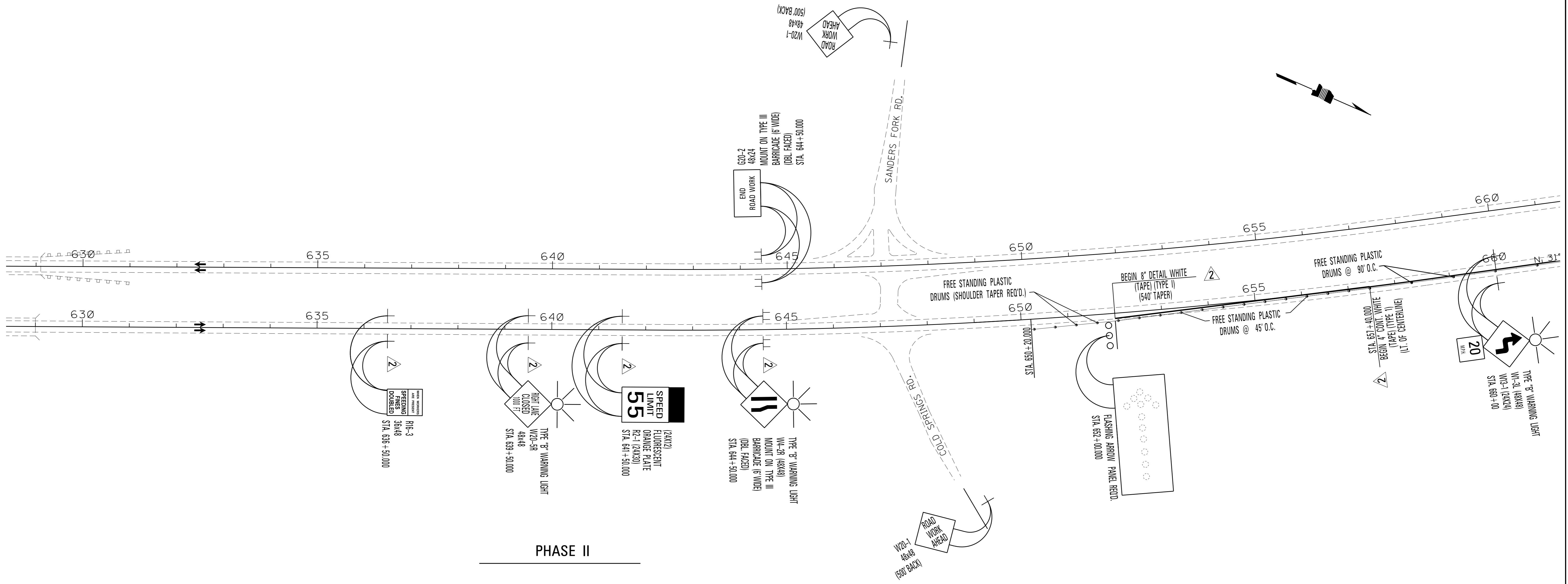

NOTES:

ALL PAVEMENT MARKINGS SHOWN ON THIS SHEET SHALL BE PAID FOR AS TEMPORARY.

ALL TRAFFIC CONTROL ITEMS SHOWN ON THIS SHEET SHALL BE PAID FOR UNDER THE APPROPRIATE PAY ITEMS.

SEE SPECIAL DESIGN WK. NO. TCP-SC FOR DETAILS ON SHOULDER CLOSURES, THE PLACEMENT OF DRUMS, AND THE LOW SHOULDER SIGN (W8-9).

MISSISSIPPI DEPARTMENT OF TRANSPORTATION		TRAFFIC CONTROL	
U.S. HWY. 61		PHASE I (IN PLACE)	
WILKINSON COUNTY		PROJECT NO.: NHPP-0009-01(129)	
FILENAME: TC5 - BR.DGN		DATE: 8/15/14	
DESIGN TEAM	ROBERTS	CHECKED	
WORKING NUMBER		TC-5	
SHEET NUMBER		62	

9/8/2014 8:42 AM TC5 - BR.DGN

ADDENDUM

STATE	PROJECT NO.
MISS.	NHPP-0009-01(129)

9/8/2014 8:42 AM TC6 - BR.DGN

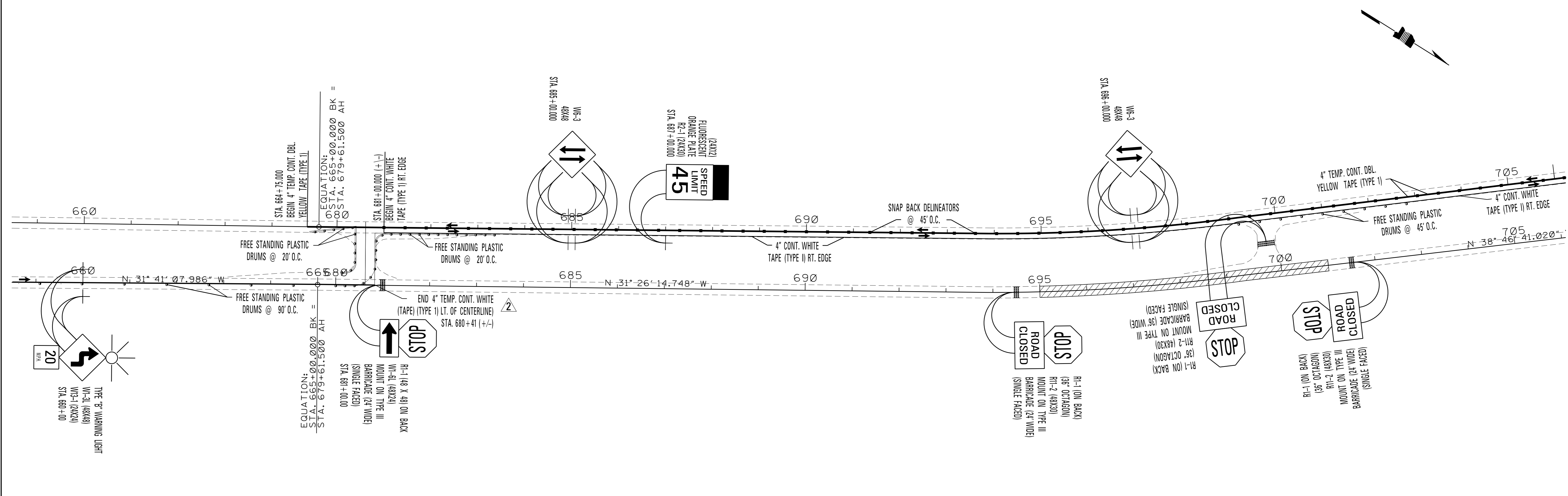

PHASE II

NOTES:

- ALL PAVEMENT MARKINGS SHOWN ON THIS SHEET SHALL BE PAID FOR AS TEMPORARY.
- ALL TRAFFIC CONTROL ITEMS SHOWN ON THIS SHEET SHALL BE PAID FOR UNDER THE APPROPRIATE PAY ITEMS.
- SEE SPECIAL DESIGN WK. NO. TCP-SC FOR DETAILS ON SHOULDER CLOSURES, THE PLACEMENT OF DRUMS, AND THE LOW SHOULDER SIGN (W8-9).

*** INDICATES NEW CONSTRUCTION AREA ***

MISSISSIPPI DEPARTMENT OF TRANSPORTATION	
TRAFFIC CONTROL	
U.S. HWY. 61	
PHASE I (IN PLACE)	
WILKINSON COUNTY	
PROJECT NO.: NHPP-0009-01(129)	
FILENAME: TC6 - BR.DGN	
DESIGN TEAM	ROBERTS CHECKED DATE 8/15/14
WORKING NUMBER	TC-6
SHEET NUMBER	63



ADDENDUM

STATE	PROJECT NO.
MISS.	NHPP-0009-01(129)

PLAN DIVISION
MISSISSIPPI DEPARTMENT OF TRANSPORTATION

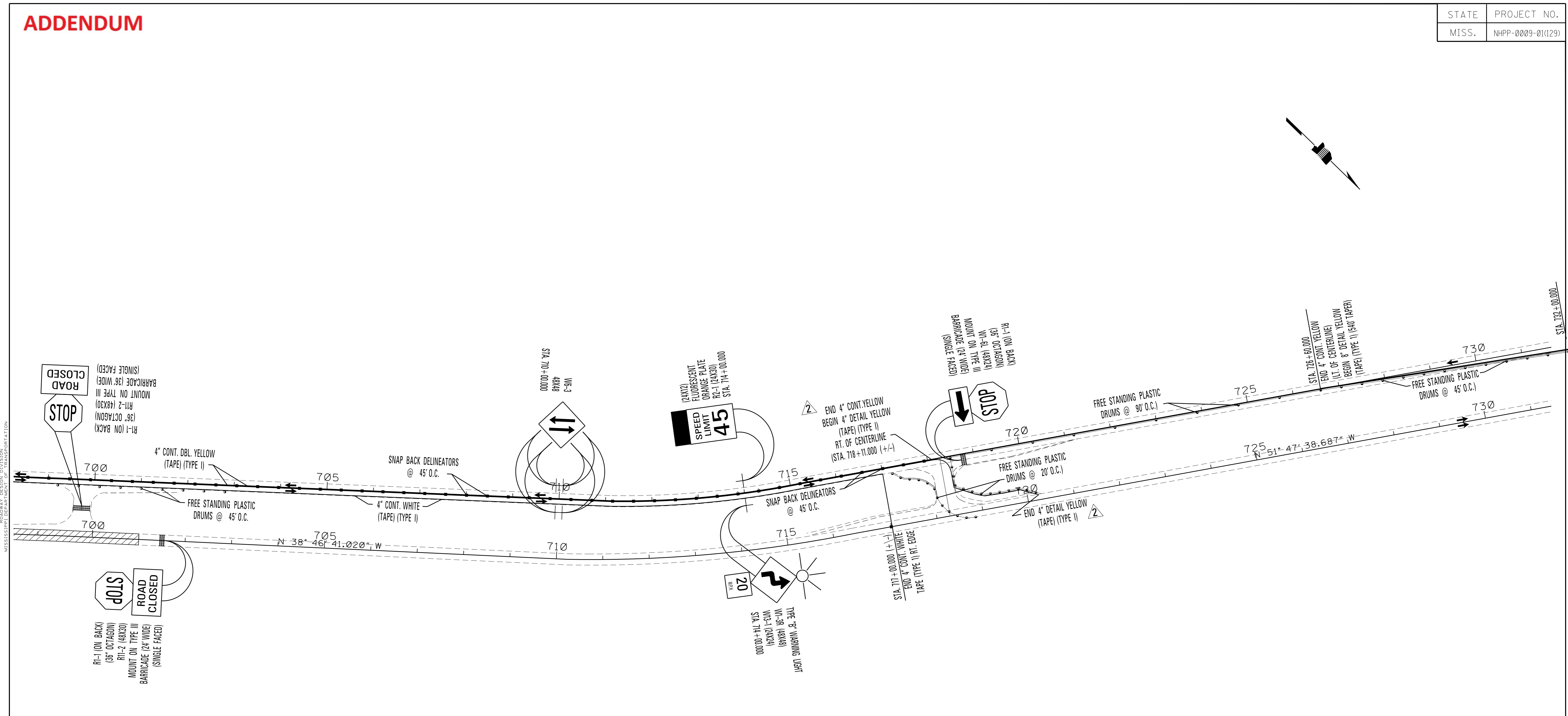

PHASE II

NOTES:

- ALL PAVEMENT MARKINGS SHOWN ON THIS SHEET SHALL BE PAID FOR AS TEMPORARY.
- ALL TRAFFIC CONTROL ITEMS SHOWN ON THIS SHEET SHALL BE PAID FOR UNDER THE APPROPRIATE PAY ITEMS.
- SEE SPECIAL DESIGN WK. NO. TCP-SC FOR DETAILS ON SHOULDER CLOSURES, THE PLACEMENT OF DRUMS, AND THE LOW SHOULDER SIGN (W8-9).

*** INDICATES NEW CONSTRUCTION AREA ***

MISSISSIPPI DEPARTMENT OF TRANSPORTATION TRAFFIC CONTROL	
U.S. HWY. 61 PHASE I (IN PLACE)	
WILKINSON COUNTY PROJECT NO.: NHPP-0009-01(129)	
FILENAME: TC7 - BR.DGN DESIGN TEAM: ROBERTS CHECKED: DATE: 8/15/14	
WORKING NUMBER TC-7	SHEET NUMBER 64

9/8/2014 9:01 AM TC7 - BR.DGN

ADDENDUM

STATE	PROJECT NO.
MISS.	NHPP-0009-01(129)

9/8/2014 9:01 AM TC8 - BR.DGN

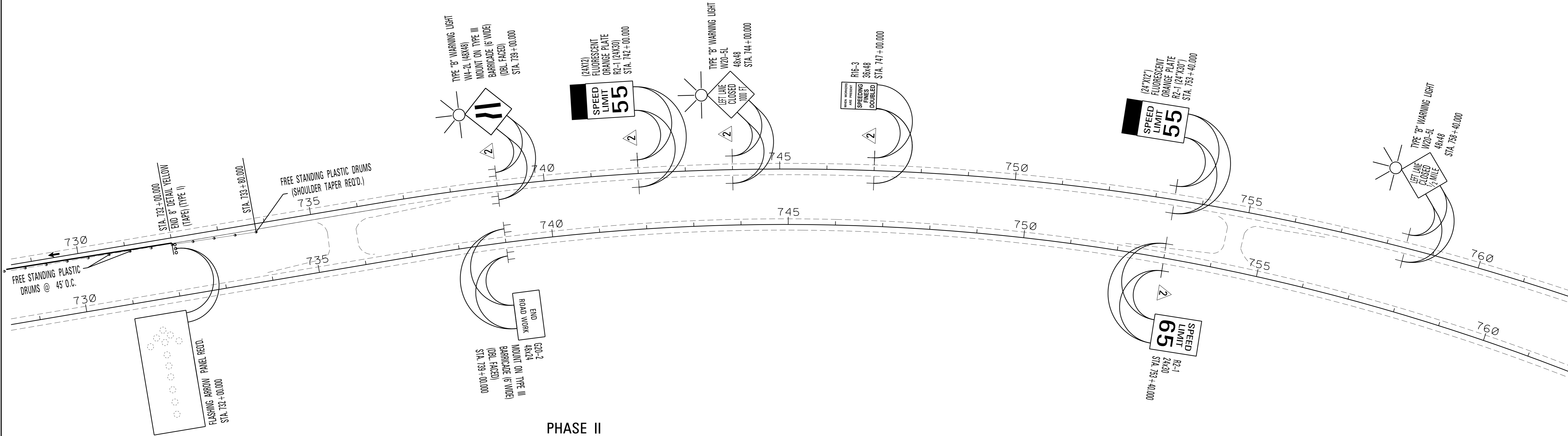

PHASE II

NOTES:

ALL PAVEMENT MARKINGS SHOWN ON THIS SHEET SHALL BE PAID FOR AS TEMPORARY.

ALL TRAFFIC CONTROL ITEMS SHOWN ON THIS SHEET SHALL BE PAID FOR UNDER THE APPROPRIATE PAY ITEMS.

SEE SPECIAL DESIGN WK. NO. TCP-SC FOR DETAILS ON SHOULDER CLOSURES, THE PLACEMENT OF DRUMS, AND THE LOW SHOULDER SIGN (W8-9).

MISSISSIPPI DEPARTMENT OF TRANSPORTATION TRAFFIC CONTROL U.S. HWY. 61 PHASE I (IN PLACE)		 WORKING NUMBER TC-8
WILKINSON COUNTY PROJECT NO.: NHPP-0009-01(129)		
REVISIONS 08/11/14 DATE	BY BUR REVISION	FILENAME: TC8 - BR.DGN DESIGN TEAM: ROBERTS CHECKED: DATE: 8/15/14
SHEET NUMBER 65		