

STATE OF MISSISSIPPI

MISSISSIPPI DEPARTMENT OF TRANSPORTATION

PLAN AND PROFILE OF PROPOSED STATE HIGHWAY FEDERAL AID PROJECT NO. HSIP-0055-02(250)

COPIAH COUNTY - I-55 FROM 1 MILE SOUTH OF MARTINSVILLE EXIT 56) TO 1 MILE NORTH OF MS 27 (EXIT 72)
 HOLMES COUNTY - I-55 FROM 1 MILE SOUTH OF MS. 14 (EXIT 146) TO CARROLL COUNTY LINE
 CARROLL COUNTY - I-55 FROM HOLMES COUNTY LINE TO 1.5 MILES NORTH OF MS 35/430 (VAIDEN, EXIT 174)

SCALES
 PLAN 1 IN. = 100 FT.
 LAYOUT 1 IN. = 100 FT.

STATE	PROJECT NUMBER	SHEET NO.
MISSISSIPPI	HSIP-0055-02(250)	1

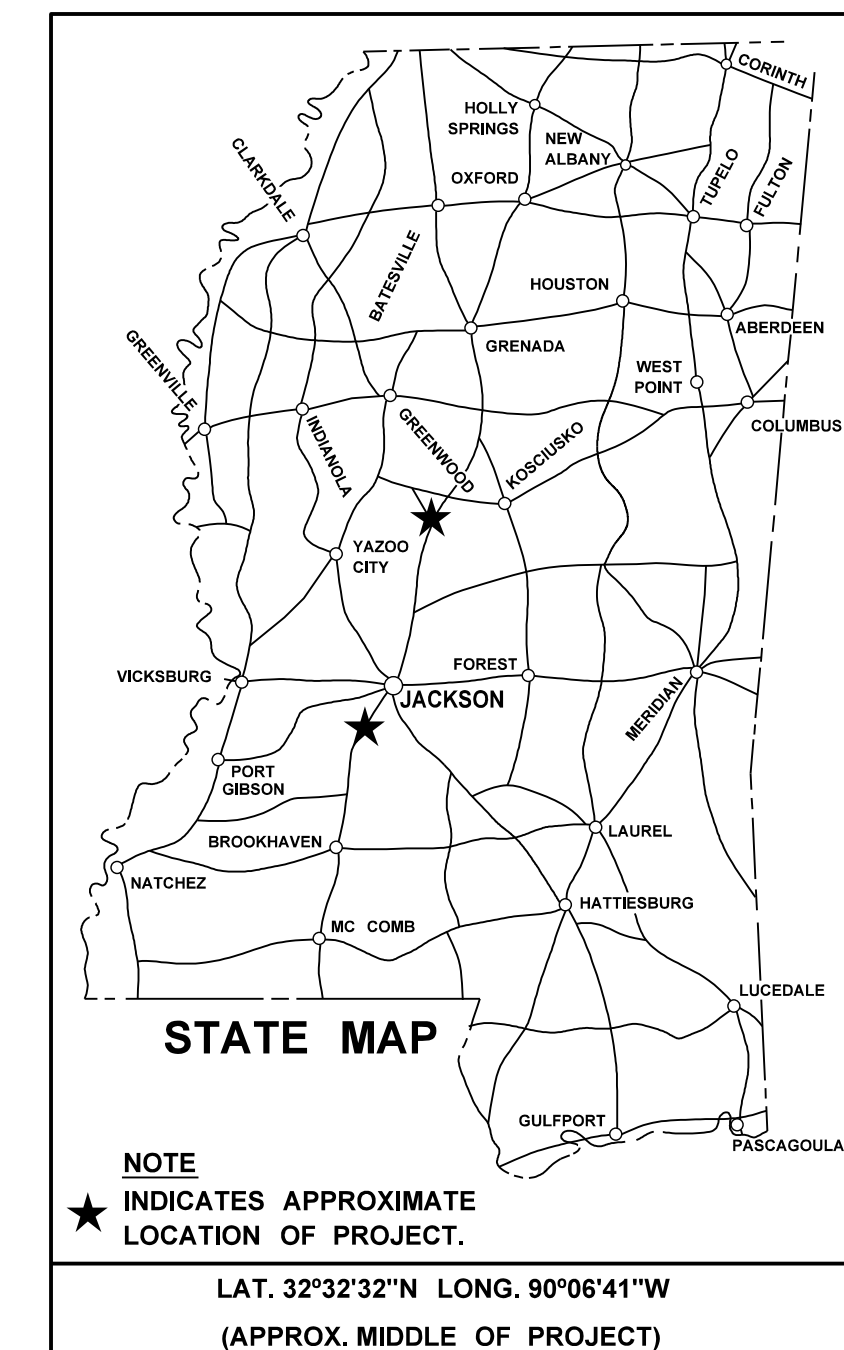

GENERAL INDEX

INCLUDED THIS PROJECT	BEGIN WITH SHEET
<input checked="" type="checkbox"/> ROADWAY	1
<input type="checkbox"/> PERMANENT SIGNS	1001
<input type="checkbox"/> TRAFFIC SIGNALS	2001
<input type="checkbox"/> ITS COMPONENTS	3001
<input type="checkbox"/> LIGHTING	4001
<input type="checkbox"/> (RESERVED)	5001
<input checked="" type="checkbox"/> ROADWAY STANDARD DWGS	6001
<input type="checkbox"/> BOX CULVERT STD. DRAWINGS (LRFD)	7001
<input type="checkbox"/> BOX CULVERT STD. DRAWINGS (STD. SPEC.)	7501
<input type="checkbox"/> BRIDGE	8001
<input checked="" type="checkbox"/> CROSS SECTIONS	9001

LENGTH DATA

LENGTH OF CABLE BARRIER COPIAH COUNTY	42,215 FT.	7.995 MI.
LENGTH OF CABLE BARRIER HOLMES COUNTY	78,842 FT.	14.932 MI.
LENGTH OF CABLE BARRIER CARROLL COUNTY	36,313 FT.	6.877 MI.
LENGTH OF PROJECT (GROSS)		29.804 MI.

▲ E.O.P STA. 1234 + 14.23

▲ B.O.P STA. 395 + 80.00

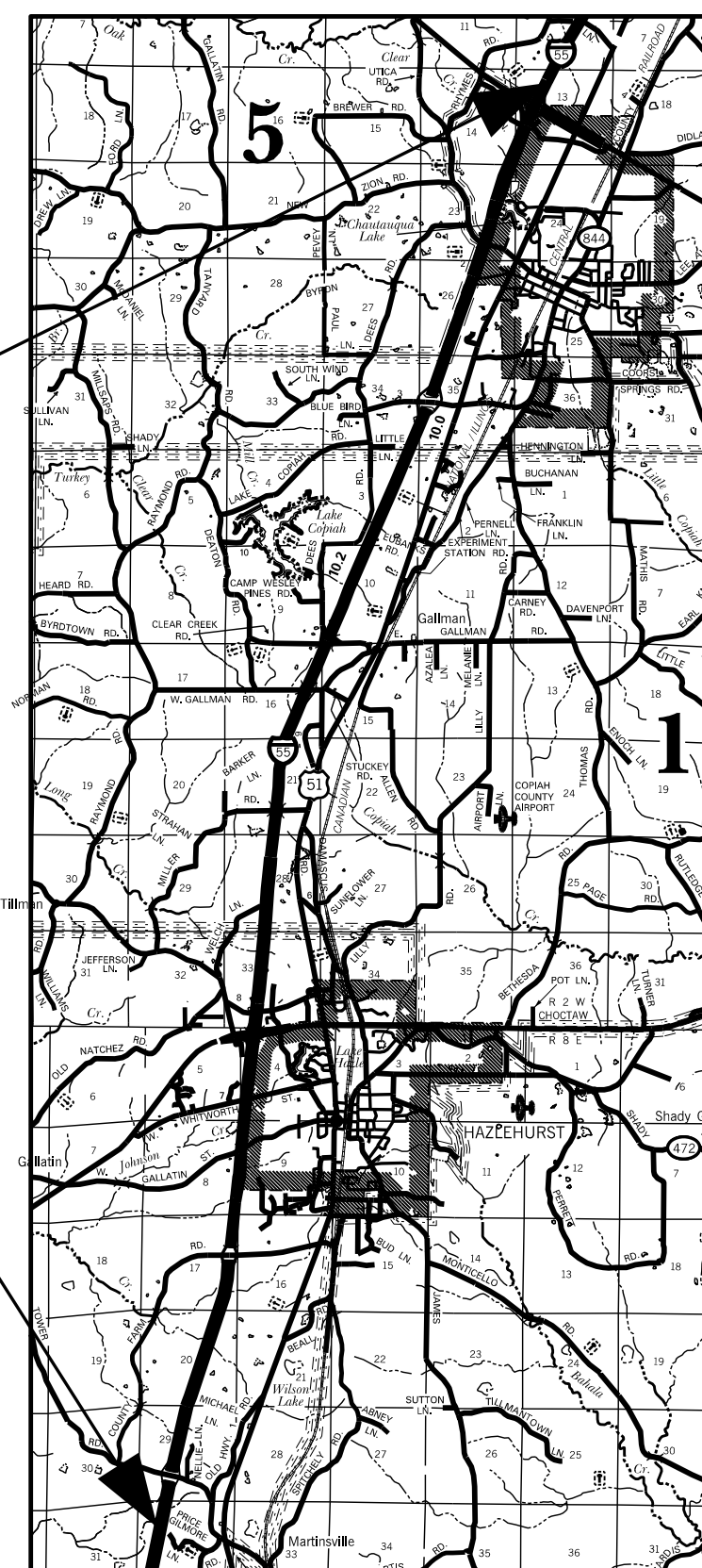

COPIAH COUNTY
 FMS. CONST. NO.
 106997/302000

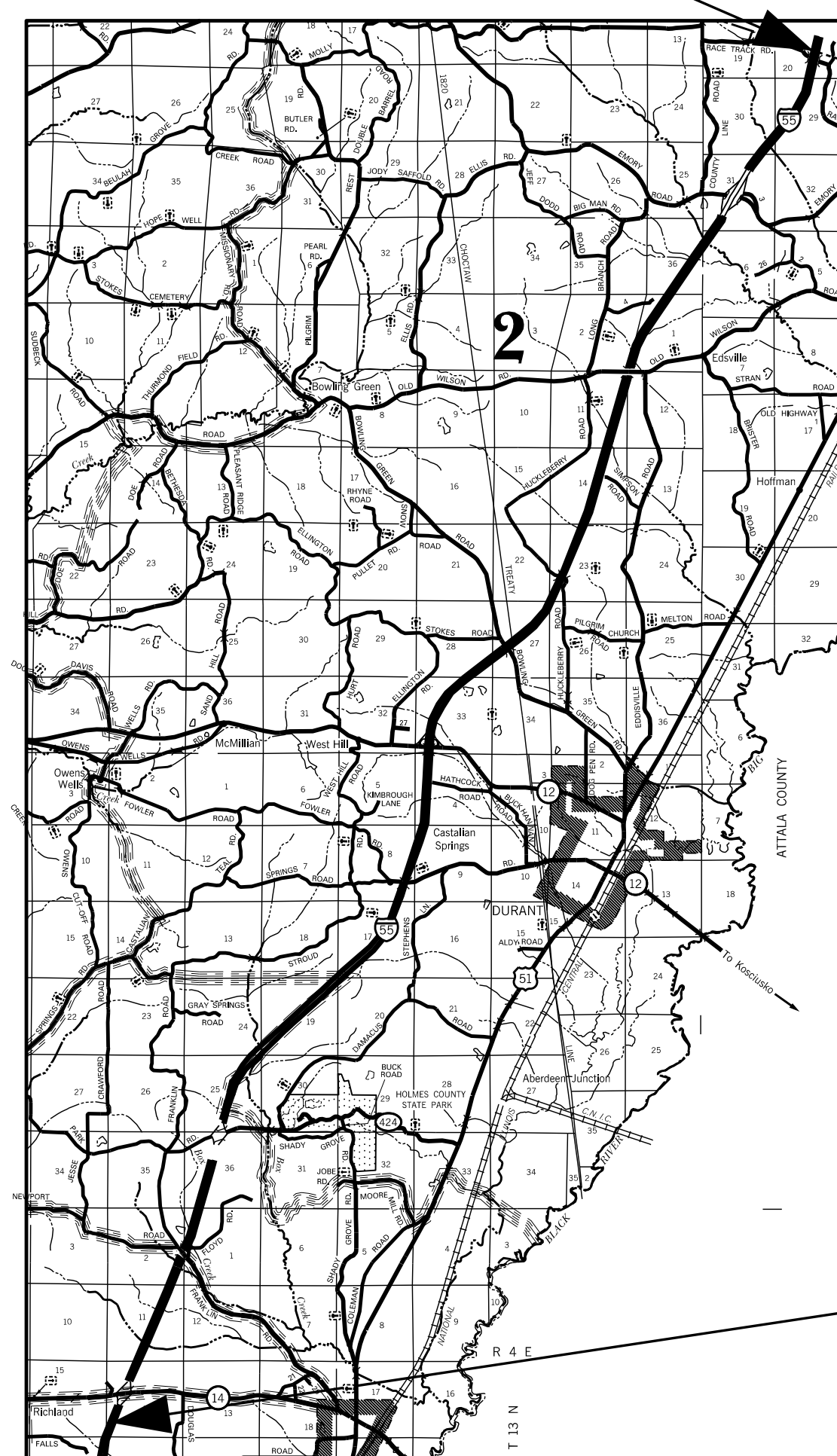

HOLMES COUNTY
 FMS. CONST. NO.
 106997/303000

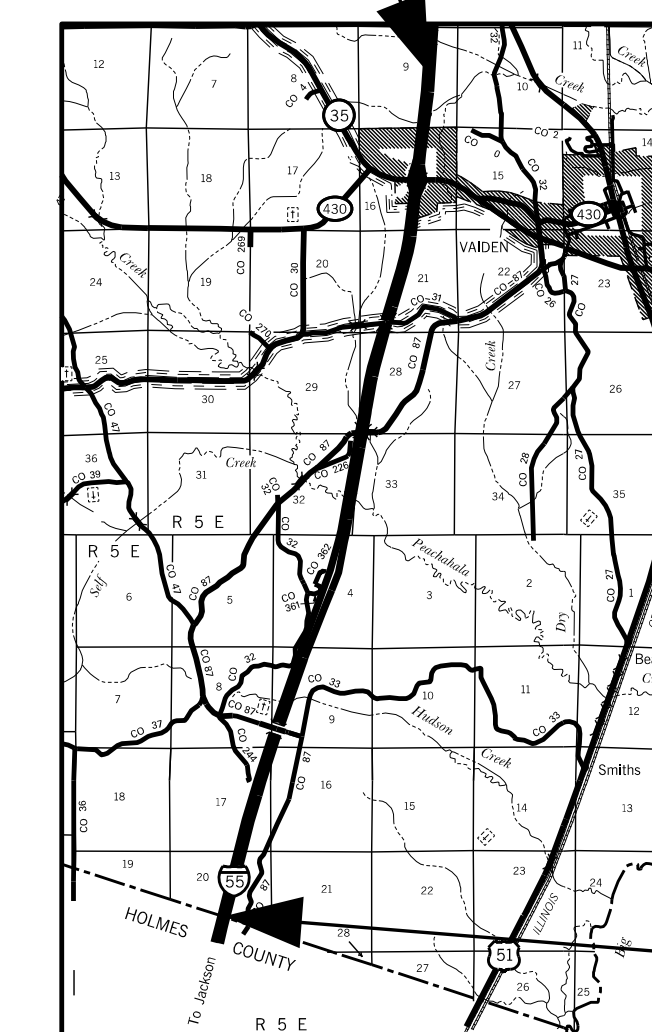

CARROLL COUNTY
 FMS. CONST. NO.
 106997/301000

▲ B.O.P STA. 0 + 00.00

▲ B.O.P STA. 170 + 00.00

CONVENTIONAL SYMBOLS

- COUNTY LINE -----
- TOWN CORPORATION LINE -----
- SECTION LINE -----
- EXISTING ROAD OR TRAVELED WAY -----
- PROPOSED ROAD OR TRAVELED WAY -----
- RAILROAD -----
- SURVEY LINE -----
- BRIDGES -----

DESIGN CONTROL	
MPH = V (SPEED DESIGN)	
ADT () = : ADT () =	
DH = : D = % T = %	
PERMITS ACQUIRED BY MDT	
WETLANDS AND WATERS PERMITS (NECESSARY FOR ULTIMATE IMPROVEMENTS ONLY):	
	WATERS WETLANDS
NATIONWIDE #14	<input type="checkbox"/> <input type="checkbox"/>
NATIONWIDE (OTHER)*	<input type="checkbox"/> <input type="checkbox"/>
GENERAL*	<input type="checkbox"/> <input type="checkbox"/>
INDIVIDUAL (404)*	<input type="checkbox"/> <input type="checkbox"/>
* ACQUISITION OF PERMITS FOR TEMPORARY IMPACTS DURING CONSTRUCTION ARE THE RESPONSIBILITY OF THE CONTRACTOR	
STORMWATER PERMIT <input checked="" type="checkbox"/>	
Y	REQUIRED, CNOI SUBMITTED BY MDT (DISTURBED AREA = 5 ACRES)
S	REQUIRED, CNOI TO BE SUBMITTED BY CONTRACTOR (1 TO 4.99 ACRES)
N	NO STORMWATER PERMIT REQUIRED (<1 ACRE)
APPROVED BY: _____	

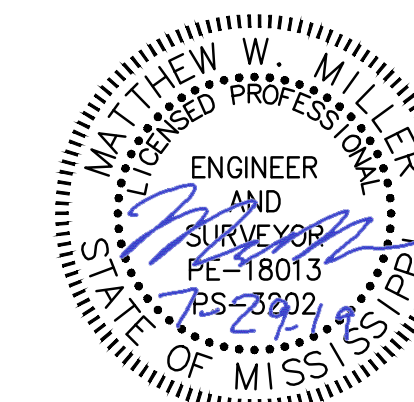

P S & E DATE: 8-7-19	
APPROVED:	
DEPUTY EXECUTIVE DIRECTOR / CHIEF ENGINEER	
EXECUTIVE DIRECTOR	
MDOT MISSISSIPPI DEPARTMENT OF TRANSPORTATION	

9/17/2019 8:53 AM TITLE.DGN

1st O.REV.

STATE	PROJECT NO.
MISS.	HSIP-0055-02(250)

DESCRIPTION OF SHEET	WKG. NO.	SH. NO.	DESCRIPTION OF SHEET	WKG. NO.	SH. NO.
TITLE SHEET		1	COPIAH COUNTY SECTION 3 STA. 1131+00.000 - STA. 1148+55.724 COPIAH COUNTY SECTION 4 STA. 1200+50.000 - STA. 1234+14.234 HOLMES COUNTY SECTION 1 STA. 0+00.000 - STA. 64+00.000 HOLMES COUNTY SECTION 1 STA. 64+00.000 - STA. 128+00.000 HOLMES COUNTY SECTION 1 STA. 128+00.000 - STA. 192+50.000 HOLMES COUNTY SECTION 1 STA. 192+50.000 - STA. 255+70.173 HOLMES COUNTY SECTION 2 STA. 0+00.000 - STA. 63+00.000 HOLMES COUNTY SECTION 2 STA. 63+00.000 - STA. 71+97.177 HOLMES COUNTY SECTION 3 STA. 0+00.000 - STA. 63+00.000 HOLMES COUNTY SECTION 3 STA. 63+00.000 - STA. 127+00.000 HOLMES COUNTY SECTION 3 STA. 127+00.000 - STA. 191+00.000 HOLMES COUNTY SECTION 3 STA. 191+00.000 - STA. 255+00.000 HOLMES COUNTY SECTION 3 STA. 255+00.000 - STA. 288+62.496 HOLMES COUNTY SECTION 4 STA. 0+00.000 - STA. 63+00.000 HOLMES COUNTY SECTION 4 STA. 63+00.000 - STA. 127+00.000 HOLMES / CARROLL COUNTY SECTION 4 STA. 127+00.000 - STA. 191+00.000 CARROLL COUNTY SECTION 4 STA. 191+00.000 - STA. 255+00.000 CARROLL COUNTY SECTION 4 STA. 255+00.000 - STA. 299+33.704 CARROLL COUNTY SECTION 5 STA. 0+00.000 - STA. 63+00.000 CARROLL COUNTY SECTION 5 STA. 63+00.000 - STA. 127+00.000 CARROLL COUNTY SECTION 5 STA. 127+00.000 - STA. 191+00.000 CARROLL COUNTY SECTION 5 STA. 191+00.000 - STA. 241+97.685	ECP7	57
DETAILED INDEX AND GENERAL NOTES SHEETS (4)				ECP8	58
DETAILED INDEX	DI-1	2		ECP9	59
DETAILED INDEX	DI-2	3		ECP10	60
GENERAL NOTES	GN-1	4		ECP11	61
GENERAL NOTES	GN-2	5		ECP12	62
TYPICAL SECTION SHEETS (2)				ECP13	63
TYPICAL SECTION - I-55 MEDIAN CABLE BARRIER LOCATION RT & LT (REGRADE DITCH)	TS-1	6		ECP14	64
TYPICAL SECTION - GRATE CONNECTION	TS-2	7		ECP15	65
SUMMARY OF QUANTITIES (4)				ECP16	66
SUMMARY OF QUANTITIES CARROLL COUNTY	SQ-1	8		ECP17	67
SUMMARY OF QUANTITIES COPIAH COUNTY	SQ-2	9		ECP18	68
SUMMARY OF QUANTITIES HOLMES COUNTY	SQ-3	10		ECP19	69
SUMMARY OF QUANTITIES TOTAL	SQ-4	11		ECP20	70
ESTIMATED QUANTITIES (7)				ECP21	71
ESTIMATED QUANTITIES	EQ-1	12		ECP22	72
ESTIMATED QUANTITIES	EQ-2	13		ECP23	73
ESTIMATED QUANTITIES	EQ-3	14		ECP24	74
ESTIMATED QUANTITIES	EQ-4	15		ECP25	75
ESTIMATED QUANTITIES	EQ-5	16		ECP26	76
ESTIMATED QUANTITIES	EQ-6	17		ECP27	77
ESTIMATED QUANTITIES	EQ-7	18		ECP28	78
PLAN SHEETS (28)			MISCELLANEOUS SHEETS (1)		
COPIAH COUNTY SECTION 1 STA. 395+80.000 - STA. 454+81.238	3	19	VEGETATION SCHEDULE	VS-1	79
COPIAH COUNTY SECTION 2 STA. 545+69.000 - STA. 609+00.000	4	20	STANDARD DRAWINGS (29)		
COPIAH COUNTY SECTION 2 STA. 609+00.000 - STA. 673+00.000	5	21	CONCRETE PAVEMENT JOINTS	PJ-1	6004
COPIAH COUNTY SECTION 2 STA. 673+00.000 - STA. 728+41.096	6	22	CONCRETE PAVEMENT JOINTS (LONGITUDINAL)	PJ-2	6005
COPIAH COUNTY SECTION 3 STA. 1003+95.000 - STA. 1067+00.000	7	23	TYPICAL TEMPORARY EROSION CONTROL/SEDIMENT CONTROL APPLICATIONS	ECD-1	6101
COPIAH COUNTY SECTION 3 STA. 1067+00.000 - STA. 1131+00.000	8	24	DETAILS OF SEDIMENT BARRIER APPLICATIONS	ECD-2	6102
COPIAH COUNTY SECTION 3 STA. 1131+00.000 - STA. 1148+55.724	9	25	DETAILS OF SILT FENCE INSTALLATION	ECD-3	6103
COPIAH COUNTY SECTION 4 STA. 1200+50.000 - STA. 1234+14.234	10	26	DITCH CHECK STRUCTURES, TYPICAL APPLICATIONS AND DETAILS	ECD-4	6104
HOLMES COUNTY SECTION 1 STA. 0+00.000 - STA. 64+00.000	11	27	TEMPORARY EROSION, SEDIMENT, AND WATER POLLUTION CONTROL MEASURES (SILT FENCE AND HAY BALE DITCH CHECKS)	ECD-5	6105
HOLMES COUNTY SECTION 1 STA. 64+00.000 - STA. 128+00.000	12	28	DETAILS OF EROSION CONTROL WATTLE DITCH CHECK	ECD-6	6106
HOLMES COUNTY SECTION 1 STA. 128+00.000 - STA. 192+50.000	13	29	TYPICAL APPLICATIONS AND DETAILS FOR INLET CONSTRUCTION	ECD-11	6111
HOLMES COUNTY SECTION 1 STA. 192+50.000 - STA. 255+70.173	14	30	INLET PROTECTION DETAILS OF WATTLES	ECD-13	6113
HOLMES COUNTY SECTION 2 STA. 0+00.000 - STA. 63+00.000	15	31	INLET PROTECTION DETAILS OF MANUFACTURED INLET PROTECTION DEVICE	ECD-14	6114
HOLMES COUNTY SECTION 2 STA. 63+00.000 - STA. 71+97.177	16	32	DETAILS OF TYPICAL DITCH TREATMENTS	DT-1	6123
HOLMES COUNTY SECTION 3 STA. 0+00.000 - STA. 63+00.000	17	33	TRAFFIC CONTROL PLAN FOR POSTED SPEED LIMIT OF 65 OR 70 MPH (INTERSTATES AND OTHER 4-LANE DIVIDED HIGHWAYS) (MEDIAN LANE OR OUTSIDE LANE CLOSURE) (EXTENDED PERIOD)	TCP-4	6354
HOLMES COUNTY SECTION 3 STA. 63+00.000 - STA. 127+00.000	18	34	TRAFFIC CONTROL PLAN FOR POSTED SPEED LIMIT OF 65 OR 70 MPH (INTERSTATES AND OTHER 4-LANE DIVIDED HIGHWAYS) (MEDIAN LANE OR OUTSIDE LANE CLOSURE) (WORK DAY ONLY)	TCP-5	6355
HOLMES COUNTY SECTION 3 STA. 127+00.000 - STA. 191+00.000	19	35	HIGHWAY SIGN AND BARRICADE DETAILS FOR CONSTRUCTION PROJECTS	TCP-8	6358
HOLMES COUNTY SECTION 3 STA. 191+00.000 - STA. 255+00.000	20	36	DETAILS OF OUTSIDE LANE CLOSURE AT EXIT AND ENTRANCE RAMPS	TCP-10	6360
HOLMES COUNTY SECTION 3 STA. 255+00.000 - STA. 288+62.496	21	37	TRAFFIC CONTROL PLAN FOR TEMPORARY CONSTRUCTION CROSSOVER (WORK DAY ONLY)	TCP-11	6361
HOLMES COUNTY SECTION 4 STA. 0+00.000 - STA. 63+00.000	22	38	LOCATION OF R16-3 SIGNS (SPEEDING FINES DOUBLED)	TCP-15	6365
HOLMES COUNTY SECTION 4 STA. 63+00.000 - STA. 127+00.000	23	39	TRAFFIC CONTROL DETAILS DRUM PLACEMENT AND SHOULDER CLOSURE	TCP-16	6366
HOLMES / CARROLL COUNTY SECTION 4 STA. 127+00.000 - STA. 191+00.000	24	40	MISCELLANEOUS DETAIL SHEET 1. STACKED PIPE JOINTS 2. EXCAVATION AT GRADE POINTS	MDS-1	6425
CARROLL COUNTY SECTION 4 STA. 191+00.000 - STA. 255+00.000	25	41	CONCRETE PIPE COLLAR	PC-1	6503
CARROLL COUNTY SECTION 4 STA. 255+00.000 - STA. 299+33.704	26	42	JUNCTION BOX FOR PIPE CULVERTS	JB-1	6504
CARROLL COUNTY SECTION 5 STA. 0+00.000 - STA. 63+00.000	27	43	TYPE I MEDIAN INLET (24" PIPE AND UNDER)	MI-1	6508
CARROLL COUNTY SECTION 5 STA. 63+00.000 - STA. 127+00.000	28	44	TYPE I MEDIAN INLET (29" TO 51" PIPE)	MI-1A	6509
CARROLL COUNTY SECTION 5 STA. 127+00.000 - STA. 191+00.000	29	45	TYPE II MEDIAN INLET (51" PIPE AND UNDER)	MI-2	6511
CARROLL COUNTY SECTION 5 STA. 191+00.000 - STA. 241+97.685	30	46	MEDIAN INLET FOR BOX CULVERTS (TYPE I & II)	MI-3	6513
			DETAILS OF GRATES FOR MEDIAN INLETS	IG-1	6516
			PAVED INLET APRON AND MEDIAN DITCH PLUG	PA-1	6520
			FLARED END SECTION FOR CONCRETE PIPE	FE-1	6530
SPECIAL DESIGN SHEETS - DETAILED EDGE DRAINAGE (2)					
DRAINAGE DESIGN - EDGE DRAIN DETAIL CONCRETE APRON AND RODENT SCREEN	EDO-1	47			
DRAINAGE DESIGN - DETAIL OF EDGE DRAINS	EDO-2	48			
TRAFFIC CONTROLS PLANS (2)					
TYPICAL TRAFFIC CONTROL LAYOUT - COPIAH	TC-1	49			
TYPICAL TRAFFIC CONTROL LAYOUT - HOLMES/CARROLL	TC-2	50			
EROSION CONTROL PLANS (28)					
COPIAH COUNTY SECTION 1 STA. 395+80.000 - STA. 454+81.238	ECP1	51			
COPIAH COUNTY SECTION 2 STA. 545+69.000 - STA. 609+00.000	ECP2	52			
COPIAH COUNTY SECTION 2 STA. 609+00.000 - STA. 673+00.000	ECP3	53			
COPIAH COUNTY SECTION 2 STA. 673+00.000 - STA. 728+41.096	ECP4	54			
COPIAH COUNTY SECTION 3 STA. 1003+95.000 - STA. 1067+00.000	ECP5	55			
COPIAH COUNTY SECTION 3 STA. 1067+00.000 - STA. 1131+00.000	ECP6	56			

PS & E PLANS-DATE 8/7/2019		
FMS CON. * 106997/301000/302000/303000		
REVISIONS		
DATE	SHEET NO.	BY
8/22	8,9,10,11,60,70	MM
9/16	1,6,7	MM

MISSISSIPPI DEPARTMENT OF TRANSPORTATION															
DETAILED INDEX															
<table border="1"> <tr> <th>DATE</th> <th>REVISION</th> </tr> <tr> <td>9/16/19</td> <td>UPDATED NOTE</td> </tr> <tr> <td>8/22/19</td> <td>ADDED NOTE</td> </tr> </table>	DATE	REVISION	9/16/19	UPDATED NOTE	8/22/19	ADDED NOTE	<table border="1"> <tr> <td>ENGINEER</td> <td>DATE</td> </tr> <tr> <td>AND</td> <td>8/10/19</td> </tr> <tr> <td>REGISTERED PROFESSIONAL</td> <td>PE-18013</td> </tr> <tr> <td>STATE OF MISSISSIPPI</td> <td>PS-2842</td> </tr> </table>	ENGINEER	DATE	AND	8/10/19	REGISTERED PROFESSIONAL	PE-18013	STATE OF MISSISSIPPI	PS-2842
DATE	REVISION														
9/16/19	UPDATED NOTE														
8/22/19	ADDED NOTE														
ENGINEER	DATE														
AND	8/10/19														
REGISTERED PROFESSIONAL	PE-18013														
STATE OF MISSISSIPPI	PS-2842														
PROJ. NO.: HSIP-0055-02(250) COUNTY: COPIAH, HOLMES, CARROLL															
FILENAME: DI-1.dgn DESIGN TEAM: GUEST CHECKED: MM DATE: 7/8/19	WORKING NUMBER DI-1 SHEET NUMBER 2														

9/18/2019 8:43 AM DI-1.DGN

STATE	PROJECT NO.
MISS.	HSIP-0055-02(250)

DESCRIPTION OF SHEET

WKG.
NO.

SH.
NO.

CROSS SECTIONS (279)

COPIAH COUNTY SECTION 1 STA. 395+80.000 - STA. 454+81.238
 COPIAH COUNTY SECTION 2 STA. 545+69.000 - STA. 728+00.000
 COPIAH COUNTY SECTION 3 STA. 1003+95.000 - STA. 1148+55.724
 COPIAH COUNTY SECTION 4 STA. 1200+50.000 - STA. 1234+00.000
 HOLMES COUNTY SECTION 1 STA. 0+00.000 - STA. 255+50.000
 HOLMES COUNTY SECTION 2 STA. 0+00.000 - STA. 71+50.00
 HOLMES COUNTY SECTION 3 STA. 0+31.632 - STA. 288+50.000
 HOLMES COUNTY SECTION 4 STA. 0+00.000 - STA. 170+00.000
 CARROLL COUNTY SECTION 4 STA. 170+00.000 - STA. 299+00.000
 CARROLL COUNTY SECTION 5 STA. 0+00.000 - STA. 241+50.000

9001-9011
 9012-9040
 9041-9062
 9063-9067
 9068-9114
 9115-9127
 9128-9177
 9178-9207
 9207-9235
 9236-9279

8/28/2019 11:36 AM DI-1.DGN

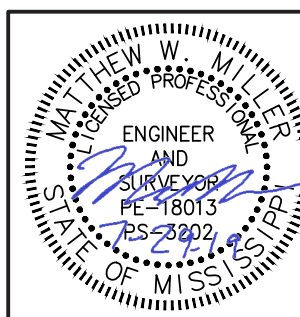
MISSISSIPPI DEPARTMENT OF TRANSPORTATION	
DETAILED INDEX	
	
PROJ. NO.: HSIP-0055-02(250)	WORKING NUMBER
COUNTY: COPIAH, HOLMES, CARROLL	DI-2
FILENAME: DI-1.dgn	SHEET NUMBER
DESIGN TEAM: GUEST	3
CHECKED: MM	DATE: 7/8/19

GENERAL NOTES

- ① THE LOCATION AND SPACING OF SIGNS, SHOWN ON THE TRAFFIC CONTROL PLANS, ARE APPROXIMATE AND MAY BE ADJUSTED AS NECESSARY TO FIT FIELD CONDITIONS.
- ② ALL PLASTIC DRUMS SHALL HAVE A BALLASTING COLLAR MADE FROM RECYCLED TRUCK TIRES OR OTHER SUITABLE MATERIAL.
- ③ ALL TRAFFIC CONTROL DEVICES ON THIS PROJECT SHALL COMPLY WITH PART VI OF THE MUTCD (LATEST EDITION).
- ④ 25% SHRINKAGE FACTOR USED IN THE EARTHWORK CALCULATIONS IS FOR DESIGN ESTIMATING PURPOSES ONLY.
- ⑤ THE CONTRACTOR SHALL BE RESPONSIBLE FOR PROTECTING EXISTING STRUCTURES SUCH AS, BUT NOT LIMITED TO, PIPES, INLETS, APRONS, AND BRIDGES FROM DAMAGE WHICH MIGHT OCCUR DURING CONSTRUCTION. THE CONTRACTOR SHALL REPLACE OR REPAIR, AS DIRECTED BY THE ENGINEER, ANY STRUCTURES DAMAGED DURING THE LIFE OF THE CONTRACT. NO PAYMENT WILL BE MADE FOR REPLACEMENT OR REPAIR OF DAMAGED ITEMS.
- ⑥ ALL PIPE JOINTS ARE TO BE WRAPPED IN 24-INCH WIDE TYPE V GEOTEXTILE FABRIC. ALL PICKUP HOLES SHALL BE PLUGGED AND COVERED WITH TYPE V GEOTEXTILE FABRIC, THE COST OF WHICH SHALL BE ABSORBED IN OTHER ITEMS BID.
- ⑦ VOIDS CREATED BY THE REMOVAL OF, BUT NOT LIMITED TO, POSTS, CONCRETE ANCHORS, AND FOOTINGS SHALL BE BACKFILLED AND TAMPED IN ACCORDANCE WITH SECTION 203 OF THE MISSISSIPPI STANDARD SPECIFICATIONS FOR ROAD AND BRIDGE CONSTRUCTION, THE COST OF WHICH WILL BE ABSORBED IN OTHER ITEMS BID.
- ⑧ WORK ON STRUCTURES FOR THIS PROJECT REQUIRES EXCAVATION IN THE IMMEDIATE VICINITY OF TRAFFIC AND ADJACENT PROPERTIES. THEREFORE, THE RISK OF A FAILURE OCCURRING DURING EXCAVATION REQUIRES THAT EXTREME CAUTION BE EXERCISED. THE CONTRACTOR SHALL BE RESPONSIBLE FOR PLACING WHAT BRACING, SHORING, OR GROUND SUPPORT SYSTEM THAT IS DEEMED NECESSARY TO PREVENT A FAILURE AND PROTECT THE PERSONS WORKING NEAR THE EXCAVATION, THE PUBLIC THAT MAY BE ABOVE THE EXCAVATION, OR ANY STRUCTURES ADJACENT TO THE EXCAVATION. ALL COSTS FOR DESIGNING, DRAWING, AND CONSTRUCTING THE FACILITY SHALL BE INCLUDED IN THE PRICE BID FOR CONTRACT ITEMS.
- ⑨ THE EROSION CONTROL DEVICES REFERENCED IN THESE PLANS ARE A MINIMUM REQUIREMENT. IT IS THE RESPONSIBILITY OF THE CONTRACTOR TO ENSURE THAT SILT DOES NOT LEAVE THE RIGHT OF WAY OR CONTAMINATE WATERS OF THE U. S. DURING CONSTRUCTION. THE CONTRACTOR SHALL SUBMIT AN EROSION CONTROL PLAN PRIOR TO COMMENCEMENT OF WORK AND MAINTAIN THE PLAN DURING CONSTRUCTION. ANY ADDITIONAL SILT BASINS NOT SHOWN IN THE PLANS SHALL BE INCLUDED IN THE CONTRACTOR'S EROSION CONTROL PLAN PRIOR TO SUBMITTING FOR APPROVAL.
- ⑩ WATTLE EROSION CHECKS, SILT FENCING, OR OTHER APPROVED BMPS SHALL BE USED ALONG THE TOE OF FILL SLOPES, IN DITCHES, AND AROUND INLETS WHERE EROSION IS A PROBLEM.
- ⑪ SIZE OF PROPOSED PAVED DITCHES SHALL MATCH EXISTING PAVED DITCHES. CONTRACTOR SHALL FIELD VERIFY AND MAKE ANY ADJUSTMENTS AS NECESSARY.
- ⑫ WHERE EXISTING SLOPES ARE NEAR TO 6:1, CONTRACTOR SHALL USE TOPSOIL FOR ADJUSTMENT OF SLOPES. TOPSOIL SHALL BE DISKED INTO EXISTING MATERIAL PRIOR TO GRASSING AND SEEDING. TO BE PAID FOR UNDER TOP SOIL PAY ITEM 211-B001.
- ⑬ VEGETATIVE MATERIAL WILL BE REMOVED PRIOR TO PLACEMENT OF BORROW MATERIAL. THE COST OF WHICH SHALL BE ABSORBED IN OTHER ITEMS BID.

GENERAL NOTES

STATE	PROJECT NO.
MISS.	HSIP-0055-02(250)

- ⑭ FLUORESCENT ORANGE SHEETING SHALL BE USED ON ALL CONSTRUCTION AND TRAFFIC CONTROL SIGNS EXCEPT FOR THOSE DESIGNATED IN THE PLANS TO BE BLACK LEGEND AND BORDER ON WHITE BACKGROUND.
- ⑮ THE CONTRACTOR SHALL REPAIR ANY DAMAGE TO THE SURFACE TREATED SHOULDER THAT MIGHT OCCUR DURING CONSTRUCTION. ANY REPAIR TO SHOULDER WILL BE IN ACCORDANCE WITH SECTION 410 OF THE MISSISSIPPI STANDARD SPECIFICATIONS FOR ROAD AND BRIDGE CONSTRUCTION. NO PAYMENT WILL BE MADE FOR REPAIR OF DAMAGED SHOULDER.
- ⑯ CONTRACTOR SHALL VERIFY THAT ALL MEDIAN SLOPES LOCATED ON THE SIDE OF THE MEDIAN IN WHICH THE CABLE BARRIER IS INSTALLED ARE AT A MINIMUM OF 6:1 SLOPES. ANY SLOPES FOUND NOT BE AT A MINIMUM OF 6:1 SHALL BE ADJUSTED TO MEET THIS REQUIREMENT.
- ⑰ THE PROPOSED CABLE BARRIER SHALL BE INSTALLED AT A MINIMUM DISTANCE OF 8' FROM THE DITCH FLOWLINES. PROJECT ENGINEER MAY VARY EXACT LOCATIONS DUE TO FIELD CONDITIONS, BUT THE LOCATION SHALL NOT BE LESS THAN 8' FROM THE DITCH FLOWLINE.
- ⑱ LOCATION OF PROPOSED CABLE BARRIER SHALL BE STAKED BY THE CONTRACTOR PRIOR TO INSTALLATION FOR REVIEW BY THE PROJECT ENGINEER.
- ⑲ MINIMUM REQUIRED DEFLECTIONS REQUIREMENTS BY THE CABLE BARRIER MANUFACTURER SHALL BE MAINTAINED AT ALL BRIDGE PIERS, AND OTHER OBSTRUCTIONS AS DETERMINED BY THE PROJECT ENGINEER.
- ⑳ THE CONTRACTOR SHALL COORDINATE WITH THE CONTRACTOR FROM ADJACENT PROJECT(S) IN IMPLEMENTING THE TRAFFIC CONTROL PLAN AS DIRECTED BY THE ENGINEER. ALL CONFLICTING SIGNS SHALL BE COVERED OR REMOVED AS DIRECTED BY THE ENGINEER.
- ㉑ PRIOR TO EARTHWORK OPERATIONS, THE EXISTING TOP 4" TOPSOIL IS TO BE STRIPPED AND STOCKPILED. AFTER THE GRADING OPERATIONS ARE COMPLETED, SAID TOPSOIL SHALL BE PLACED ON ALL AREAS THAT ARE NOT TO BE PAVED OR OTHERWISE PROTECTED, IN ACCORDANCE WITH SECTION 211 OF THE SPECIFICATIONS, OR THE VEGETATION SCHEDULE (SEE WK. SH. VS-1). EXISTING TOPSOIL AND ALL COSTS ASSOCIATED WITH STRIPPING, HAULING, STOCKPILING, AND PLACEMENT OF THE EXISTING TOPSOIL IS TO BE ABSORBED IN OTHER BID ITEMS.
- ㉒ ALL ADDENDA TO THESE PLANS WILL BE POSTED TO WWW.MDOT.MS.GOV UNDER THE PROPOSAL ADDENDA COLUMN. BIDDERS ARE ADVISED THAT HARD COPIES OF ANY ADDENDA FOR THIS PROJECT WILL NOT BE MAILED. IT IS THE BIDDER'S RESPONSIBILITY TO CHECK AND SEE IF ANY ADDENDA HAVE BEEN POSTED FOR THIS PROJECT.
- ㉓ ANY EXISTING EDGE DRAIN PIPES WHICH ARE IN CONFLICT WITH THE LOCATION OF MEDIAN CABLE BARRIER SHALL BE ADJUSTED. CONCRETE DRAINAGE PADS MAY NEED TO BE REMOVED AT SOME LOCATIONS. VEGETATIVE CONTROL PAD MAY BE USED AS CONCRETE DRAINAGE PAD, COST ABSORBED.
- ㉔ ALL EDGE DRAIN PIPES THAT MUST BE EXTENDED DUE TO EARTHWORK SHALL BE PAID FOR SEPERATELY UNDER PAY ITEM 605-I001.
- ㉕ CONTRACTOR SHALL VERIFY ALL EXISTING PIPE SIZES PRIOR TO ORDERING MATERIALS.

8/28/2019 11:36 AM GN-1.dgn

MISSISSIPPI DEPARTMENT OF TRANSPORTATION	
GENERAL NOTES	
PROJ. NO.: HSIP-0055-02(250) COUNTY: COPIAH, HOLMES, CARROLL	
FILENAME: GN-1.dgn DESIGN TEAM: GUEST CHECKED: MM DATE: 7/8/19	WORKING NUMBER GN-1 SHEET NUMBER 4

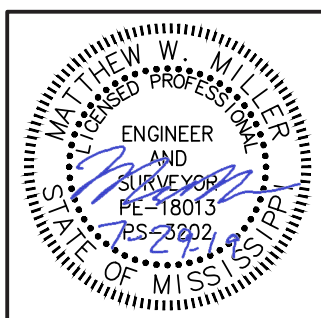

1st O.REV.

STATE	PROJECT NO.
MISS.	HSIP-0055-02(250)

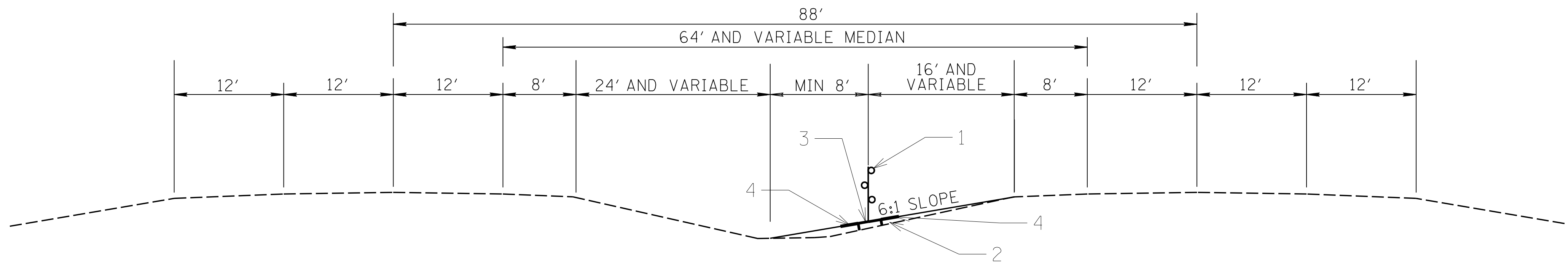

TYPICAL CABLE BARRIER SECTION
I-55 COPIAH COUNTY

SECT 2 STA. 612+50.00-642+30.00, 652+00.00-675+80.00, 678+90.00-728+41.096
 SECT 3 STA. 1039+65.00-1107+05.00, 1107+15.00-1135+50.00
 SECT 4 STA. 1200+50.00-1215+35.00, 1219+40.00-1227+15.00, 1227+30.00-1234+14.234

I-55 HOLMES / CARROLL COUNTY

SECT 1 STA. 30+00.00-138+98.00, 221+10.00-255+70.173
 SECT 2 STA. 0+50.00-30+50.00
 SECT 3 STA. 0+00.00-25+30.00, 56+95.00-271+95.00
 SECT 4 STA. 2+85.00-16+80.00, 21+10.00-51+85.00, 55+00.00-160+00.00, 167+05.00-194+70.00, 195+05.00-273+90.00
 SECT 5 STA. 0+00.00-7+90.00, 12+00.00-16+50.00, 21+00.00-52+95.00, 55+60.00-84+70.00, 84+90.00-114+75.00, 159+80.00-187+85.00

- ① MEDIAN CABLE BARRIER REQ'D
- ② BORROW EXCAVATION REQ'D (CLASS B9) SEE NOTE 1.
- ③ VEGETATIVE PAD (SEE DETAIL A)
- ④ 2' SOLID SODDING REQ'D (BOTH SIDES OF PAD)

NOTE
 1. WHERE EXISTING SLOPE IS NEARLY 6:1, TOPSOIL SHALL BE DISKED INTO EXISTING SLOPE IN LIEU OF B9 MATERIAL. PROJECT ENGINEER SHALL DECIDE LOCATIONS
 2. SLOPE WORK NOT REQ'D FOR FULL LENGTH OF PROJECT. SEE PLAN SHEETS FOR STATION LOCATIONS REQUIRING EARTHWORK FOR COPIAH, HOLMES, AND CARROLL COUNTIES.
 3. BARRIER SHALL BE 8' MINIMUM AND VARIABLE FROM DITCH CENTERLINE.
 4. PAVED DITCH SHALL MATCH EXISTING WIDTH AND STYLE (V-BOTTOM/FLAT BOTTOM).
 5. A 8' MINIMUM DIMENSION TO BE MEASURED FROM TOE OF FLAT BOTTOM DITCH.

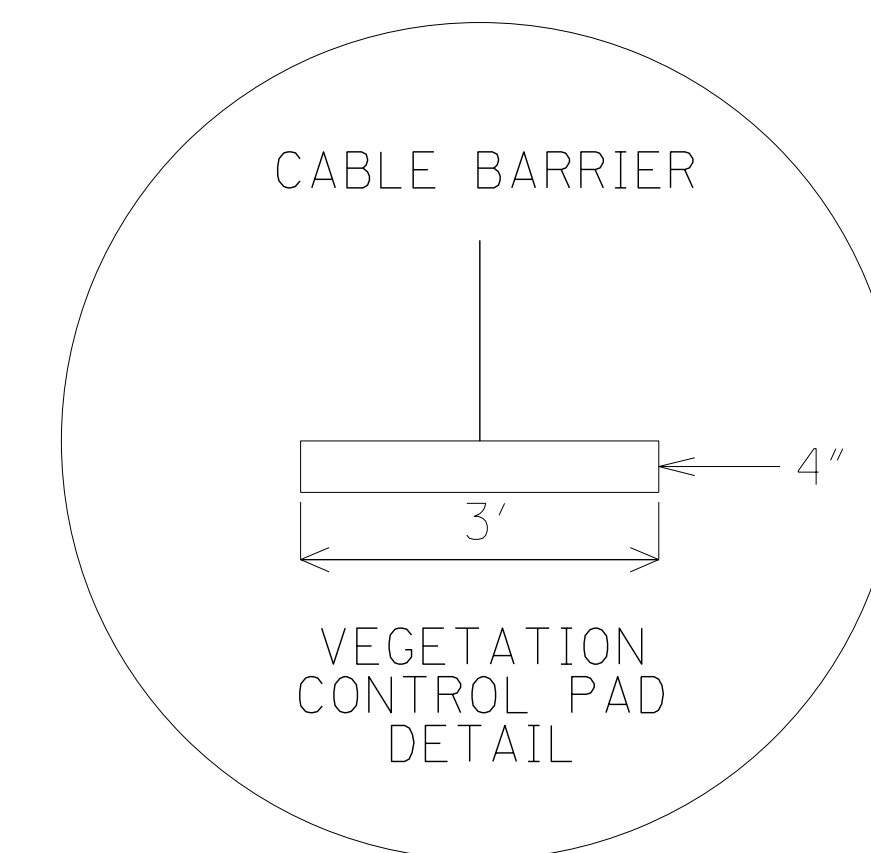

DETAIL A
(REFER TO DT-1 FOR CONSTRUCTION DETAILS)

NOTE:
 EXPANSION JOINTS REQ'D EVERY 20' AND FULL DEPTH CONSTRUCTION JOINTS REQ'D EVERY 200'.
 ⚠️ COST TO BE ABSORBED.

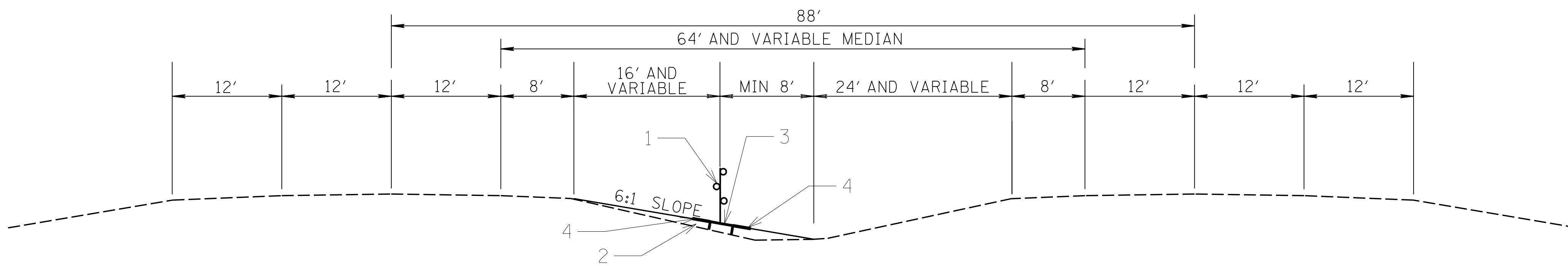

TYPICAL CABLE BARRIER SECTION
I-55 COPIAH COUNTY

SECT. 1 STA. 395+80.00-454+81.238
 SECT 2 STA. 545+69.00-612+10.00, 639+65.00-655+00.00
 SECT 3 STA. 1003+95.00-1042+35.00, 1133+55.00-1148+55.724

I-55 HOLMES / CARROLL COUNTY

SECT 1 STA. 0+00.00-32+60.00, 136+40.00-223+80.00
 SECT 2 STA. 27+90.00-71+97.177
 SECT 3 STA. 24+75.00-59+55.00, 269+00.00-288+62.496
 SECT 4 STA. 271+20.00-299+33.704
 SECT 5 STA. 112+05.00-162+25.00, 191+70.00-241+97.685

MISSISSIPPI DEPARTMENT OF TRANSPORTATION			
TYPICAL SECTION			
PROJ. NO.: HSIP-0055-02(250) COUNTY: COPIAH, HOLMES, CARROLL			
FILENAME: TS-1.dgn		WORKING NUMBER	TS-1
DESIGN TEAM: GUEST		CHECKED: MM	DATE: 7/8/19
DATE: 9/16/19		SHEET NUMBER	
9/16/19		6	

PLAN DIVISION
COPIAH COUNTY
MISSISSIPPI DEPARTMENT OF TRANSPORTATION

9/17/2019 8:53 AM TS-1.dgn

1st O.REV.

STATE	PROJECT NO.
MISS.	HSIP-0055-02(250)

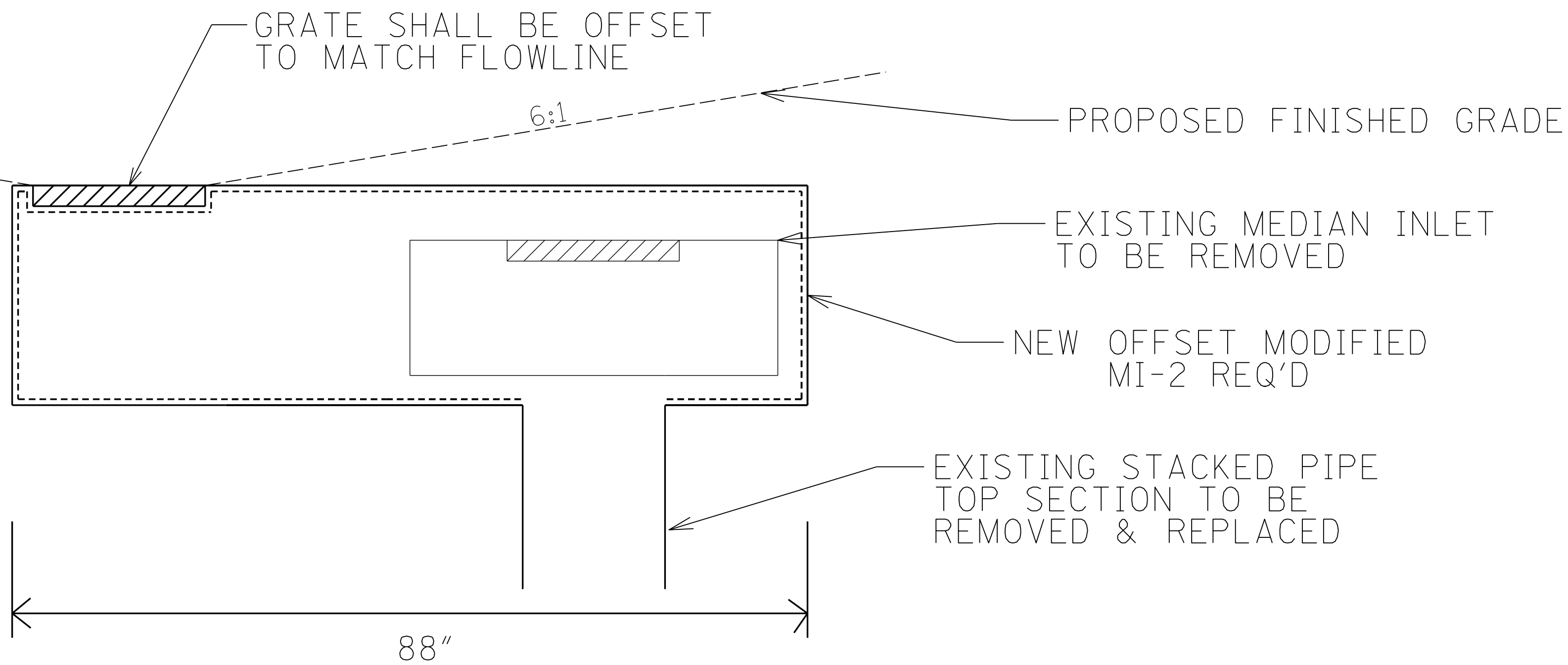

SECTION VIEW

COPIAH COUNTY, SECT. 1 STA. 605+00.000, 626+97.590, 679+83.430, SECT. 3 STA. 1062+35.254

HOLMES COUNTY, SECT. 3 STA. 84+25.730, SECT. 4 STA. 129+22.714

CARROLL COUNTY, SECT. 5 STA. 59+62.089

PROPOSED MODIFIED TYPE I MEDIAN INLET STACKED PIPE CONNECTION

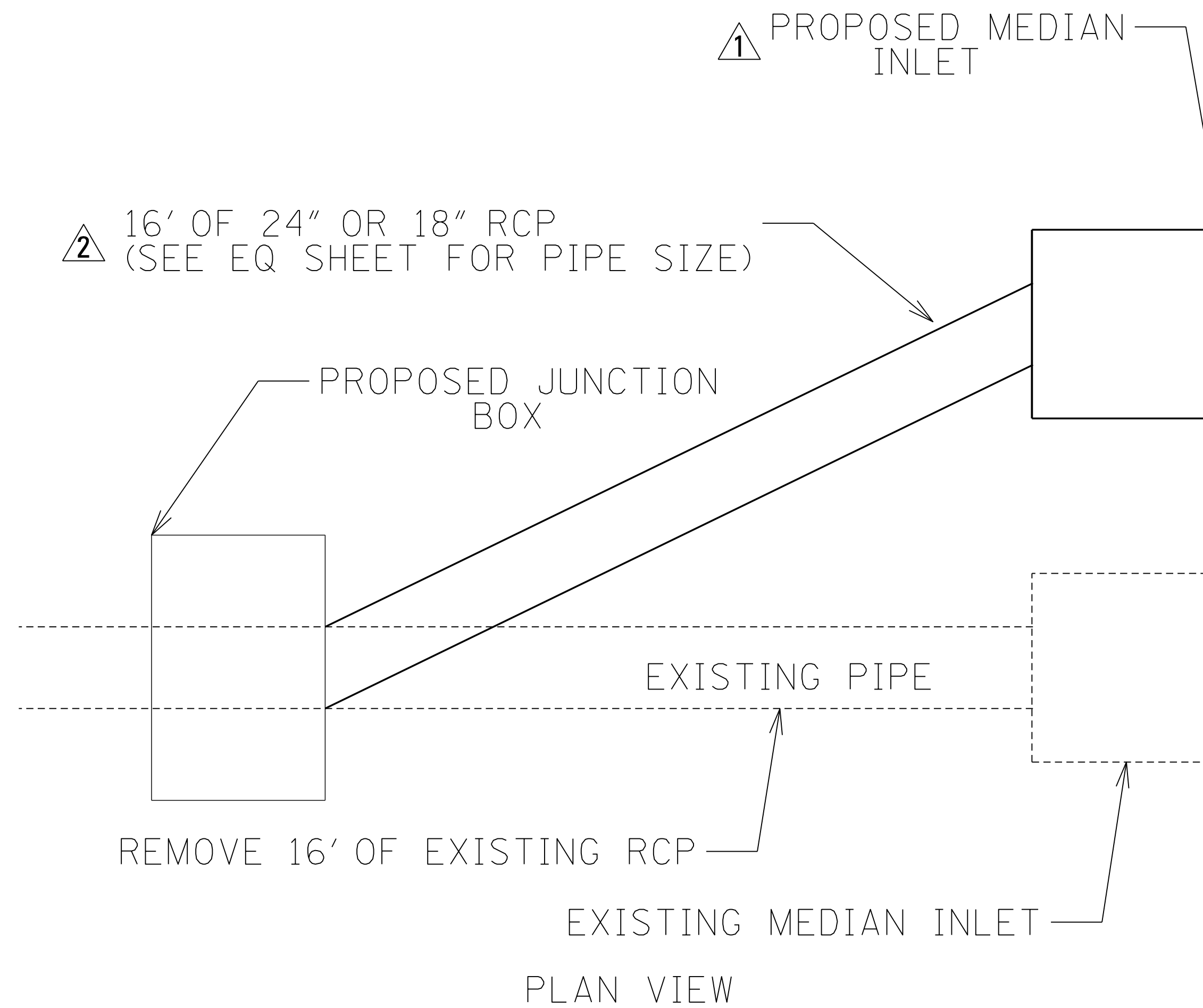

PLAN VIEW

3 HOLMES COUNTY, SECT. 3 STA. 159+86.670, 230+55.110

PROPOSED TYPE I MEDIAN INLET CONNECTION BY JUNCTION BOX

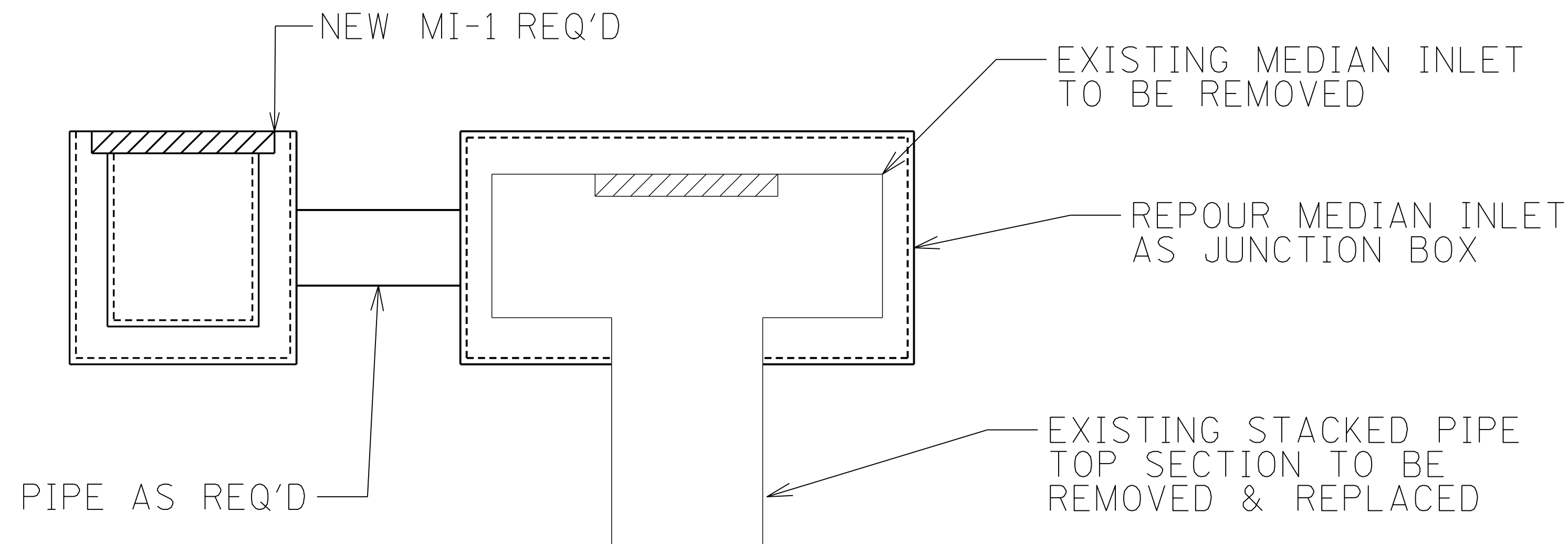

SECTION VIEW

CARROLL COUNTY, SECT. 4 STA. 185+00.000, 211+69.679, SECT. 5 STA. 186+10.635

PROPOSED MODIFIED TYPE I MEDIAN INLET STACKED PIPE CONNECTION

NOTE:
 1. REFER TO MI-2 FOR STEEL DETAILS.
 2. STEEL LENGTHS WILL BE ADJUSTED FOR MODIFIED BOX SIZES.

MISSISSIPPI DEPARTMENT OF TRANSPORTATION			
GRATE CONNECTION TYPICAL SECTION			
PROJ. NO.: HSIP-0055-02(250) COUNTY: COPIAH, HOLMES, CARROLL			
FILENAME: TS-1.dgn		WORKING NUMBER	TS-2
DESIGN TEAM	GUEST	CHECKED	MM
DATE	7/8/19	SHEET NUMBER	7

9/17/2019 8:53 AM TS-1.dgn

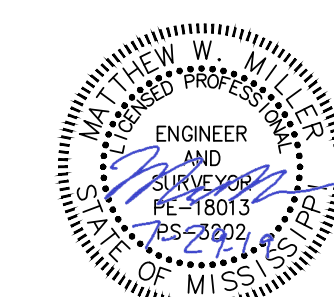

STATE	PROJECT NO.
MISS	HSIP-0055-02(250)/HSIP-0055-02(250)/HSIP-0055-02(250)

SUMMARY OF QUANTITIES (SHEET 1)

PAY ITEM NO.	PAY ITEM	UNIT	CARROLL : 106997-301000	
			Prelim	Final
202-B063	Removal of Concrete Paved Ditch	SY	799	
202-B122	Removal of Edge Drain Outlet	EA	13	
202-B165	Removal of Inlets, All Sizes	EA	11	
202-B191	Removal of Pipe, 8" And Above	LF	46	
203-EX040	Borrow Excavation, AH, LVM, Class B9	CY	1,726	
206-A001	Structure Excavation	CY	52	
211-B001	Topsoil for Slope Treatment, Contractor Furnished	CY	1,086	
216-A001	Solid Sodding	SY	16,722	
217-A001	Ditch Liner	SY	750	
219-A001	Watering	KGAL	334	
221-A001	Concrete Paved Ditch	CY	1,440	
225-A001	Grassing	ACRE	4	
234-A001	Temporary Silt Fence	LF	750	
234-D001	Inlet Siltation Guard	EA	11	
237-A002	Wattles, 20"	LF	500	
246-B001	Rockbags	EA	24	
601-B001	Class "B" Structural Concrete, Minor Structures	CY	15	
602-A001	Reinforcing Steel	LBS	1,027	
603-CA011	18" Reinforced Concrete Pipe, Class III	LF	45	
603-CA040	30" Reinforced Concrete Pipe, Class III	LF	7	
604-B001	Gratings	LBS	2,750	
605-I001	Edge Drain Outlets/Vents	LF	27	
610-A001	Cable Barrier	LF	36,313	
610-B001	Cable Barrier Terminal Section	EA	21	
618-A001	Maintenance of Traffic	LS	1	
618-B001	Additional Construction Signs	SF	1	
620-A001	Mobilization	LS	1	
699-A001	Roadway Construction Stakes	LS	1	

② ⚠
② ⚠
① ⚠

⚠ ① QUANTITY INCLUDES 75 C.Y. FOR PAVED DITCH, 5.5 C.Y. FOR EDGE DRAIN OUTLET, 1,345 C.Y. FOR VEGETATIVE CONTROL PAD, 5.9 C.Y. FOR PAVED APRONS.
⚠ ② 30% SHRINKAGE FACTOR ADDED

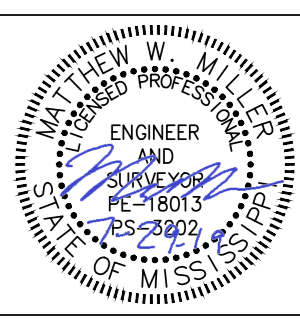
REVISION OF FOOTNOTES	MM	By	MISSISSIPPI DEPARTMENT OF TRANSPORTATION SUMMARY OF QUANTITIES	
Date	08/22/2019		PROJ NO: HSIP-0055-02(250) COUNTY: CARROLL	Working Number SQ-1
			FILENAME: SQ-1 Design Team GUEST Checked MM Date 7/8/19	Sheet Number 8

1st O.REV.

STATE	PROJECT NO.
MISS	HSIP-0055-02(250)/HSIP-0055-02(250)/HSIP-0055-02(250)

SUMMARY OF QUANTITIES (SHEET 2)				
PAY ITEM NO.	PAY ITEM	UNIT	COPIAH : 106997-302000	
			Prelim	Final
202-B063	Removal of Concrete Paved Ditch	SY	156	
202-B122	Removal of Edge Drain Outlet	EA	28	
202-B165	Removal of Inlets, All Sizes	EA	7	
202-B191	Removal of Pipe, 8" And Above	LF	30	
203-EX040	Borrow Excavation, AH, LVM, Class B9	CY	3,678	
206-A001	Structure Excavation	CY	35	
211-B001	Topsoil for Slope Treatment, Contractor Furnished	CY	3,409	
216-A001	Solid Sodding	SY	18,904	
217-A001	Ditch Liner	SY	4,450	
219-A001	Watering	KGAL	375	
221-A001	Concrete Paved Ditch	CY	1,583	
225-A001	Grassing	ACRE	21	
234-A001	Temporary Silt Fence	LF	4,450	
234-D001	Inlet Siltation Guard	EA	8	
237-A002	Wattles, 20"	LF	500	
246-B001	Rockbags	EA	58	
601-B001	Class "B" Structural Concrete, Minor Structures	CY	14	
602-A001	Reinforcing Steel	LBS	1,069	
603-CA011	18" Reinforced Concrete Pipe, Class III	LF	40	
603-CA026	24" Reinforced Concrete Pipe, Class III	LF	35	
603-CA066	42" Reinforced Concrete Pipe, Class III	LF	2	
603-CB004	24" Reinforced Concrete End Section	EA	5	
604-B001	Gratings	LBS	2,000	
605-I001	Edge Drain Outlets/Vents	LF	11	
610-A001	Cable Barrier	LF	42,215	
610-B001	Cable Barrier Terminal Section	EA	28	
618-A001	Maintenance of Traffic	LS	1	
618-B001	Additional Construction Signs	SF	1	
620-A001	Mobilization	LS	1	
699-A001	Roadway Construction Stakes	LS	1	

- ① QUANTITY INCLUDES 14.2 C.Y. FOR PAVED DITCH, 0.7 C.Y. FOR EDGE DRAIN OUTLET, 1,563 C.Y. FOR VEGETATIVE CONTROL PAD, 4.4 C.Y. FOR PAVED APRONS.
- ② 30% SHRINKAGE FACTOR ADDED

② ①
 ② ①
 ① ①

MISSISSIPPI DEPARTMENT OF TRANSPORTATION
SUMMARY OF QUANTITIES

PROJ NO: HSIP-0055-02(250)
 COUNTY: COPIAH

FILENAME: SQ-1

Design Team: GUEST Checked: MM Date: 7/8/19

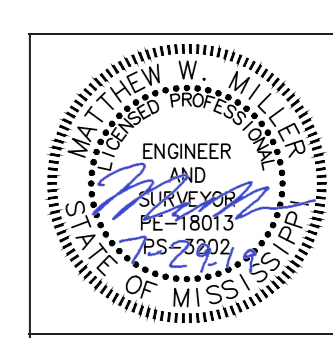

Working Number: **SQ-2**

Sheet Number: **9**

1st O.REV.

STATE	PROJECT NO.
MISS	HSIP-0055-02(250)/HSIP-0055-02(250)/HSIP-0055-02(250)

SUMMARY OF QUANTITIES (SHEET 3)

PAY ITEM NO.	PAY ITEM	UNIT	HOLMES : 106997-303000	
			Prelim	Final
202-B063	Removal of Concrete Paved Ditch	SY	1,423	
202-B122	Removal of Edge Drain Outlet	EA	12	
202-B165	Removal of Inlets, All Sizes	EA	7	
202-B191	Removal of Pipe, 8" And Above	LF	43	
203-EX040	Borrow Excavation, AH, LVM, Class B9	CY	1,415	
206-A001	Structure Excavation	CY	60	
211-B001	Topsoil for Slope Treatment, Contractor Furnished	CY	2,505	
216-A001	Solid Sodding	SY	35,757	
217-A001	Ditch Liner	SY	1,450	
219-A001	Watering	KGAL	721	
221-A001	Concrete Paved Ditch	CY	3,072	
225-A001	Grassing	ACRE	16	
234-A001	Temporary Silt Fence	LF	1,450	
234-D001	Inlet Siltation Guard	EA	7	
237-A002	Wattles, 20"	LF	500	
246-B001	Rockbags	EA	29	
601-B001	Class "B" Structural Concrete, Minor Structures	CY	11	
602-A001	Reinforcing Steel	LBS	858	
603-CA011	18" Reinforced Concrete Pipe, Class III	LF	18	
603-CA026	24" Reinforced Concrete Pipe, Class III	LF	30	
603-CB004	24" Reinforced Concrete End Section	EA	2	
604-B001	Gratings	LBS	1,750	
605-I001	Edge Drain Outlets/Vents	LF	28	
610-A001	Cable Barrier	LF	78,842	
610-B001	Cable Barrier Terminal Section	EA	27	
618-A001	Maintenance of Traffic	LS	1	
618-B001	Additional Construction Signs	SF	1	
620-A001	Mobilization	LS	1	
699-A001	Roadway Construction Stakes	LS	1	

- ⚠ ① QUANTITY INCLUDES 152.4 C.Y. FOR PAVED DITCH, 4.4 C.Y. FOR EDGE DRAIN OUTLET, 2,912 C.Y. FOR VEGETATIVE CONTROL PAD, 3.7 C.Y. FOR PAVED APRONS.
- ⚠ ② 30% SHRINKAGE FACTOR ADDED

② ⚠
② ⚠
① ⚠

REVISION OF FOOTNOTES	MM	By	MISSISSIPPI DEPARTMENT OF TRANSPORTATION SUMMARY OF QUANTITIES
	08/22/2019	Date	
			Working Number SQ-3
			Sheet Number 10

Design Team GUEST Checked MM Date 7/8/19

1st O.REV.

STATE	PROJECT NO.
MISS	HSIP-0055-02(250)/HSIP-0055-02(250)/HSIP-0055-02(250)

SUMMARY OF QUANTITIES (SHEET 4)

PAY ITEM NO.	PAY ITEM	UNIT	Total Amount	
			Prelim	Final
202-B063	Removal of Concrete Paved Ditch	SY	2,378	
202-B122	Removal of Edge Drain Outlet	EA	53	
202-B165	Removal of Inlets, All Sizes	EA	25	
202-B191	Removal of Pipe, 8" And Above	LF	119	
203-EX040	Borrow Excavation, AH, LVM, Class B9	CY	6,819	
206-A001	Structure Excavation	CY	147	
211-B001	Topsoil for Slope Treatment, Contractor Furnished	CY	7,000	
216-A001	Solid Sodding	SY	71,383	
217-A001	Ditch Liner	SY	6,650	
219-A001	Watering	KGAL	1,430	
221-A001	Concrete Paved Ditch	CY	6,095	
225-A001	Grassing	ACRE	41	
234-A001	Temporary Silt Fence	LF	6,650	
234-D001	Inlet Siltation Guard	EA	26	
237-A002	Wattles, 20"	LF	1,500	
246-B001	Rockbags	EA	111	
601-B001	Class "B" Structural Concrete, Minor Structures	CY	40	
602-A001	Reinforcing Steel	LBS	2,954	
603-CA011	18" Reinforced Concrete Pipe, Class III	LF	103	
603-CA026	24" Reinforced Concrete Pipe, Class III	LF	65	
603-CA040	30" Reinforced Concrete Pipe, Class III	LF	7	
603-CA066	42" Reinforced Concrete Pipe, Class III	LF	2	
603-CB004	24" Reinforced Concrete End Section	EA	7	
604-B001	Gratings	LBS	6,500	
605-I001	Edge Drain Outlets/Vents	LF	66	
610-A001	Cable Barrier	LF	157,370	
610-B001	Cable Barrier Terminal Section	EA	76	
618-A001	Maintenance of Traffic	LS	1	
618-B001	Additional Construction Signs	SF	3	
620-A001	Mobilization	LS	1	
699-A001	Roadway Construction Stakes	LS	1	

④ ⚠
④ ⚠
① ② ③ ⚠

- ⚠ ① QUANTITY INCLUDES 75 C.Y. FOR PAVED DITCH, 5.5 C.Y. FOR EDGE DRAIN OUTLET, 1,345 C.Y. FOR VEGETATIVE CONTROL PAD, 5.9 C.Y. FOR PAVED APRONS.
- ⚠ ② QUANTITY INCLUDES 14.2 C.Y. FOR PAVED DITCH, 0.7 C.Y. FOR EDGE DRAIN OUTLET, 1,563 C.Y. FOR VEGETATIVE CONTROL PAD, 4.4 C.Y. FOR PAVED APRONS.
- ⚠ ③ QUANTITY INCLUDES 152.4 C.Y. FOR PAVED DITCH, 4.4 C.Y. FOR EDGE DRAIN OUTLET, 2,912 C.Y. FOR VEGETATIVE CONTROL PAD, 3.7 C.Y. FOR PAVED APRONS.
- ⚠ ④ 30% SHRINKAGE FACTOR ADDED

⚠

MM	By	MISSISSIPPI DEPARTMENT OF TRANSPORTATION	
	Revision	SUMMARY OF QUANTITIES - PROJECT TOTALS	
REVISION OF FOOTNOTES	Date	PROJ NO: HSIP-0055-02(250)/HSIP-0055-02(250)/HSIP-0055-02(250)	Working Number
		FMS: 106997-301000/106997-302000/106997-303000	SQ-4
08/22/2019		FILENAME: SQ-1	Sheet Number
		Design Team GUEST Checked MM Date 7/8/19	11

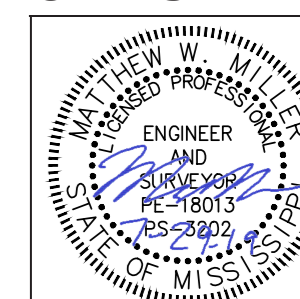

STATE	PROJECT NO.
MISS.	HSIP-0055-02(250)

ESTIMATED EARTHWORK QUANTITIES COPIAH COUNTY								
WK. SH. NUMBER	CUT	FILL	BORROW (B9)	BORROW (TOPSOIL)	UNCLASSIFIED EXCAVATION	EXCAVATION		REMARKS
						EXCESS	SURPLUS	
WK 1		1023	854	169				
WK 2		624	243	381				
WK 3		1932	1157	775				
WK 4		1506	944	562				
WK 5		939	256	683				
WK 6		974	216	758				
WK 7		81	0	81				
WK 8		8	6	0				
UNITS		CU. YDS.	CU. YDS.	CU. YDS.				
TOTALS		7087	3678	3409				30% SHRINKAGE FACTOR ADDED

ESTIMATED EARTHWORK QUANTITIES HOLMES COUNTY								
WK. SH. NUMBER	CUT	FILL	BORROW (B9)	BORROW (TOPSOIL)	UNCLASSIFIED EXCAVATION	EXCAVATION		REMARKS
						EXCESS	SURPLUS	
WK 1 A		213	0	213				
WK 2 A		181	0	181				
WK 2 A1		626	59	567				
WK 2 A2		215	117	98				
WK 2 A3		69	3	66				
WK 2 A4		9	0	9				
WK 3 A1		575	433	142				
WK 3 A2		572	425	147				
WK 3 A3		147	135	12				
WK 3 A4		60	0	60				
WK 3 A5		90	5	85				
WK 3 A6		515	61	454				
WK 4 A2		307	64	243				
WK 4 A3		341	113	228				
UNITS		CU. YDS.	CU. YDS.	CU. YDS.				
TOTALS		3920	1415	2505				30% SHRINKAGE FACTOR ADDED

ESTIMATED EARTHWORK QUANTITIES CARROLL COUNTY								
WK. SH. NUMBER	CUT	FILL	BORROW (B9)	BORROW (TOPSOIL)	UNCLASSIFIED EXCAVATION	EXCAVATION		REMARKS
						EXCESS	SURPLUS	
WK 4 A3		188	74	114				
WK 4 A4		256	68	188				
WK 4 A5		220	130	90				
WK 5 A1		440	127	313				
WK 5 A2		373	203	170				
WK 5 A3		445	234	211				
WK 5 A4		890	890	0				
UNITS		CU. YDS.	CU. YDS.	CU. YDS.				
TOTALS		2812	1726	1086				30% SHRINKAGE FACTOR ADDED

PLAN DIVISION
MISSISSIPPI DEPARTMENT OF TRANSPORTATION

7/29/2019 4:37 PM EQ-1.dgn

MISSISSIPPI DEPARTMENT OF TRANSPORTATION	
ESTIMATED QUANTITIES	
EARTHWORK	
PROJ. NO.: HSIP-0055-02(250)	
COUNTY: COPIAH, HOLMES, CARROLL	
FILENAME: EQ-1.dgn	WORKING NUMBER
DESIGN TEAM: GUEST	EQ-1
CHECKED: MM	SHEET NUMBER
DATE: 7/8/19	12

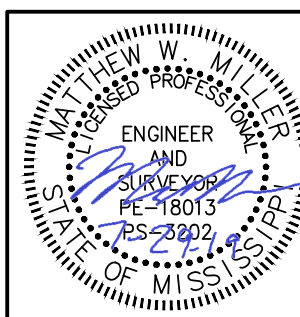

STATE	PROJECT NO.
MISS.	HSIP-0055-02(250)

ESTIMATED EROSION CONTROL ITEMS COPIAH COUNTY

WK. SH. NO.	DITCH LINER	CONCRETE PAVED DITCH	SOLID SOD	SEDIMENT CONTROL STONE	300* RIP RAP	GEOTEXTILE	EROSION CHECKS	SILT FENCE	REMARKS
WK 1	750	14.2	128				10	750	
		222	2666						VEG. CONTROL PAD
		0.363							EDGE DRAIN PAD
WK 2	500						8	500	
		238	2858						VEG. CONTROL PAD
WK 3	1000	0.363					10	1000	EDGE DRAIN PAD
		255	3068						VEG. CONTROL PAD
WK 4	1000						10	1000	
		194	2329						VEG. CONTROL PAD
WK 5	500						8	500	
		241	2891						VEG. CONTROL PAD
WK 6	500						8	500	
		235	2822						VEG. CONTROL PAD
WK 7	100						2	100	
		68	825						VEG. CONTROL PAD
WK 8	100						2	100	
		110	1317						VEG. CONTROL PAD
UNITS	S.Y.	C.Y.	S.Y.				EA	L.F.	
TOTALS	4,450	1,577.926	18,904				58	4,450	
	VEG. CONTROL PAD	1,563							
	EDGE DRAIN PAD	0.726							

PLAN DIVISION
COPIAH COUNTY
MISSISSIPPI DEPARTMENT OF TRANSPORTATION

7/29/2019 4:37 PM EQ-1.dgn

		MISSISSIPPI DEPARTMENT OF TRANSPORTATION	
		ESTIMATED QUANTITIES	
		EROSION CONTROL ITEMS	
		PROJ. NO.: HSIP-0055-02(250)	
		COUNTY: COPIAH	
		WORKING NUMBER	
		EQ-2	
		SHEET NUMBER	
		13	
REVISION	BY	DATE	
		FILENAME: EQ-1.dgn	
		DESIGN TEAM: GUEST CHECKED: MM DATE: 7/8/19	

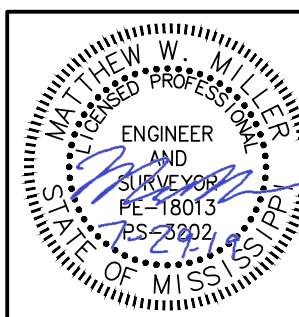

STATE	PROJECT NO.
MISS.	HSIP-0055-02(250)

ESTIMATED EROSION CONTROL ITEMS HOLMES COUNTY

WK. SH. NO.	DITCH LINER	CONCRETE PAVED DITCH	SOLID SOD	SEDIMENT CONTROL STONE	300# RIP RAP	GEOTEXTILE	EROSION CHECKS	SILT FENCE	REMARKS
WK 1A	100	0.363					2	100	EDGE DRAIN PAD
		244	2933						VEG. CONTROL PAD
WK 2A	100	10.85	49				2	100	
		0.363							EDGE DRAIN PAD
		237	2845						VEG. CONTROL PAD
WK 2A1	100	251	3022				2	100	VEG. CONTROL PAD
WK 2A2	100	40.28	180				2	100	
		0.363							EDGE DRAIN PAD
		242	2911						VEG. CONTROL PAD
WK 2A3	100	241	2898				2	100	VEG. CONTROL PAD
WK 2A4	50	33	399				1	50	VEG. CONTROL PAD
WK 3A1	100	5	22				2	100	
		0.363							EDGE DRAIN PAD
		244	2933						VEG. CONTROL PAD
WK 3A2	100	237	2849				2	100	VEG. CONTROL PAD
WK 3A3	100	0.363					2	100	EDGE DRAIN PAD
		237	2849						VEG. CONTROL PAD
WK 3A4	100	0.363					2	100	EDGE DRAIN PAD
		237	2849						VEG. CONTROL PAD
WK 3A5	100	0.363					2	100	EDGE DRAIN PAD
		135	1628						VEG. CONTROL PAD
WK 3A6	200	64	288				4	200	
		0.726							EDGE DRAIN PAD
		205	2466						VEG. CONTROL PAD
WK 4A2	100	17	101				2	100	
		0.726							EDGE DRAIN PAD
		237	2849						VEG. CONTROL PAD
WK 4A3	100	15	66				2	100	
		0.363							EDGE DRAIN PAD
		132	1,578						VEG. CONTROL PAD
UNITS	S.Y.	C.Y.	S.Y.				EA	L.F.	
TOTALS	1,450	3,068.759	35,715				29	1,450	
VEG. CONTROL PAD		2,912							
EDGE DRAIN PAD		4,356							

PLAN DIVISION
MISSISSIPPI DEPARTMENT OF TRANSPORTATION

7/29/2019 4:37 PM EQ-1.DGN

MISSISSIPPI DEPARTMENT OF TRANSPORTATION	
ESTIMATED QUANTITIES	
EROSION CONTROL ITEMS	
PROJ. NO.: HSIP-0055-02(250)	
COUNTY: HOLMES	
DATE	FILENAME: EQ-1.dgn
DESIGN TEAM	GUEST CHECKED MM DATE 7/8/19
REVISION	BY
WORKING NUMBER	EQ-3
SHEET NUMBER	14

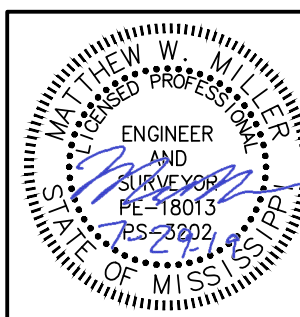

STATE	PROJECT NO.
MISS.	HSIP-0055-02(250)

ESTIMATED EROSION CONTROL ITEMS CARROLL COUNTY

WK. SH. NO.	DITCH LINER	CONCRETE PAVED DITCH	SOLID SOD	SEDIMENT CONTROL STONE	300# RIP RAP	GEOTEXTILE	EROSION CHECKS	SILT FENCE	REMARKS
WK 4A3	50	3	22				2	50	
		78	934						VEG. CONTROL PAD
WK 4A4	50	9	42				2	50	
		0.363							EDGE DRAIN PAD
		235	2822						VEG. CONTROL PAD
WK 4A5	50	29	130				2	50	
		1.089							EDGE DRAIN PAD
		172	2059						VEG. CONTROL PAD
WK 5A1	100	1.815					4	100	EDGE DRAIN PAD
		193	2311						VEG. CONTROL PAD
WK 5A2	100	34	186				4	100	
		1.089							EDGE DRAIN PAD
		242	2911						VEG. CONTROL PAD
WK 5A3	100	1.089					4	100	EDGE DRAIN PAD
		248	2980						VEG. CONTROL PAD
WK 5A4	300	186	2234				6	300	VEG. CONTROL PAD
UNITS	S.Y.	C.Y.	S.Y.				EA	L.F.	
TOTALS	750	1,434.445	16,631				24	750	
									VEG. CONTROL PAD
									EDGE DRAIN PAD
		5.445							

ROADWAY PLAN DIVISION MISSISSIPPI DEPARTMENT OF TRANSPORTATION

7/29/2019 4:37 PM EQ-1.dgn

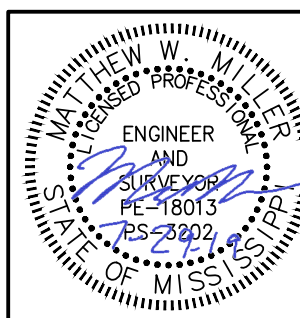
MISSISSIPPI DEPARTMENT OF TRANSPORTATION ESTIMATED QUANTITIES		
EROSION CONTROL ITEMS		
PROJ. NO.: HSIP-0055-02(250) COUNTY: CARROLL		WORKING NUMBER EQ-4
DATE	FILENAME: EQ-1.dgn	SHEET NUMBER 15
DESIGN TEAM	GUEST	CHECKED MM
		DATE 7/8/19

PIPE CULVERT DRAINAGE STRUCTURES

STATE	PROJECT NO.
MISS.	HSIP-0055-02(250)

WK. SH. NO.	STATION	ID NUMBER	TYPE	PIPE					CULVERTS					END SECTIONS					SIZE			OPENINGS	DRAWINGS REQ'D.	CLASS "B" CONC.	REINF. STEEL	GRATING	CASTING	PAVED APRON	STRUCTURE EXCAVATION		GEO TEXTILE	FILTER MATERIAL		COVER	REMARKS				
				18"	24"	30"	36"	42"	48"	18"	24"	30"	36"	48"	L	W	H	CU YDS EXCAV	EST. DEPTH	"A"	"B"																		
														L	W	H																							
COPIAH COUNTY																																							
3	432+65.340		MI-1					2																									8.35	S.Y.	SOD	REQ'D			
4	569+08.640				4																1																		
4	599+19.780		MI-2	8																															8.35	S.Y.	SOD	REQ'D	
4	605+00.00		MI-2	8																															8.35	S.Y.	SOD	REQ'D	
5	626+97.590		MI-2	8																															8.35	S.Y.	SOD	REQ'D	
5	634+56.740				10																																		
5	657+96.080		MI-1	2																																8.35	S.Y.	SOD	REQ'D
6	679+83.430		MI-2	8																																8.35	S.Y.	SOD	REQ'D
6	714+74.960				2																																		
7	1009+33.130				5																																		
7	1025+24.370		MI-1																																				
7	1062+35.254		MI-2	8																																8.35	S.Y.	SOD	REQ'D
8	1101+95.530				12																																		
UNIT CONCRETE THIS SHEET				L.F.	L.F.	L.F.	L.F.	L.F.	EA.					EA.	EA.	EA.	EA.										C.Y.	LB.	LB.	LB.	C.Y.	C.Y.							
				40	35			2	5																		14.17	1,069	2,000		4.927	63							

COPIAH PLAN DIVISION MISSISSIPPI DEPARTMENT OF TRANSPORTATION

7/29/2019 4:37 PM EQ-1.DGN

NOTE: INLET QUANTITIES ARE BASED ON CONCRETE PIPE BEING USED. NO ADJUSTMENT WILL BE MADE FOR ANY OTHER ALTERNATE PIPE USED.

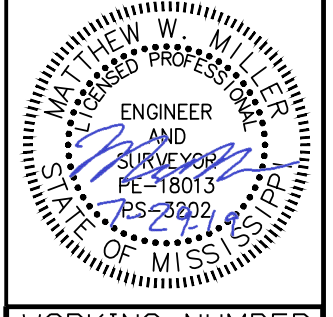
MISSISSIPPI DEPARTMENT OF TRANSPORTATION		
DRAINAGE STRUCTURES		
PROJ. NO.: HSIP-0055-02(250)		
COUNTY: COPIAH		
DATE	REVISION	BY
		
FILENAME: EQ-1.dgn		WORKING NUMBER
DESIGN TEAM GUEST CHECKED MM DATE 7/8/19		EQ-5
		SHEET NUMBER
		16

WK. SH. NO.	STATION	ID NUMBER	TYPE	PIPE												CULVERT					DRAINAGE					STRUCTURES				STATE		PROJECT NO.			
				PIPE						CULVERTS						END SECTIONS					SIZE			DRAWINGS REQ'D.	CLASS "B" CONC.	REINF. STEEL	GRATING	CASTING	PAVED APRON	STRUCTURE EXCAVATION		FILTER MATERIAL		COVER	REMARKS
				18"	24"	30"	36"	42"	48"	18"	24"	30"	36"	48"	L	W	H	OPENINGS	CU YDS EXCAV	EST. DEPTH	GEOTEXTILE	TYPE "A"	TYPE "B"												

HOLMES COUNTY

14	229+96.730				4										1						PC-1,FE-1	0.493																
18	84+25.730		MI-2	8																	7.3	3.0	3.0	2@18"	TS-1,MI-2	1.74	152	250				0.532	4.9	4				8.35 S.Y. SOD REQ'D
19	159+86.670		MI-1		16																3.0	3.67	3.9	1@24"	MI-1	0.85	59	250				0.532	4	5				
19	160+02.67		JB-1																		4.3	2.5	3.75	2@24"	JB-1	1.16	140						4	5				
20	230+55.110		MI-1		16																3.0	3.67	3.0	1@18"	MI-1	0.67	48	250				0.532	2.7	4				8.35 S.Y. SOD REQ'D
20	230+71.110		JB-1																		4.0	2.5	3.0	2@18"	JB-1	0.99	110						3	4				
22	15+28.665		MI-1		2.5																3.0	3.67	4.0	2@24"	MI-1,FE-1	0.85	59	250				0.532	3.5	5				8.35 S.Y. SOD REQ'D
22	22+28.062		MI-1		3																3.0	3.67	5.6	2@24"	MI-1,FE-1	1.17	74	250				0.532	4.8	7				
22	35+87.978				4										1										PC-1,FE-1	0.493												
24	112+72.829		MI-1		2																3.0	3.67	4.6	1@18"	MI-1	1.01	64	250				0.532	4.1	6				8.35 S.Y. SOD REQ'D
25	129+22.714		MI-2		8																7.3	3.0	3.0	2@18"	TS-2,MI-2	1.74	152	250				0.532	4.9	4				8.35 S.Y. SOD REQ'D

UNIT				L.F.	L.F.	L.F.	L.F.				EA.	EA.	EA.	EA.	EA.						C.Y.	LB.	LB.		C.Y.	C.Y.										
CONCRETE		THIS SHEET		34	29.5						2										11.17	858	1,750		3.724	35.9										

7/29/2019 4:37 PM EQ-1.dgn

NOTE: INLET QUANTITIES ARE BASED ON CONCRETE PIPE BEING USED. NO ADJUSTMENT WILL BE MADE FOR ANY OTHER ALTERNATE PIPE USED.

MISSISSIPPI DEPARTMENT OF TRANSPORTATION			
DRAINAGE STRUCTURES			
PROJ. NO.: HSIP-0055-02(250)			
COUNTY: HOLMES			
DATE	DESIGN TEAM	CHECKED	DATE
	GUEST	MM	7/8/19

REVISION	BY

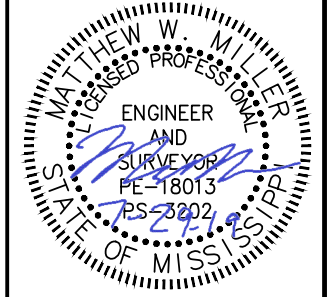

WORKING NUMBER
EQ-6

SHEET NUMBER
17

PIPE CULVERT DRAINAGE STRUCTURES

STATE PROJECT NO.
MISS. HSIP-0055-02(250)

WK. SH. NO.	STATION	ID NUMBER	TYPE	PIPE								CULVERTS					END SECTIONS					SIZE			DRAWINGS REQ'D.	CLASS "B" CONC.	REINF. STEEL	GRATING	CASTING	PAVED APRON	STRUCTURE EXCAVATION		GEO TEXTILE	FILTER MATERIAL		COVER	REMARKS
				18"	24"	30"	36"	42"	48"							18"	24"	30"	36"	48"	L	W	H	CU YDS EXCAV							EST. DEPTH	Type		Type			

CARROLL COUNTY

25	185+00.00		MI-1	10																3.0	3.67	3.0	1@18"	MI-1	0.67	48	250		0.532	2.7	4				8.35 S.Y. SOD REQ'D
25	185+00.00		JB-1																	3.67	2.50	3.0	2@18"	JB-1	0.67	48				2.4	4				
26	211+69.679		MI-1	3.5																3.0	3.67	3.0	1@18"	MI-1	0.67	48	250		0.532	2.7	4				8.35 S.Y. SOD REQ'D
26	211+69.679		JB-1																	3.67	2.50	3.0	2@18"	JB-1	0.67	48				2.4	4				
26	216+42.086		MI-1																	3.0	3.67	5.0	1@18"	MI-1	1.09	68	250		0.532	4.1	6				8.35 S.Y. SOD REQ'D
26	254+39.528		MI-1																	3.0	3.67	4.75	1@18"	MI-1	1.04	66	250		0.532	4.1	6				8.35 S.Y. SOD REQ'D
27	270+37.342		MI-1			7														3.0	7.33	5.5	2@30"	MI-1A	2.92	212	250		0.532	8.6	7				8.35 S.Y. SOD REQ'D
28	5+71.379		MI-1	8.5																3.0	3.67	4.75	1@18"	MI-1	1.04	66	250		0.532	4.1	6				8.35 S.Y. SOD REQ'D
28	33+21.075		MI-1																	3.0	3.67	4.75	1@18"	MI-1	1.04	66	250		0.532	4.1	6				8.35 S.Y. SOD REQ'D
28	59+62.689		MI-2	8																7.3	3.0	3.0	1@18"	TS-2,MI-2	1.74	152	250		0.532	4.9	4				8.35 S.Y. SOD REQ'D
29	100+21.729		MI-1	2.5																3.0	3.67	3.2	2@18"	MI-1	0.71	51	250		0.532	3.1	4.5				8.35 S.Y. SOD REQ'D
30	161+11.937		MI-1																	3.0	3.67	3.8	1@18"	MI-1	0.84	56	250		0.532	3.5	5				8.35 S.Y. SOD REQ'D
30	186+10.635		MI-1	2.5																3.0	3.67	3.0	1@18"	MI-1,TS-2	0.67	48	250		0.532	2.7	4				8.35 S.Y. SOD REQ'D
30	186+10.635		JB-1																	3.67	2.50	3.0	2@18"	JB-1	0.67	48				2.4	4				

UNIT CONCRETE	THIS SHEET	L.F.	L.F.	L.F.	L.F.	EA.	EA.	EA.	EA.	EA.	C.Y.	LB.	LB.	C.Y.	C.Y.													
		45		7							14.44	1,027	2,750	5.852	51.8													

NOTE: INLET QUANTITIES ARE BASED ON CONCRETE PIPE BEING USED. NO ADJUSTMENT WILL BE MADE FOR ANY OTHER ALTERNATE PIPE USED.

MISSISSIPPI DEPARTMENT OF TRANSPORTATION	
DRAINAGE STRUCTURES	
PROJ. NO.: HSIP-0055-02(250)	
COUNTY: CARROLL	
REVISION	<div data-bbox="2963 1689 3114 1838" data-label="Image"> </div>
DATE	WORKING NUMBER
EQ-1.dgn	EQ-7
DESIGN TEAM: GUEST	DATE: 7/8/19
	18

STATE	PROJECT NO.
MISS.	HSIP-0055-02(250)

LEGEND

 SLOPE WORK REQ'D (6:1)

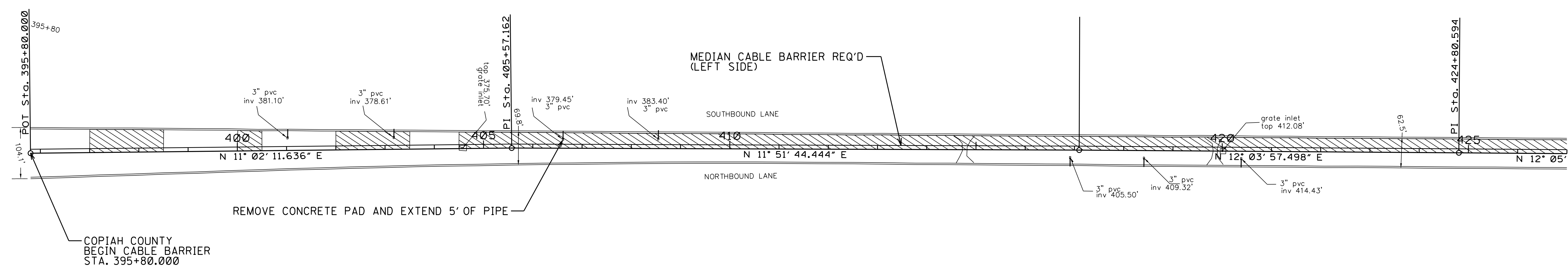
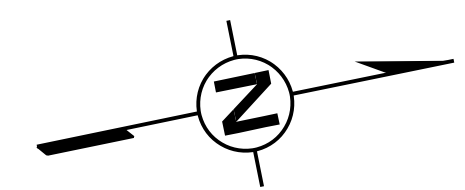

REMOVE EXISTING MEDIAN INLET
 REMOVE AND REPLACE CONCRETE APRON
 TYPE I MEDIAN INLET REQ'D
 TOP OF PROPOSED MI: 420.52
 INV: 415.17 (MATCH EXISTING)
 REMOVE 2 L.F. OF 36" RCP
 2 L.F. OF 42" RCP REQ'D
 CONNECT TO EXISTING PIPE

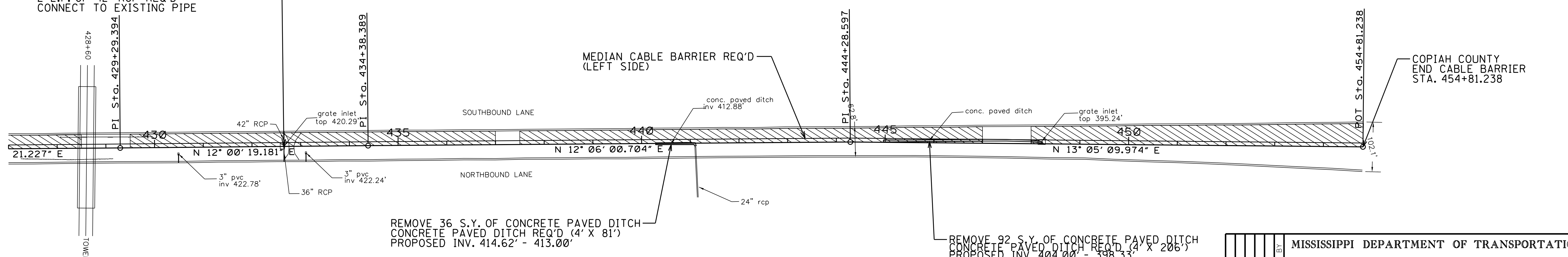

EARTHWORK TOTAL THIS SHEET		
Cut		Cu.Yds
Fill	1023	Cu.Yds
Excess		Cu.Yds
Surplus		Cu.Yds
Borrow()		Cu.Yds

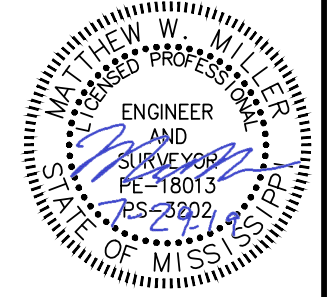
MISSISSIPPI DEPARTMENT OF TRANSPORTATION	
COPIAH COUNTY SECTION 1 PLAN VIEW	
	
PROJ. NO.: HSIP-0055-02(250) COUNTY: COPIAH	
WORKING NUMBER 3	SHEET NUMBER 19
FILENAME: wk1.dgn DESIGN TEAM: GUEST CHECKED: MM DATE: 7/8/19	

7/29/2019 4:37 PM WK1.dgn

STATE	PROJECT NO.
MISS.	HSIP-0055-02(250)

LEGEND

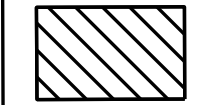
 SLOPE WORK REQ'D (6:1)

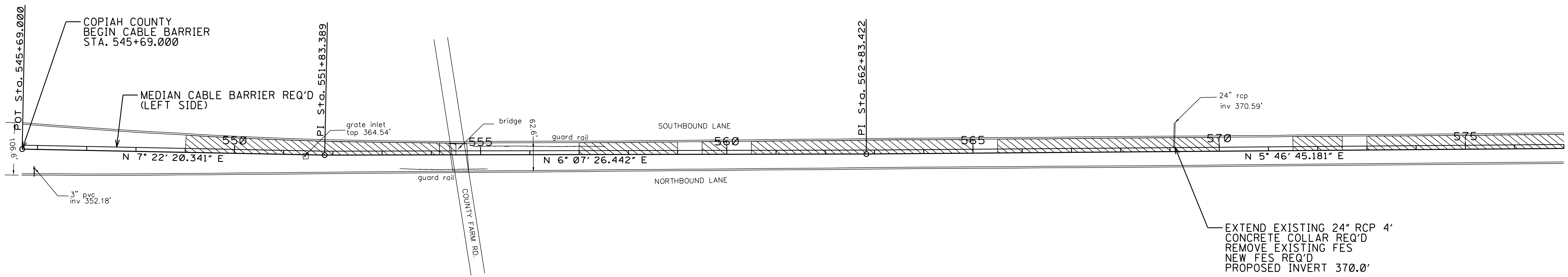
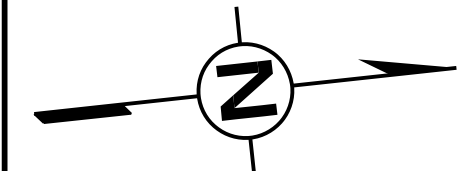

EXTEND EXISTING 24" RCP 4'
 CONCRETE COLLAR REQ'D
 REMOVE EXISTING FES
 NEW FES REQ'D
 PROPOSED INVERT 370.0'

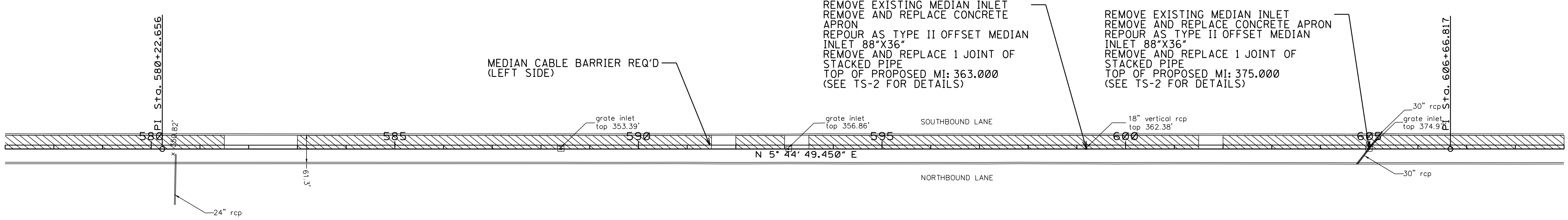

REMOVE EXISTING MEDIAN INLET
 REMOVE AND REPLACE CONCRETE
 APRON
 REPOUR AS TYPE II OFFSET MEDIAN
 INLET 88"X36"
 REMOVE AND REPLACE 1 JOINT OF
 STACKED PIPE
 TOP OF PROPOSED MI: 363.000
 (SEE TS-2 FOR DETAILS)

REMOVE EXISTING MEDIAN INLET
 REMOVE AND REPLACE CONCRETE APRON
 REPOUR AS TYPE II OFFSET MEDIAN
 INLET 88"X36"
 REMOVE AND REPLACE 1 JOINT OF
 STACKED PIPE
 TOP OF PROPOSED MI: 375.000
 (SEE TS-2 FOR DETAILS)

EARTHWORK TOTAL THIS SHEET		
Cut		Cu.Yds
Fill	624	Cu.Yds
Excess		Cu.Yds
Surplus		Cu.Yds
Borrow()		Cu.Yds

MISSISSIPPI DEPARTMENT OF TRANSPORTATION	
COPIAH COUNTY SECTION 2 PLAN VIEW	
PROJ. NO.: HSIP-0055-02(250) COUNTY: COPIAH	
DATE	FILENAME: wk2.dgn
DESIGN TEAM	GUEST
CHECKED	MM
DATE	7/8/19

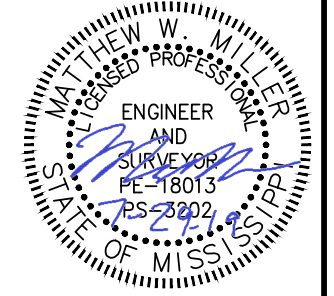

WORKING NUMBER
4

SHEET NUMBER
20

7/29/2019 4:37 PM wk2.dgn

STATE	PROJECT NO.
MISS.	HSIP-0055-02(250)

LEGEND

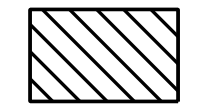
 SLOPE WORK REQ'D (6:1)

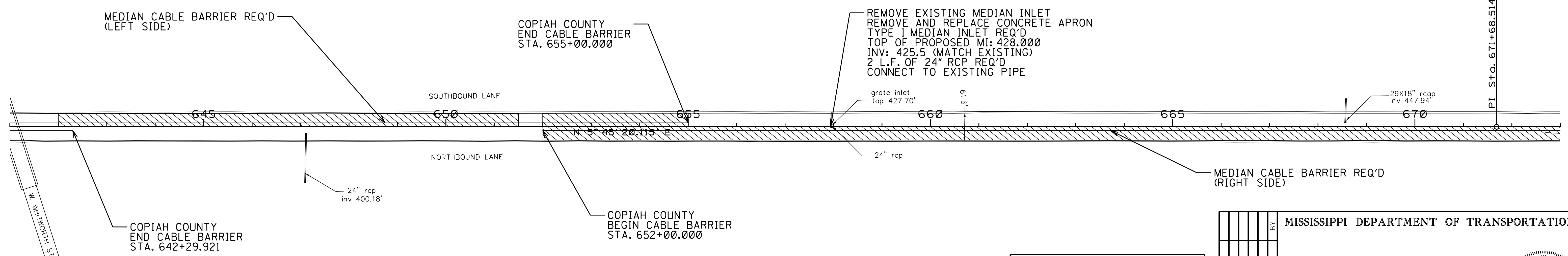
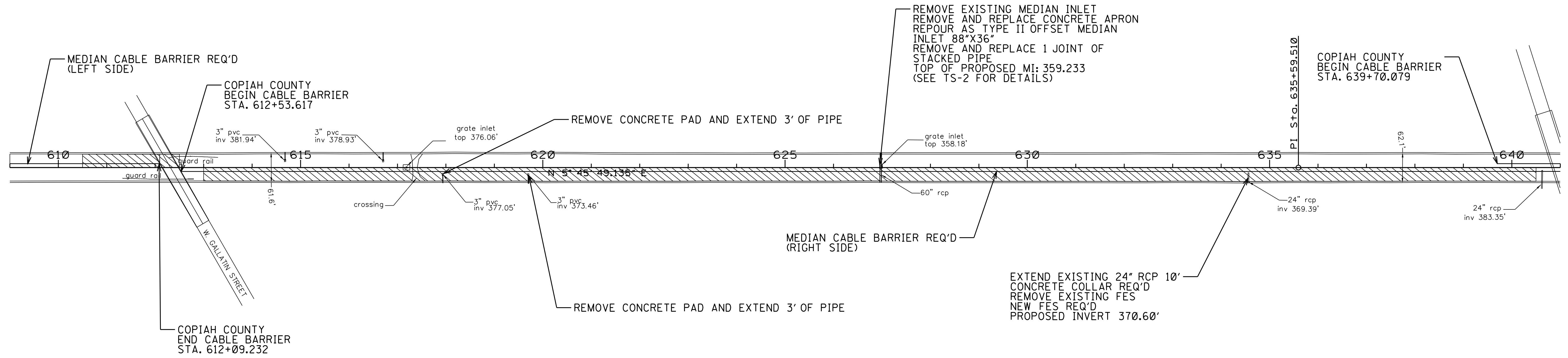
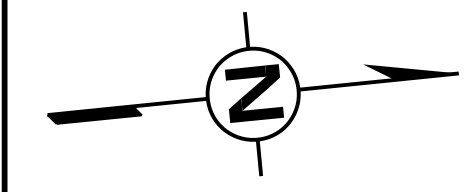

EARTHWORK TOTAL THIS SHEET		
Cut		Cu.Yds
Fill	1932	Cu.Yds
Excess		Cu.Yds
Surplus		Cu.Yds
Borrow()		Cu.Yds

MISSISSIPPI DEPARTMENT OF TRANSPORTATION	
COPIAH COUNTY SECTION 2 PLAN VIEW	
PROJ. NO.: HSIP-0055-02(250) COUNTY: COPIAH	
DATE	FILENAME: wk3.dgn
DESIGN TEAM	GUEST
CHECKED	MM
DATE	7/8/19
WORKING NUMBER	5
SHEET NUMBER	21

7/29/2019 4:37 PM WK3.dgn

STATE	PROJECT NO.
MISS.	HSIP-0055-02(250)

LEGEND

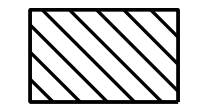
 SLOPE WORK REQ'D (6:1)

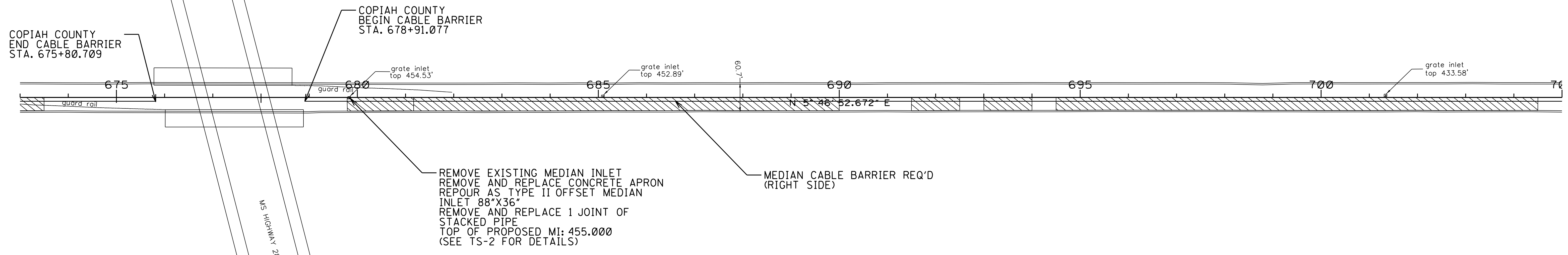
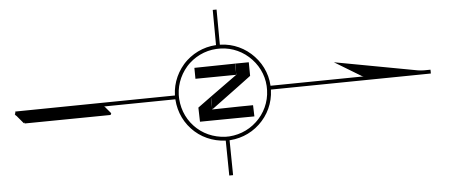

REMOVE EXISTING MEDIAN INLET
 REMOVE AND REPLACE CONCRETE APRON
 REPOUR AS TYPE II OFFSET MEDIAN
 INLET 88"X36"
 REMOVE AND REPLACE 1 JOINT OF
 STACKED PIPE
 TOP OF PROPOSED MI: 455.000
 (SEE TS-2 FOR DETAILS)

MEDIAN CABLE BARRIER REQ'D
 (RIGHT SIDE)

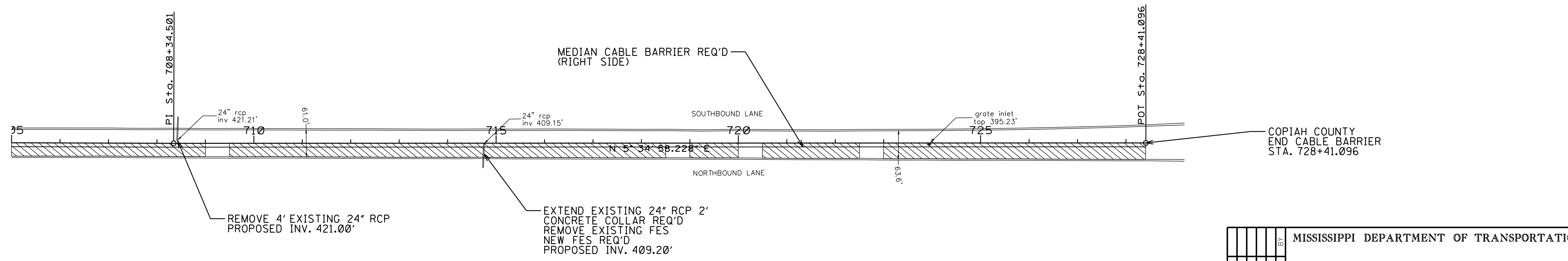

REMOVE 4' EXISTING 24" RCP
 PROPOSED INV. 421.00'

EXTEND EXISTING 24" RCP 2'
 CONCRETE COLLAR REQ'D
 REMOVE EXISTING FES
 NEW FES REQ'D
 PROPOSED INV. 409.20'

EARTHWORK TOTAL THIS SHEET		
Cut		Cu.Yds
Fill	1506	Cu.Yds
Excess		Cu.Yds
Surplus		Cu.Yds
Borrow()		Cu.Yds

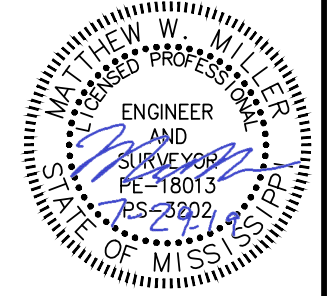
MISSISSIPPI DEPARTMENT OF TRANSPORTATION	
COPIAH COUNTY SECTION 2 PLAN VIEW	
	
PROJ. NO.: HSIP-0055-02(250) COUNTY: COPIAH	
WORKING NUMBER	6
SHEET NUMBER	22
DATE	FILENAME: wk4.dgn
DESIGN TEAM	GUEST CHECKED MM DATE 7/8/19

7/29/2019 4:37 PM wk4.dgn

STATE	PROJECT NO.
MISS.	HSIP-0055-02(250)

LEGEND

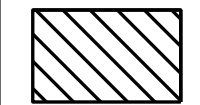
 SLOPE WORK REQ'D (6:1)

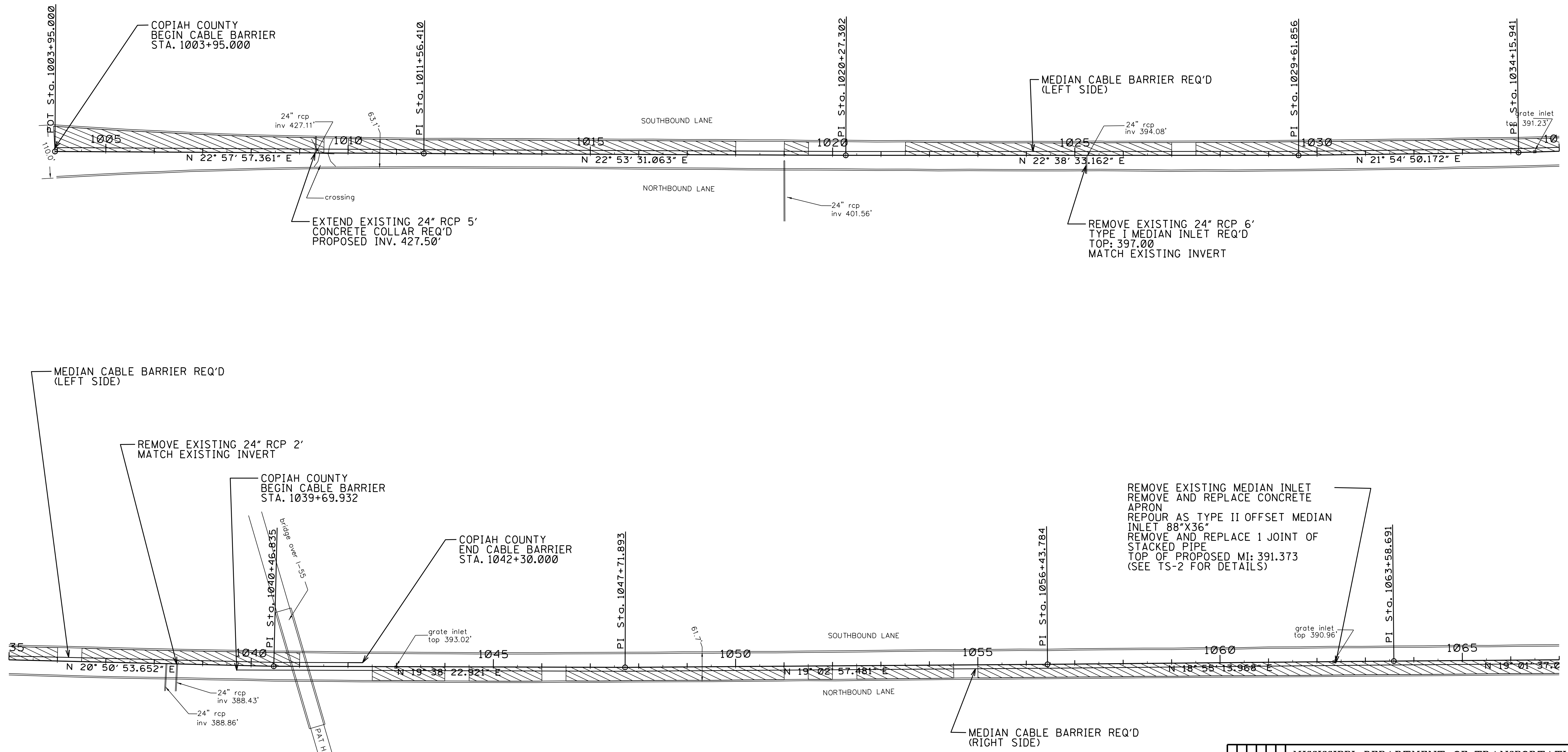
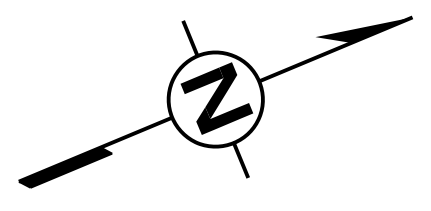

7/29/2019 4:37 PM WK5.dgn

EARTHWORK TOTAL THIS SHEET		
Cut		Cu.Yds
Fill	939	Cu.Yds
Excess		Cu.Yds
Surplus		Cu.Yds
Borrow()		Cu.Yds

MISSISSIPPI DEPARTMENT OF TRANSPORTATION	
COPIAH COUNTY SECTION 3 PLAN VIEW	
PROJ. NO.: HSIP-0055-02(250) COUNTY: COPIAH	
DATE	FILENAME: wk5.dgn
DESIGN TEAM	GUEST
CHECKED	MM
DATE	7/8/19

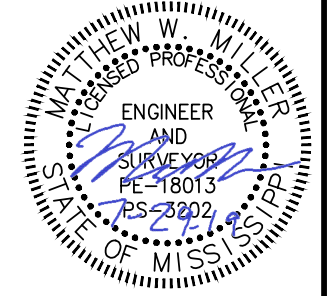

WORKING NUMBER
7

SHEET NUMBER
23

LEGEND

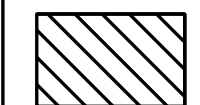

SLOPE WORK REQ'D (6:1)

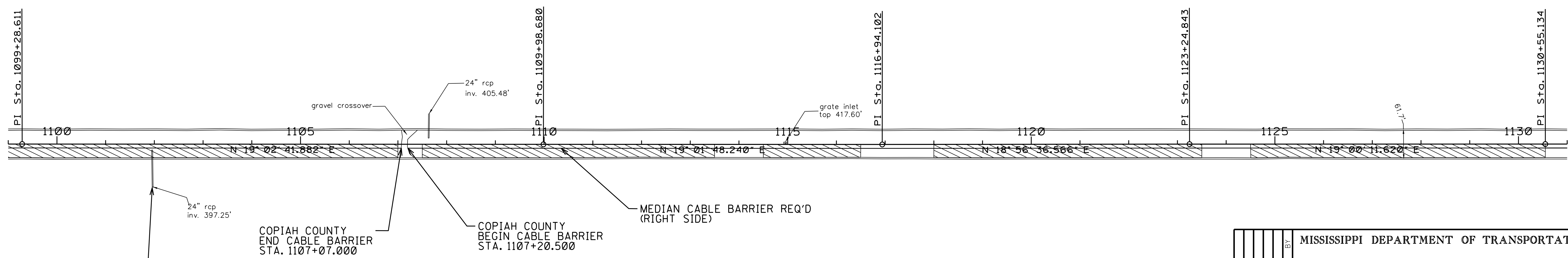
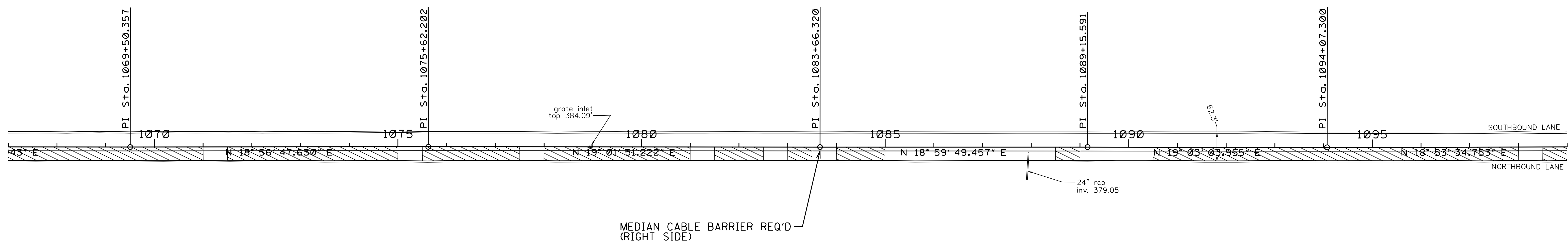
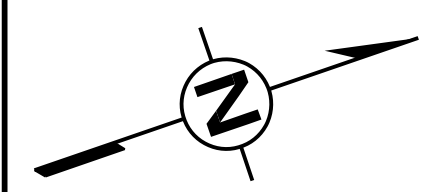

EXTEND EXISTING 24" RCP 12'
CONCRETE COLLAR REQ'D
REMOVE EXISTING FES
NEW FES REQ'D
PROPOSED INV. 398.12'

EARTHWORK TOTAL THIS SHEET		
Cut		Cu.Yds
Fill	974	Cu.Yds
Excess		Cu.Yds
Surplus		Cu.Yds
Borrow()		Cu.Yds

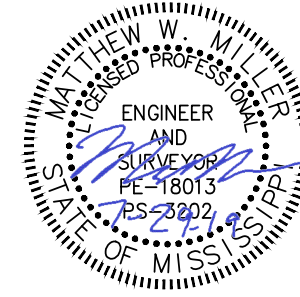
MISSISSIPPI DEPARTMENT OF TRANSPORTATION	
COPIAH COUNTY SECTION 3 PLAN VIEW	
	
PROJ. NO.: HSIP-0055-02(250) COUNTY: COPIAH	
WORKING NUMBER 8	SHEET NUMBER 24
FILENAME: wk6.dgn DESIGN TEAM: GUEST CHECKED: MM DATE: 7/8/19	

7/29/2019 4:37 PM wk6.dgn

ROADWAY PLAN DIVISION
MISSISSIPPI DEPARTMENT OF TRANSPORTATION

STATE	PROJECT NO.
MISS.	HSIP-0055-02(250)

LEGEND

 SLOPE WORK REQ'D (6:1)

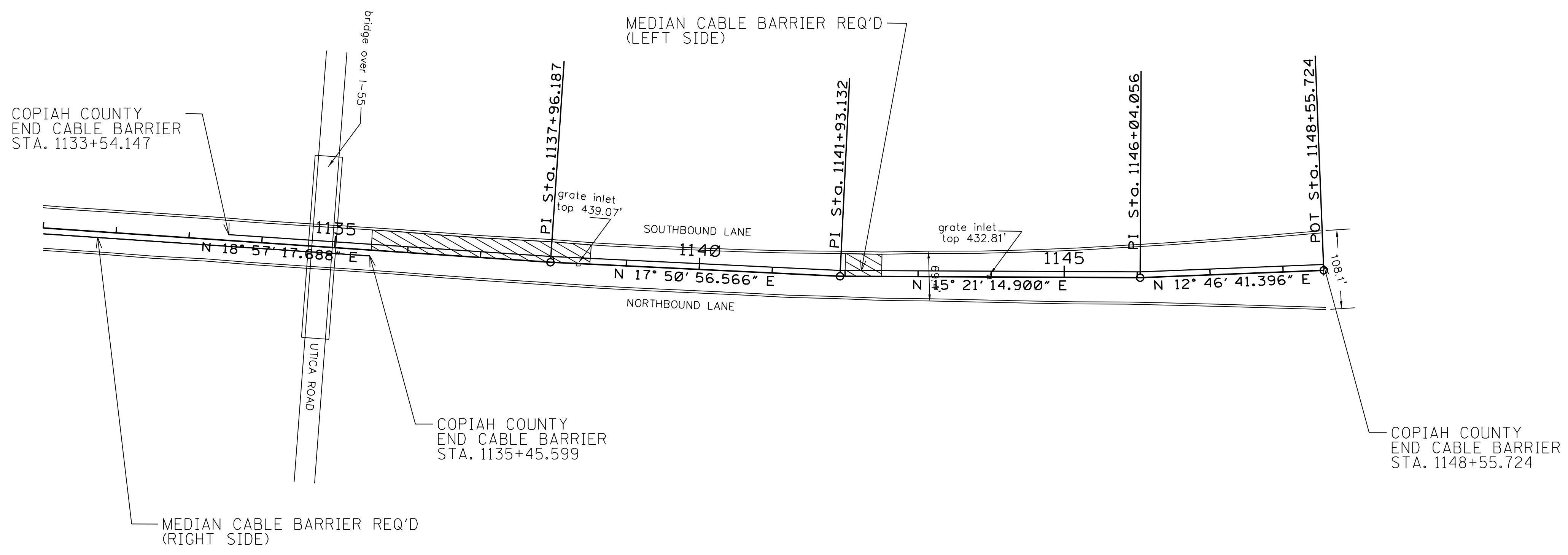
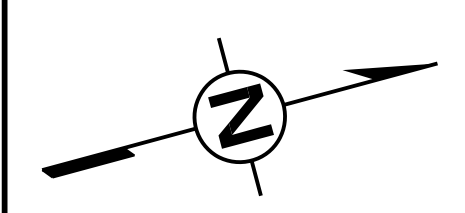

7/29/2019 4:37 PM WK7.DGN

EARTHWORK TOTAL THIS SHEET		
Cut		Cu.Yds
Fill	81	Cu.Yds
Excess		Cu.Yds
Surplus		Cu.Yds
Borrow()		Cu.Yds

MISSISSIPPI DEPARTMENT OF TRANSPORTATION	
COPIAH COUNTY SECTION 3 PLAN VIEW	
PROJ. NO.: HSIP-005-02(250) COUNTY: COPIAH	
WORKING NUMBER 9	SHEET NUMBER 25
DATE	FILENAME: wk7.dgn
DESIGN TEAM	GUEST CHECKED MM DATE 7/8/19

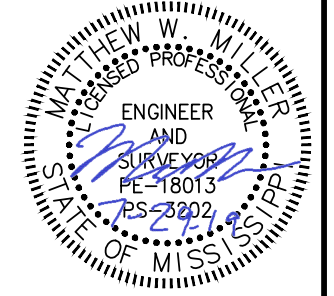

STATE	PROJECT NO.
MISS.	HSIP-0055-02(250)

LEGEND

 SLOPE WORK REQ'D (6:1)

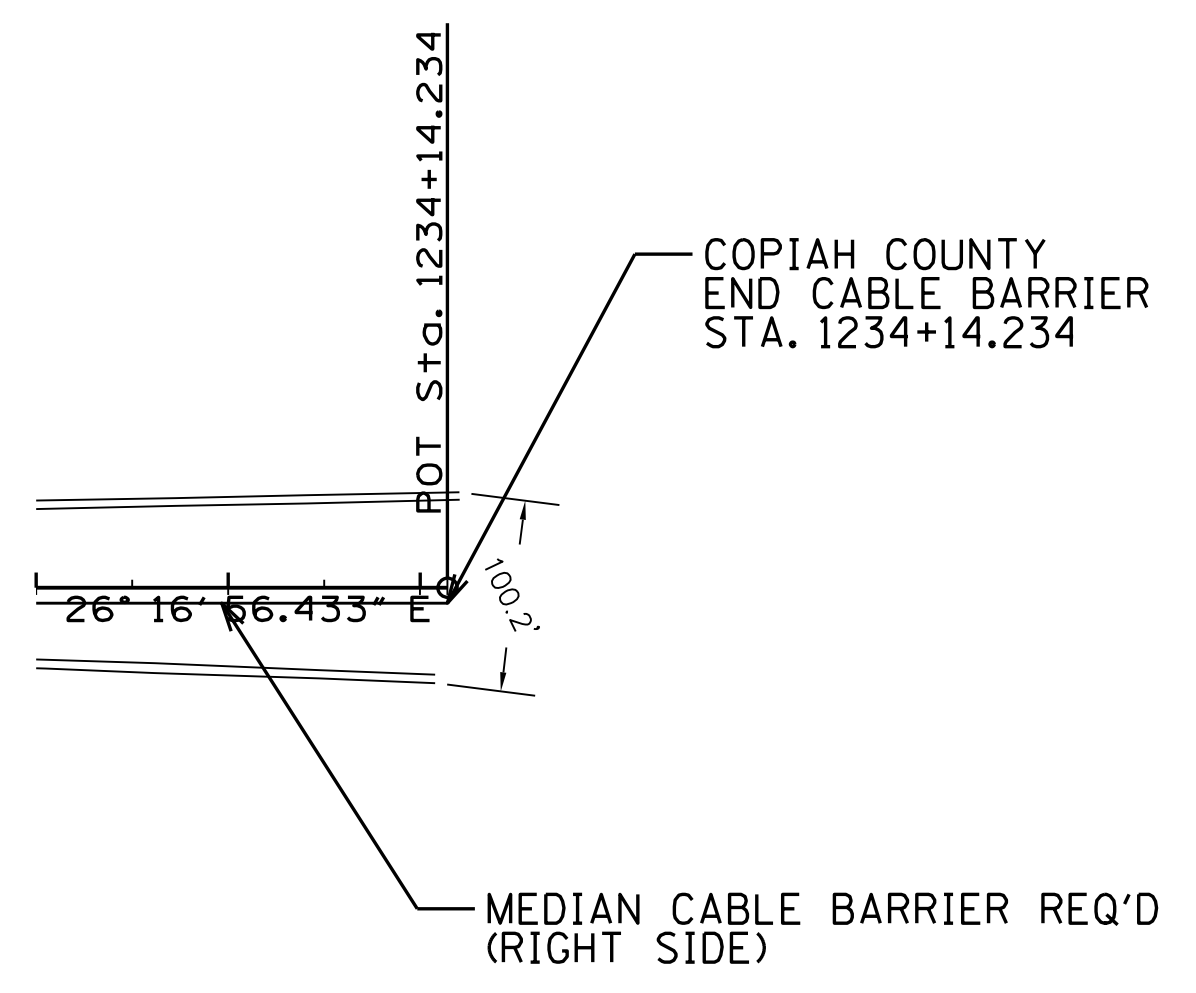
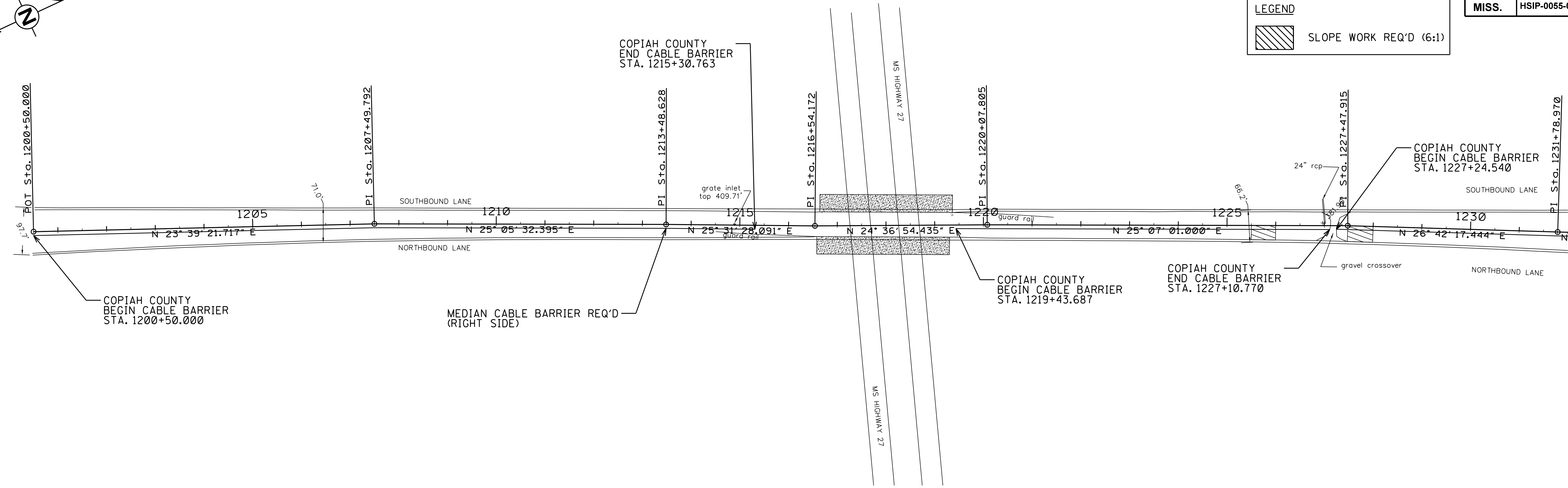
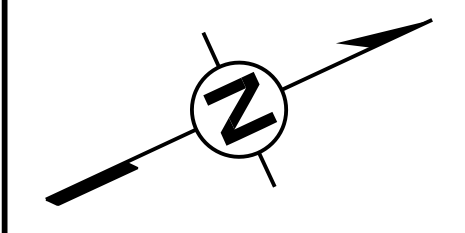

EARTHWORK TOTAL THIS SHEET

Cut		Cu.Yds
Fill	8	Cu.Yds
Excess		Cu.Yds
Surplus		Cu.Yds
Borrow()		Cu.Yds

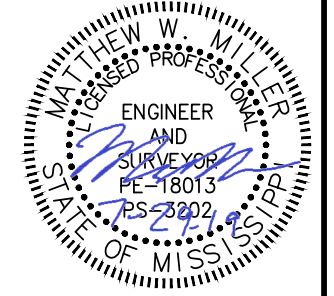
MISSISSIPPI DEPARTMENT OF TRANSPORTATION	
COPIAH COUNTY SECTION 4 PLAN VIEW	
	
PROJ. NO.: HSIP-0055-02(250) COUNTY: COPIAH	
WORKING NUMBER 10	SHEET NUMBER 26
FILENAME: wk8.dgn DESIGN TEAM: GUEST CHECKED: MM DATE: 7/8/19	

7/29/2019 4:37 PM WK8.dgn PLAN DIVISION MISSISSIPPI DEPARTMENT OF TRANSPORTATION

STATE	PROJECT NO.
MISS.	HSIP-0055-02(250)

LEGEND

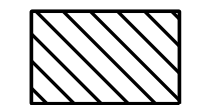
 SLOPE WORK REQ'D (6:1)

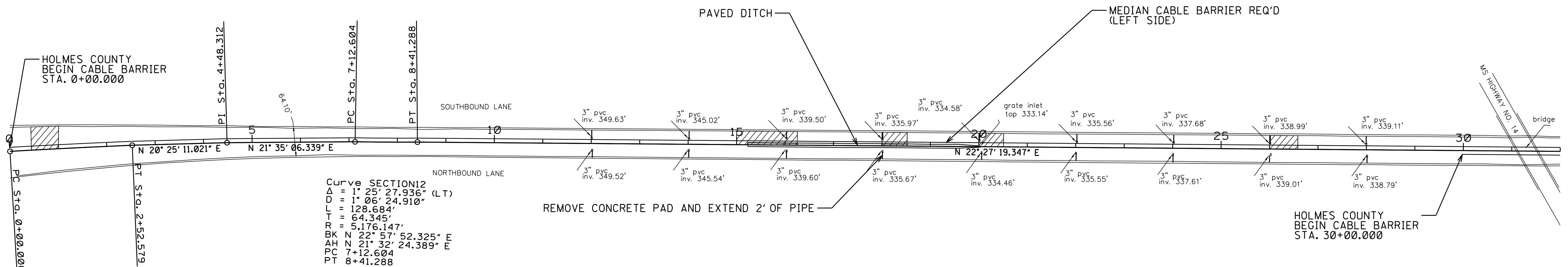
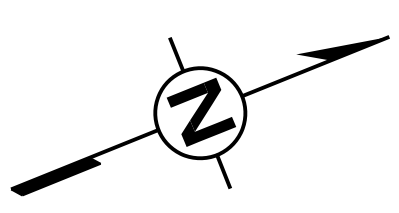

Curve SECTION12
 $\Delta = 1^\circ 25' 27.936''$ (LT)
 $D = 1^\circ 06' 24.910''$
 $L = 128.684'$
 $T = 64.345'$
 $R = 5,176.147'$
 BK N $22^\circ 57' 52.325''$ E
 AH N $21^\circ 32' 24.389''$ E
 PC 7+12.604
 PT 8+41.288

Curve SECTION11
 $\Delta = 0^\circ 55' 59.955''$ (RT)
 $D = 0^\circ 22' 10.261''$
 $L = 252.579'$
 $T = 126.292'$
 $R = 15,505.594'$
 BK N $18^\circ 40' 21.919''$ E
 AH N $19^\circ 36' 21.875''$ E
 PC 0+00.000
 PT 2+52.579

Curve SECTION14
 $\Delta = 0^\circ 31' 33.618''$ (LT)
 $D = 0^\circ 22' 54.175''$
 $L = 137.800'$
 $T = 68.901'$
 $R = 15,010.083'$
 BK N $22^\circ 45' 59.808''$ E
 AH N $22^\circ 14' 26.190''$ E
 PC 55+38.969
 PT 56+76.770

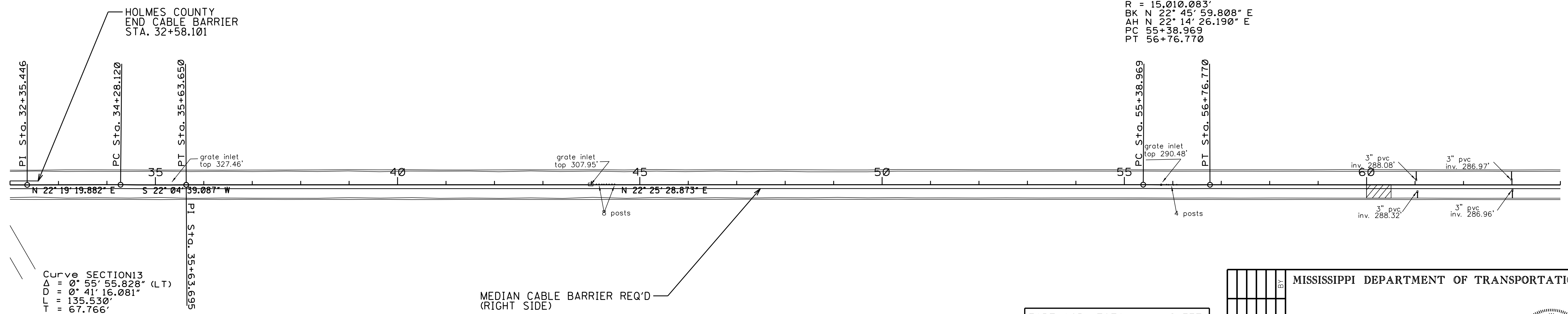

Curve SECTION13
 $\Delta = 0^\circ 55' 55.828''$ (LT)
 $D = 0^\circ 41' 16.081''$
 $L = 135.530'$
 $T = 67.766'$
 $R = 8,330.293'$
 BK N $23^\circ 00' 34.594''$ E
 AH N $22^\circ 04' 38.766''$ E
 PC 34+28.120
 PT 35+63.650

EARTHWORK TOTAL THIS SHEET		
Cut		CuYds
Fill	213	CuYds
Excess		CuYds
Surplus		CuYds
Borrow()		CuYds

MISSISSIPPI DEPARTMENT OF TRANSPORTATION	
HOLMES COUNTY SECTION 1 PLAN VIEW	
PROJ. NO.: HSIP-0055-02(250) COUNTY: HOLMES	
DATE	FILENAME: wk1a.dgn
DESIGN TEAM	GUEST
CHECKED	MM
DATE	7/8/19

WORKING NUMBER
11

SHEET NUMBER
27

7/29/2019 4:37 PM WK1A.DGN

STATE	PROJECT NO.
MISS.	HISP-0055-02(250)

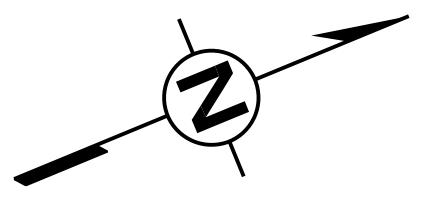

Curve SECTION15
 Δ = 2° 11' 27.189" (LT)
 D = 1° 38' 55.251"
 L = 132.887'
 T = 66.452'
 R = 3,475.250'
 BK N 23° 34' 43.814" E
 AH N 21° 23' 16.625" E
 PC 84+39.323
 PT 85+72.210

LEGEND

SLOPE WORK REQ'D (6:1)

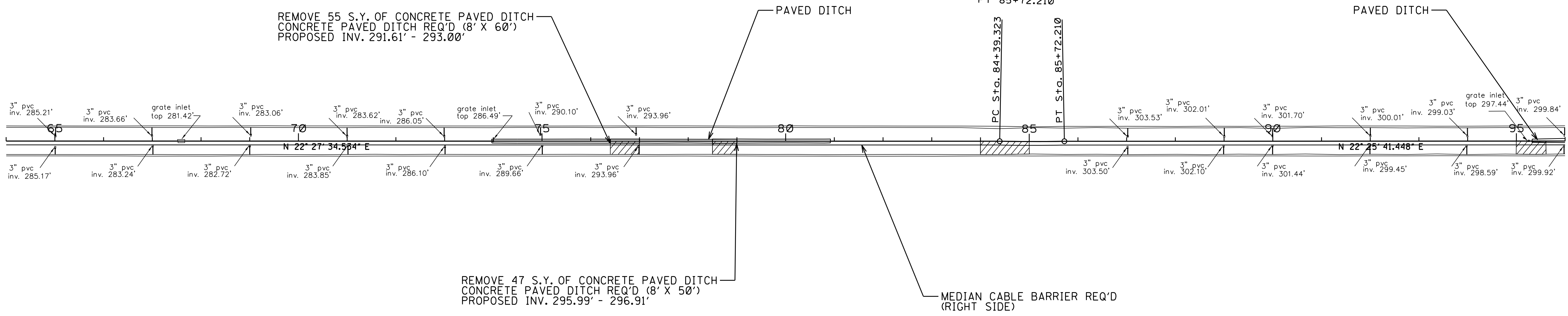

Curve SECTION16
 Δ = 0° 56' 50.532" (LT)
 D = 0° 49' 45.230"
 L = 114.247'
 T = 57.125'
 R = 6,909.511'
 BK N 23° 05' 01.973" E
 AH N 22° 08' 11.440" E
 PC 98+72.669
 PT 99+86.916

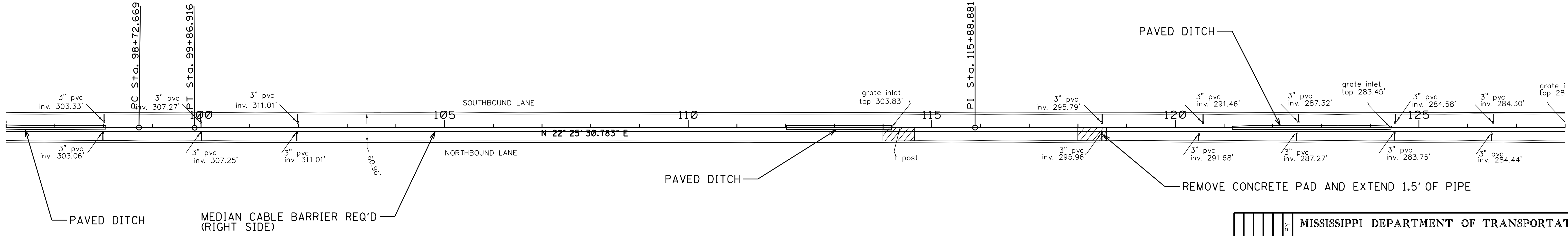

EARTHWORK TOTAL THIS SHEET	
Cut	Cu.Yds
Fill	181 Cu.Yds
Excess	Cu.Yds
Surplus	Cu.Yds
Borrow()	Cu.Yds

MISSISSIPPI DEPARTMENT OF TRANSPORTATION	
HOLMES COUNTY SECTION 1 PLAN VIEW	
PROJ. NO.: HSP-0055-02(250) COUNTY: HOLMES	
DATE	WORKING NUMBER
DESIGN TEAM	12
CHECKED	SHEET NUMBER
MM	28
DATE	
7/8/19	

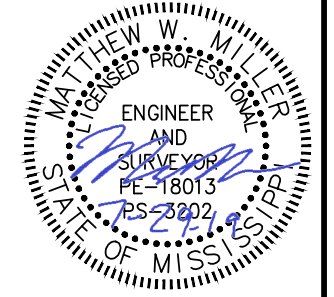

7/29/2019 4:37 PM wk2a.dgn

STATE	PROJECT NO.
MISS.	HISP-0055-02(250)

LEGEND

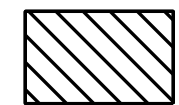
 SLOPE WORK REQ'D (6:1)

Curve SECTION17
 $\Delta = 7^\circ 09' 04.994''$ (LT)
 $D = 0^\circ 53' 01.949''$
 $L = 809.095'$
 $T = 405.074'$
 $R = 6,482.341'$
 $BK N 22^\circ 28' 12.141'' E$
 $AH N 15^\circ 19' 07.147'' E$
 $PC 151+41.487$
 $PT 159+50.582$

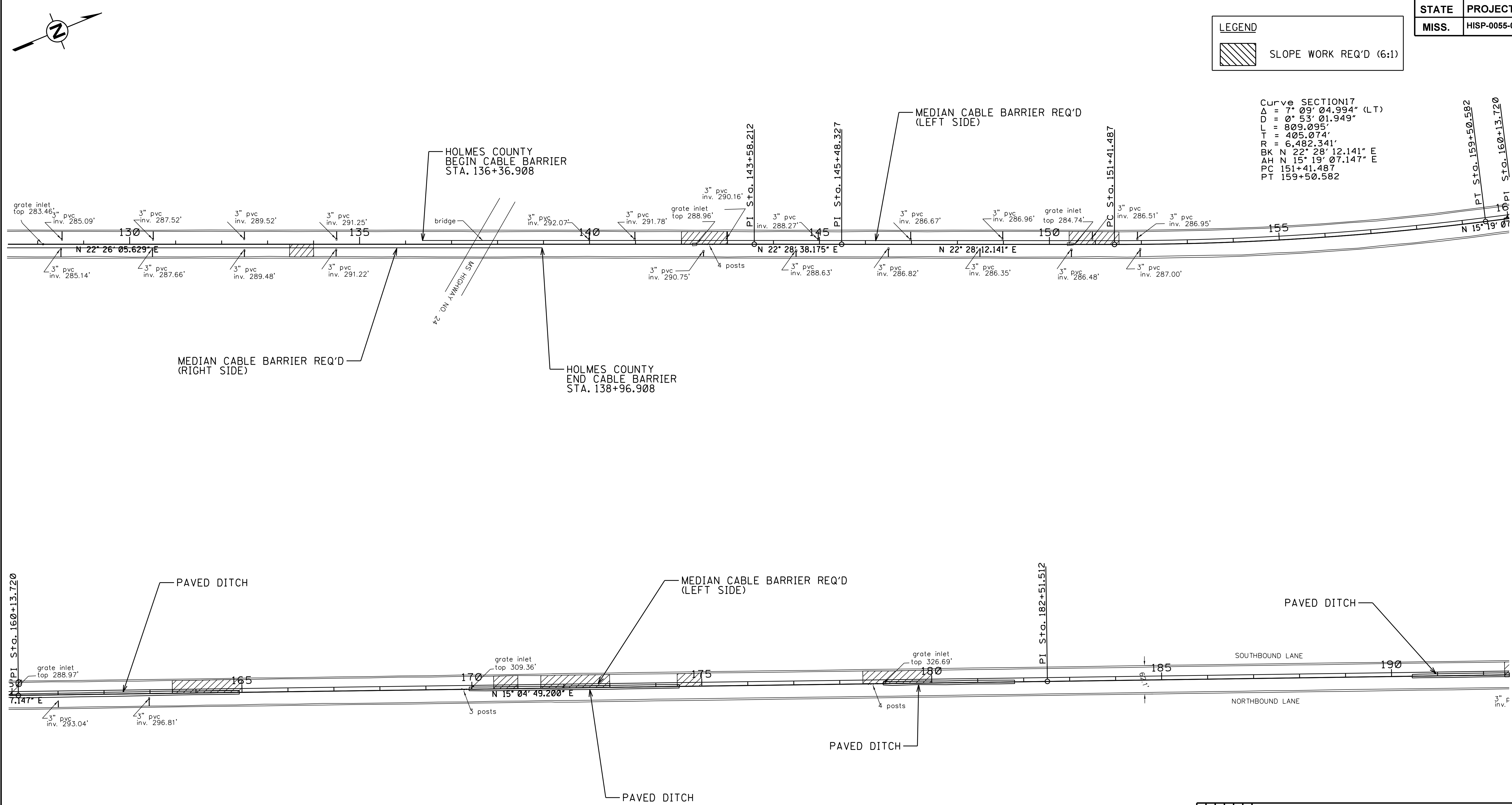

EARTHWORK TOTAL THIS SHEET		
Cut		Cu.Yds
Fill	626	Cu.Yds
Excess		Cu.Yds
Surplus		Cu.Yds
Borrow()		Cu.Yds

MISSISSIPPI DEPARTMENT OF TRANSPORTATION	
HOLMES COUNTY SECTION 1 PLAN VIEW	
PROJ. NO.: HSP-0055-02(250) COUNTY: HOLMES	
DATE	FILENAME: wk2A1.dgn
DESIGN TEAM	GUEST
CHECKED	MM
DATE	7/8/19
WORKING NUMBER	13
SHEET NUMBER	29

7/29/2019 4:37 PM wk2A1.dgn

STATE	PROJECT NO.
MISS.	HISP-0055-02(250)

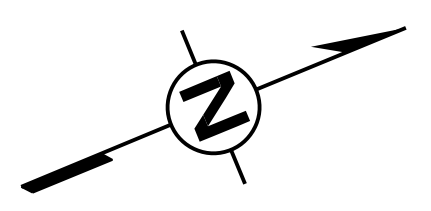

LEGEND

SLOPE WORK REQ'D (6:1)

Curve SECTION18
 Δ = 1° 13' 37.542" (LT)
 D = 0° 35' 22.031"
 L = 208.175'
 T = 104.092'
 R = 9,720.161'
 BK N 15° 37' 47.381" E
 AH N 14° 24' 09.839" E
 PC 210+36.565
 PT 212+44.740

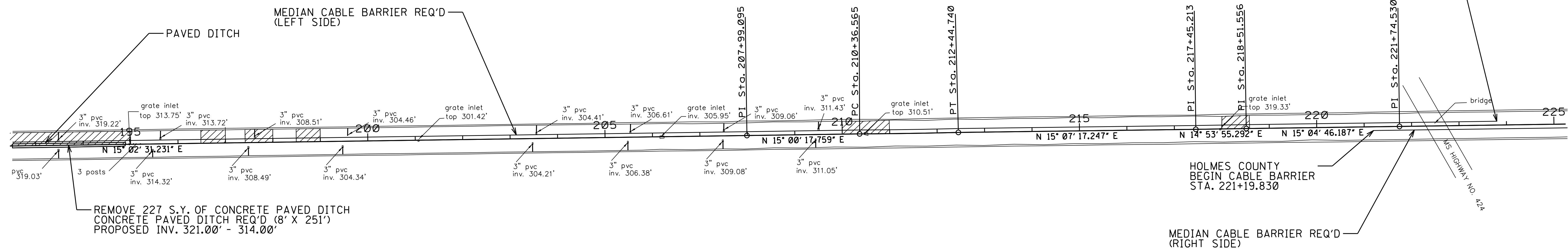

REMOVE 227 S.Y. OF CONCRETE PAVED DITCH
 CONCRETE PAVED DITCH REQ'D (8' X 251')
 PROPOSED INV. 321.00' - 314.00'

HOLMES COUNTY
 BEGIN CABLE BARRIER
 STA. 221+19.830

MEDIAN CABLE BARRIER REQ'D
 (RIGHT SIDE)

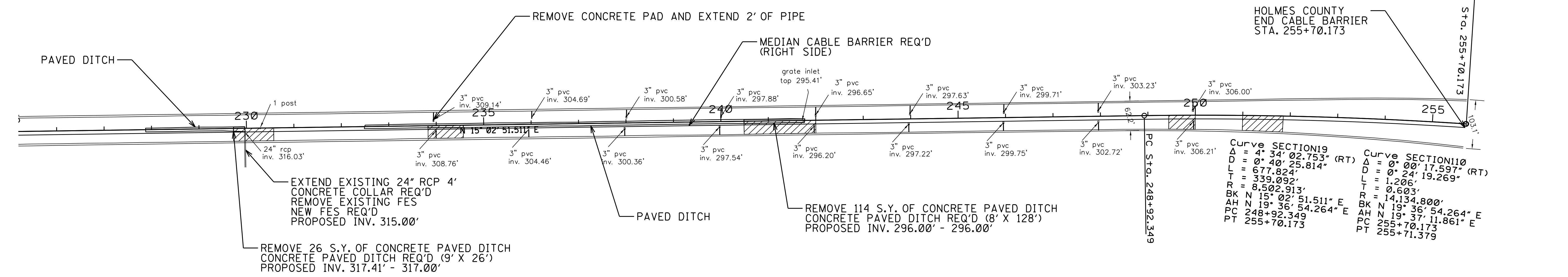

EXTEND EXISTING 24" RCP 4'
 CONCRETE COLLAR REQ'D
 REMOVE EXISTING FES
 NEW FES REQ'D
 PROPOSED INV. 315.00'

REMOVE 26 S.Y. OF CONCRETE PAVED DITCH
 CONCRETE PAVED DITCH REQ'D (9' X 26')
 PROPOSED INV. 317.41' - 317.00'

REMOVE 114 S.Y. OF CONCRETE PAVED DITCH
 CONCRETE PAVED DITCH REQ'D (8' X 128')
 PROPOSED INV. 296.00' - 296.00'

Curve SECTION19
 Δ = 4° 34' 02.753" (RT)
 D = 0° 40' 25.814"
 L = 677.824'
 T = 339.092'
 R = 8,502.913'
 BK N 15° 02' 51.511" E
 AH N 19° 36' 54.264" E
 PC 248+92.349
 PT 255+70.173

Curve SECTION110
 Δ = 0° 00' 17.597" (RT)
 D = 0° 24' 19.269"
 L = 1,206'
 T = 0.603'
 R = 14,134.800'
 BK N 19° 36' 54.264" E
 AH N 19° 37' 11.861" E
 PC 255+70.173
 PT 255+71.379

EARTHWORK TOTAL THIS SHEET	
Cut	Cu.Yds
Fill	215 Cu.Yds
Excess	Cu.Yds
Surplus	Cu.Yds
Borrow()	Cu.Yds

MISSISSIPPI DEPARTMENT OF TRANSPORTATION	
HOLMES COUNTY SECTION 1 PLAN VIEW	
PROJ. NO.: HSP-0055-02(250) COUNTY: HOLMES	
DATE	FILENAME: wk2A2.dgn
DESIGN TEAM	GUEST
CHECKED	MM
DATE	7/8/19
WORKING NUMBER	14
SHEET NUMBER	30

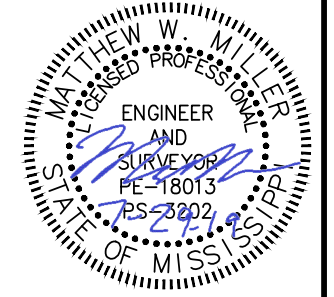

7/29/2019 4:37 PM wk2A2.dgn

LEGEND

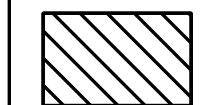
 SLOPE WORK REQ'D (6:1)

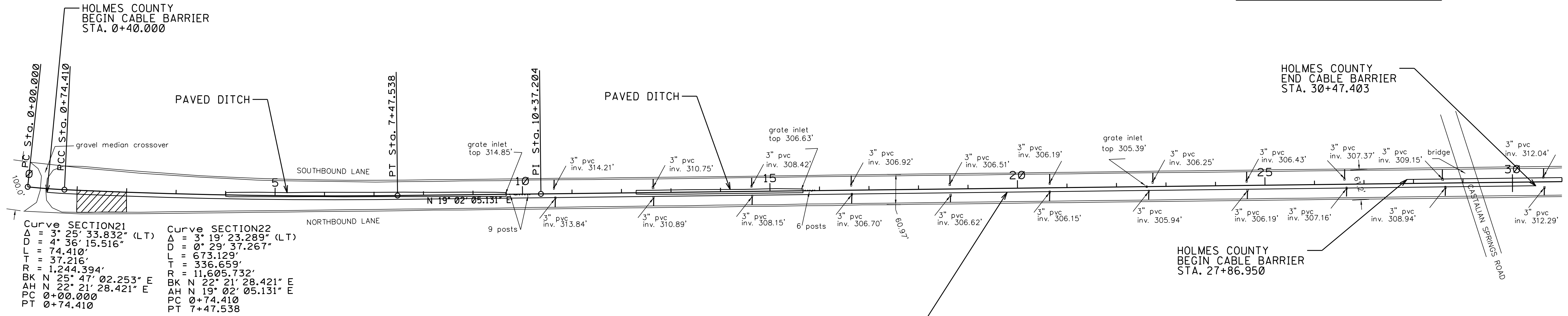
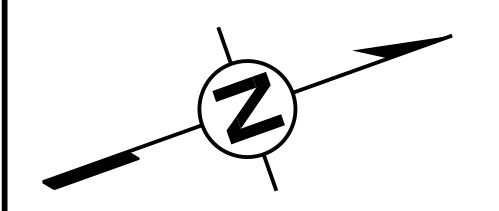

Curve SECTION21	Curve SECTION22
Δ = 3° 25' 33.832" (LT)	Δ = 3° 19' 23.289" (LT)
D = 4° 36' 15.516"	D = 0° 29' 37.267"
L = 74.410'	L = 673.129'
T = 37.216'	T = 336.659'
R = 1,244.394'	R = 11,605.732'
BK N 25° 47' 02.253" E	BK N 22° 21' 28.421" E
AH N 22° 21' 28.421" E	AH N 19° 02' 05.131" E
PC 0+00.000	PC 0+74.410
PT 0+74.410	PT 7+47.538

MEDIAN CABLE BARRIER REQ'D (RIGHT SIDE)

MEDIAN CABLE BARRIER REQ'D (LEFT SIDE)

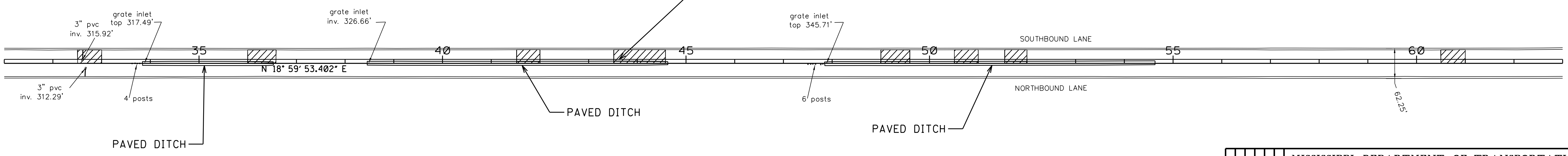

EARTHWORK TOTAL THIS SHEET		
Cut		Cu.Yds
Fill	69	Cu.Yds
Excess		Cu.Yds
Surplus		Cu.Yds
Borrow()		Cu.Yds

MISSISSIPPI DEPARTMENT OF TRANSPORTATION	
HOLMES COUNTY SECTION 2 PLAN VIEW	
PROJ. NO.: HSP-0055-02(250) COUNTY: HOLMES	
DATE	WORKING NUMBER
DESIGN TEAM	31
CHECKED	SHEET NUMBER
DATE	31

FILENAME: wk2A3.dgn

DESIGN TEAM: GUEST

CHECKED: MM

DATE: 7/8/19

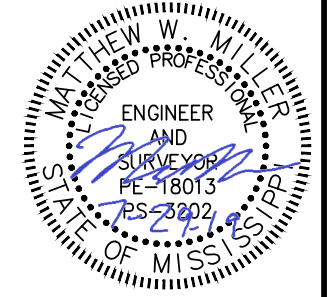

7/29/2019 4:37 PM WK2A3.DGN

STATE	PROJECT NO.
MISS.	HSIP-0055-02(250)

LEGEND

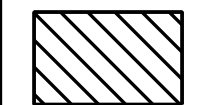
 SLOPE WORK REQ'D (6:1)

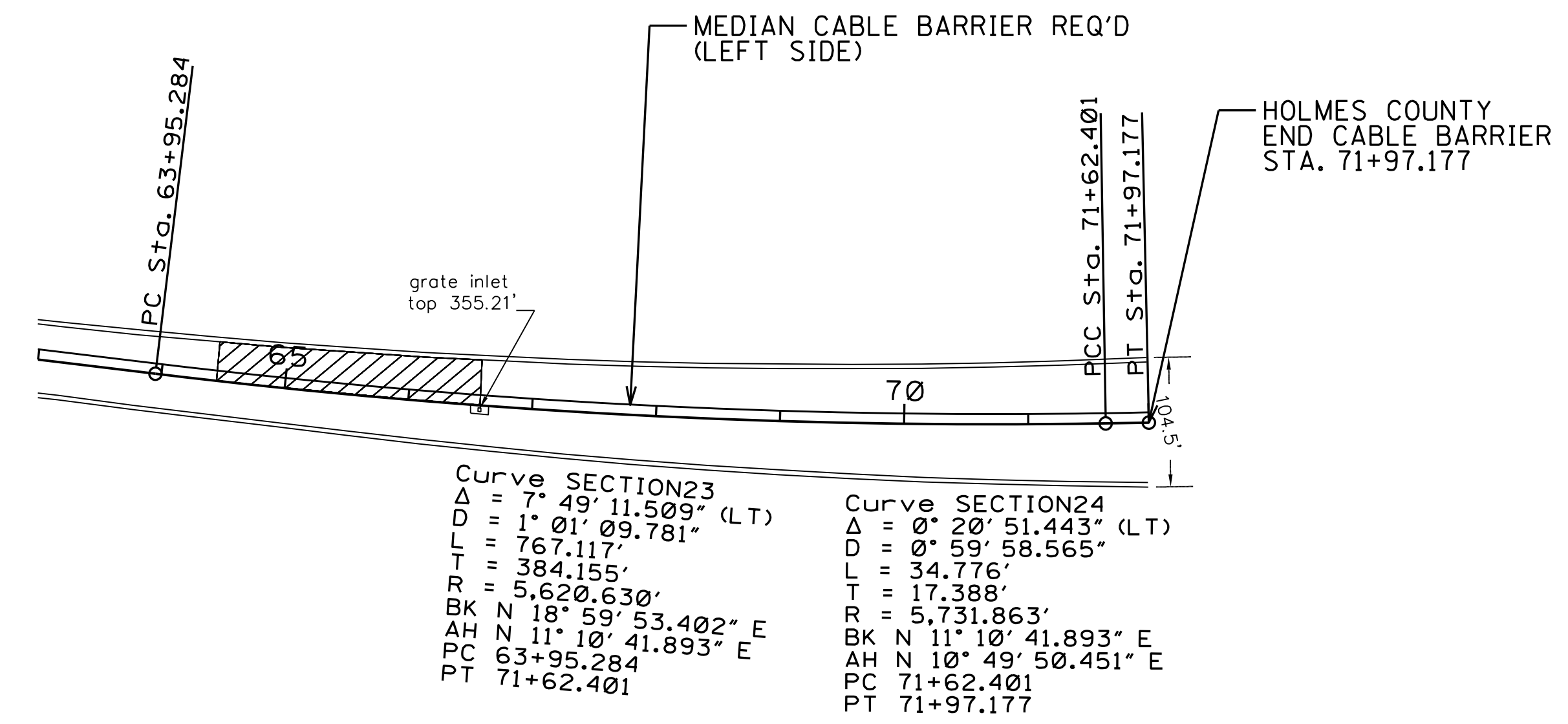
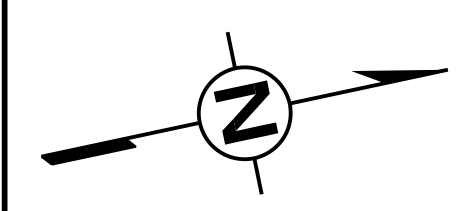

<p>Curve SECTION23 $\Delta = 7^\circ 49' 11.509''$ (LT) $D = 1^\circ 01' 09.781''$ $L = 767.117'$ $T = 384.155'$ $R = 5,620.630'$ BK N $18^\circ 59' 53.402''$ E AH N $11^\circ 10' 41.893''$ E PC 63+95.284 PT 71+62.401</p>	<p>Curve SECTION24 $\Delta = 0^\circ 20' 51.443''$ (LT) $D = 0^\circ 59' 58.565''$ $L = 34.776'$ $T = 17.388'$ $R = 5,731.863'$ BK N $11^\circ 10' 41.893''$ E AH N $10^\circ 49' 50.451''$ E PC 71+62.401 PT 71+97.177</p>
--	--

7/29/2019 4:37 PM WK2A4.DGN

EARTHWORK TOTAL THIS SHEET		
Cut		Cu.Yds
Fill	9	Cu.Yds
Excess		Cu.Yds
Surplus		Cu.Yds
Borrow()		Cu.Yds

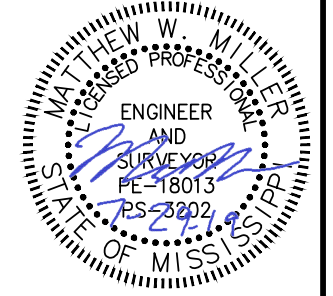
MISSISSIPPI DEPARTMENT OF TRANSPORTATION	
HOLMES COUNTY SECTION 2 PLAN VIEW	
	
PROJ. NO.: HSIP-0055-02(250)	WORKING NUMBER 16
COUNTY: HOLMES	SHEET NUMBER 32
FILENAME: wk2A4.dgn	
DESIGN TEAM: GUEST	CHECKED: MM DATE: 7/8/19

LEGEND

 SLOPE WORK REQ'D (6:1)

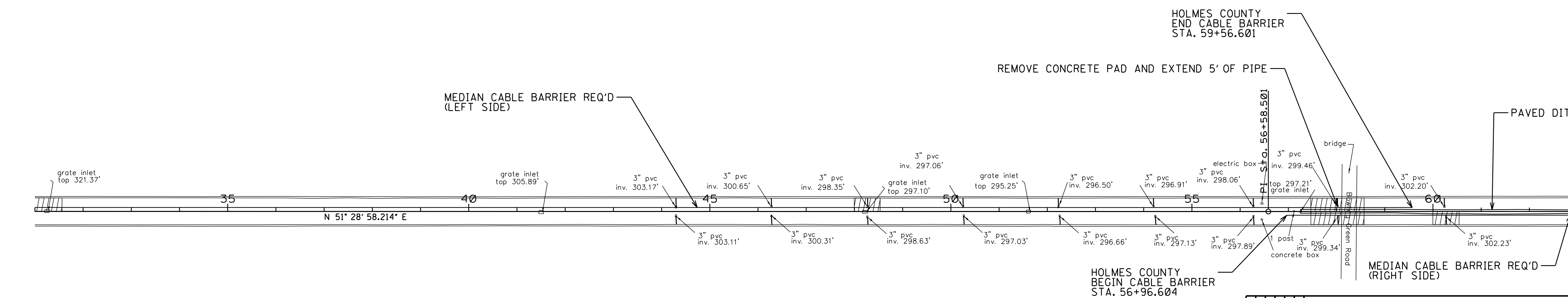
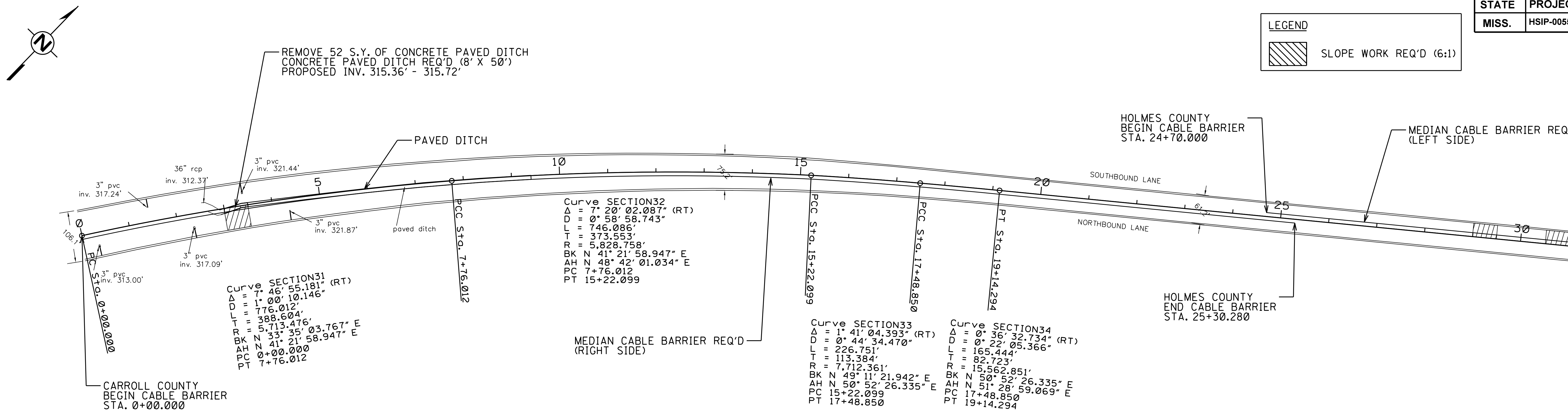

EARTHWORK TOTAL THIS SHEET		
Cut		Cu.Yds
Fill	575	Cu.Yds
Excess		Cu.Yds
Surplus		Cu.Yds
Borrow()		Cu.Yds

MISSISSIPPI DEPARTMENT OF TRANSPORTATION

HOLMES COUNTY SECTION 3 PLAN VIEW

PROJ. NO.: HSIP-0055-02(250)
COUNTY: HOLMES

ENGINEER AND SURVEYOR
W. W. WILSON
PE 18013
MS-2002

WORKING NUMBER: 17
SHEET NUMBER: 33

FILENAME: wk3A1.dgn
DESIGN TEAM: GUEST
CHECKED: MM
DATE: 7/8/19

7/29/2019 4:37 PM WK3A1.dgn

STATE	PROJECT NO.
MISS.	HSIP-0055-02(250)

LEGEND

 SLOPE WORK REQ'D (6:1)

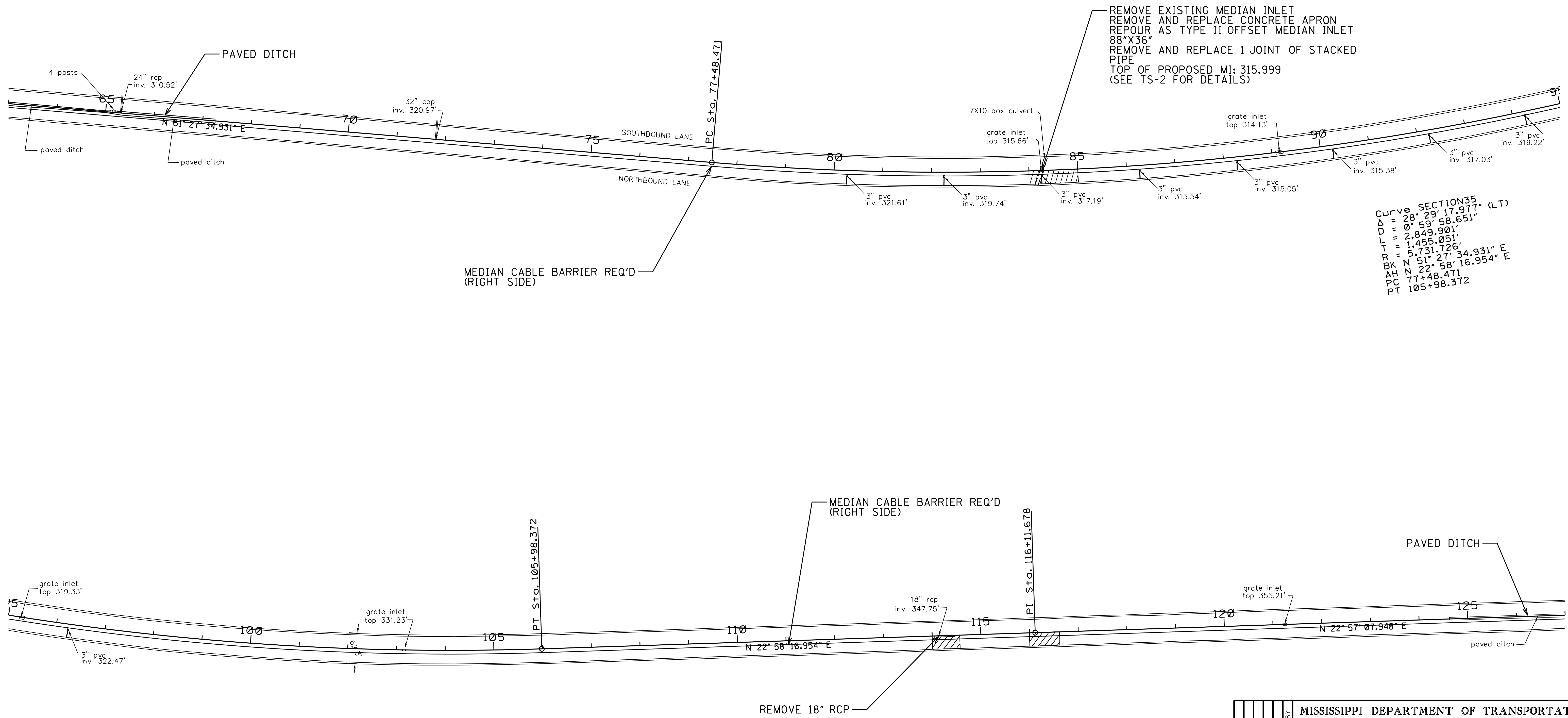
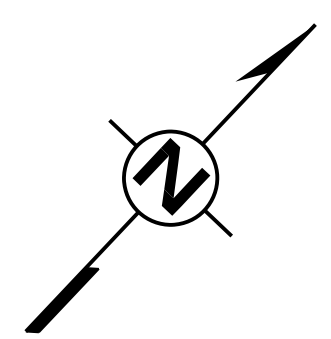

EARTHWORK TOTAL THIS SHEET

Cut		Cu.Yds
Fill	572	Cu.Yds
Excess		Cu.Yds
Surplus		Cu.Yds
Borrow()		Cu.Yds

MISSISSIPPI DEPARTMENT OF TRANSPORTATION

**HOLMES COUNTY SECTION 3
PLAN VIEW**

PROJ. NO.: HSIP-0055-02(250)
COUNTY: HOLMES

FILENAME: wk3A2.dgn

DESIGN TEAM: GUEST CHECKED: MM DATE: 7/8/19

WORKING NUMBER: 18
SHEET NUMBER: 34

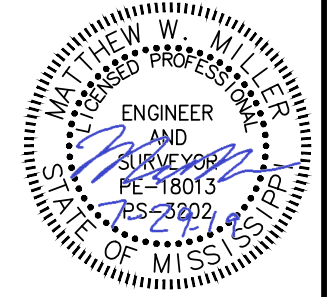

7/29/2019 4:37 PM WK3A2.DGN

LEGEND

 SLOPE WORK REQ'D (6:1)

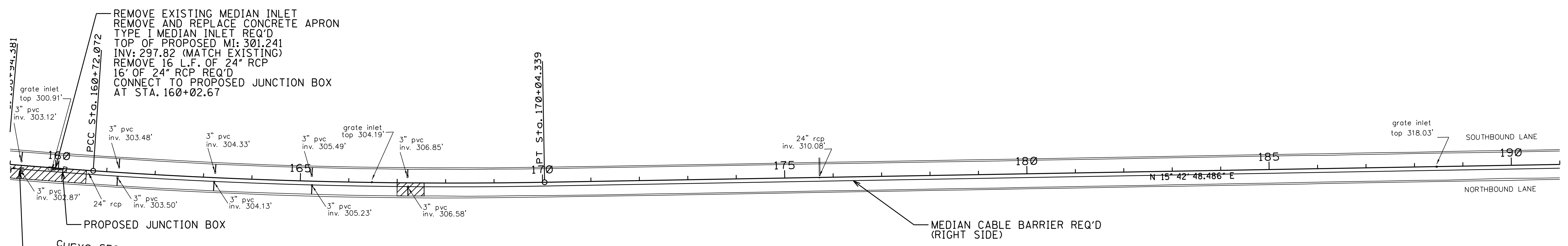
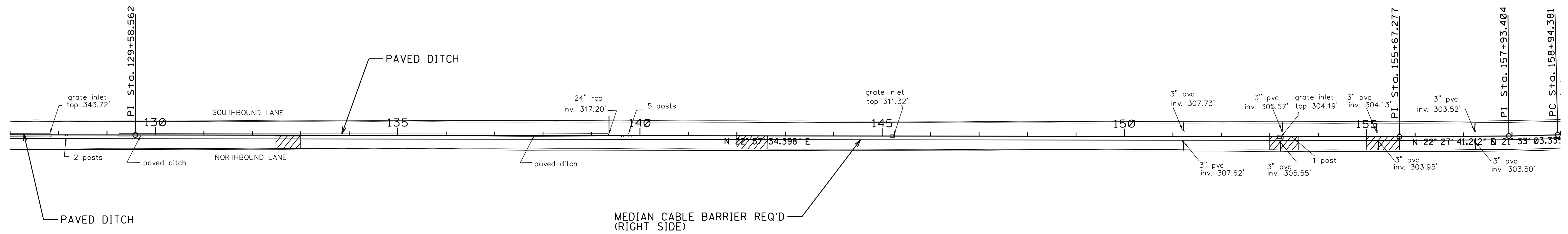
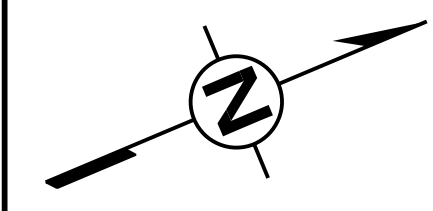

REMOVE EXISTING MEDIAN INLET
 REMOVE AND REPLACE CONCRETE APRON
 TYPE I MEDIAN INLET REQ'D
 TOP OF PROPOSED MI: 301.241
 INV: 297.82 (MATCH EXISTING)
 REMOVE 16 L.F. OF 24" RCP
 16' OF 24" RCP REQ'D
 CONNECT TO PROPOSED JUNCTION BOX
 AT STA. 160+02.67

Curve SECTION36
 Δ = 0° 54' 48.153" (LT)
 D = 0° 30' 50.493"
 L = 177.691'
 R = 88.847'
 T = 11,146.478'
 BK N 21° 33' 03.335" E
 AH N 20° 38' 15.182" E
 PC 158+94.381
 PT 160+72.072

Curve SECTION37
 Δ = 4° 55' 26.696" (LT)
 D = 0° 31' 41.461"
 L = 932.267'
 R = 466.421'
 T = 10,847.700'
 BK N 20° 38' 15.182" E
 AH N 15° 42' 48.486" E
 PC 160+72.072
 PT 170+04.339

EARTHWORK TOTAL THIS SHEET		
Cut		Cu.Yds
Fill	147	Cu.Yds
Excess		Cu.Yds
Surplus		Cu.Yds
Borrow()		Cu.Yds

MISSISSIPPI DEPARTMENT OF TRANSPORTATION	
HOLMES COUNTY SECTION 3 PLAN VIEW	
PROJ. NO.: HSIP-0055-02(250)	
COUNTY: HOLMES	
DATE	WORKING NUMBER
DESIGN TEAM	19
CHECKED	SHEET NUMBER
MM	35
DATE 7/8/19	

7/29/2019 4:37 PM WK3A3.DGN

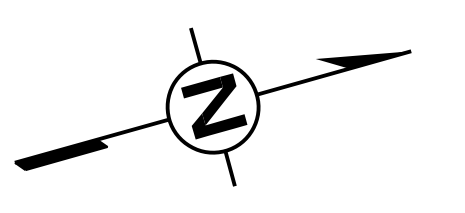

LEGEND

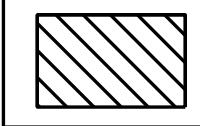
 SLOPE WORK REQ'D (6:1)

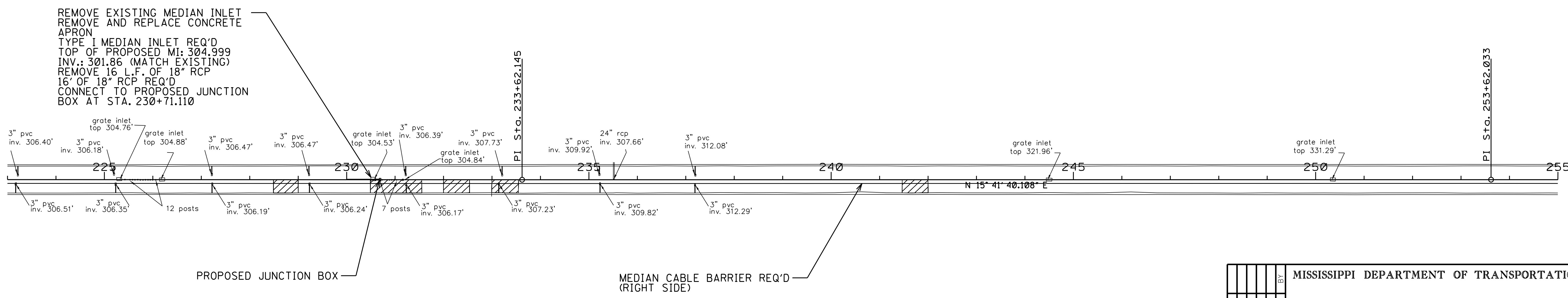
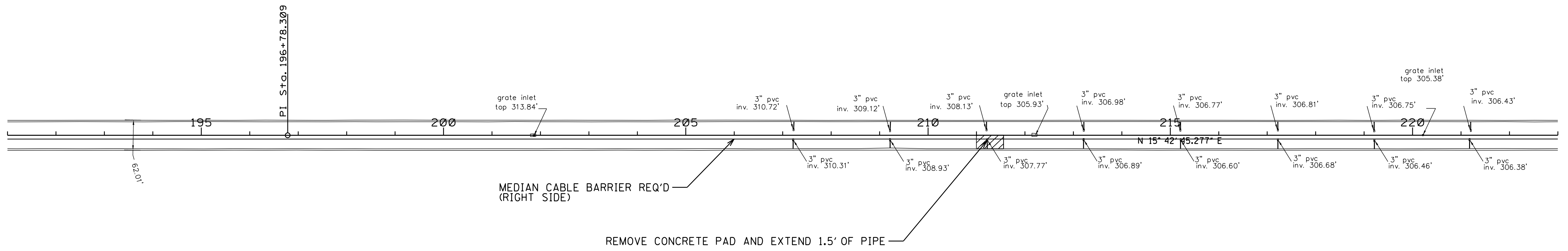

EARTHWORK TOTAL THIS SHEET	
Cut	Cu.Yds
Fill	60 Cu.Yds
Excess	Cu.Yds
Surplus	Cu.Yds
Borrow()	Cu.Yds

MISSISSIPPI DEPARTMENT OF TRANSPORTATION	
HOLMES COUNTY SECTION 3 PLAN VIEW	
PROJ. NO.: HSIP-0055-02(250) COUNTY: HOLMES	
DATE	WORKING NUMBER
DESIGN TEAM	20
CHECKED	SHEET NUMBER
MM	36
DATE 7/8/19	

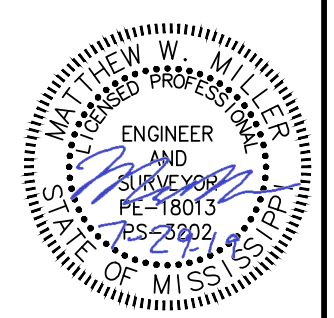

7/29/2019 4:37 PM WK3A4.dgn

STATE	PROJECT NO.
MISS.	HSIP-0055-02(250)

LEGEND

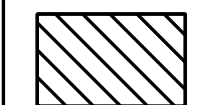
 SLOPE WORK REQ'D (6:1)

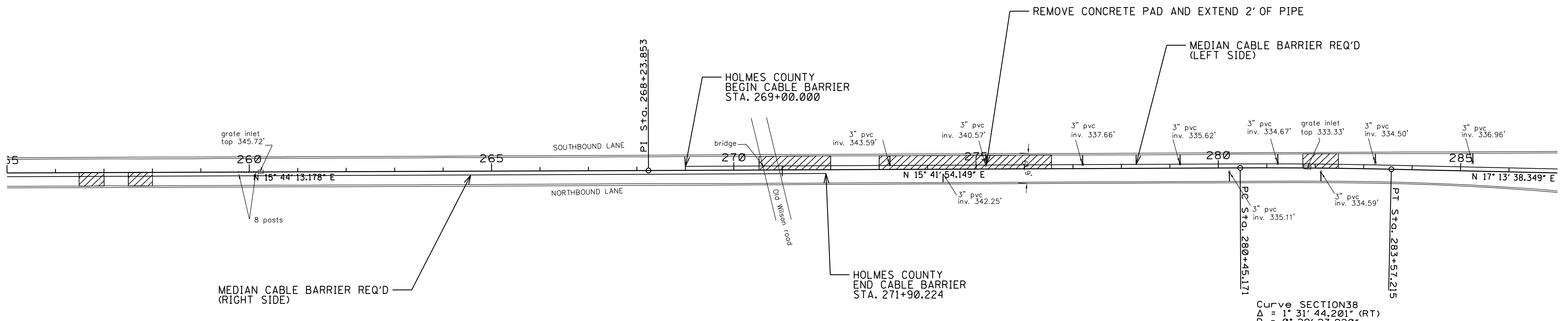
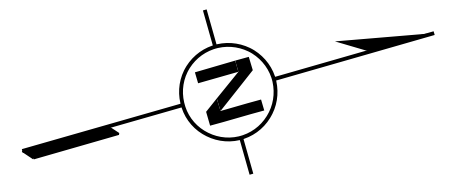

Curve SECTION38
 $\Delta = 1^\circ 31' 44.201''$ (RT)
 $D = 0^\circ 29' 23.920''$
 $L = 312.044'$
 $T = 156.031'$
 $R = 11,693.545'$
 BK N $15^\circ 41' 54.149''$ E
 AH N $17^\circ 13' 38.349''$ E
 PC 280+45.171
 PT 283+57.215

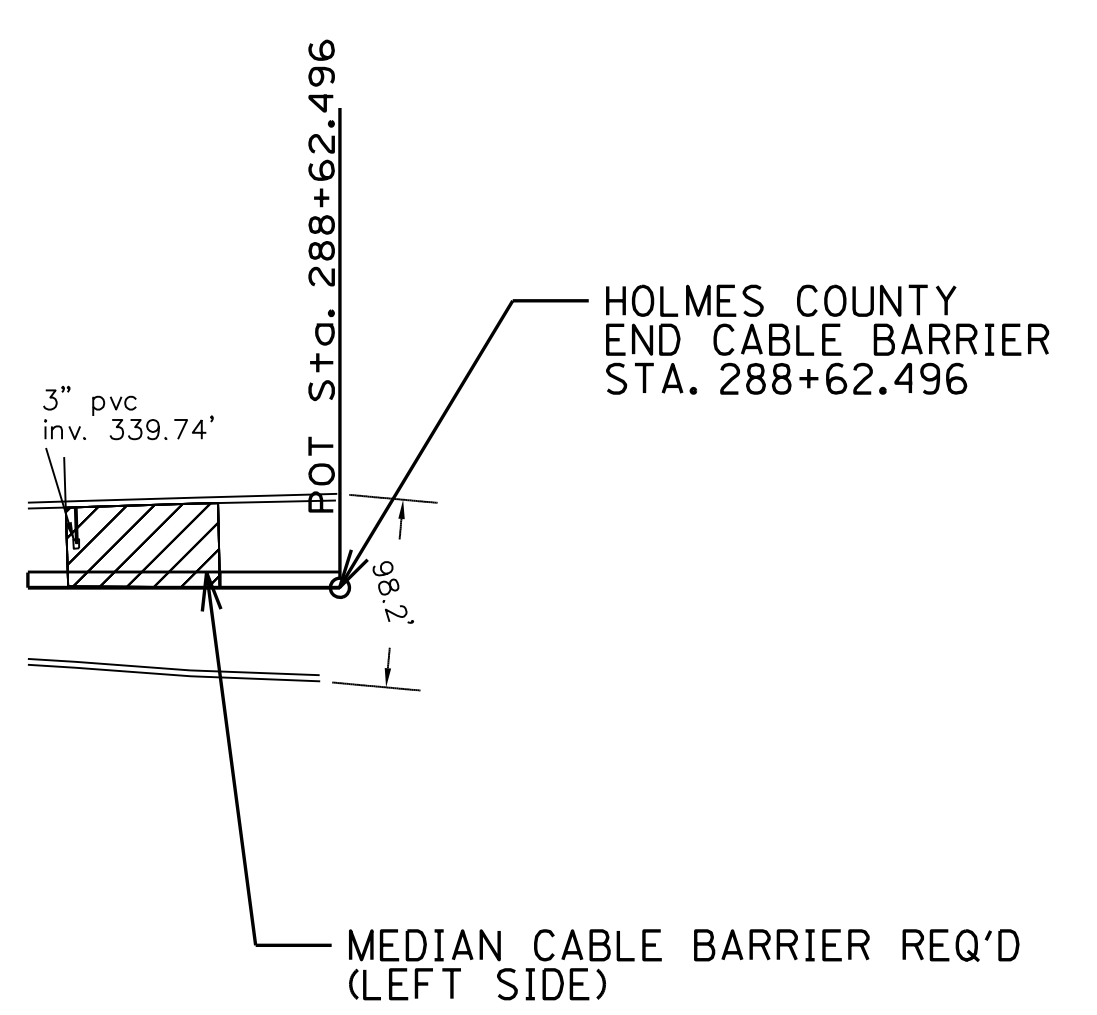

EARTHWORK TOTAL THIS SHEET		
Cut		Cu.Yds
Fill	90	Cu.Yds
Excess		Cu.Yds
Surplus		Cu.Yds
Borrow()		Cu.Yds

MISSISSIPPI DEPARTMENT OF TRANSPORTATION	
HOLMES COUNTY SECTION 3 PLAN VIEW	
PROJ. NO.: HSIP-0055-02(250) COUNTY: HOLMES	
DATE	DESIGN TEAM
FILENAME: wk3A5.dgn	GUEST
REVISION	CHECKED MM
BY	DATE 7/8/19

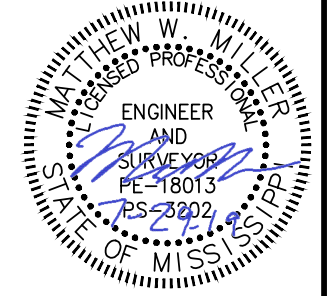

WORKING NUMBER
21

SHEET NUMBER
37

7/29/2019 4:37 PM wk3A5.dgn

STATE	PROJECT NO.
MISS.	HSIP-0055-02(250)

LEGEND

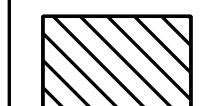
 SLOPE WORK REQ'D (6:1)

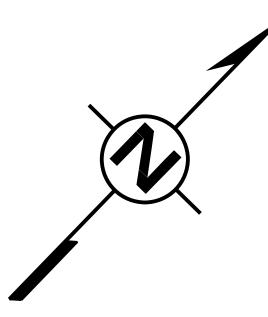

REMOVE EXISTING MEDIAN INLET
 REMOVE AND REPLACE CONCRETE APRON
 TYPE I MEDIAN INLET REQ'D
 TOP OF PROPOSED MI: 301.083
 INV.: 295.95 (MATCH EXISTING)
 REMOVE 3 L.F. OF 24" RCP
 3 L.F. OF 24" RCP REQ'D
 CONNECT TO EXISTING PIPE

HOLMES COUNTY
 BEGIN CABLE BARRIER
 STA. 21+17.166

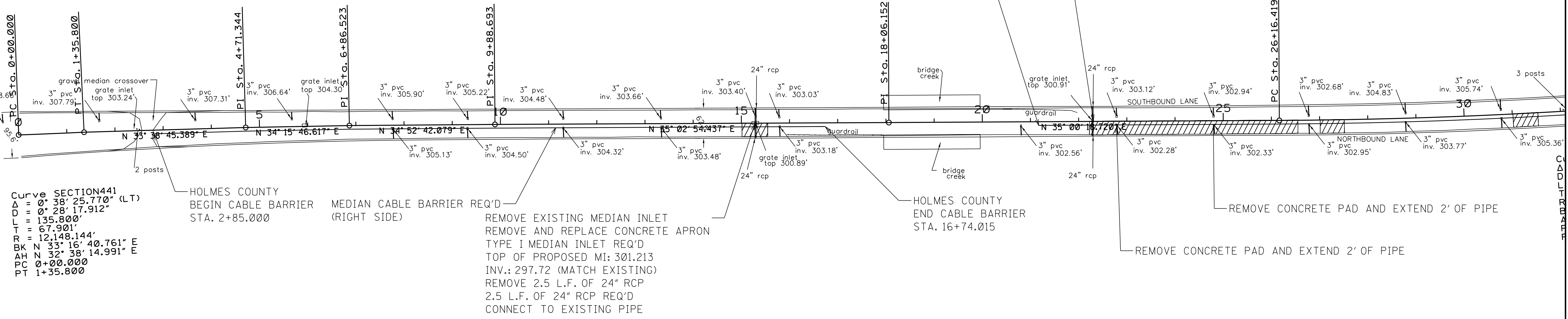

Curve SECTION441
 $\Delta = 0^\circ 38' 25.770''$ (LT)
 $D = 0^\circ 28' 17.912''$
 $L = 135.800'$
 $T = 67.901'$
 $R = 12,148.144'$
 BK N $33^\circ 16' 40.761''$ E
 AH N $32^\circ 38' 14.991''$ E
 PC 0+00.000
 PT 1+35.800

HOLMES COUNTY
 BEGIN CABLE BARRIER
 STA. 2+85.000

MEDIAN CABLE BARRIER REQ'D
 (RIGHT SIDE)

REMOVE EXISTING MEDIAN INLET
 REMOVE AND REPLACE CONCRETE APRON
 TYPE I MEDIAN INLET REQ'D
 TOP OF PROPOSED MI: 301.213
 INV.: 297.72 (MATCH EXISTING)
 REMOVE 2.5 L.F. OF 24" RCP
 2.5 L.F. OF 24" RCP REQ'D
 CONNECT TO EXISTING PIPE

HOLMES COUNTY
 END CABLE BARRIER
 STA. 16+74.015

REMOVE CONCRETE PAD AND EXTEND 2' OF PIPE

REMOVE CONCRETE PAD AND EXTEND 2' OF PIPE

7/29/2019 4:37 PM WK3A6.DGN

REMOVE 99 S.Y. OF CONCRETE PAVED DITCH
 CONCRETE PAVED DITCH REQ'D (8'X110')
 PROPOSED INV. 311.00' - 313.50'

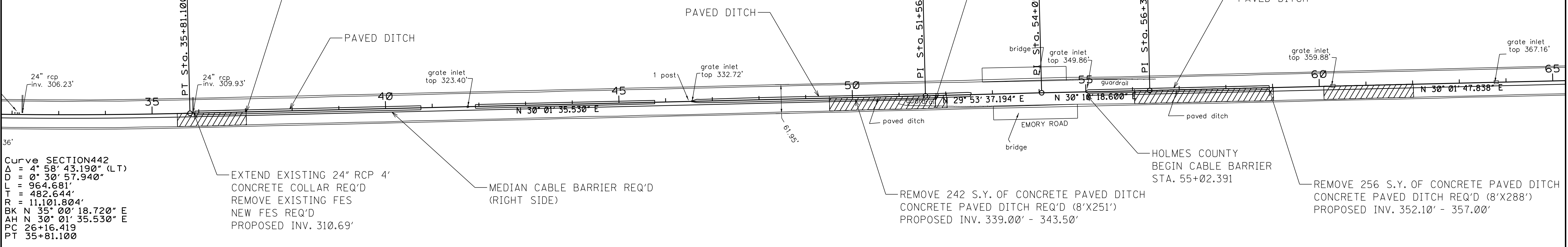

Curve SECTION442
 $\Delta = 4^\circ 58' 43.190''$ (LT)
 $D = 0^\circ 30' 57.940''$
 $L = 964.681'$
 $T = 482.644'$
 $R = 11,101.804'$
 BK N $35^\circ 00' 18.720''$ E
 AH N $30^\circ 01' 35.530''$ E
 PC 26+16.419
 PT 35+81.100

EXTEND EXISTING 24" RCP 4'
 CONCRETE COLLAR REQ'D
 REMOVE EXISTING FES
 NEW FES REQ'D
 PROPOSED INV. 310.69'

MEDIAN CABLE BARRIER REQ'D
 (RIGHT SIDE)

REMOVE 242 S.Y. OF CONCRETE PAVED DITCH
 CONCRETE PAVED DITCH REQ'D (8'X251')
 PROPOSED INV. 339.00' - 343.50'

HOLMES COUNTY
 BEGIN CABLE BARRIER
 STA. 55+02.391

REMOVE 256 S.Y. OF CONCRETE PAVED DITCH
 CONCRETE PAVED DITCH REQ'D (8'X288')
 PROPOSED INV. 352.10' - 357.00'

EARTHWORK TOTAL THIS SHEET		
Cut		Cu.Yds
Fill	515	Cu.Yds
Excess		Cu.Yds
Surplus		Cu.Yds
Borrow()		Cu.Yds

MISSISSIPPI DEPARTMENT OF TRANSPORTATION	
HOLMES COUNTY SECTION 4 PLAN VIEW	
PROJ. NO.: HSIP-0055-02(250) COUNTY: HOLMES	
DATE	FILENAME: wk3A6.dgn
DESIGN TEAM	GUEST
CHECKED	MM
DATE	7/8/19

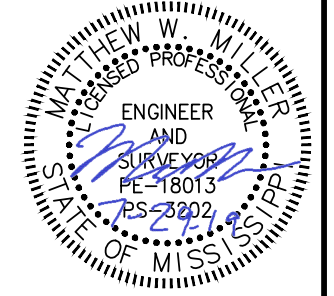

WORKING NUMBER
22

SHEET NUMBER
38

STATE	PROJECT NO.
MISS.	HSIP-0055-02(250)

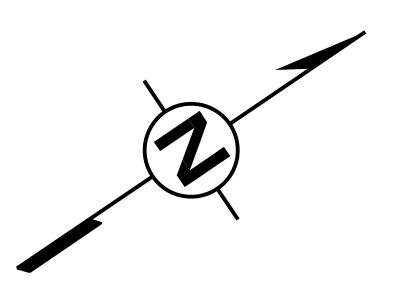

LEGEND

SLOPE WORK REQ'D (6:1)

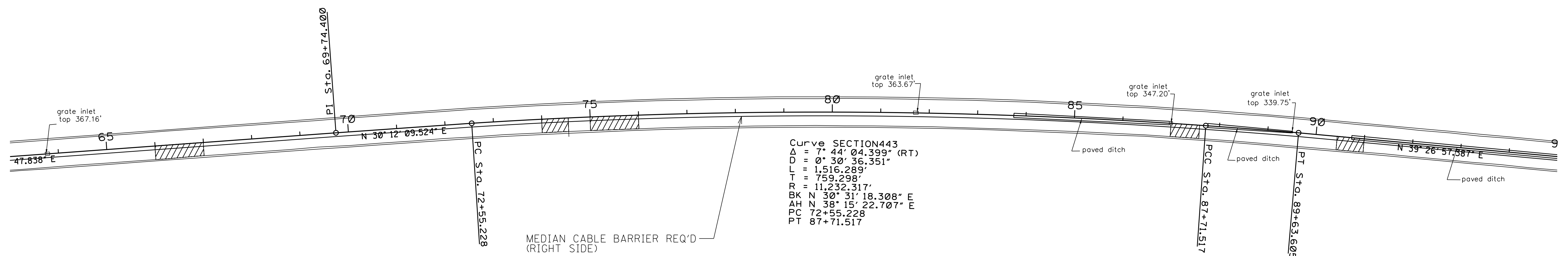

Curve SECTION443
 $\Delta = 7^\circ 44' 04.399''$ (RT)
 $D = 0^\circ 30' 36.351''$
 $L = 1,516.289'$
 $T = 759.298'$
 $R = 11,232.317'$
 BK N $30^\circ 31' 18.308''$ E
 AH N $38^\circ 15' 22.707''$ E
 PC 72+55.228
 PT 87+71.517

Curve SECTION444
 $\Delta = 1^\circ 03' 15.682''$ (RT)
 $D = 0^\circ 32' 56.014''$
 $L = 192.088'$
 $T = 96.047'$
 $R = 10,438.429'$
 BK N $38^\circ 04' 31.070''$ E
 AH N $39^\circ 07' 46.752''$ E
 PC 87+71.517
 PT 89+63.605

Curve SECTION445
 $\Delta = 7^\circ 28' 42.398''$ (LT)
 $D = 0^\circ 57' 58.876''$
 $L = 773.882'$
 $T = 387.491'$
 $R = 5,929.065'$
 BK N $39^\circ 31' 59.007''$ E
 AH N $32^\circ 03' 16.609''$ E
 PC 121+29.975
 PT 129+03.857

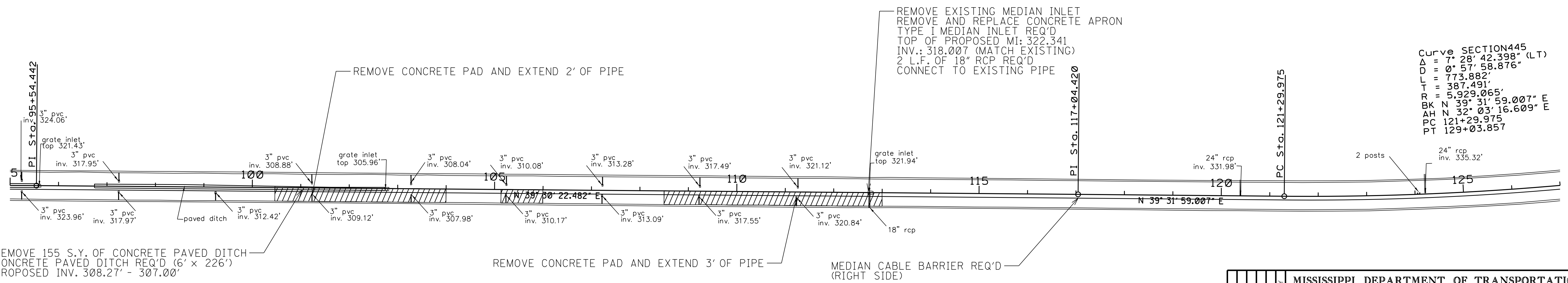

REMOVE 155 S.Y. OF CONCRETE PAVED DITCH
 CONCRETE PAVED DITCH REQ'D (6' x 226')
 PROPOSED INV. 308.27' - 307.00'

REMOVE CONCRETE PAD AND EXTEND 3' OF PIPE

MEDIAN CABLE BARRIER REQ'D (RIGHT SIDE)

EARTHWORK TOTAL THIS SHEET		
Cut		Cu.Yds
Fill	307	Cu.Yds
Excess		Cu.Yds
Surplus		Cu.Yds
Borrow()		Cu.Yds

MISSISSIPPI DEPARTMENT OF TRANSPORTATION	
HOLMES COUNTY SECTION 4 PLAN VIEW	
PROJ. NO.: HSIP-0055-02(250) COUNTY: HOLMES	
DATE	WORKING NUMBER
DESIGN TEAM	39
CHECKED	SHEET NUMBER
DATE	39

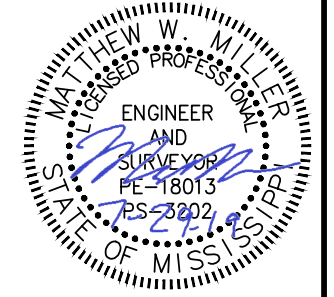

7/29/2019 4:37 PM wk4a2.dgn

STATE	PROJECT NO.
MISS.	HSIP-0055-02(250)

LEGEND

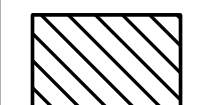
 SLOPE WORK REQ'D (6:1)

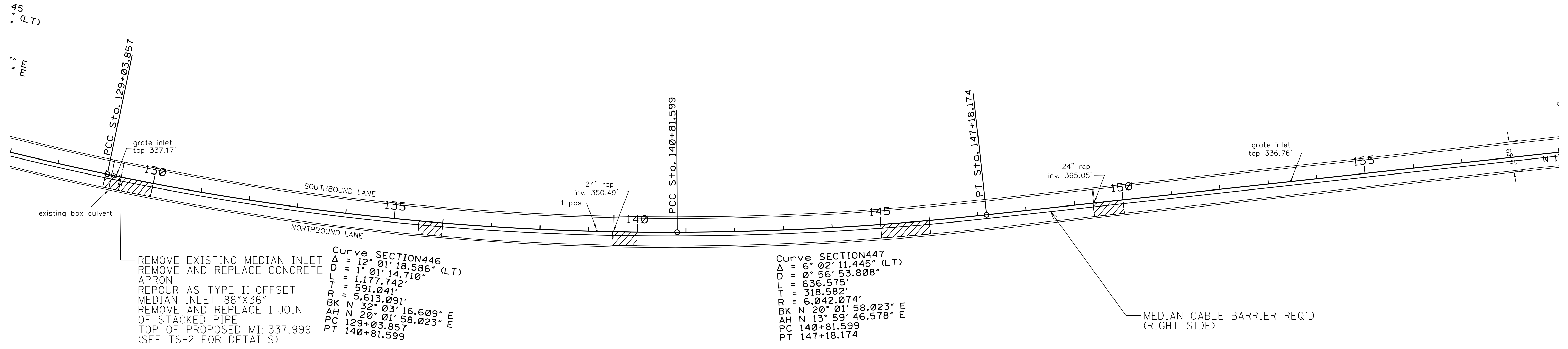
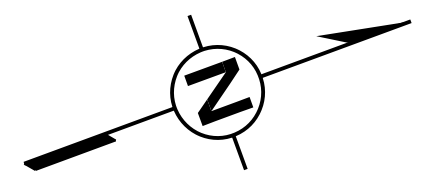

REMOVE EXISTING MEDIAN INLET
 REMOVE AND REPLACE CONCRETE APRON
 REPOUR AS TYPE II OFFSET
 MEDIAN INLET 88"X36"
 REMOVE AND REPLACE 1 JOINT OF STACKED PIPE
 TOP OF PROPOSED MI: 337.999
 (SEE TS-2 FOR DETAILS)

MEDIAN CABLE BARRIER REQ'D (RIGHT SIDE)

REMOVE 130 S.Y. OF CONCRETE PAVED DITCH
 CONCRETE PAVED DITCH REQ'D (8' x 148')
 PROPOSED INV. 402.32' - 406.00'

HOLMES COUNTY
 BEGIN CABLE BARRIER
 STA. 167+11.894

HOLMES COUNTY
 CARROLL COUNTY

REMOVE EXISTING MEDIAN INLET
 REPOUR MEDIAN INLET AS JUNCTION BOX
 REMOVE AND REPLACE CONCRETE APRON
 TYPE I MEDIAN INLET REQ'D
 REMOVE AND REPLACE 1 JOINT OF STACKED PIPE
 TOP OF PROPOSED MI: 416.999
 2 L.F. OF 18" RCP REQ'D
 (SEE TS-2 FOR DETAILS)

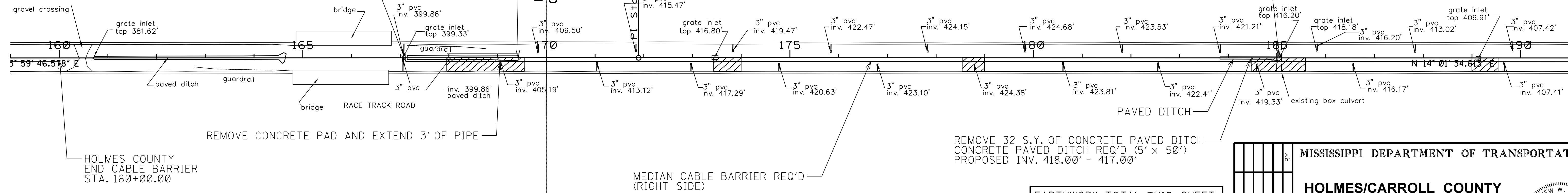

MEDIAN CABLE BARRIER REQ'D (RIGHT SIDE)

EARTHWORK TOTAL THIS SHEET		
Cut		Cu.Yds
Fill	529	Cu.Yds
Excess		Cu.Yds
Surplus		Cu.Yds
Borrow()		Cu.Yds

MISSISSIPPI DEPARTMENT OF TRANSPORTATION

HOLMES/CARROLL COUNTY SECTION 4 PLAN VIEW

PROJ. NO.: HSIP-0055-02(250)
 COUNTY: HOLMES AND CARROLL

WORKING NUMBER: 24
 SHEET NUMBER: 40

FILENAME: wk4A3.dgn
 DESIGN TEAM: GUEST
 CHECKED: MM
 DATE: 7/8/19

DATE: _____ BY: _____

REVISION: _____

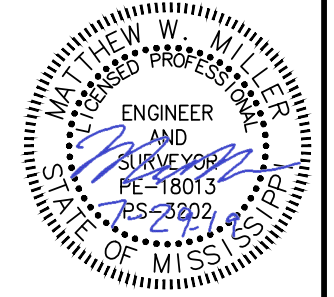

7/29/2019 4:37 PM WK4A3.DGN

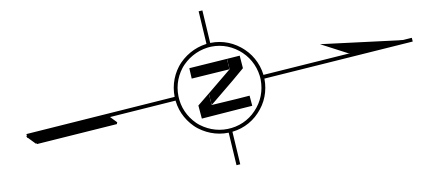

LEGEND

SLOPE WORK REQ'D (6:1)

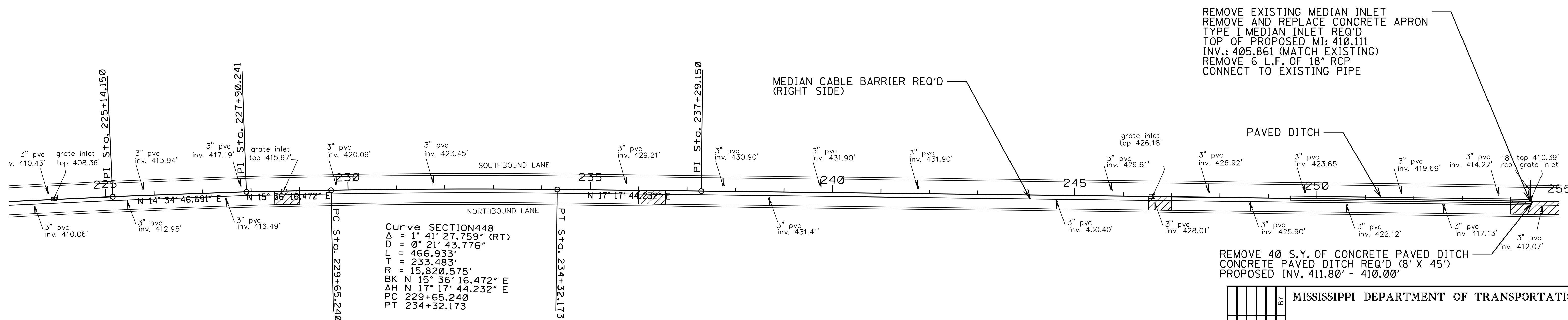
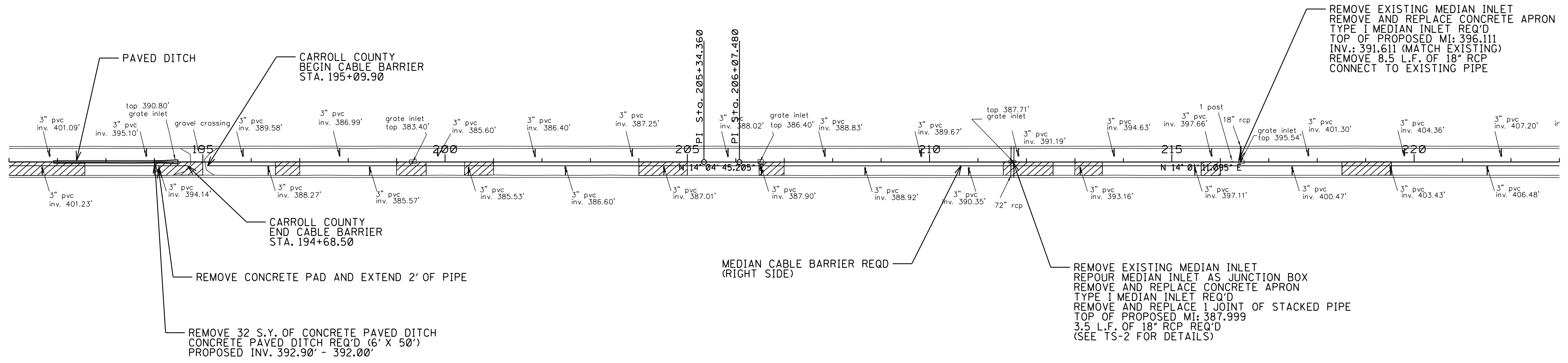

EARTHWORK TOTAL THIS SHEET		
Cut		Cu.Yds
Fill	256	Cu.Yds
Excess		Cu.Yds
Surplus		Cu.Yds
Borrow ()		Cu.Yds

MISSISSIPPI DEPARTMENT OF TRANSPORTATION

CARROLL COUNTY SECTION 4 PLAN VIEW

PROJ. NO.: HSIP-0055-02(250)
 COUNTY: CARROLL

FILENAME: wk4A4.dgn

DESIGN TEAM: GUEST CHECKED: MM DATE: 7/8/19

WORKING NUMBER: 25
 SHEET NUMBER: 41

7/29/2019 4:37 PM WK4A4.dgn

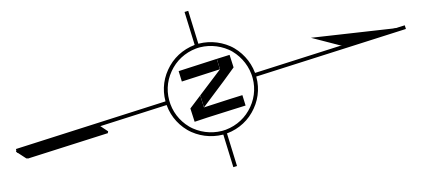

LEGEND

SLOPE WORK REQ'D (6:1)

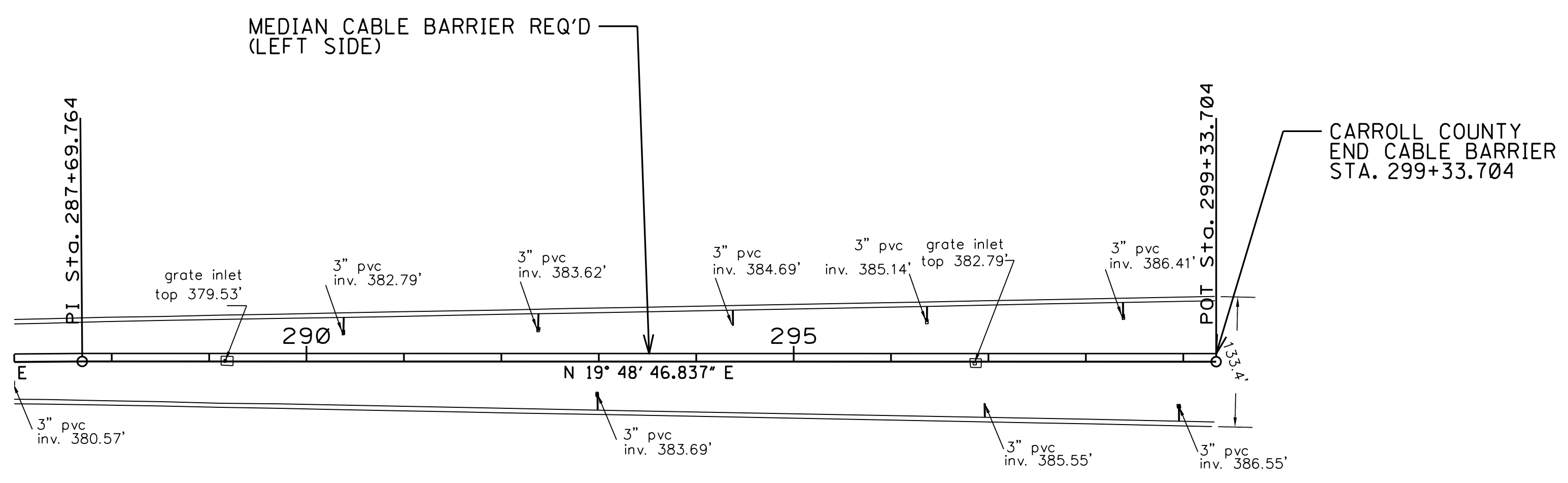
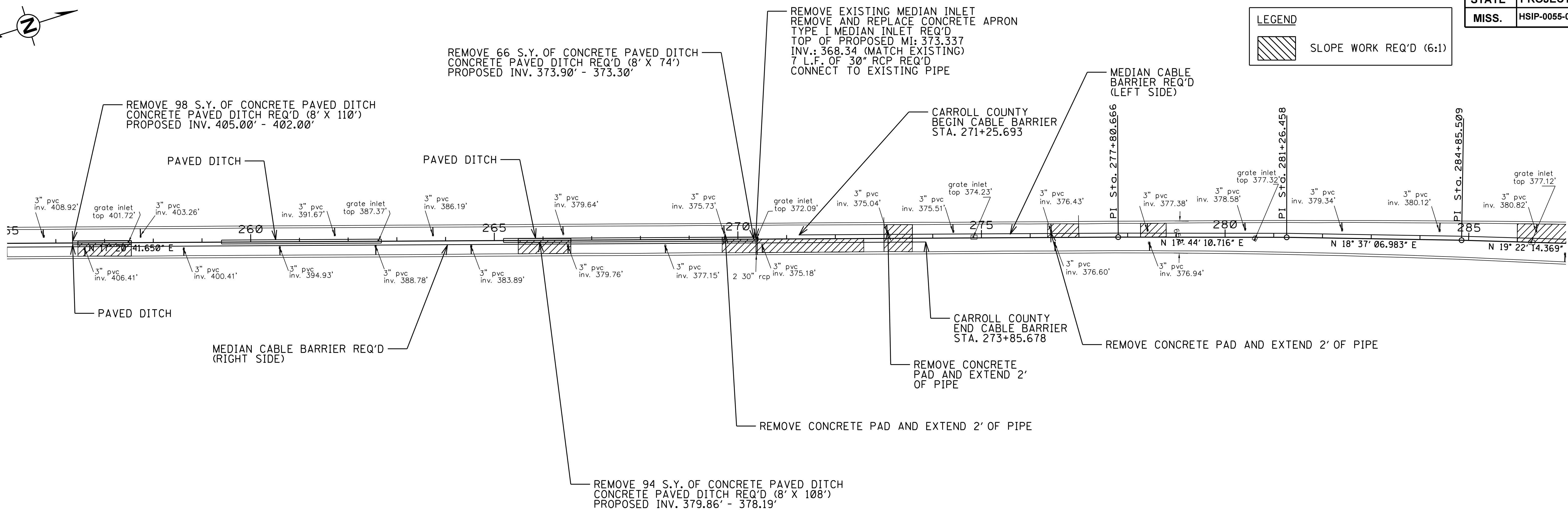

EARTHWORK TOTAL THIS SHEET		
Cut		Cu.Yds
Fill	220	Cu.Yds
Excess		Cu.Yds
Surplus		Cu.Yds
Borrow()		Cu.Yds

MISSISSIPPI DEPARTMENT OF TRANSPORTATION	
CARROLL COUTNY SECTION 4 PLAN VIEW	
PROJ. NO.: HSIP-0055-02(250) COUNTY: CARROLL	
DATE	WORKING NUMBER
DESIGN TEAM	26
GUEST	42
CHECKED	
MM	
DATE	
7/8/19	

7/29/2019 4:37 PM wk4A5.dgn

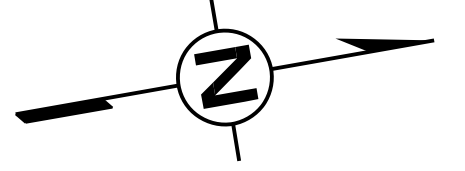

LEGEND

SLOPE WORK REQ'D (6:1)

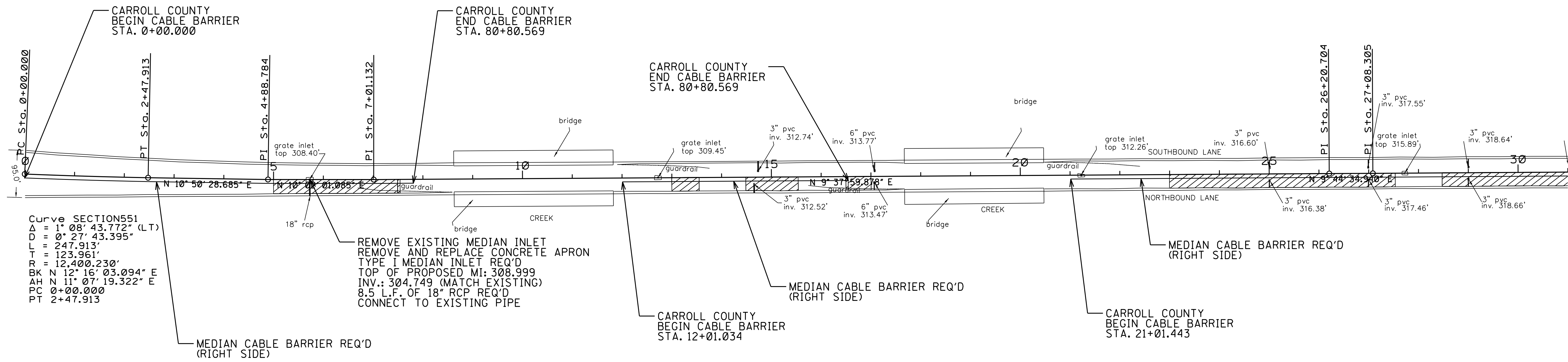

Curve SECTION551
 $\Delta = 1^\circ 08' 43.772''$ (LT)
 $D = 0^\circ 27' 43.395''$
 $L = 247.913'$
 $T = 123.961'$
 $R = 12,400.230'$
 $BK N 12^\circ 16' 03.094'' E$
 $AH N 11^\circ 07' 19.322'' E$
 $PC 0+00.000$
 $PT 2+47.913$

7/29/2019 4:37 PM WK5A1.DGN

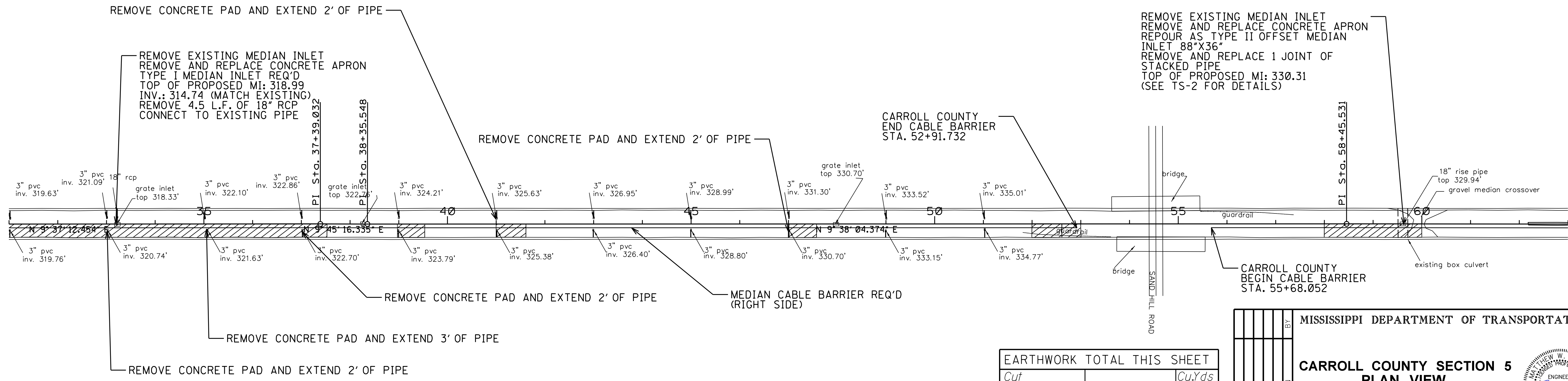

EARTHWORK TOTAL THIS SHEET		
Cut		Cu.Yds
Fill	440	Cu.Yds
Excess		Cu.Yds
Surplus		Cu.Yds
Borrow()		Cu.Yds

MISSISSIPPI DEPARTMENT OF TRANSPORTATION	
CARROLL COUNTY SECTION 5 PLAN VIEW	
PROJ. NO.: HSIP-0055-02(250) COUNTY: CARROLL	
DATE	DESIGN TEAM
BY	CHECKED
REVISION	DATE
FILENAME: wk5A1.dgn	DATE 7/8/19

WORKING NUMBER
27

SHEET NUMBER
43

STATE	PROJECT NO.
MISS.	HSIP-0055-02(250)

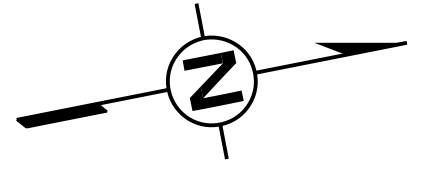

LEGEND

SLOPE WORK REQ'D (6:1)

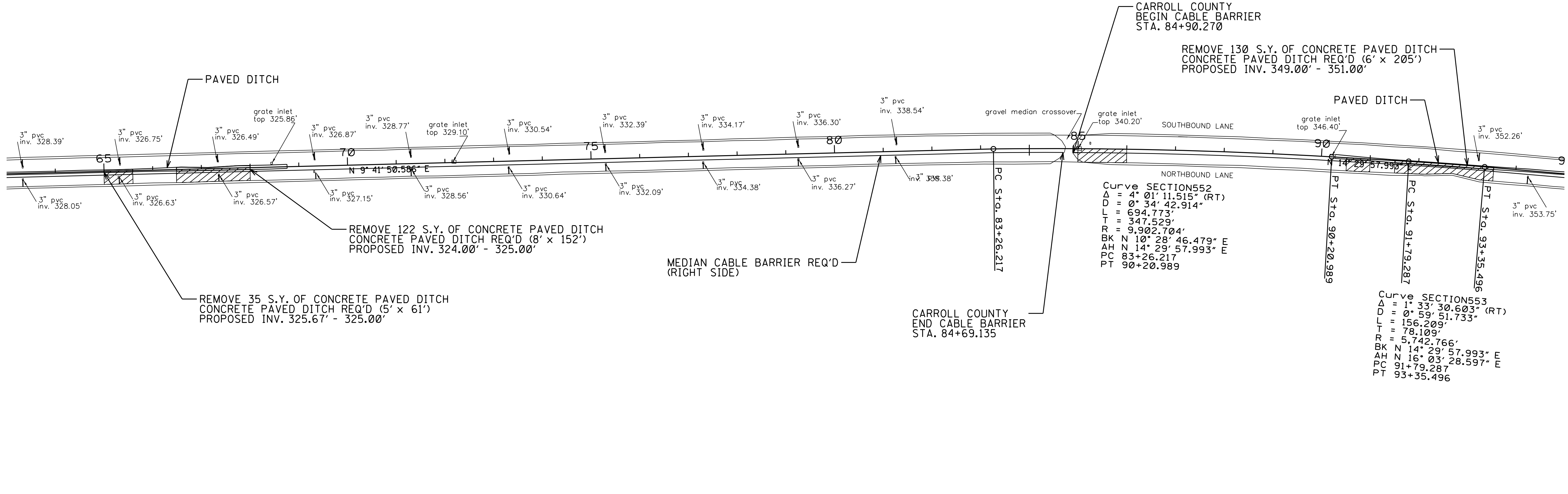

Curve SECTION552
 $\Delta = 4^\circ 01' 11.515''$ (RT)
 $D = 0^\circ 34' 42.914''$
 $L = 694.773'$
 $T = 347.529'$
 $R = 9,902.704'$
 $BK N 10^\circ 28' 46.479'' E$
 $AH N 14^\circ 29' 57.993'' E$
 $PC 83+26.217$
 $PT 90+20.989$

Curve SECTION553
 $\Delta = 1^\circ 33' 30.603''$ (RT)
 $D = 0^\circ 59' 51.733''$
 $L = 156.209'$
 $T = 78.109'$
 $R = 5,742.766'$
 $BK N 14^\circ 29' 57.993'' E$
 $AH N 16^\circ 03' 28.597'' E$
 $PC 91+79.287$
 $PT 93+35.496$

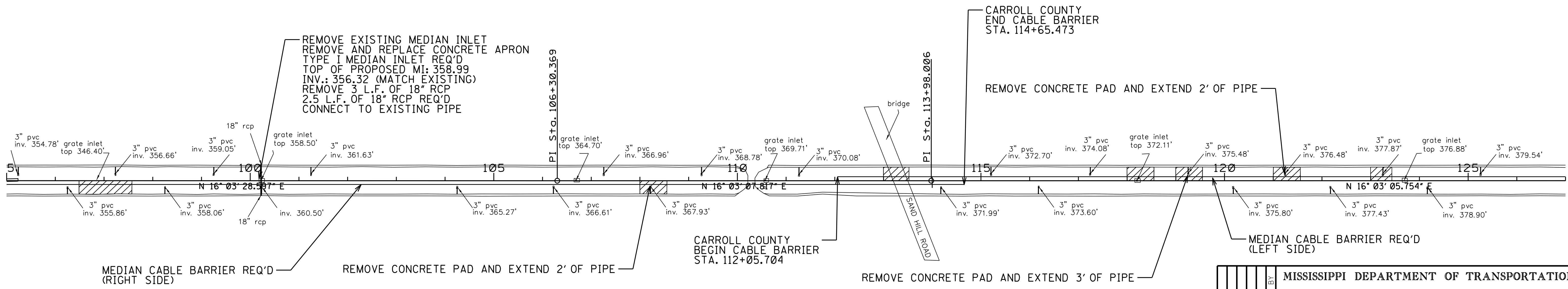

CARROLL COUNTY
 END CABLE BARRIER
 STA. 114+65.473

CARROLL COUNTY
 BEGIN CABLE BARRIER
 STA. 112+05.704

EARTHWORK TOTAL THIS SHEET		
Cut		Cu.Yds
Fill	373	Cu.Yds
Excess		Cu.Yds
Surplus		Cu.Yds
Borrow()		Cu.Yds

MISSISSIPPI DEPARTMENT OF TRANSPORTATION

**CARROLL COUNTY SECTION 5
 PLAN VIEW**

PROJ. NO.: HSIP-0055-02(250)
 COUNTY: CARROLL

FILENAME: wk5A2.dgn

DESIGN TEAM: GUEST CHECKED: MM DATE: 7/8/19

WORKING NUMBER: 28
 SHEET NUMBER: 44

7/29/2019 4:37 PM WK5A2.DGN

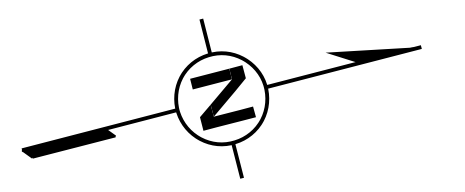

LEGEND

 SLOPE WORK REQ'D (6:1)

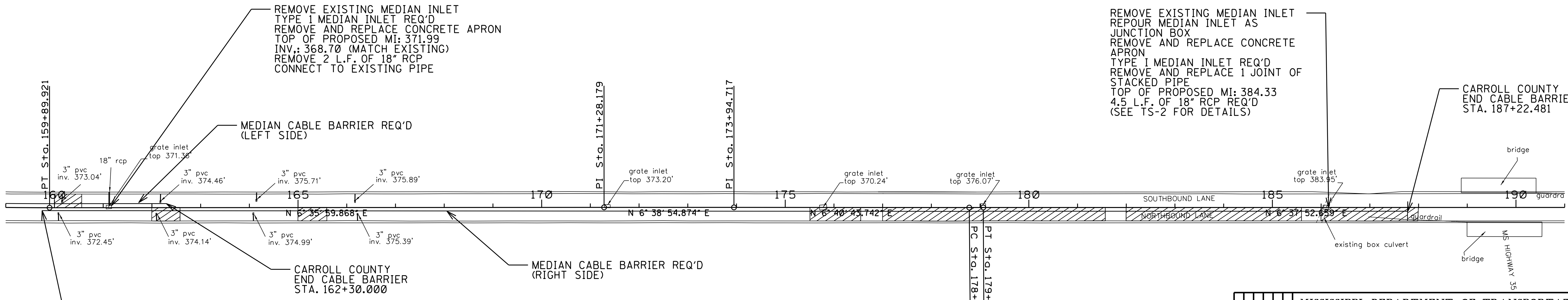
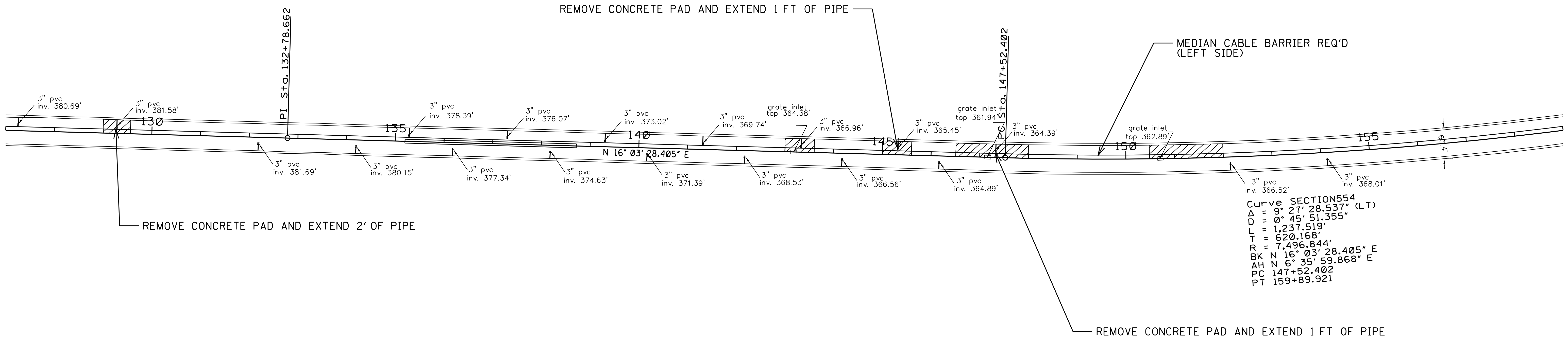

Curve SECTION 555
 $\Delta = 0^{\circ} 11' 11.245''$ (RT)
 $D = 0^{\circ} 38' 53.114''$
 $L = 28.770'$
 $T = 14.385'$
 $R = 8,840.751'$
 BK N $6^{\circ} 08' 09.906''$ E
 AH N $6^{\circ} 19' 21.151''$ E
 PC 178+77.742
 PT 179+06.512

EARTHWORK TOTAL THIS SHEET	
Cut	Cu.Yds
Fill	445 Cu.Yds
Excess	Cu.Yds
Surplus	Cu.Yds
Borrow()	Cu.Yds

MISSISSIPPI DEPARTMENT OF TRANSPORTATION	
CARROLL COUNTY SECTION 5 PLAN VIEW	
PROJ. NO.: HSIP-0055-02(250) COUNTY: CARROLL	
DATE	WORKING NUMBER
DESIGN TEAM	29
GUEST	SHEET NUMBER
CHECKED	45
MM	
DATE	
7/8/19	

7/29/2019 4:37 PM wk5A3.dgn

STATE	PROJECT NO.
MISS.	HSIP-0055-02(250)

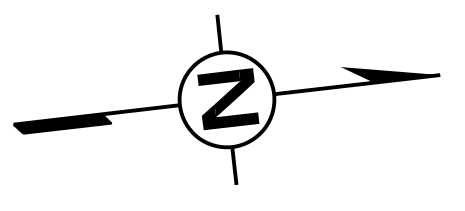

LEGEND

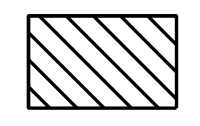
 SLOPE WORK REQ'D (6:1)

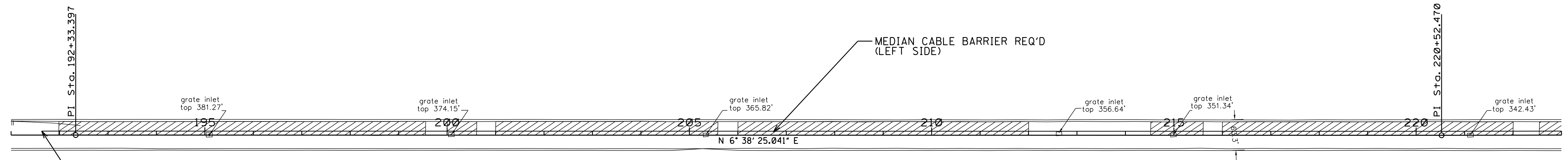

CARROLL COUNTY
END CABLE BARRIER
STA. 191+63.333

MEDIAN CABLE BARRIER REQ'D
(LEFT SIDE)

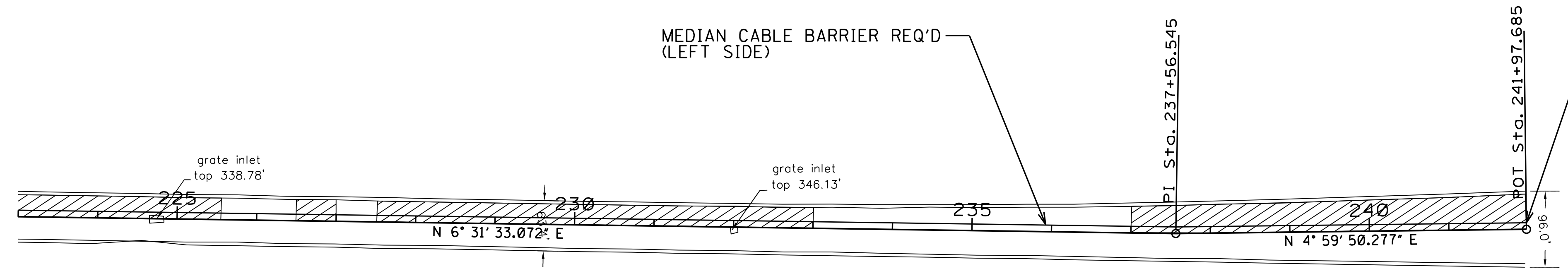

MEDIAN CABLE BARRIER REQ'D
(LEFT SIDE)

CARROLL COUNTY
END CABLE BARRIER
STA. 241+97.685

EARTHWORK TOTAL THIS SHEET

Cut		Cu.Yds
Fill	890	Cu.Yds
Excess		Cu.Yds
Surplus		Cu.Yds
Borrow()		Cu.Yds

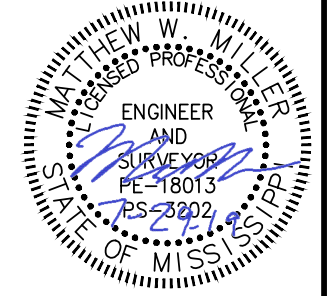
MISSISSIPPI DEPARTMENT OF TRANSPORTATION	
CARROLL COUNTY SECTION 5 PLAN VIEW	
	
PROJ. NO.: HSIP-0055-02(250) COUNTY: CARROLL	
WORKING NUMBER 30	SHEET NUMBER 46
FILENAME: wk5A4.dgn DESIGN TEAM: GUEST CHECKED: MM DATE: 7/8/19	

7/29/2019 4:37 PM WK5A4.dgn

STATE	PROJECT NO.
MISS.	HSIP-0055-02(250)

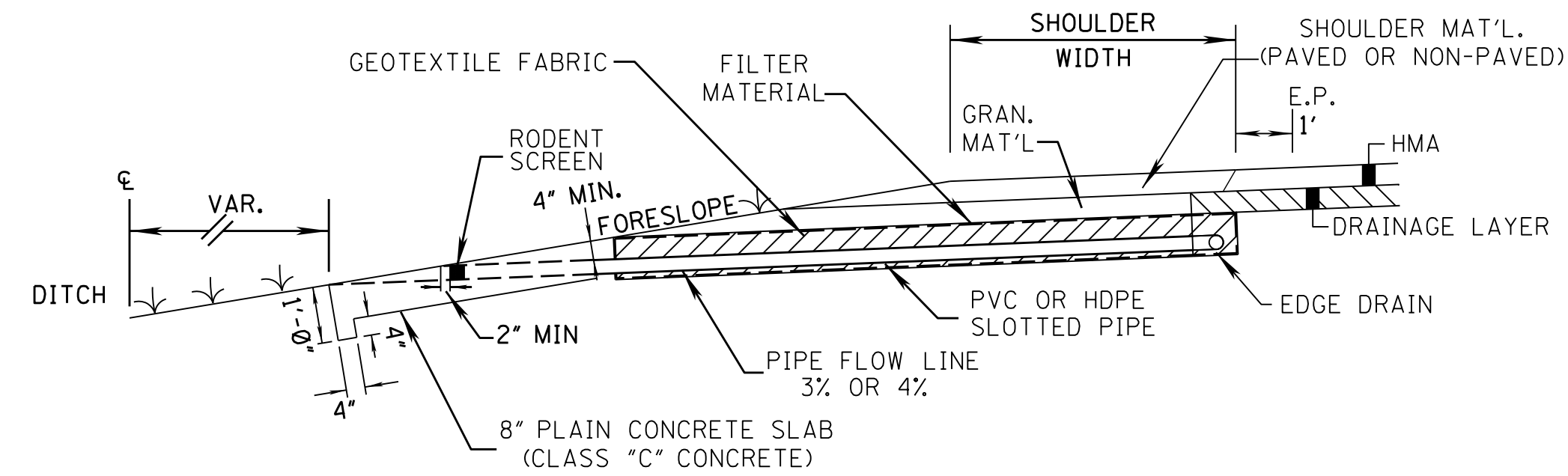
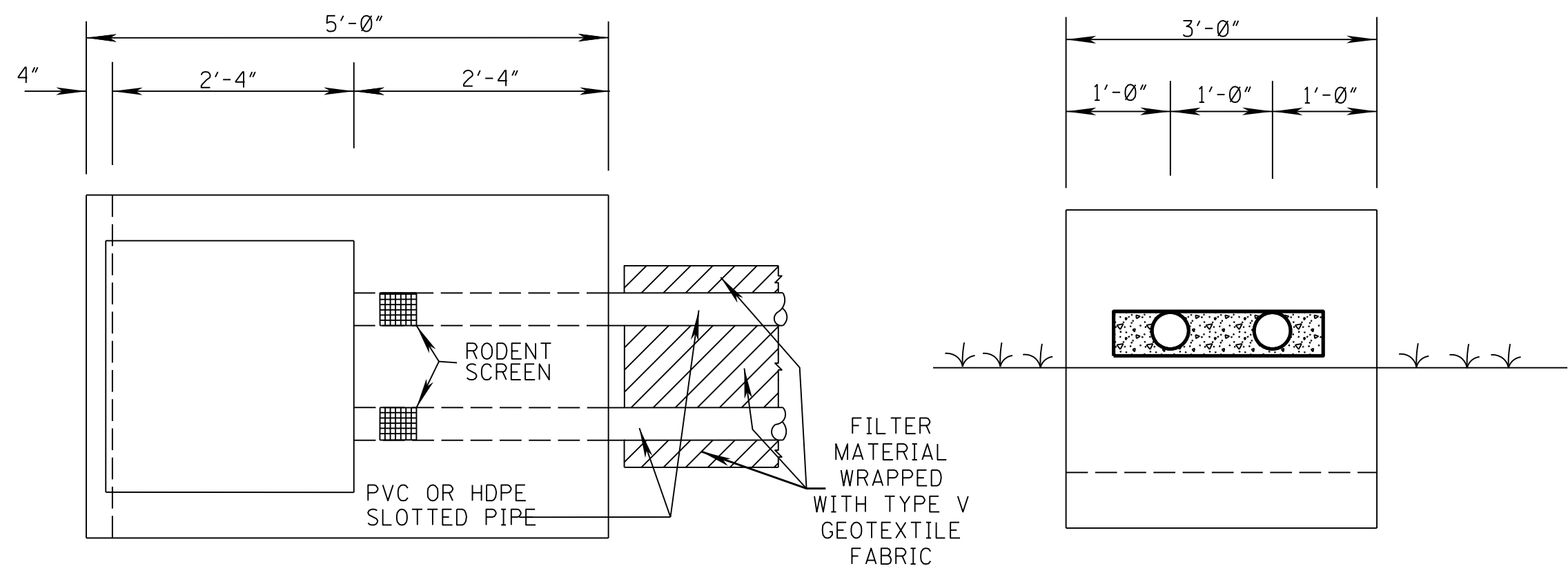

DETAIL OF DUAL EDGEDRAIN OUTLET/VENT APRON

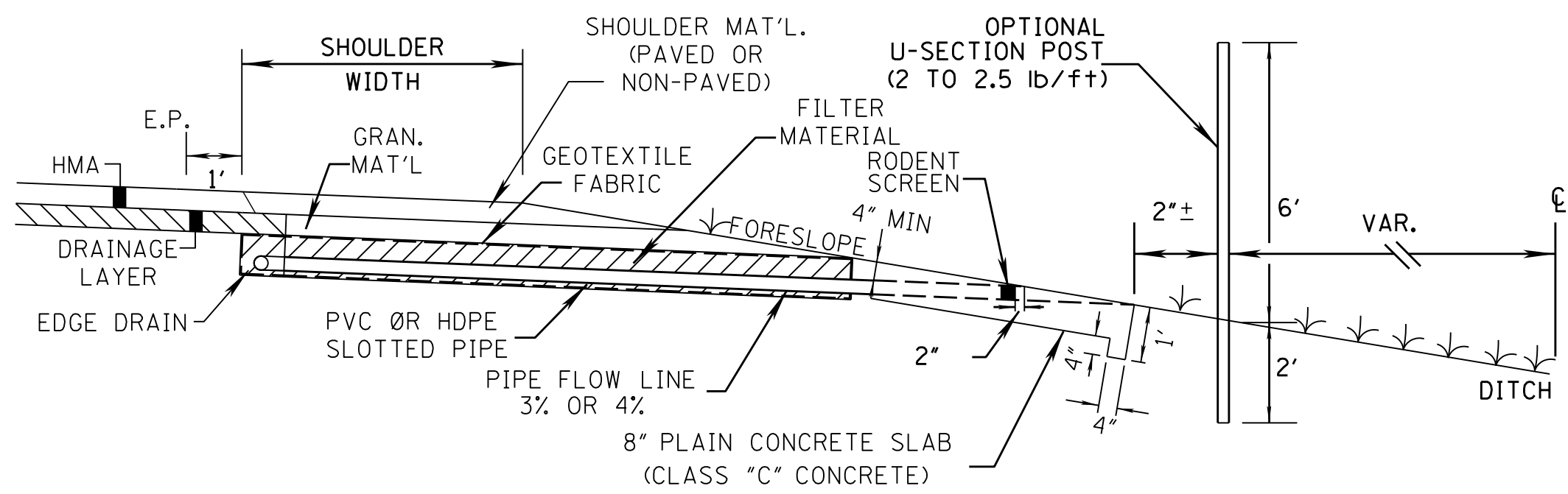
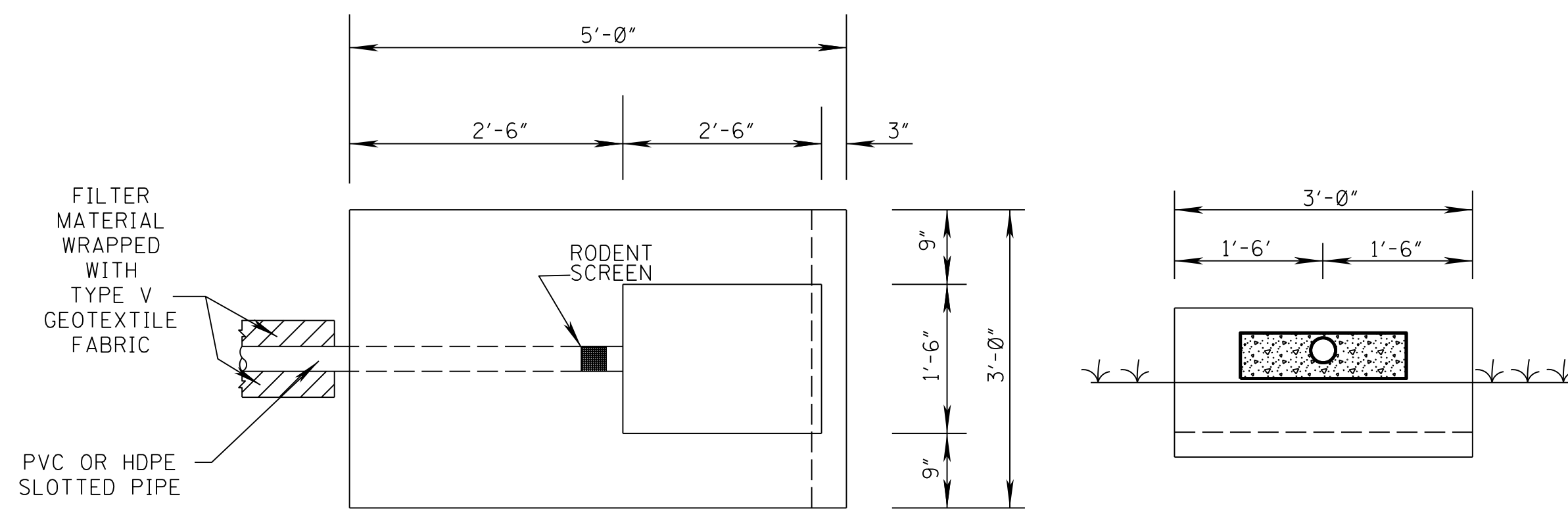

DETAIL OF EDGEDRAIN OUTLET/VENT APRON

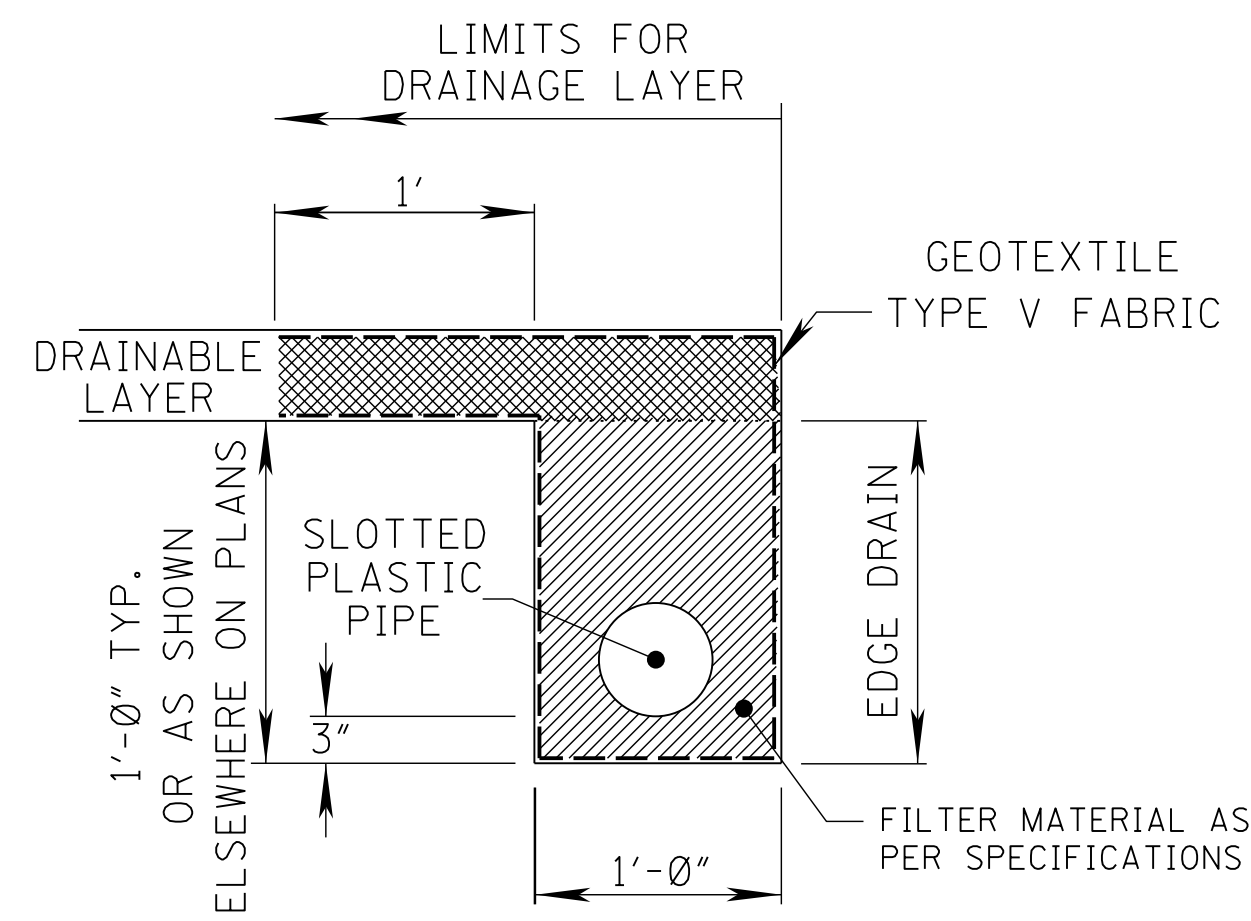

DETAIL "A"

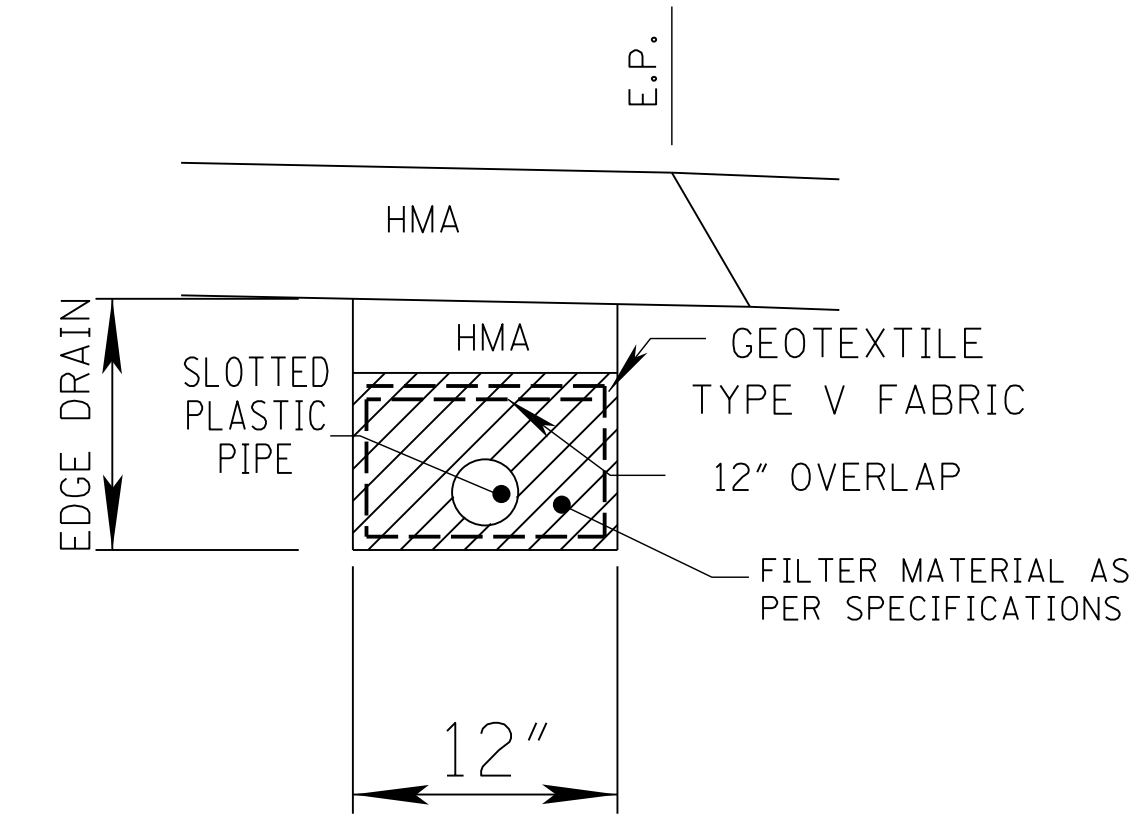

DETAIL "B"

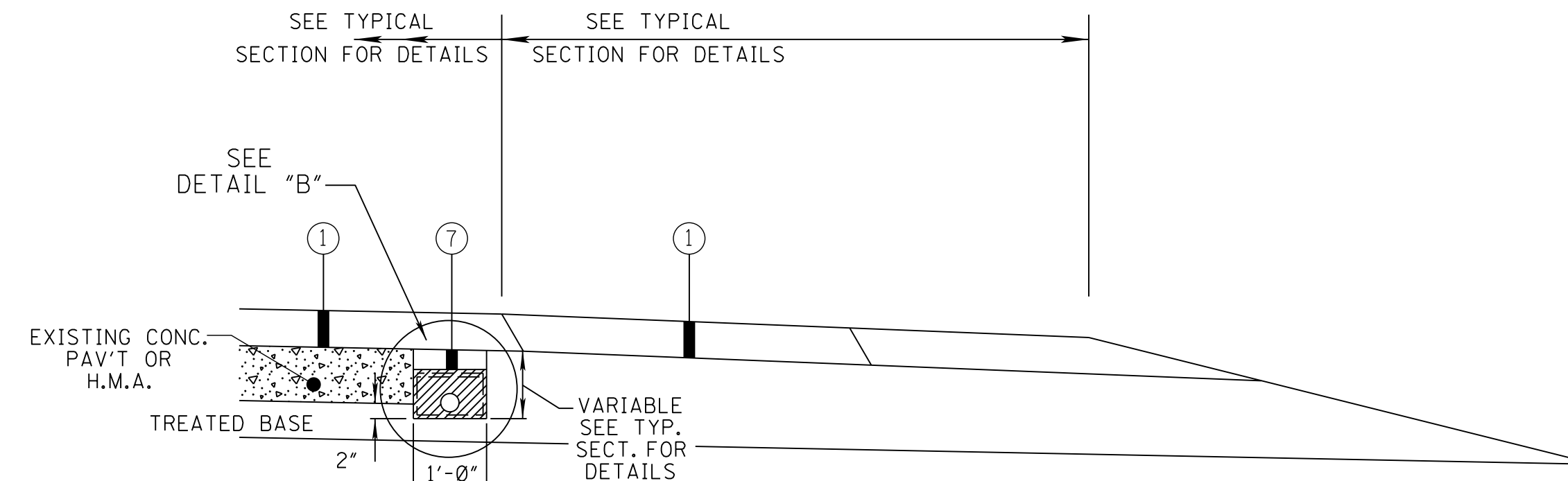

EDGE DRAIN ADDED TO EXISTING FACILITY

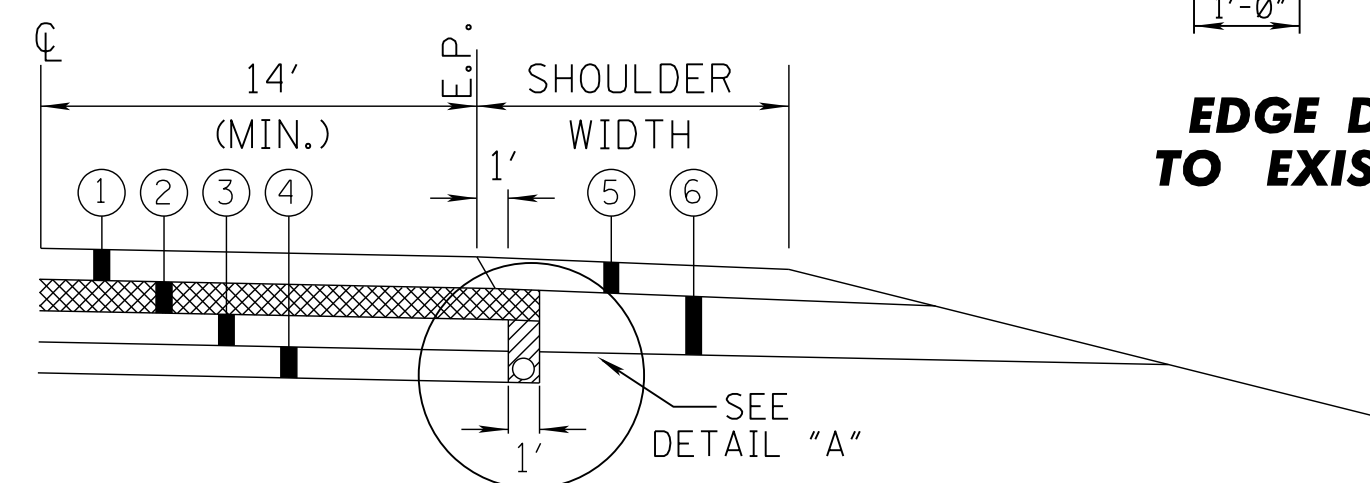

OPEN SHOULDER DETAIL

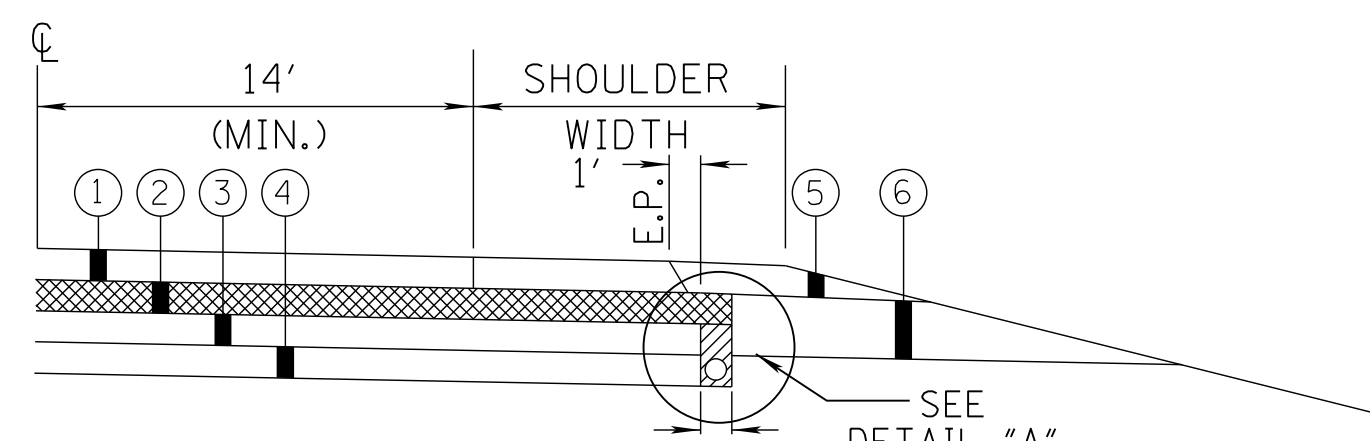

OPEN SHOULDER WITH PAVED SHOULDER DETAIL

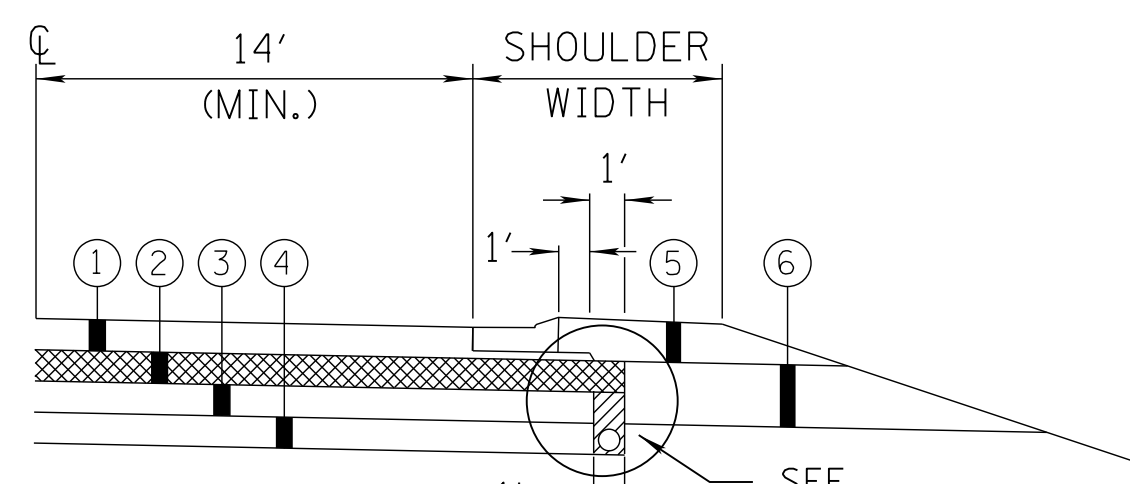

CURBED FACILITY DETAIL

- ① HMA
- ② DRAINABLE LAYER
- ③ LFA GRANULAR OR CRUSHED AGGREGATE
- ④ CHEMICALLY TREATED SUB-GRADE
- ⑤ SHOULDER GRANULAR
- ⑥ UNTREATED GRANULAR
- ⑦ 3" HOT MIX ASPHALT

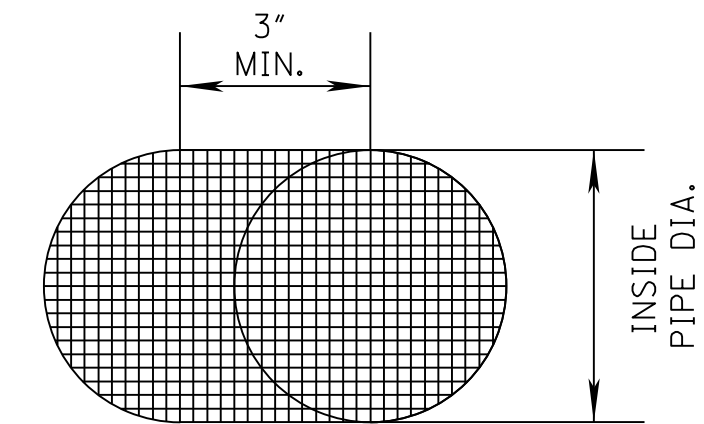

DETAIL OF RODENT SCREEN

3" x 3" GALVANIZED HARDWARE CLOTH
0.063" WIRE OR EQUAL FORMED TO FIT SNUG TO INSIDE OF PIPE. COST OF THE RODENT SCREEN TO BE ABSORBED IN PAY ITEM 907-605-GG (EDGE DRAIN OUTLET/VENT, COMPLETE IN PLACE) (SEE NOTE 6 EDO-2)

NOTES :

URBAN EDGE DRAIN OUTLETS TO TIE INTO INLETS. ALL COSTS SHALL BE COVERED UNDER OUTLET/VENT PAY ITEMS.

EDGE DRAINS SHALL BE REQUIRED ONLY ON THE LOW SIDE OF SUPERELEVATION.

0.363 C.Y. CLASS "C" CONCRETE REQUIRED FOR 5' x 3' APRON.

FOR MORE DETAILS SEE SHEET EDO-2

ALL DIMENSIONS ARE IN in. EXCEPT WHERE NOTED

BY		MISSISSIPPI DEPARTMENT OF TRANSPORTATION	
REVISION		<p align="center">EDGE DRAIN DETAIL CONCRETE APRON AND RODENT SCREEN</p>	
DATE			
DESIGN TEAM		<p>PROJ. NO.: HSIP-0055-02(250) COUNTY: COPIAH, HOLMES, CARROLL</p>	
CHECKED		<p>WORKING NUMBER EDO-1</p>	
DATE		<p>SHEET NUMBER 47</p>	
DESIGN TEAM		<p>FILENAME: EDO-1.dgn DATE: 7/8/19</p>	

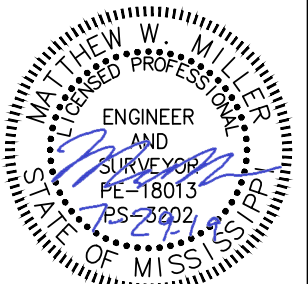

STATE	PROJECT NO.
MISS.	HSIP-0055-02(250)

METRIC PLAN C.A.D.D. SECTION
ROADWAY DESIGN DIVISION
MISSISSIPPI DEPARTMENT OF TRANSPORTATION

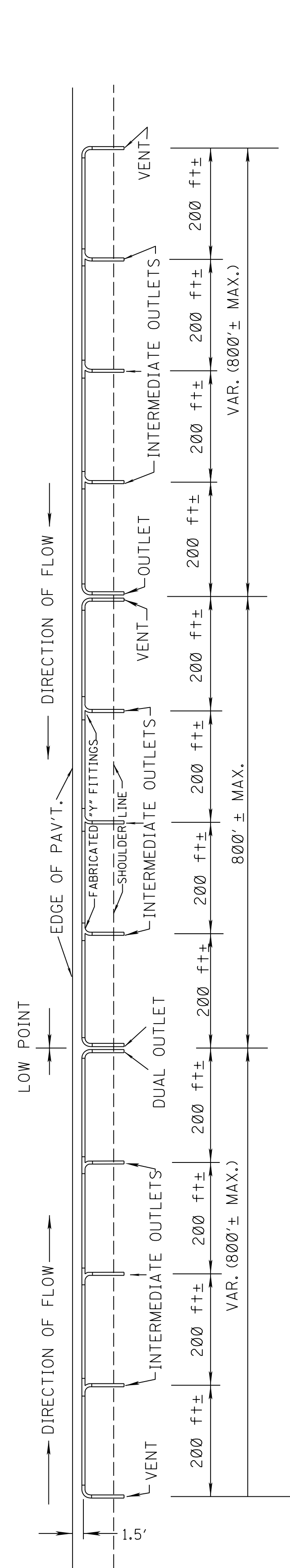

TYPICAL EDGE DRAIN INSTALLATION

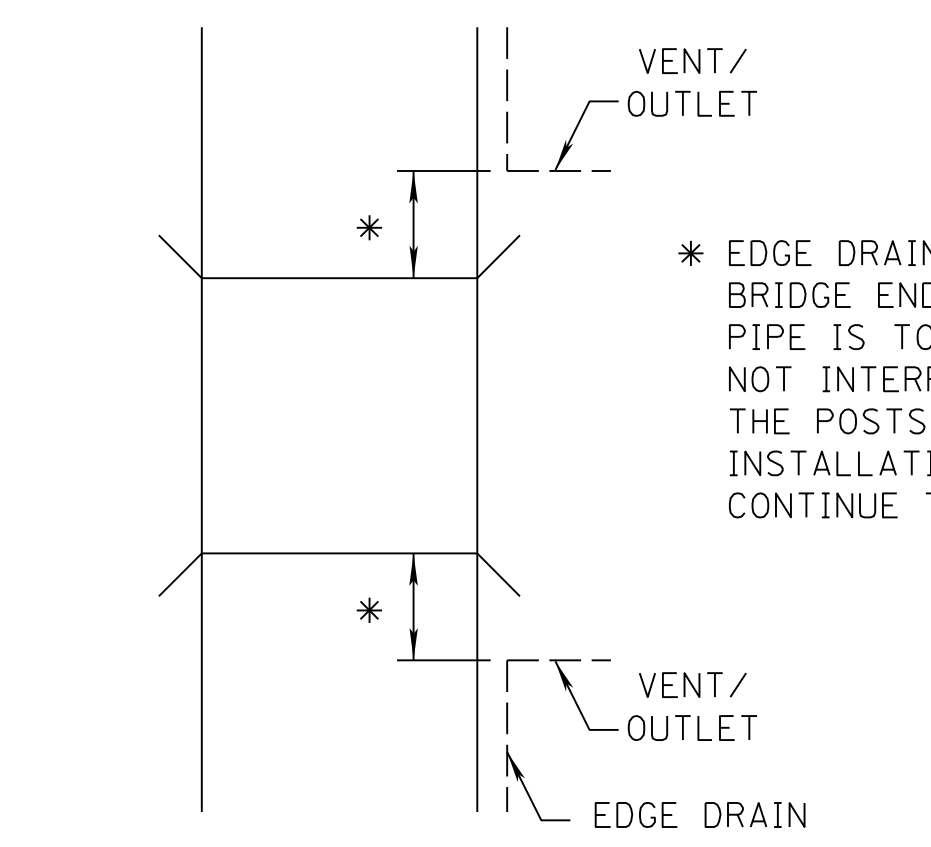

EDGE DRAIN @ BRIDGE

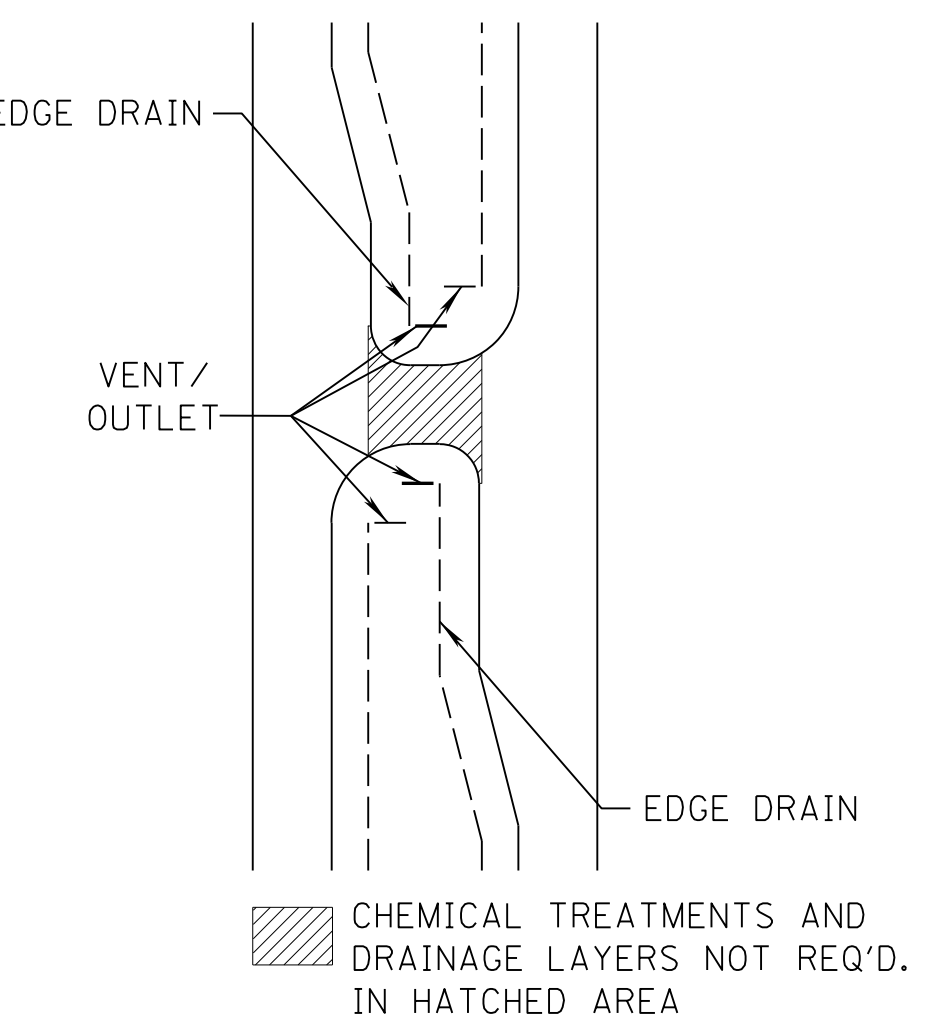

EDGE DRAIN @ X-OVER STOP EDGE DRAIN @ RADIUS POINT

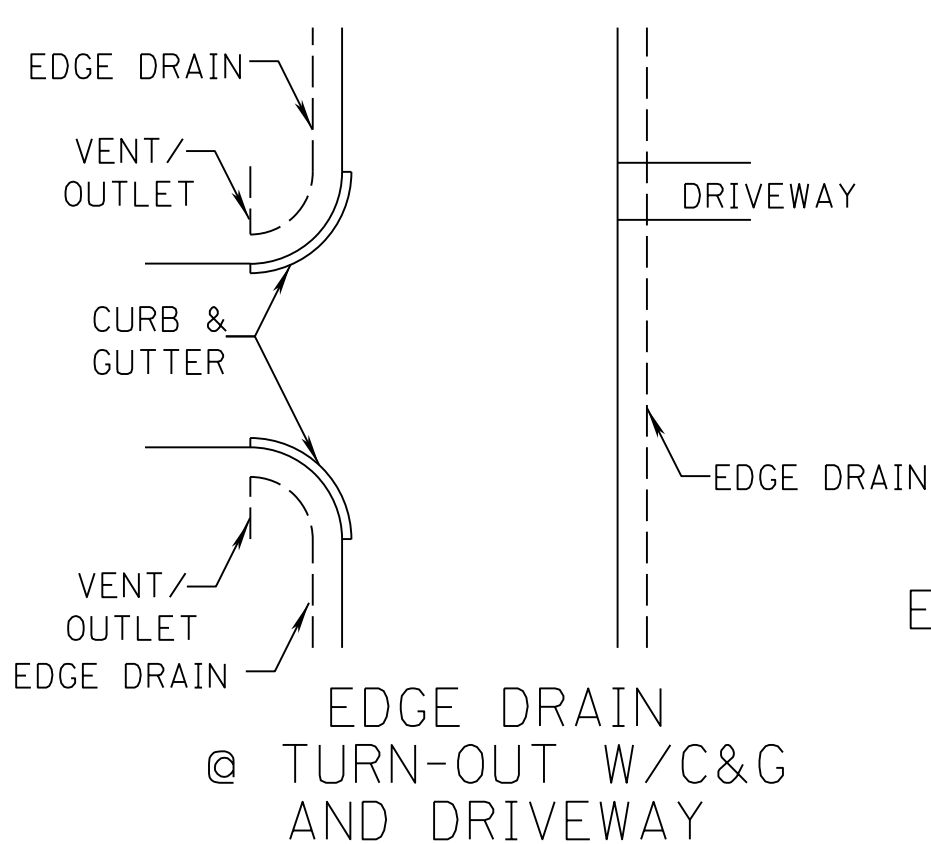

EDGE DRAIN @ TURN-OUT W/C&G AND DRIVEWAY



EDGE DRAIN @ ENTRANCE AND EXIT RAMPS

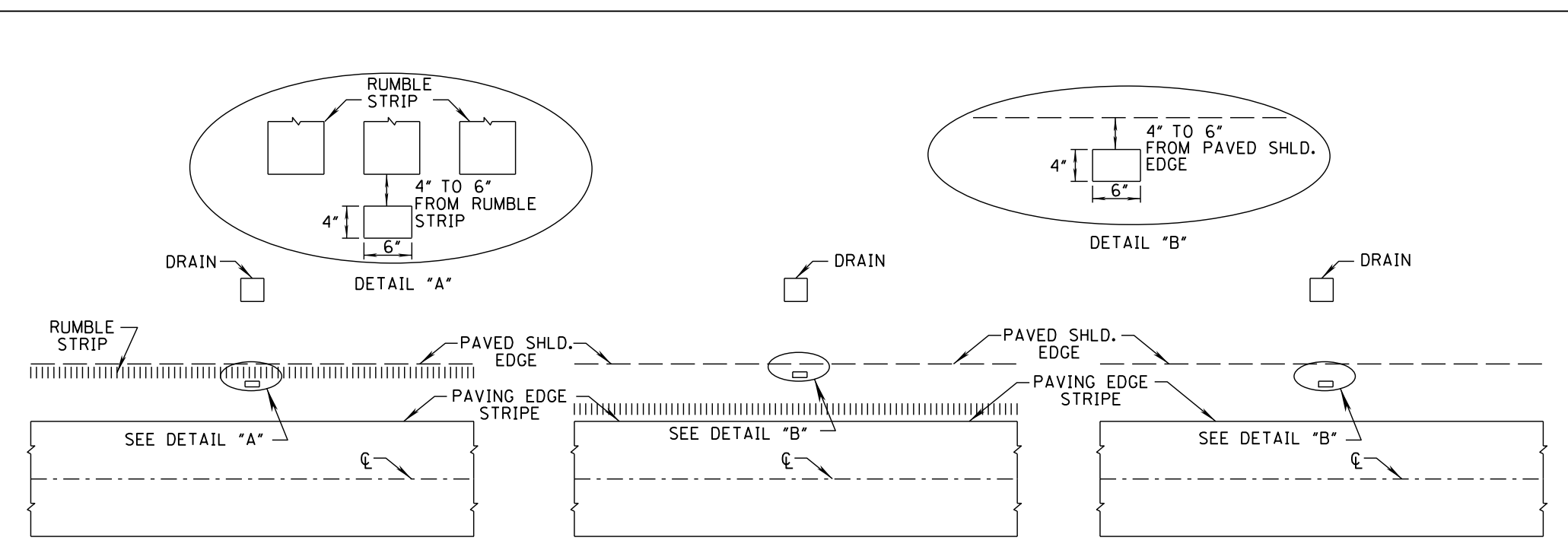

EDGE DRAIN MARKING DETAIL

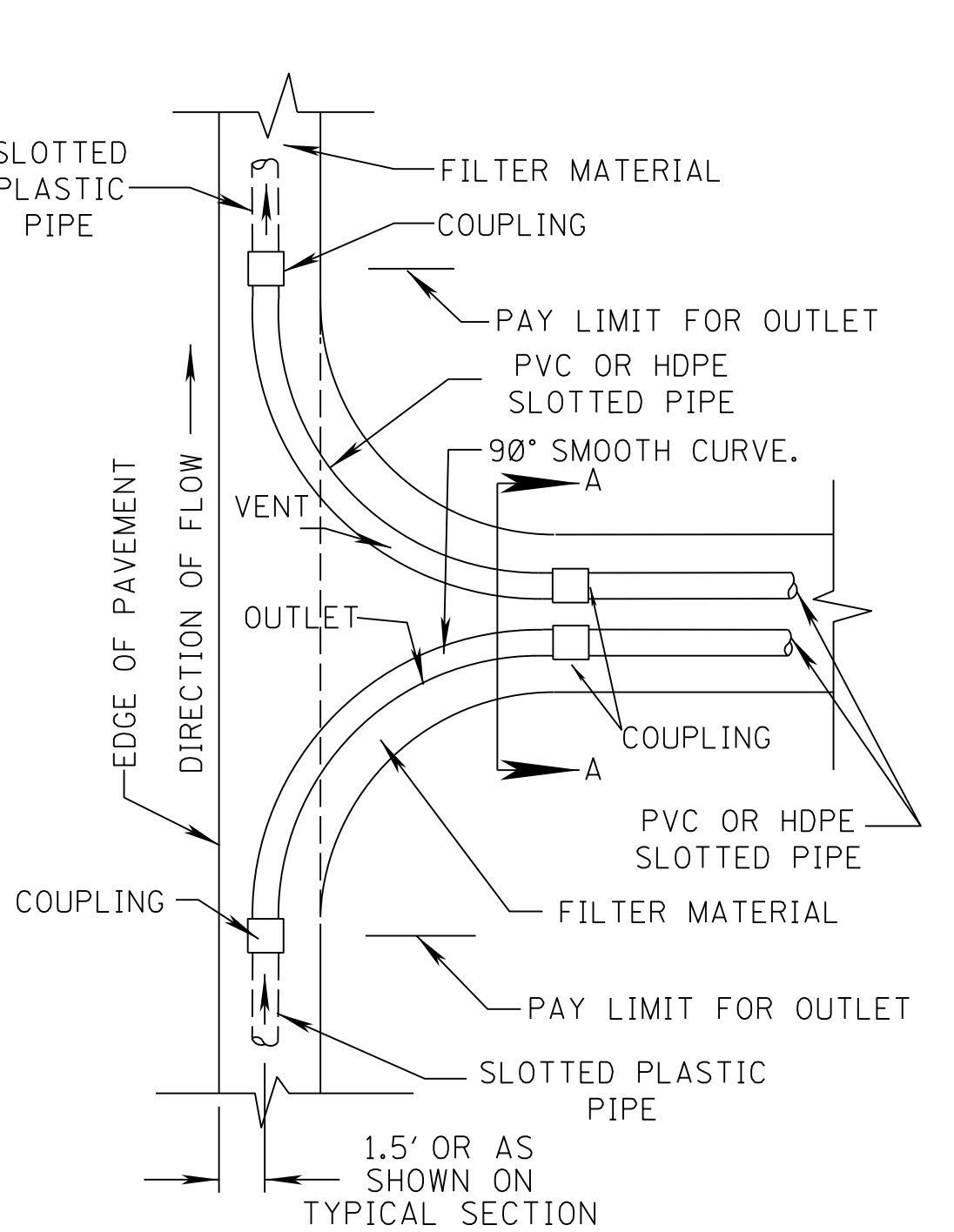

OUTLET AND VENT CONNECTION PLAN VIEW (SEE NOTE 2)

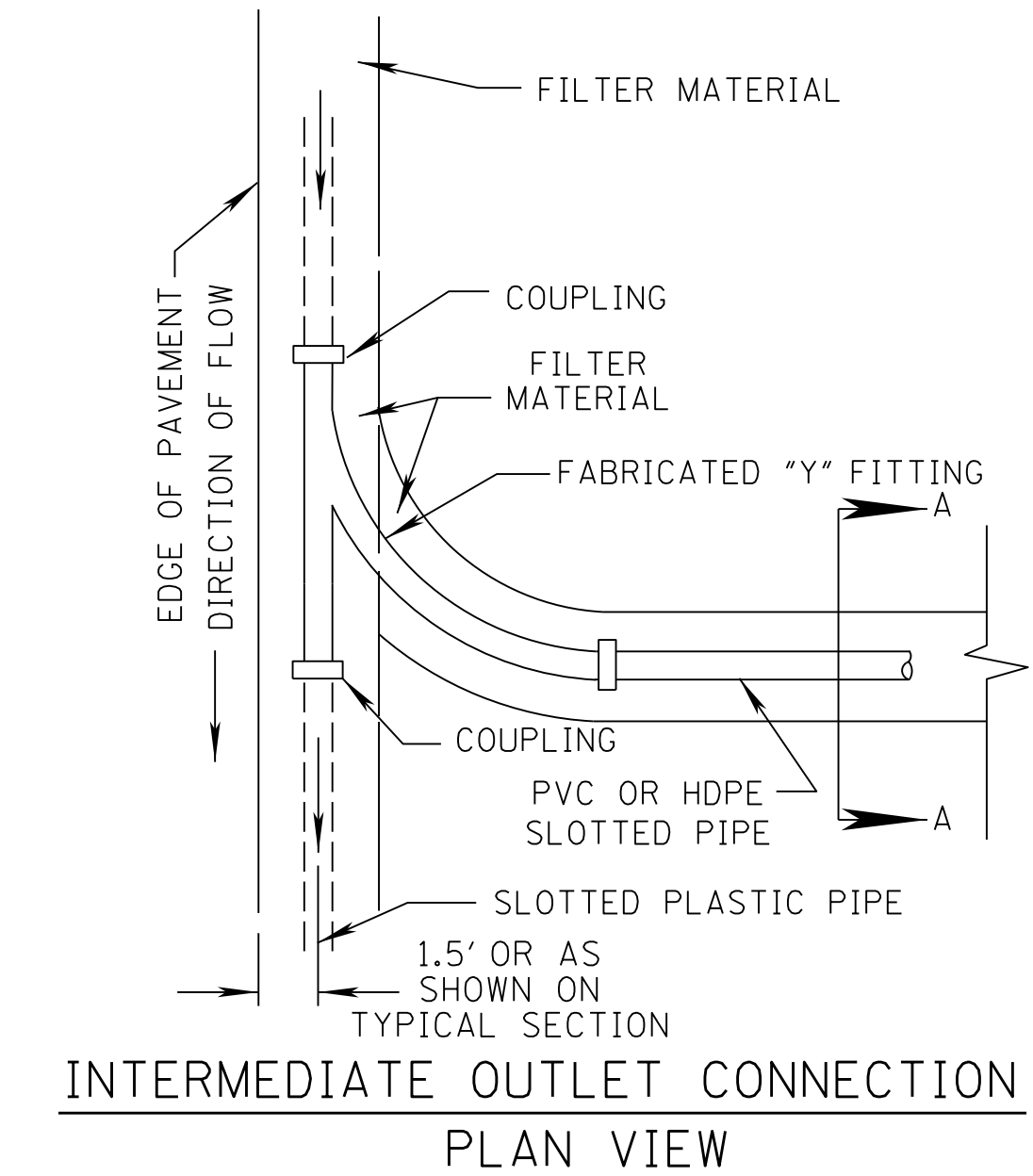

INTERMEDIATE OUTLET CONNECTION PLAN VIEW

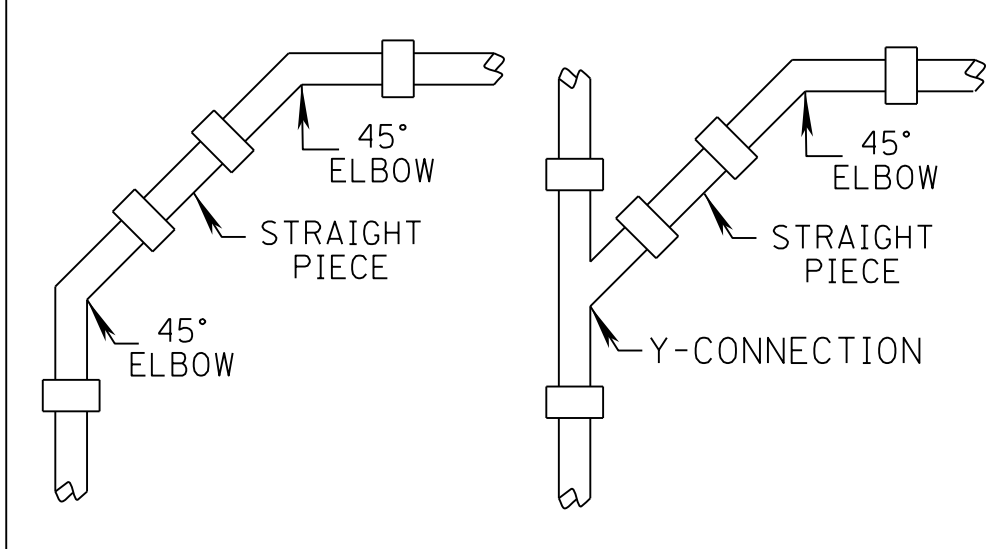

OTHER PERMISSIBLE CONNECTIONS

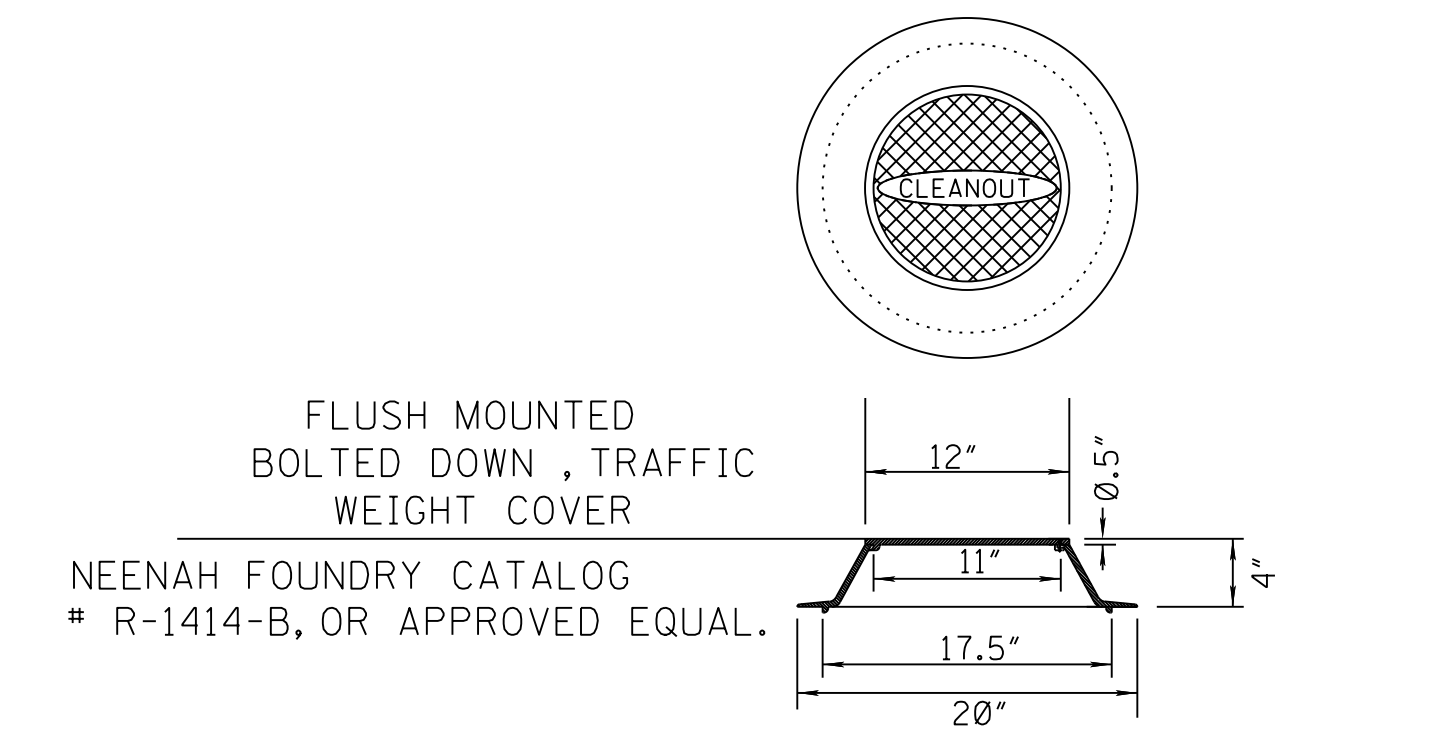

CLEANOUT ASSEMBLY DETAIL (SEE NOTE 1)

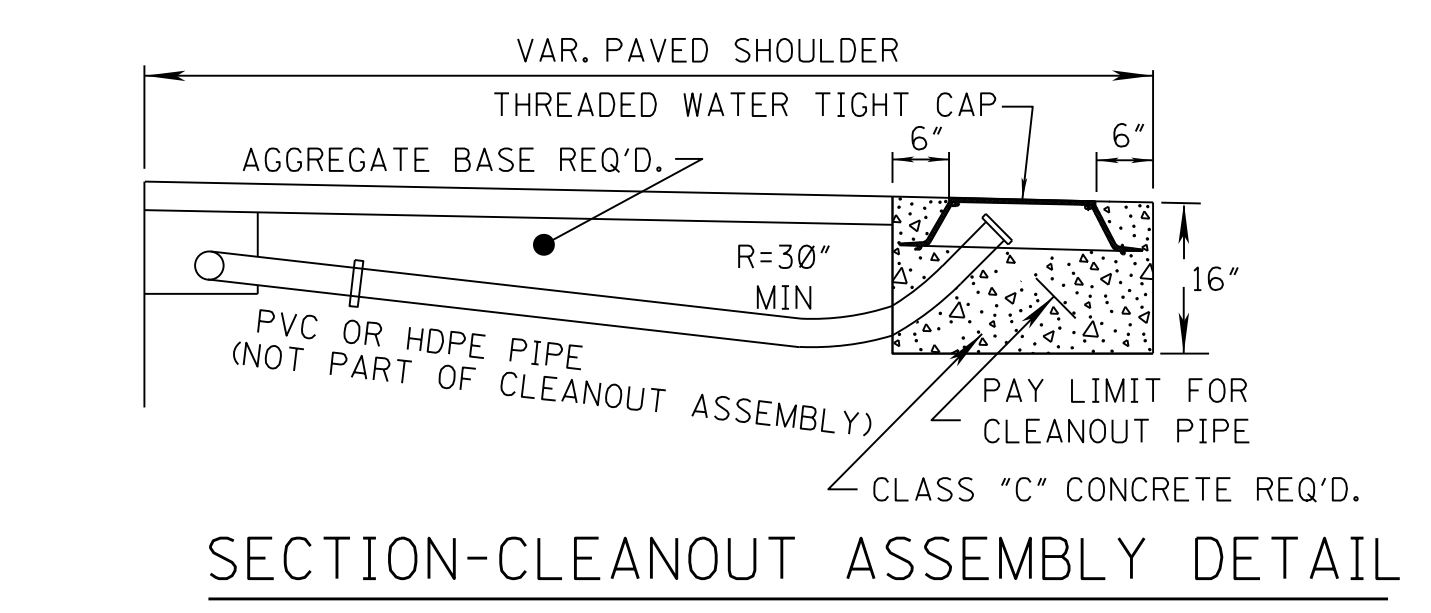

SECTION-CLEANOUT ASSEMBLY DETAIL

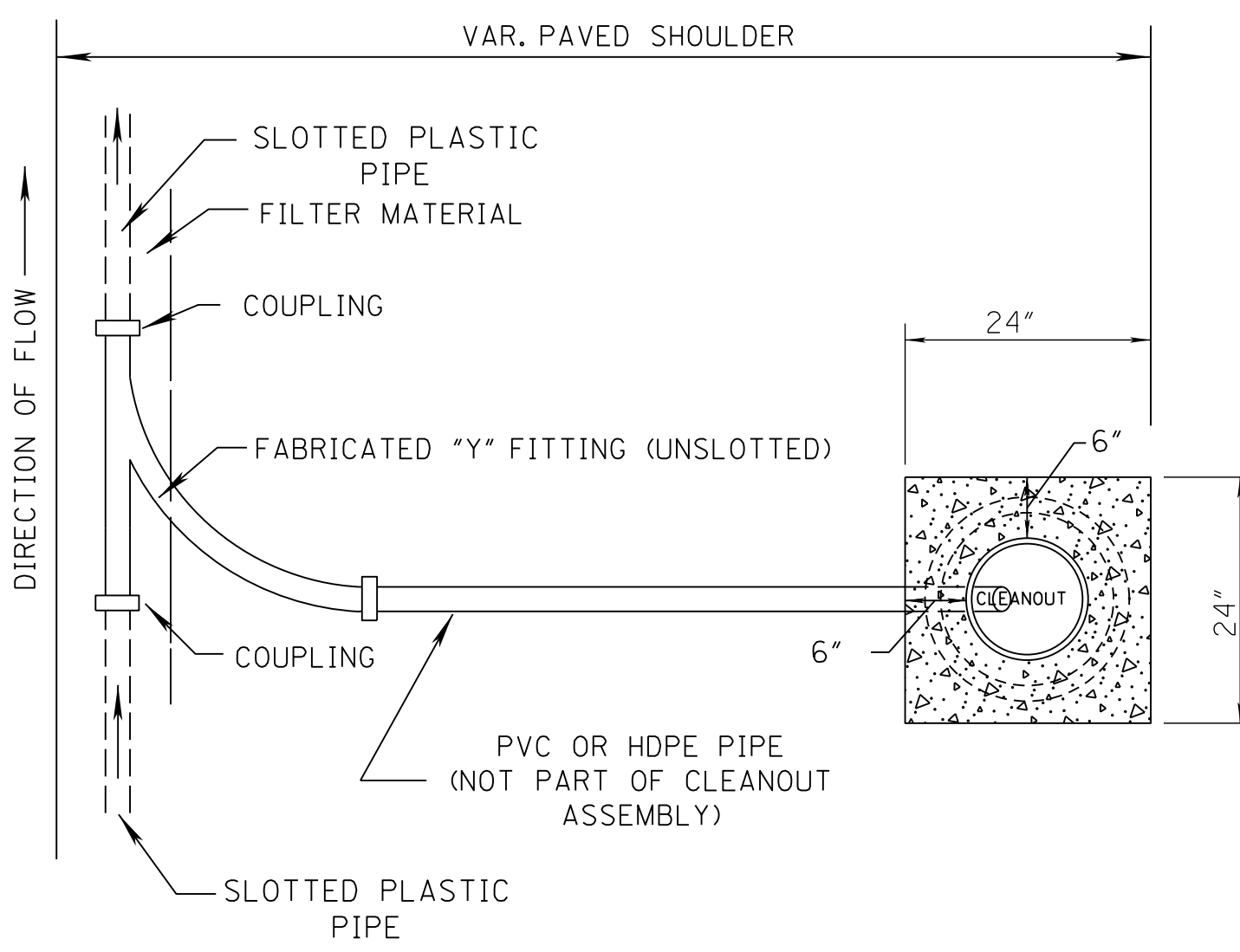

PLAN-CLEANOUT ASSEMBLY DETAIL

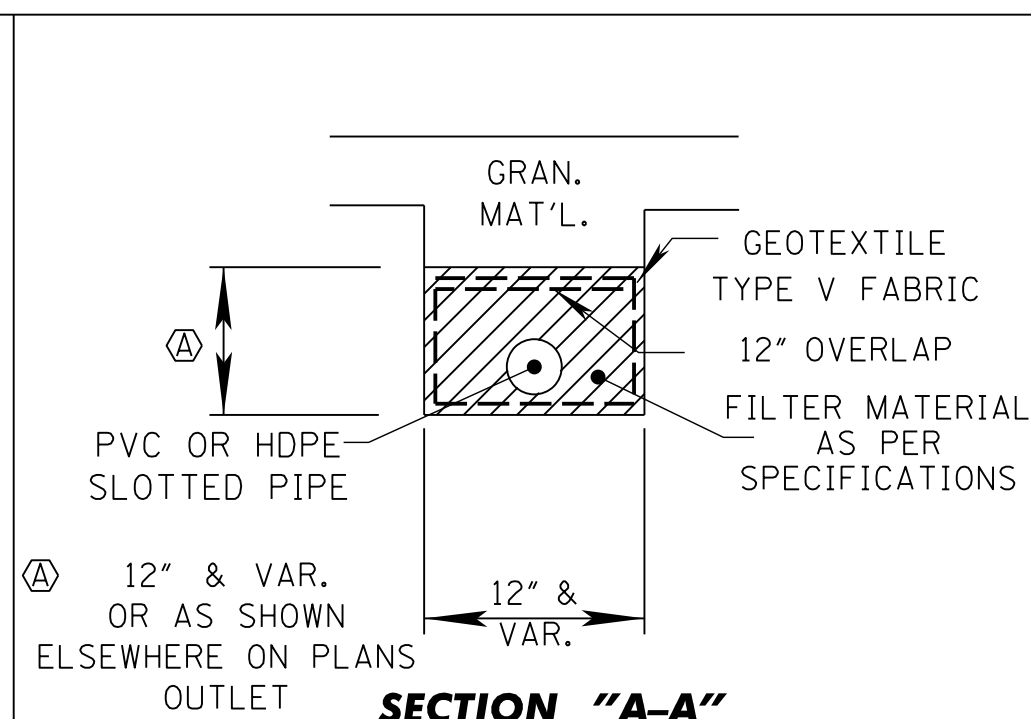

SECTION "A-A"

NOTES

- CLEANOUT ASSEMBLY ONLY TO BE USED WHEN CLEANOUT PROCEDURES CANNOT BE PERFORMED THROUGH NORMAL VENT & OUTLET INSTALLATIONS. MINIMUM DIMENSIONS ARE SHOWN FOR CLEANOUTS ASSEMBLY. TRAFFIC WEIGHT COVER SHALL HAVE TWO SCREWS OR ONE SCREW AND RETAINING LUG. CLEANOUT ASSEMBLY TO BE INSTALLED AT THE DIRECTION OF THE ENGINEER. COST OF CASTING TO BE ABSORBED IN OTHER ITEMS
- DETAILS SHOWN ALSO APPLY TO DUAL OUTLET OR DUAL VENTING INSTALLATIONS.
- PVC PIPE SHALL BE EITHER SCHEDULE 40 OR SCHEDULE 80 POLYVINYL CHLORIDE PLASTIC PIPE.
- THE CONTRACT UNIT PRICES PAID FOR EDGE DRAIN AND EDGE DRAIN OUTLETS/VENTS SHALL BE FULL COMPENSATION FOR FURNISHING ALL LABOR, MATERIALS, TOOLS, EQUIPMENT, AND INCIDENTALS AND FOR DOING ALL THE WORK INVOLVED IN CONSTRUCTING EDGE DRAINS AND EDGE DRAIN OUTLETS/VENTS COMPLETE IN PLACE, INCLUDING WIRE MESH COVERS, PIPE AND PIPE FITTINGS, COUPLINGS, UNTREATED PERMEABLE MATERIAL, GEOTEXTILE FABRIC, GRANULAR MATERIAL, BITUMINOUS PAVEMENT MIXTURE, TRENCHING, DISPOSAL OF TRENCHED MATERIALS AND OTHER MISCELLANEOUS APPURTENANCES AS SHOWN ON THE PLANS AND AS SPECIFIED IN THE STANDARD SPECIFICATIONS AND IN THIS SPECIAL PROVISION.
- 0.20 S.Y. CLASS "C" CONCRETE REQUIRED FOR CLEANOUT ASSEMBLY. TO BE PAID FOR AS PAVED DITCH
- SMALL ANIMAL GUARDS SHALL BE REQUIRED ON ALL EXPOSED PIPE OPENINGS BY THE END OF THE WORK DAY INSTALLED. PAYMENTS ASSOCIATED WITH TEMPORARY GUARDS SHALL BE INCLUDED IN THE CONTRACT UNIT PRICE FOR EDGE DRAIN OUTLETS/VENTS
- AN OUTLET OR VENT SHALL BE REQUIRED AT THE BEGINNING AND AT THE END OF EACH RUN OF EDGE DRAIN.
- FOR MORE DETAILS SEE SHEET EDO-1
- ALL FITTINGS AND JOINTS TO BE CONSTRUCTED WITH SMOOTH INTERIOR WALLS.
- EDGE DRAIN MARKER IS REQUIRED AT ALL EDGE DRAIN OUTLETS & VENTS. THE MARKER SHALL BE MADE WITH A PREFORMED TYPE OF PLASTIC TRAFFIC TAPE. ALL TAPE TO BE WHITE, SELF ADHESIVE, MINIMUM OF 4" WIDE AND 6" LONG, AND ROLLED WITH VEHICLE TIRE. COST OF MARKER TO BE ABSORBED IN OTHER ITEMS.

ALL DIMENSIONS ARE IN mm EXCEPT WHERE NOTED

MISSISSIPPI DEPARTMENT OF TRANSPORTATION

DETAIL OF EDGE DRAINS

PROJ. NO.: HSIP-0055-02(250)
COUNTY: COPIAH, HOLMES, CARROLL

DATE	DESIGN TEAM	GUEST	CHECKED	MM	DATE	7/18/19
------	-------------	-------	---------	----	------	---------

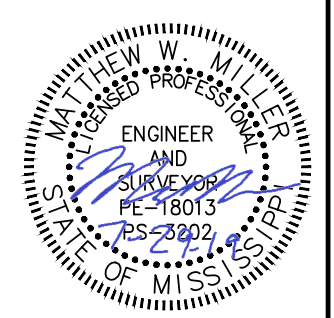

WORKING NUMBER	EDO-2
SHEET NUMBER	48

STATE	PROJECT NO.
MISS.	HSIP-0055-02(250)

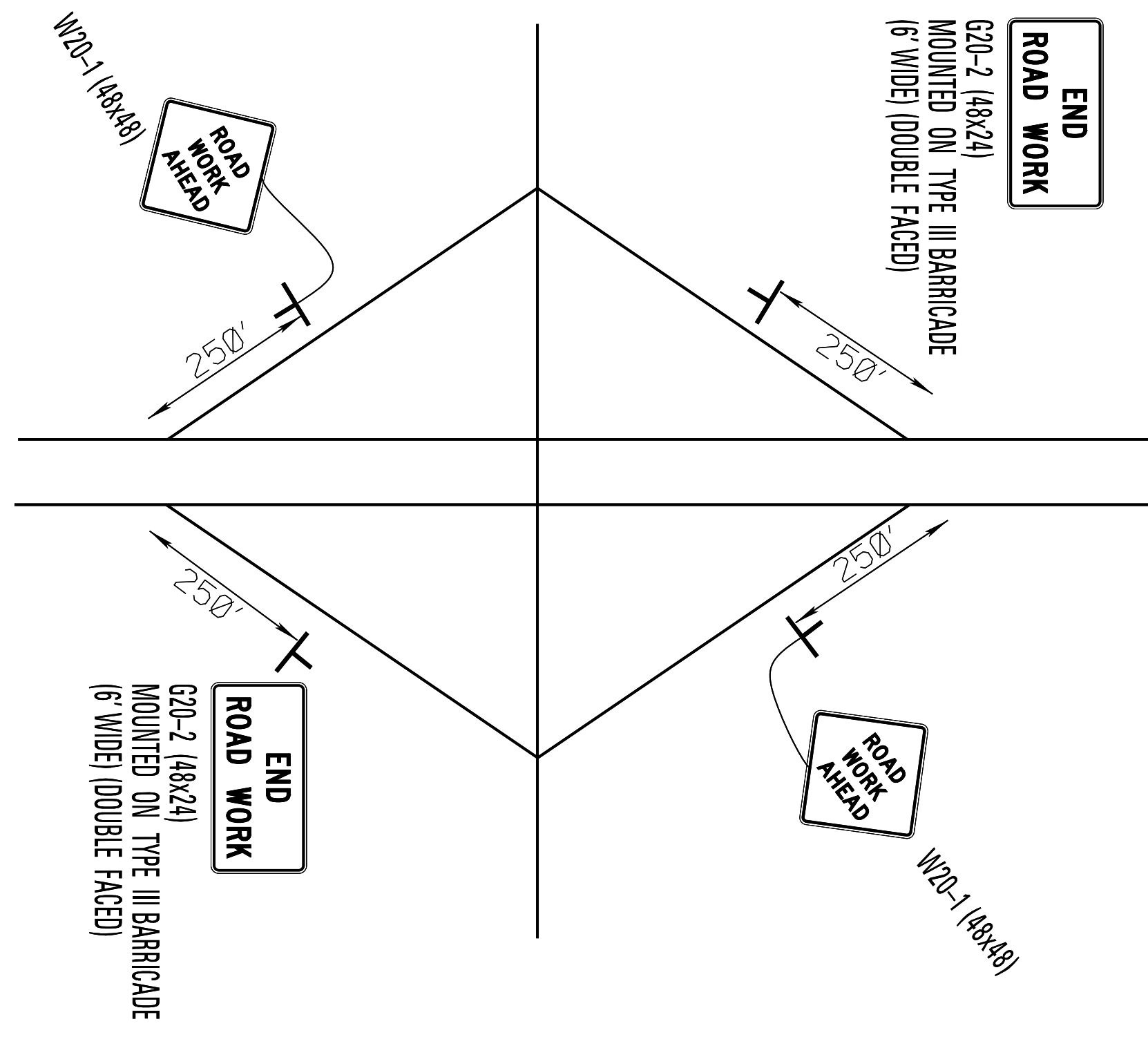
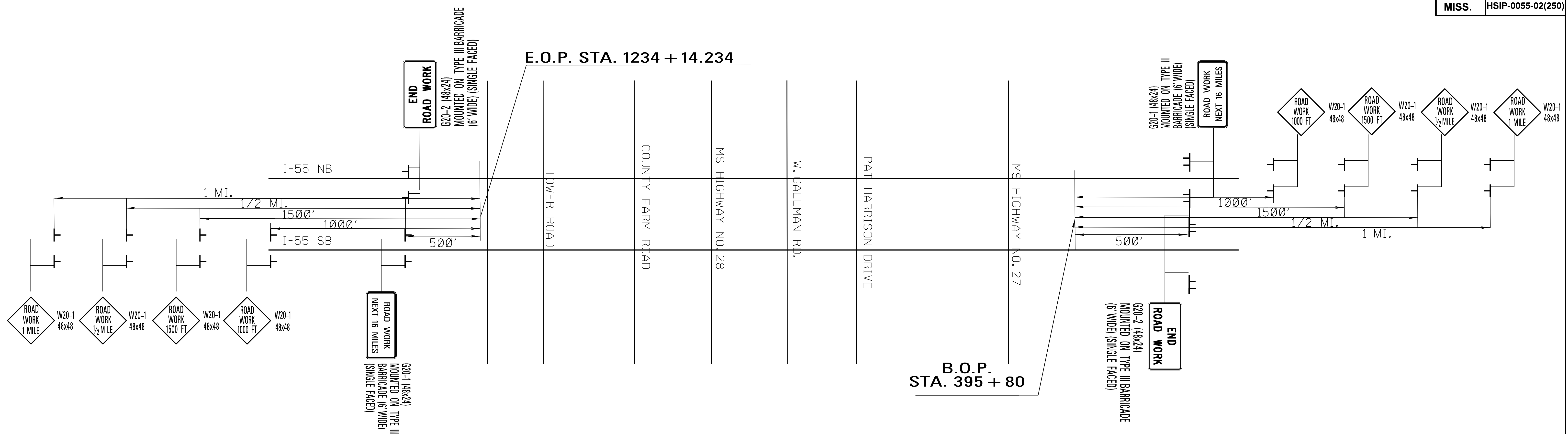

TYPICAL INTERCHANGE DETAIL
N.T.S.

INTERSECTIONS
TOWER ROAD
COUNTRY FARM RD
MS HIGHWAY 28
W. GALLMAN RD
PAT HARRISON DRIVE
MS HIGHWAY 27

MISSISSIPPI DEPARTMENT OF TRANSPORTATION	
SECTION 1,2,3,4	
PROJ. NO.: HSIP-0055-02(250) COUNTY: COPIAH	
WORKING NUMBER TC-1	SHEET NUMBER 49
DATE	FILENAME: dcs.dgn
DESIGN TEAM	GUEST CHECKED MM DATE 7/8/19

7/29/2019 4:37 PM DCS.dgn PLAN DIVISION ROADWAY MISSISSIPPI DEPARTMENT OF TRANSPORTATION

STATE	PROJECT NO.
MISS.	HSIP-0055-02(250)

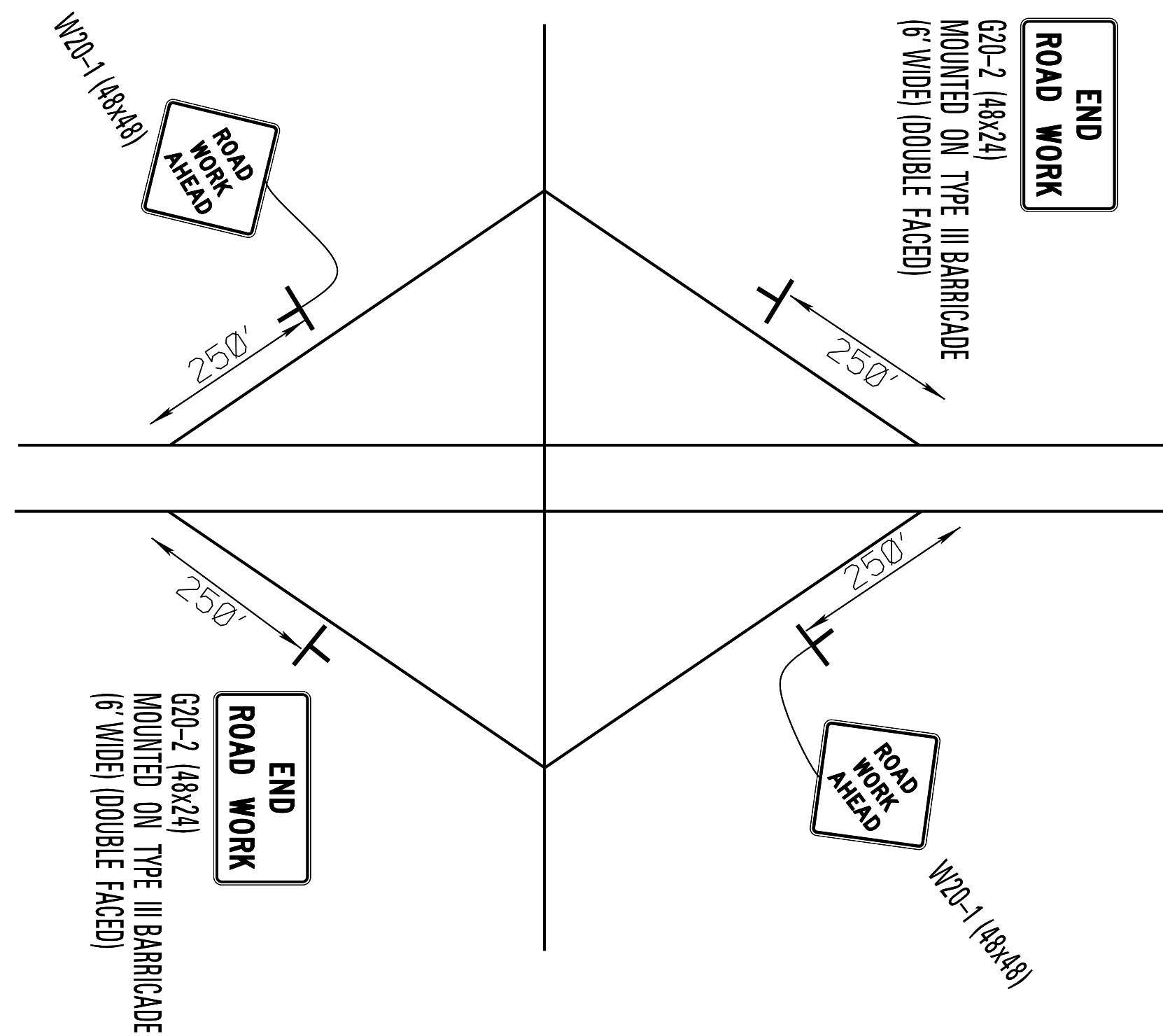
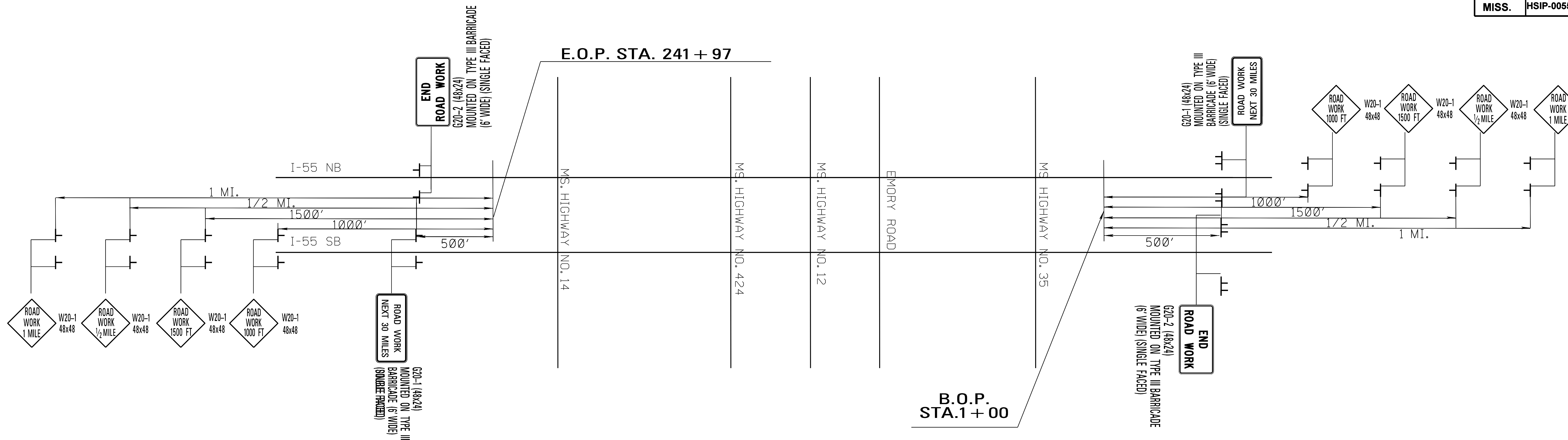

TYPICAL INTERCHANGE DETAIL
N.T.S.

INTERSECTIONS
MS HIGHWAY NO. 14
MS HIGHWAY NO. 424
MS HWY. NO. 12
EMORY RD.
MS HIGHWAY NO. 35

MISSISSIPPI DEPARTMENT OF TRANSPORTATION	
SECTIONS 1,2,3,4,5	
PROJ. NO.: HSIP-0055-02(250) COUNTY: HOLMES / CARROLL	
WORKING NUMBER	TC-2
SHEET NUMBER	50
FILENAME: dcs.dgn	DESIGN TEAM: GUEST
DATE	CHECKED: MM DATE: 7/8/19

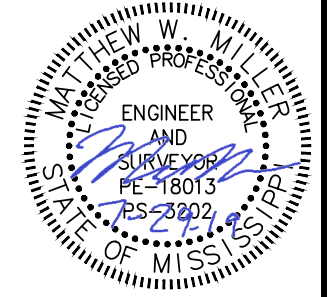

7/29/2019 4:37 PM DCS.dgn PLAN DIVISION MISSISSIPPI DEPARTMENT OF TRANSPORTATION

STATE	PROJECT NO.
MISS.	HSIP-0055-02(250)

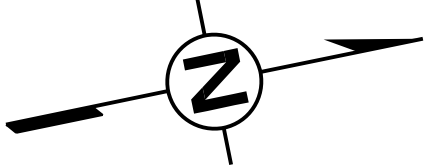

LEGEND

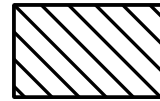
 SLOPE WORK REQ'D (6:1)

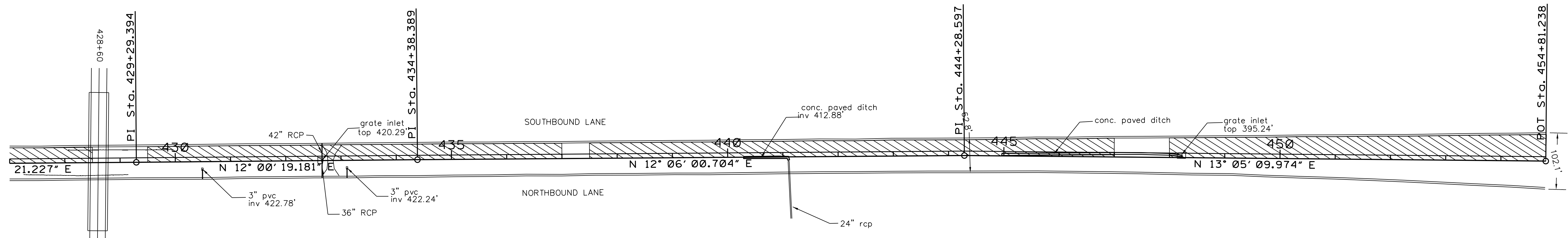
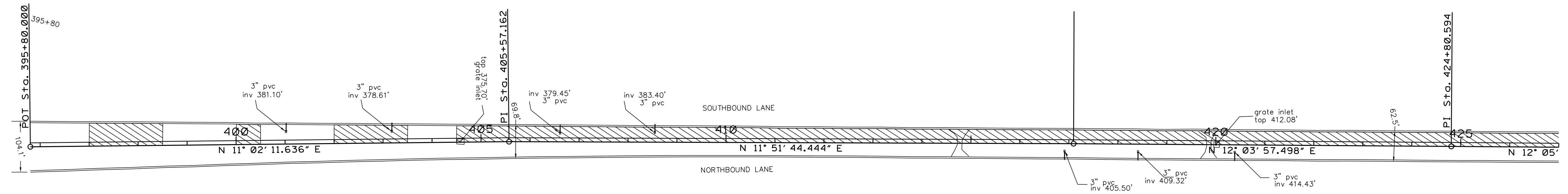

7/29/2019 4:37 PM ECP1.dgn

ROADWAY PLAN DIVISION
MISSISSIPPI DEPARTMENT OF TRANSPORTATION

TEMPORARY EROSION CONTROL ITEMS	UNITS	SYMBOL	TOTALS
SILT FENCE	L.F.	-SF-	
SUPER SILT FENCE	L.F.	-SSF-	
WATTLES, 12"	L.F.		
WATTLES, 20"	L.F.		
TRIANGULAR SILT DIKE	L.F.		
SANDBAGS	L.F.		
RIPRAP	TON		
EROSION CHECKS	BALE		
TYPE D SILT BASINS	EACH		

MISSISSIPPI DEPARTMENT OF TRANSPORTATION

**COPIAH COUNTY SECTION 1
PLAN VIEW**

PROJ. NO.: HSIP-0055-02(250)
COUNTY: COPIAH

WORKING NUMBER
ECP1
SHEET NUMBER
51

FILENAME: **ecp1.dgn**
DESIGN TEAM: **GUEST** CHECKED: **MM** DATE: **7/8/19**

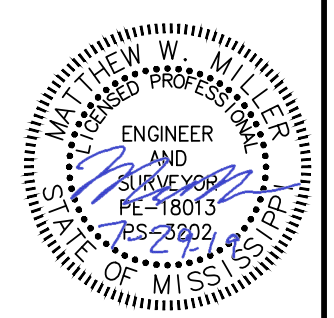



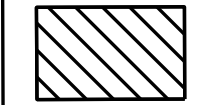

STATE	PROJECT NO.
MISS.	HSIP-0055-02(250)

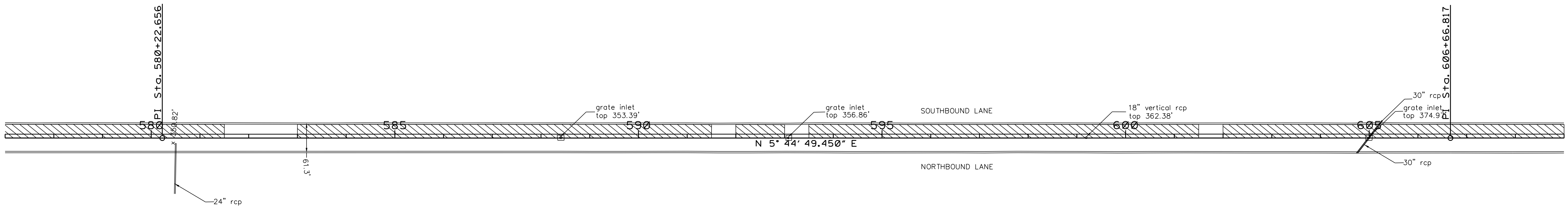
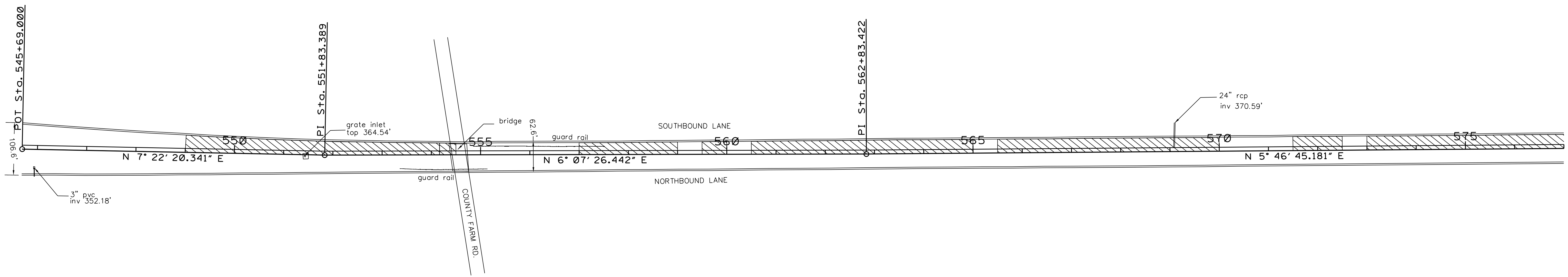
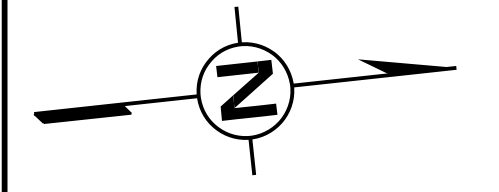
LEGEND

 SLOPE WORK REQ'D (6:1)

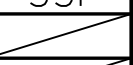
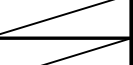
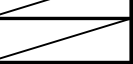

7/29/2019 4:37 PM ECP2.DGN

TEMPORARY EROSION CONTROL ITEMS	UNITS	SYMBOL	TOTALS
SILT FENCE	L.F.	—SF—	
SUPER SILT FENCE	L.F.	—SSF—	
WATTLES, 12"	L.F.		
WATTLES, 20"	L.F.		
TRIANGULAR SILT DIKE	L.F.		
SANDBAGS	L.F.		
RIPRAP	TON		
EROSION CHECKS	BALE		
TYPE D SILT BASINS	EACH		

MISSISSIPPI DEPARTMENT OF TRANSPORTATION

**COPIAH COUNTY SECTION 2
PLAN VIEW**

PROJ. NO.: HSIP-0055-02(250)
COUNTY: COPIAH

ENGINEER AND SURVEYOR
JAMES W. WILLIAMS
PE #8013
PS 2002
STATE OF MISSISSIPPI

WORKING NUMBER
ECP2
SHEET NUMBER
52

FILENAME: **ecp2.dgn**
DESIGN TEAM: GUEST CHECKED: MM DATE: 7/8/19

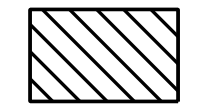

STATE	PROJECT NO.
MISS.	HSIP-0055-02(250)

LEGEND

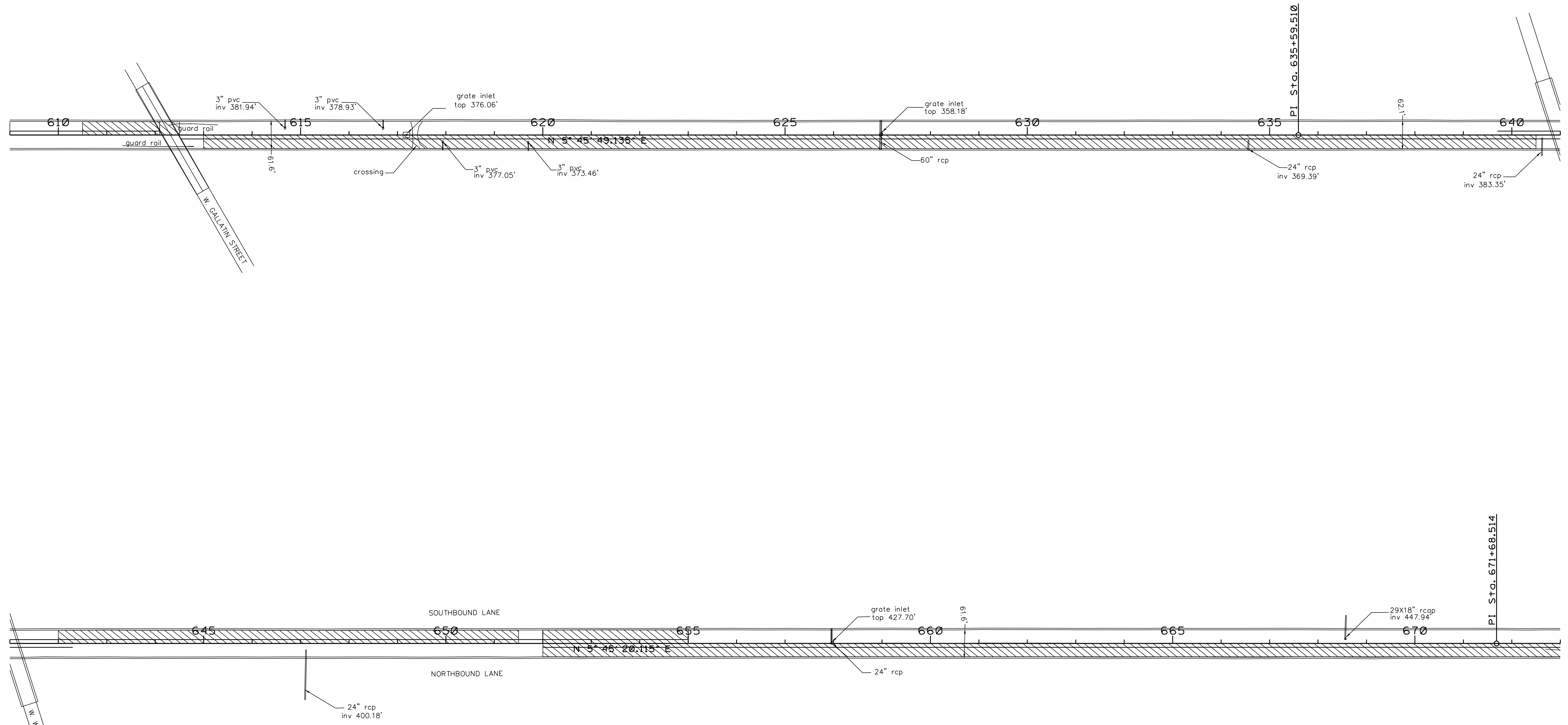
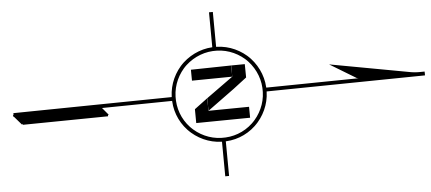
 SLOPE WORK REQ'D (6:1)

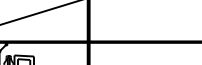

7/29/2019 4:37 PM ECP3.DGN PLAN DIVISION MISSISSIPPI DEPARTMENT OF TRANSPORTATION

TEMPORARY EROSION CONTROL ITEMS	UNITS	SYMBOL	TOTALS
SILT FENCE	L.F.	—SF—	
SUPER SILT FENCE	L.F.	—SSF—	
WATTLES, 12"	L.F.		
WATTLES, 20"	L.F.		
TRIANGULAR SILT DIKE	L.F.		
SANDBAGS	L.F.		
RIPRAP	TON		
EROSION CHECKS	BALE		
TYPE D SILT BASINS	EACH		

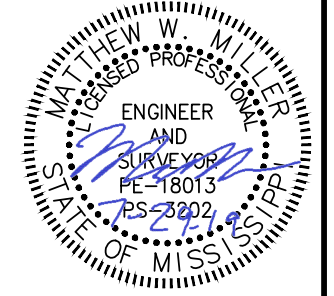



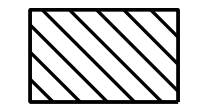

MISSISSIPPI DEPARTMENT OF TRANSPORTATION	
COPIAH COUNTY SECTION 2 PLAN VIEW	
	
PROJ. NO.: HSIP-0055-02(250) COUNTY: COPIAH	
WORKING NUMBER ECP3	SHEET NUMBER 53
FILENAME: _ecp3.dgn DESIGN TEAM: GUEST CHECKED: MM DATE: 7/8/19	

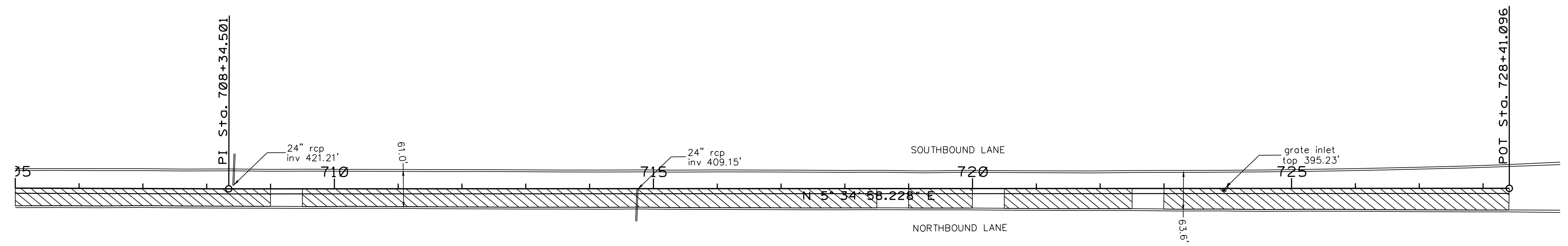
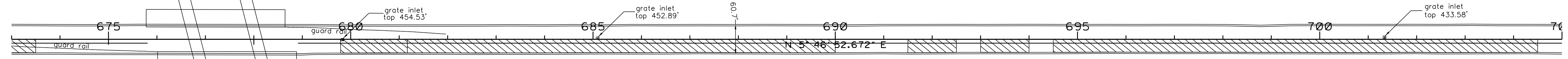
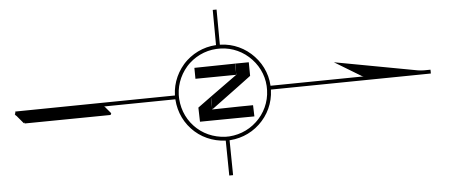
STATE	PROJECT NO.
MISS.	HSIP-0055-02(250)

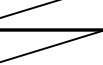
LEGEND

 SLOPE WORK REQ'D (6:1)

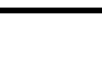

TEMPORARY EROSION CONTROL ITEMS	UNITS	SYMBOL	TOTALS
SILT FENCE	L.F.	—SF—	
SUPER SILT FENCE	L.F.	—SSF—	
WATTLES, 12"	L.F.		
WATTLES, 20"	L.F.		
TRIANGULAR SILT DIKE	L.F.		
SANDBAGS	L.F.		
RIPRAP	TON		
EROSION CHECKS	BALE		
TYPE D SILT BASINS	EACH		

MISSISSIPPI DEPARTMENT OF TRANSPORTATION

**COPIAH COUNTY SECTION 2
PLAN VIEW**

PROJ. NO.: HSIP-0055-02(250)
COUNTY: COPIAH

WORKING NUMBER
ECP4

SHEET NUMBER
54

ENGINEER AND SURVEYOR
STATE OF MISSISSIPPI

FILENAME: **ecp4.dgn**

DESIGN TEAM: GUEST CHECKED: MM DATE: 7/8/19

7/29/2019 4:37 PM ECP4.DGN

STATE	PROJECT NO.
MISS.	HSIP-0055-02(250)

LEGEND

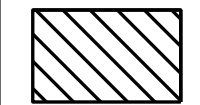
 SLOPE WORK REQ'D (6:1)

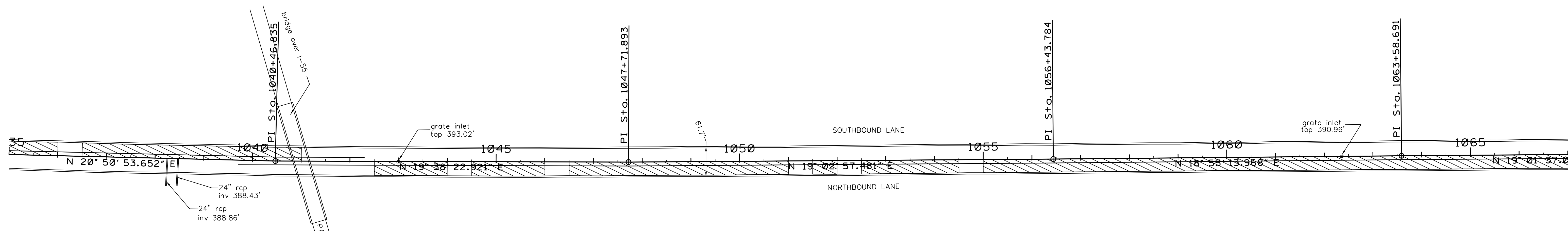
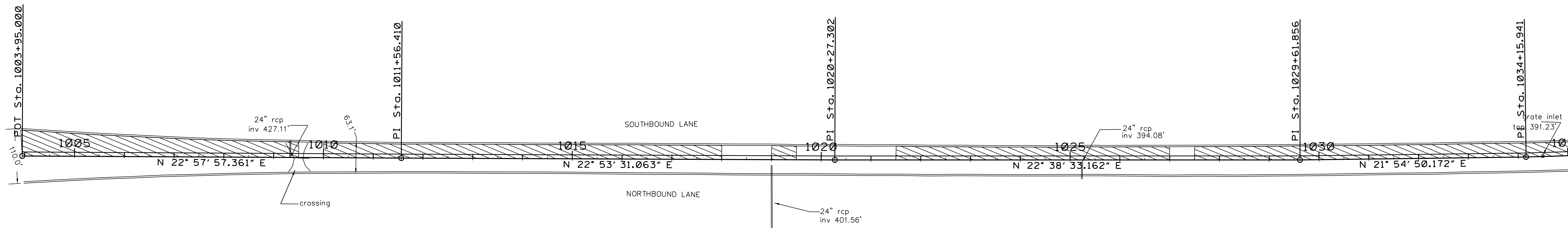
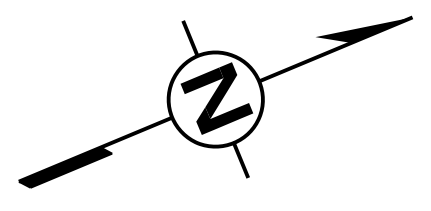

TEMPORARY EROSION CONTROL ITEMS	UNITS	SYMBOL	TOTALS
SILT FENCE	L.F.	—SF—	
SUPER SILT FENCE	L.F.	—SSF—	
WATTLES, 12"	L.F.		
WATTLES, 20"	L.F.		
TRIANGULAR SILT DIKE	L.F.		
SANDBAGS	L.F.		
RIPRAP	TON		
EROSION CHECKS	BALE		
TYPE D SILT BASINS	EACH		

MISSISSIPPI DEPARTMENT OF TRANSPORTATION

**COPIAH COUNTY SECTION 3
PLAN VIEW**

PROJ. NO.: HSIP-0055-02(250)
COUNTY: COPIAH

ENGINEER AND SURVEYOR
W. W. WILSON
PE 18013
RS 2802
STATE OF MISSISSIPPI

WORKING NUMBER
ECP5
SHEET NUMBER
55

FILENAME: ecp5.dgn

DESIGN TEAM: GUEST CHECKED: MM DATE: 7/8/19

PLAN DIVISION
MISSISSIPPI DEPARTMENT OF TRANSPORTATION

7/29/2019 4:37 PM ECP5.DGN

STATE	PROJECT NO.
MISS.	HSIP-0055-02(250)

LEGEND

 SLOPE WORK REQ'D (6:1)

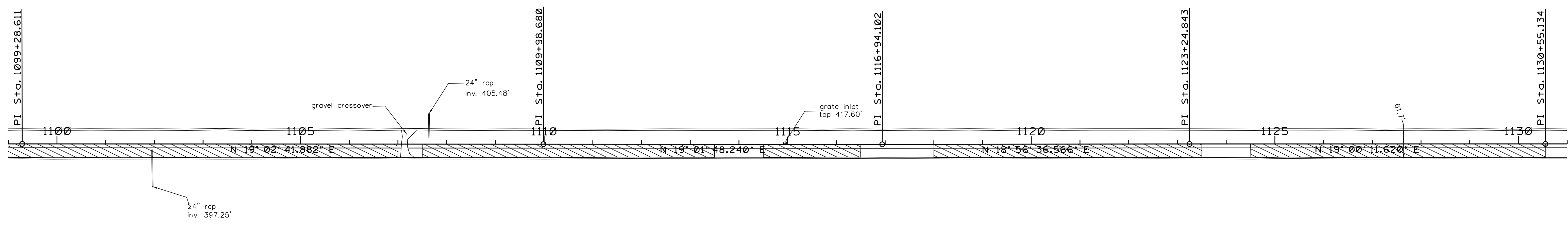
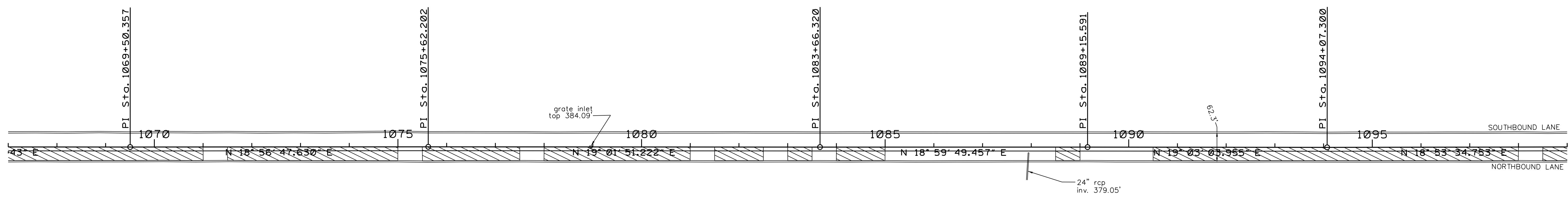
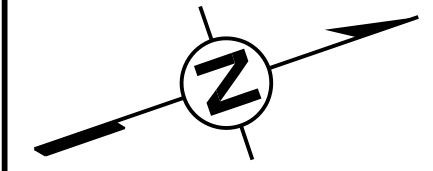

TEMPORARY EROSION CONTROL ITEMS	UNITS	SYMBOL	TOTALS
SILT FENCE	L.F.	—SF—	
SUPER SILT FENCE	L.F.	—SSF—	
WATTLES, 12"	L.F.		
WATTLES, 20"	L.F.		
TRIANGULAR SILT DIKE	L.F.		
SANDBAGS	L.F.		
RIPRAP	TON		
EROSION CHECKS	BALE		
TYPE D SILT BASINS	EACH		

MISSISSIPPI DEPARTMENT OF TRANSPORTATION

**COPIAH COUNTY SECTION 3
PLAN VIEW**

PROJ. NO.: HSIP-0055-02(250)
COUNTY: COPIAH

WORKING NUMBER
ECP6
SHEET NUMBER
56

FILENAME: **ecp6.dgn**

DESIGN TEAM: GUEST CHECKED: MM DATE: 7/8/19

REVISION: BY: DATE

DATE: BY: DATE:

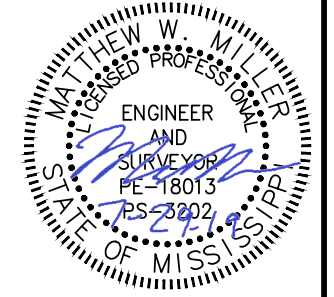

ROADWAY PLAN DIVISION MISSISSIPPI DEPARTMENT OF TRANSPORTATION

7/29/2019 4:37 PM ECP6.DGN

STATE	PROJECT NO.
MISS.	HSIP-0055-02(250)

LEGEND

 SLOPE WORK REQ'D (6:1)

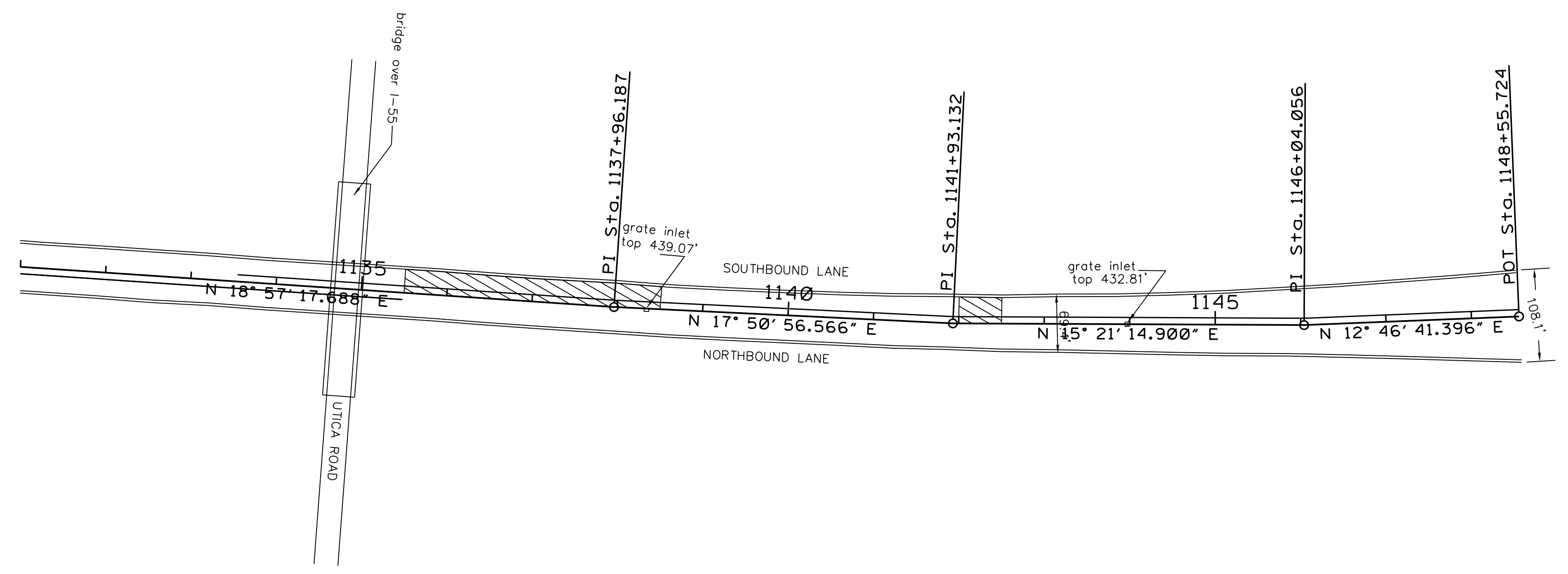
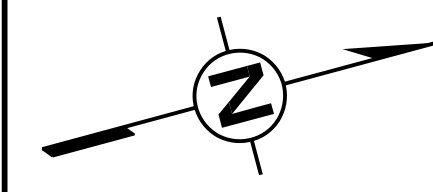

7/29/2019 4:37 PM ECP7.dgn

TEMPORARY EROSION CONTROL ITEMS	UNITS	SYMBOL	TOTALS
SILT FENCE	L.F.	—SF—	
SUPER SILT FENCE	L.F.	—SSF—	
WATTLES, 12"	L.F.		
WATTLES, 20"	L.F.		
TRIANGULAR SILT DIKE	L.F.		
SANDBAGS	L.F.		
RIPRAP	TON	███	
EROSION CHECKS	BALE		
TYPE D SILT BASINS	EACH	⊗	

MISSISSIPPI DEPARTMENT OF TRANSPORTATION	
COPIAH COUNTY SECTION 3 PLAN VIEW	
PROJ. NO.: HSIP-005-02(250) COUNTY: COPIAH	
DATE	WORKING NUMBER
DESIGN TEAM	ECP7
CHECKED	SHEET NUMBER
DATE	57

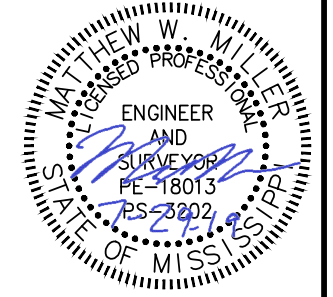



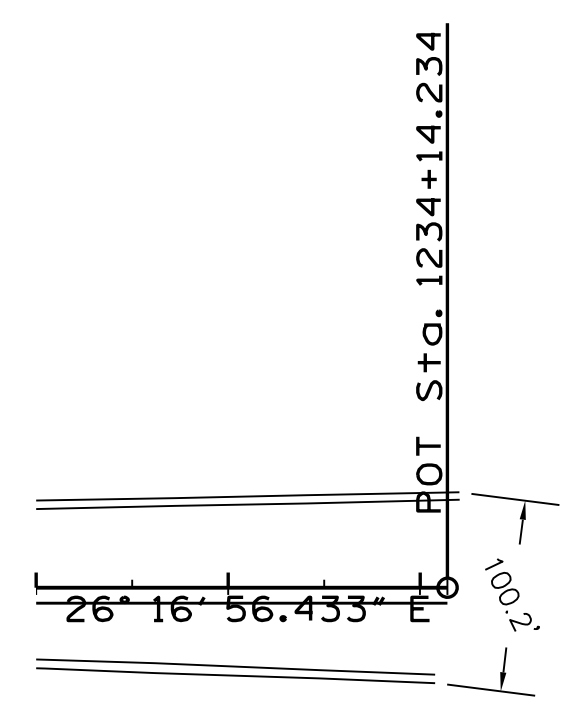
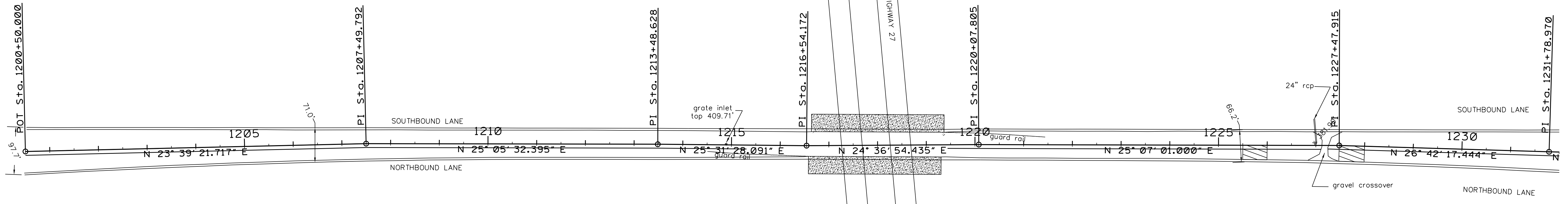
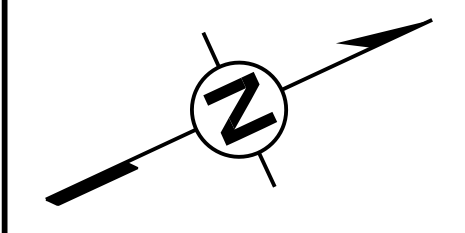

STATE	PROJECT NO.
MISS.	HSIP-0055-02(250)

LEGEND

 SLOPE WORK REQ'D (6:1)

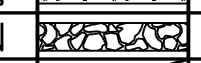
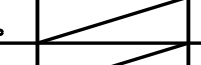
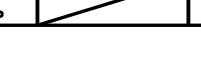

PERMANENT EROSION CONTROL ITEMS	UNITS	SYMBOL	TOTALS
DITCH LINER	S.Y.		
SOIL REINF. MATERIAL	S.Y.		
PAVED DITCH	C.Y.		
RIPRAP	TON		
GEOTEXTILE	S.Y.		
SOLID SOD	S.Y.		

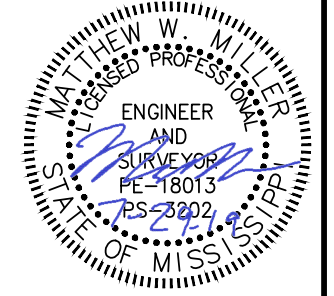
MISSISSIPPI DEPARTMENT OF TRANSPORTATION	
COPIAH COUNTY SECTION 4 PLAN VIEW	
	
PROJ. NO.: HSIP-0055-02(250) COUNTY: COPIAH	
WORKING NUMBER ECP8	SHEET NUMBER 58
FILENAME: ecp8.dgn DESIGN TEAM: GUEST CHECKED: MM DATE: 7/8/19	

STATE	PROJECT NO.
MISS.	HSIP-0055-02(250)

LEGEND

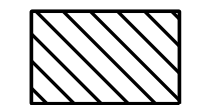
 SLOPE WORK REQ'D (6:1)

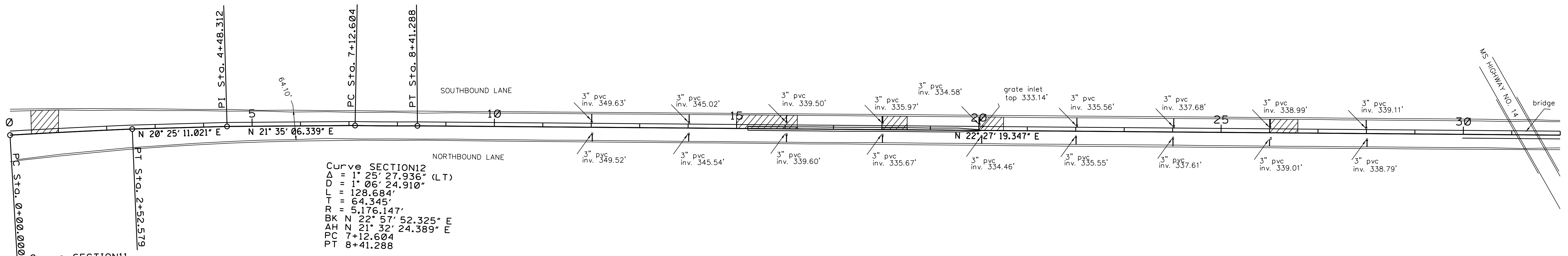
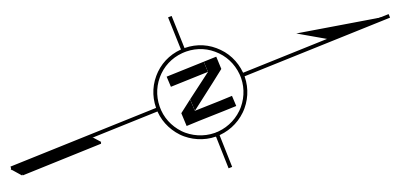

Curve SECTION11
 $\Delta = 0^{\circ} 55' 59.955''$ (RT)
 $D = 0^{\circ} 22' 10.261''$
 $L = 252.579'$
 $T = 126.292'$
 $R = 15,505.594'$
 BK N $18^{\circ} 40' 21.919''$ E
 AH N $19^{\circ} 36' 21.875''$ E
 PC 0+00.000
 PT 2+52.579

Curve SECTION14
 $\Delta = 0^{\circ} 31' 33.618''$ (LT)
 $D = 0^{\circ} 22' 54.175''$
 $L = 137.800'$
 $T = 68.901'$
 $R = 15,010.083'$
 BK N $22^{\circ} 45' 59.808''$ E
 AH N $22^{\circ} 14' 26.190''$ E
 PC 55+38.969
 PT 56+76.770

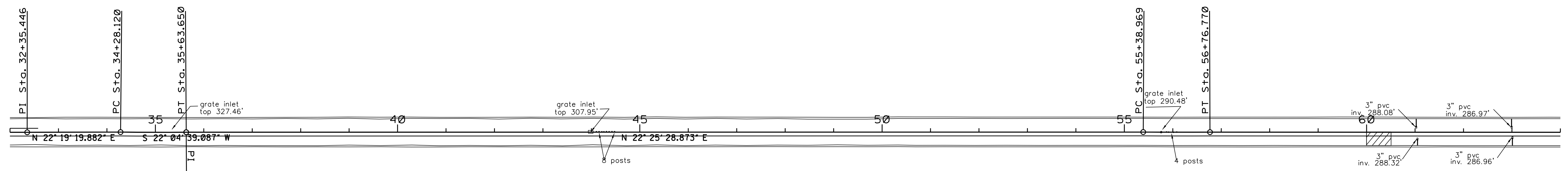

TEMPORARY EROSION CONTROL ITEMS	UNITS	SYMBOL	TOTALS
SILT FENCE	L.F.	--SF--	
SUPER SILT FENCE	L.F.	--SSF--	
WATTLES, 12"	L.F.		
WATTLES, 20"	L.F.		
TRIANGULAR SILT DIKE	L.F.		
SANDBAGS	L.F.		
RIPRAP	TON		
EROSION CHECKS	BALE		
TYPE D SILT BASINS	EACH		

MISSISSIPPI DEPARTMENT OF TRANSPORTATION

**HOLMES COUNTY SECTION 1
PLAN VIEW**

PROJ. NO.: HSIP-0055-02(250)
 COUNTY: HOLMES

FILENAME: **ecp9.dgn**

DESIGN TEAM: GUEST CHECKED: MM DATE: 7/8/19

WORKING NUMBER: **ECP9**
 SHEET NUMBER: **59**

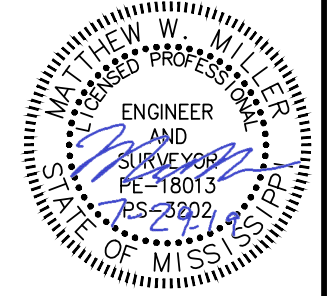

ROADWAY PLAN DIVISION MISSISSIPPI DEPARTMENT OF TRANSPORTATION

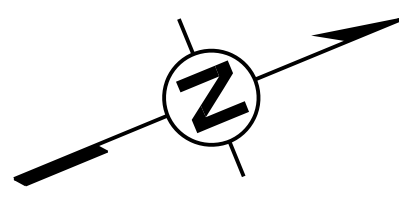

STATE	PROJECT NO.
MISS.	HISP-0055-02(250)

LEGEND

SLOPE WORK REQ'D (6:1)

Curve SECTION15
 Δ = 2° 11' 27.189" (LT)
 D = 1' 38" 55.251"
 L = 132.887'
 T = 66.452'
 R = 3,475.250'
 BK N 23° 34' 43.814" E
 AH N 21° 23' 16.625" E
 PC 84+39.323
 PT 85+72.210

IMPAIRED WATER BODY
 GREENS CREEK IS IMPAIRED
 DUE TO SEDIMENT

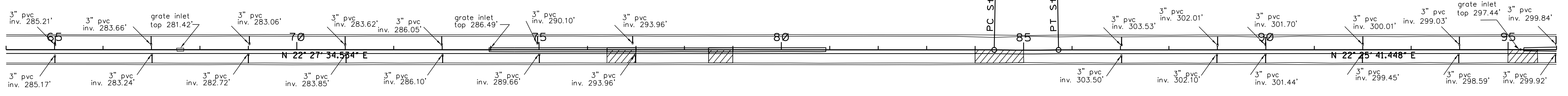

Curve SECTION16
 Δ = 0° 56' 50.532" (LT)
 D = 0° 49' 45.230"
 L = 114.247'
 T = 57.125'
 R = 6,909.511'
 BK N 23° 05' 01.973" E
 AH N 22° 08' 11.440" E
 PC 98+72.669
 PT 99+86.916

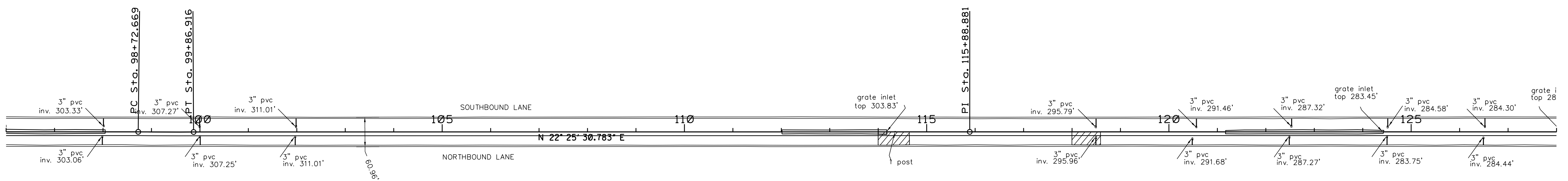

TEMPORARY EROSION CONTROL ITEMS	UNITS	SYMBOL	TOTALS
SILT FENCE	L.F.	—SF—	
SUPER SILT FENCE	L.F.	—SSF—	
WATTLES, 12"	L.F.		
WATTLES, 20"	L.F.		
TRIANGULAR SILT DIKE	L.F.		
SANDBAGS	L.F.		
RIPRAP	TON		
EROSION CHECKS	BALE		
TYPE D SILT BASINS	EACH		

MISSISSIPPI DEPARTMENT OF TRANSPORTATION

**HOLMES COUNTY SECTION 1
 PLAN VIEW**

PROJ. NO.: HSP-0055-02(250)
 COUNTY: HOLMES

FILENAME: ecp10.dgn

DESIGN TEAM: GUEST CHECKED: MM DATE: 7/8/19

WORKING NUMBER
ECP10

SHEET NUMBER
60

B:\22\2019 1:24 PM ECP10.DGN MISSISSIPPI DEPARTMENT OF TRANSPORTATION

STATE	PROJECT NO.
MISS.	HISP-0055-02(250)

LEGEND

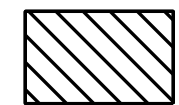
 SLOPE WORK REQ'D (6:1)

Curve SECTION17
 $\Delta = 7^{\circ} 09' 04.994''$ (LT)
 $D = 0^{\circ} 53' 01.949''$
 $L = 809.095'$
 $T = 405.074'$
 $R = 6,482.341'$
 BK N $22^{\circ} 28' 12.141''$ E
 AH N $15^{\circ} 19' 07.147''$ E
 PC 151+41.487
 PT 159+50.582

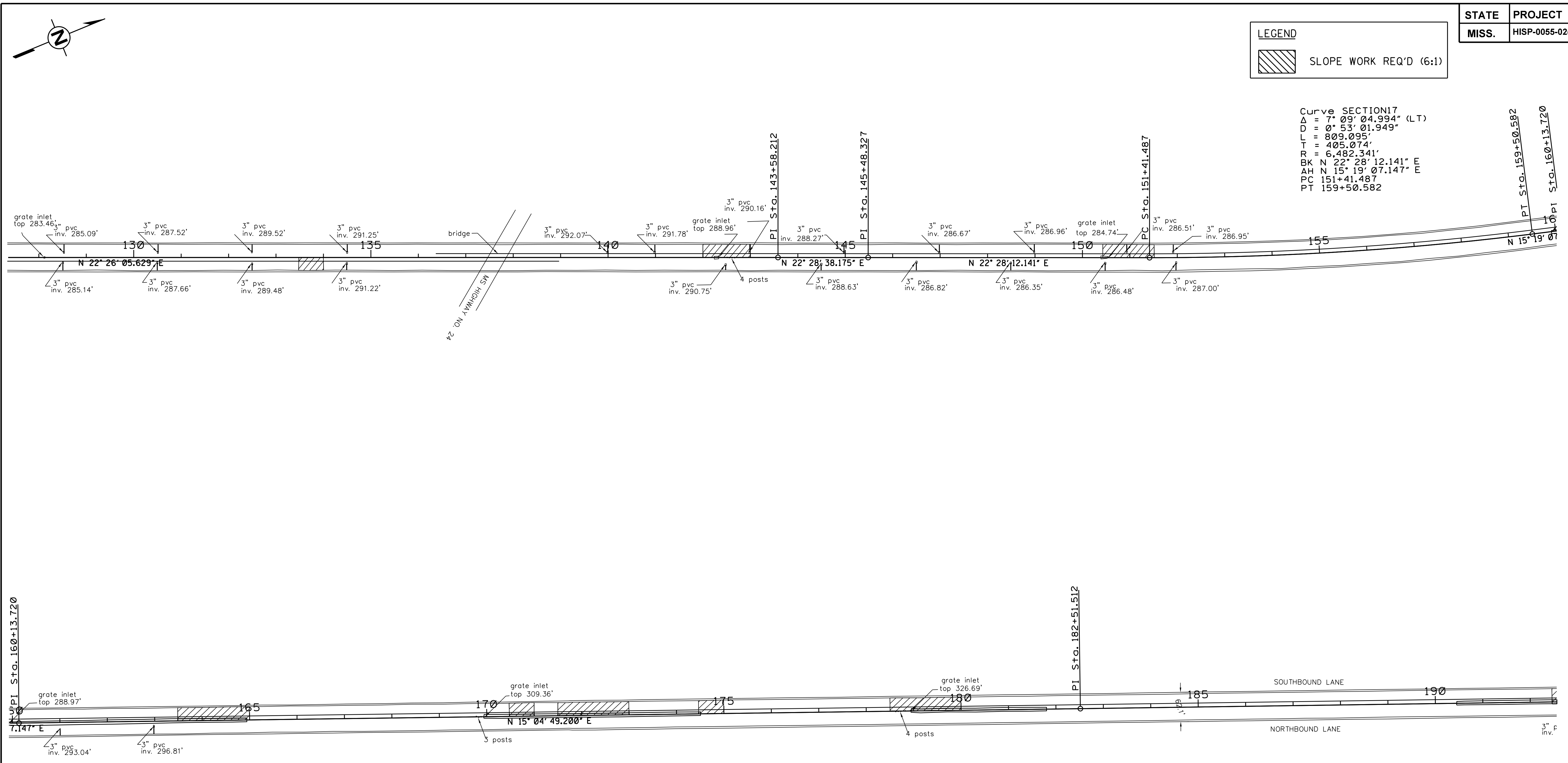

7/29/2019 4:37 PM ECP11.dgn

TEMPORARY EROSION CONTROL ITEMS	UNITS	SYMBOL	TOTALS
SILT FENCE	L.F.	—SF—	
SUPER SILT FENCE	L.F.	—SSF—	
WATTLES, 12"	L.F.		
WATTLES, 20"	L.F.		
TRIANGULAR SILT DIKE	L.F.		
SANDBAGS	L.F.		
RIPRAP	TON		
EROSION CHECKS	BALE		
TYPE D SILT BASINS	EACH		

MISSISSIPPI DEPARTMENT OF TRANSPORTATION

**HOLMES COUNTY SECTION 1
PLAN VIEW**

PROJ. NO.: HSP-0055-02(250)
 COUNTY: HOLMES

FILENAME: ecp11.dgn
 DESIGN TEAM: GUEST CHECKED: MM DATE: 7/8/19

WORKING NUMBER
ECP11
 SHEET NUMBER
61

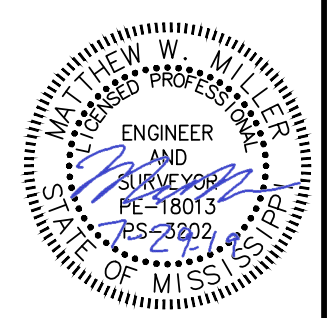

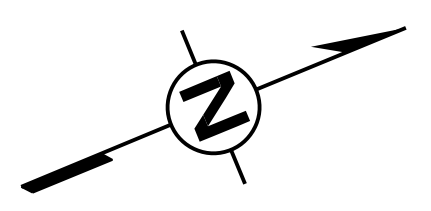

LEGEND

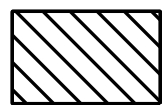
 SLOPE WORK REQ'D (6:1)

Curve SECTION18
 $\Delta = 1^\circ 13' 37.542''$ (LT)
 $D = 0^\circ 35' 22.031''$
 $L = 208.175'$
 $T = 104.092'$
 $R = 9,720.161'$
 $BK N 15^\circ 37' 47.381'' E$
 $AH N 14^\circ 24' 09.839'' E$
 $PC 210+36.565$
 $PT 212+44.740$

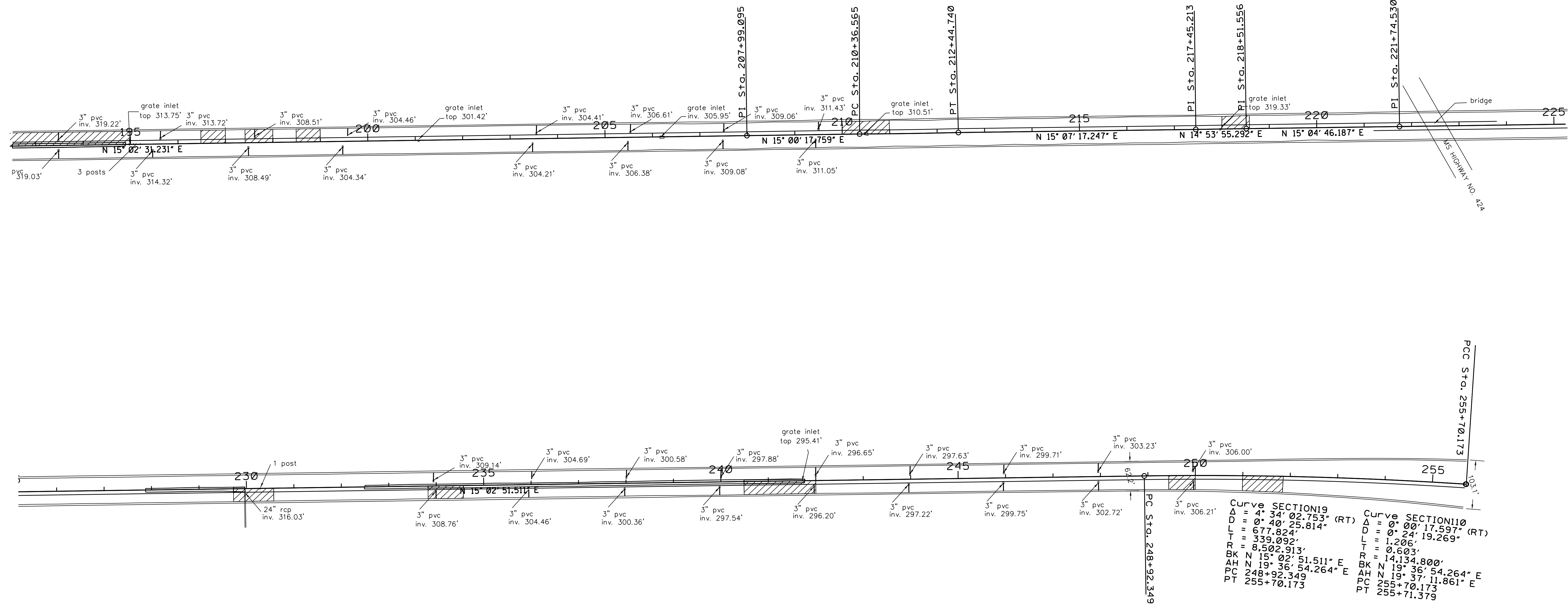

Curve SECTION19
 $\Delta = 4^\circ 34' 02.753''$ (RT)
 $D = 0^\circ 40' 25.814''$
 $L = 677.824'$
 $T = 339.092'$
 $R = 8,502.913'$
 $BK N 15^\circ 02' 51.511'' E$
 $AH N 19^\circ 36' 54.264'' E$
 $PC 248+92.349$
 $PT 255+70.173$

Curve SECTION110
 $\Delta = 0^\circ 00' 17.597''$ (RT)
 $D = 0^\circ 24' 19.269''$
 $L = 1.206'$
 $T = 0.603'$
 $R = 14,134.800'$
 $BK N 19^\circ 36' 54.264'' E$
 $AH N 19^\circ 37' 11.861'' E$
 $PC 255+70.173$
 $PT 255+71.379$

7/29/2019 4:37 PM ECP12.dgn PLAN DIVISION MISSISSIPPI DEPARTMENT OF TRANSPORTATION

TEMPORARY EROSION CONTROL ITEMS	UNITS	SYMBOL	TOTALS
SILT FENCE	L.F.	—SF—	
SUPER SILT FENCE	L.F.	—SSF—	
WATTLES, 12"	L.F.		
WATTLES, 20"	L.F.		
TRIANGULAR SILT DIKE	L.F.		
SANDBAGS	L.F.		
RIPRAP	TON		
EROSION CHECKS	BALE		
TYPE D SILT BASINS	EACH		

MISSISSIPPI DEPARTMENT OF TRANSPORTATION

**HOLMES COUNTY SECTION 1
PLAN VIEW**

PROJ. NO.: HSP-0055-02(250)
COUNTY: HOLMES

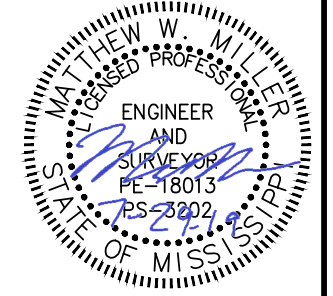
ENGINEER AND SURVEYOR

FILENAME: ecp12.dgn
 DESIGN TEAM: GUEST CHECKED: MM DATE: 7/8/19

WORKING NUMBER
ECP12
SHEET NUMBER
62

LEGEND

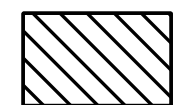
 SLOPE WORK REQ'D (6:1)

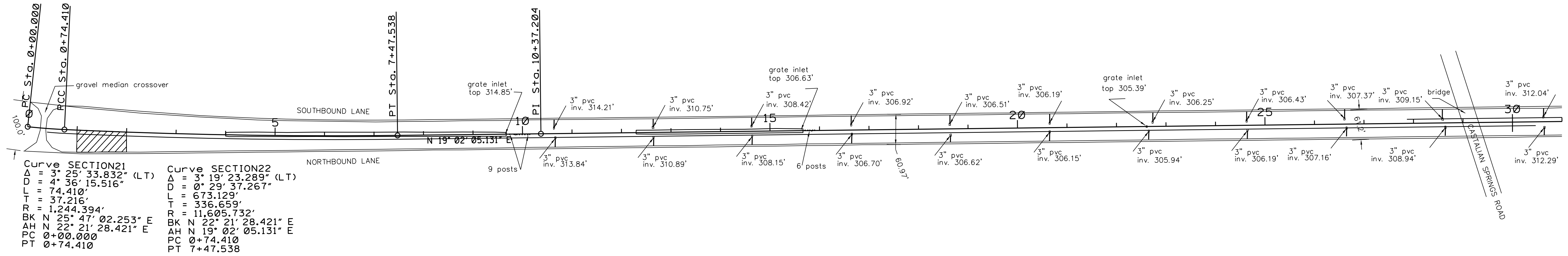
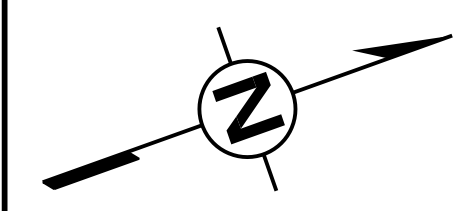

Curve SECTION 21
 $\Delta = 3^\circ 25' 33.832''$ (LT)
 $D = 4^\circ 36' 15.516''$
 $L = 74.410'$
 $T = 37.216'$
 $R = 1,244.394'$
 $BK N 25^\circ 47' 02.253'' E$
 $AH N 22^\circ 21' 28.421'' E$
 $PC 0+00.000$
 $PT 0+74.410$

Curve SECTION 22
 $\Delta = 3^\circ 19' 23.289''$ (LT)
 $D = 0^\circ 29' 37.267''$
 $L = 673.129'$
 $T = 336.659'$
 $R = 11,605.732'$
 $BK N 22^\circ 21' 28.421'' E$
 $AH N 19^\circ 02' 05.131'' E$
 $PC 0+74.410$
 $PT 7+47.538$

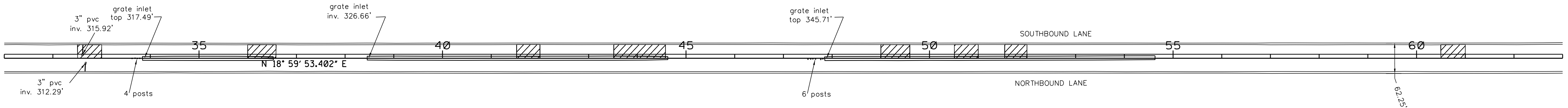

TEMPORARY EROSION CONTROL ITEMS	UNITS	SYMBOL	TOTALS
SILT FENCE	L.F.	-SF-	
SUPER SILT FENCE	L.F.	-SSF-	
WATTLES, 12"	L.F.		
WATTLES, 20"	L.F.		
TRIANGULAR SILT DIKE	L.F.		
SANDBAGS	L.F.		
RIPRAP	TON		
EROSION CHECKS	BALE		
TYPE D SILT BASINS	EACH		

MISSISSIPPI DEPARTMENT OF TRANSPORTATION

**HOLMES COUNTY SECTION 2
PLAN VIEW**

PROJ. NO.: HSP-0055-02(250)
 COUNTY: HOLMES

WORKING NUMBER
ECP13
 SHEET NUMBER
63

ENGINEER AND SURVEYOR
 W. W. WILSON
 PE #8013
 PS #2802
 STATE OF MISSISSIPPI

FILENAME: ecp13.dgn
 DESIGN TEAM: GUEST
 CHECKED: MM
 DATE: 7/8/19

7/29/2019 4:37 PM ECP13.DGN

STATE	PROJECT NO.
MISS.	HSIP-0055-02(250)

LEGEND

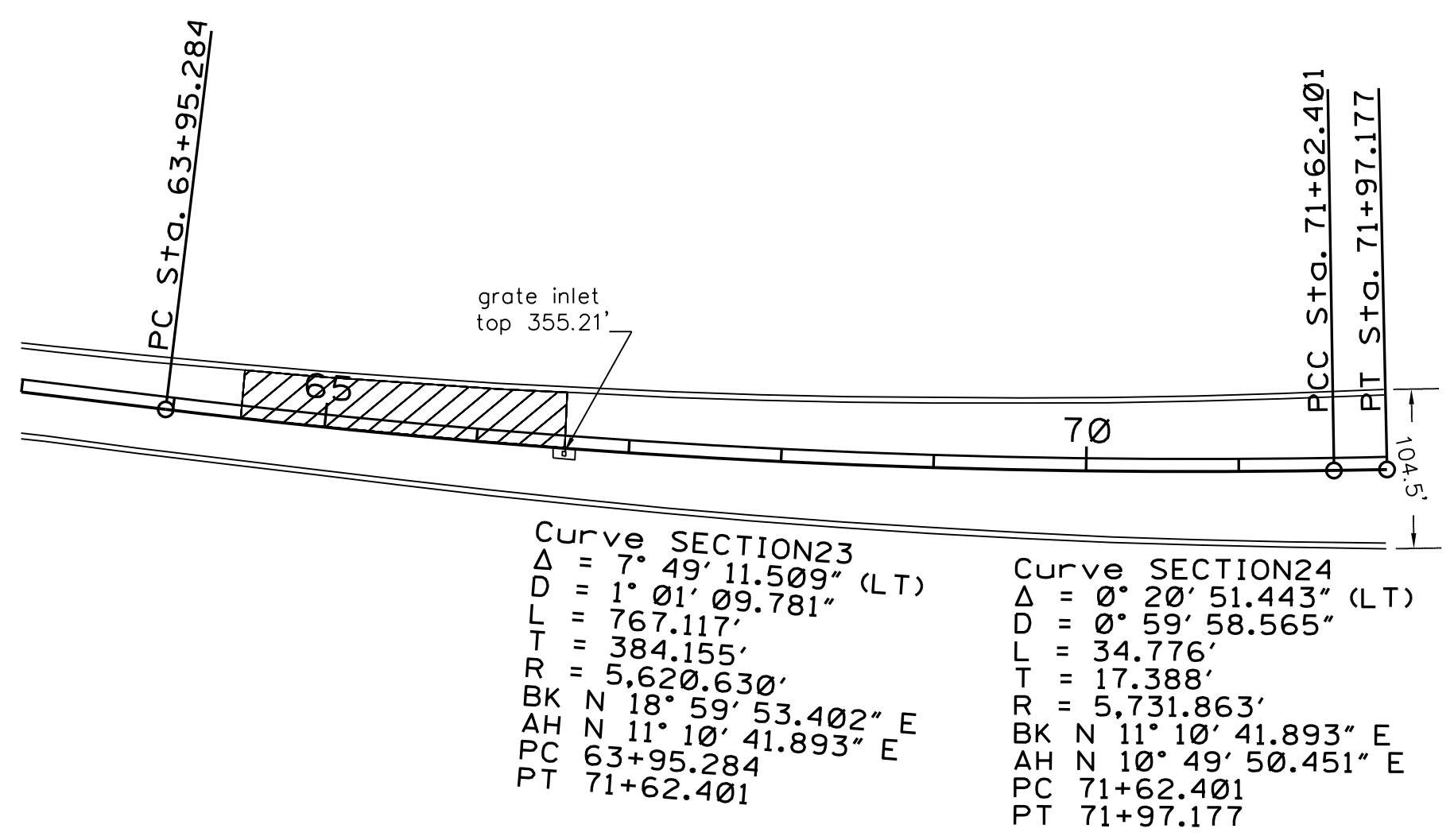
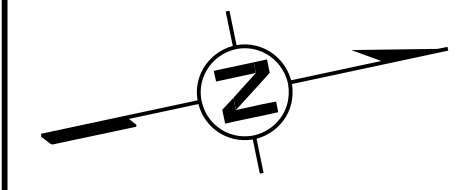

Curve SECTION23
 $\Delta = 7^\circ 49' 11.509''$ (LT)
 $D = 1^\circ 01' 09.781''$
 $L = 767.117'$
 $T = 384.155'$
 $R = 5,620.630'$
 BK N $18^\circ 59' 53.402''$ E
 AH N $11^\circ 10' 41.893''$ E
 PC 63+95.284
 PT 71+62.401

Curve SECTION24
 $\Delta = 0^\circ 20' 51.443''$ (LT)
 $D = 0^\circ 59' 58.565''$
 $L = 34.776'$
 $T = 17.388'$
 $R = 5,731.863'$
 BK N $11^\circ 10' 41.893''$ E
 AH N $10^\circ 49' 50.451''$ E
 PC 71+62.401
 PT 71+97.177

7/29/2019 4:37 PM ECP14.dgn

TEMPORARY EROSION CONTROL ITEMS	UNITS	SYMBOL	TOTALS
SILT FENCE	L.F.	—SF—	
SUPER SILT FENCE	L.F.	—SSF—	
WATTLES, 12"	L.F.	▨	
WATTLES, 20"	L.F.	▨	
TRIANGULAR SILT DIKE	L.F.	▨	
SANDBAGS	L.F.	▨	
RIPRAP	TON	▨	
EROSION CHECKS	BALE	▨	
TYPE D SILT BASINS	EACH	▨	

MISSISSIPPI DEPARTMENT OF TRANSPORTATION	
HOLMES COUNTY SECTION 2 PLAN VIEW	
PROJ. NO.: HSIP-0055-02(250) COUNTY: HOLMES	
DATE	WORKING NUMBER
DESIGN TEAM	ECP14
GUEST	SHEET NUMBER
CHECKED	64
MM	
DATE	
7/8/19	

STATE	PROJECT NO.
MISS.	HSIP-0055-02(250)

LEGEND

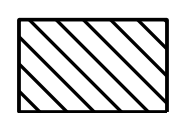
 SLOPE WORK REQ'D (6:1)

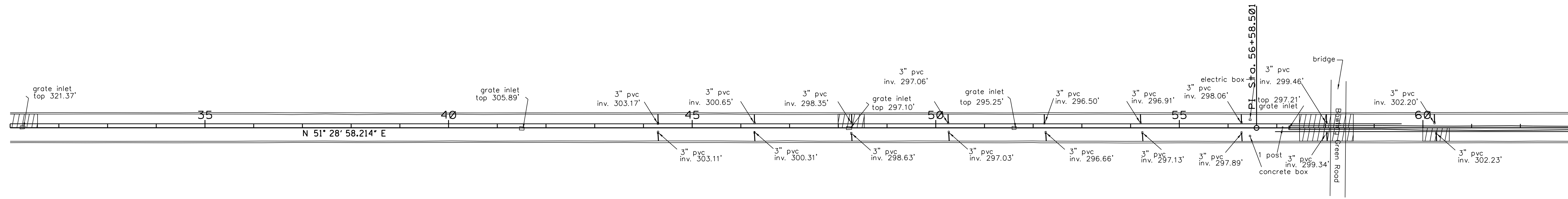
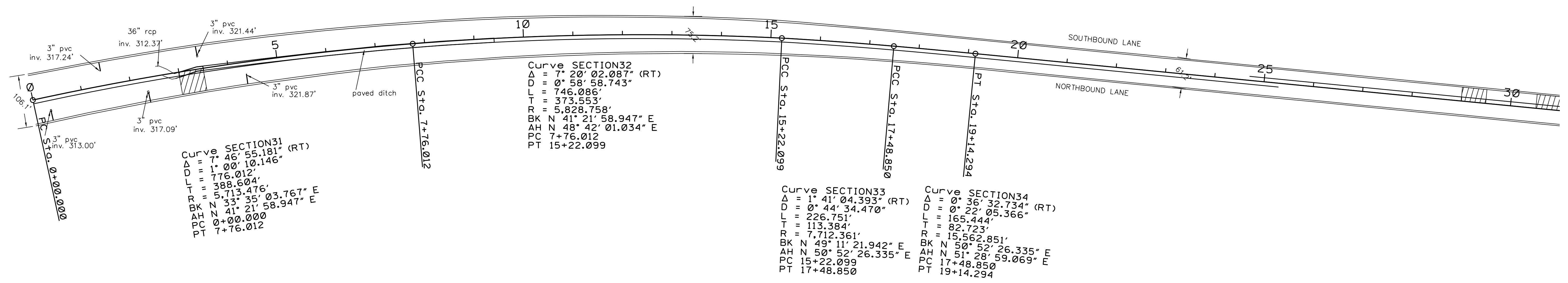
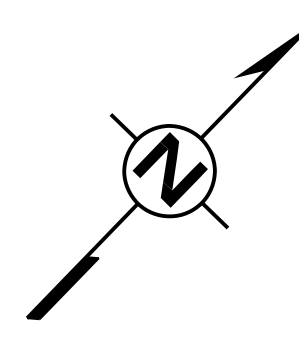

TEMPORARY EROSION CONTROL ITEMS	UNITS	SYMBOL	TOTALS
SILT FENCE	L.F.	-SF-	
SUPER SILT FENCE	L.F.	-SSF-	
WATTLES, 12"	L.F.		
WATTLES, 20"	L.F.		
TRIANGULAR SILT DIKE	L.F.		
SANDBAGS	L.F.		
RIPRAP	TON		
EROSION CHECKS	BALE		
TYPE D SILT BASINS	EACH		

MISSISSIPPI DEPARTMENT OF TRANSPORTATION

**HOLMES COUNTY SECTION 3
PLAN VIEW**

PROJ. NO.: HSIP-0055-02(250)
 COUNTY: HOLMES

WORKING NUMBER
ECP15
 SHEET NUMBER
65

FILENAME: ecp15.dgn

DESIGN TEAM: GUEST CHECKED: MM DATE: 7/8/19

7/29/2019 4:37 PM ECP15.DGN



STATE	PROJECT NO.
MISS.	HSIP-0055-02(250)

LEGEND

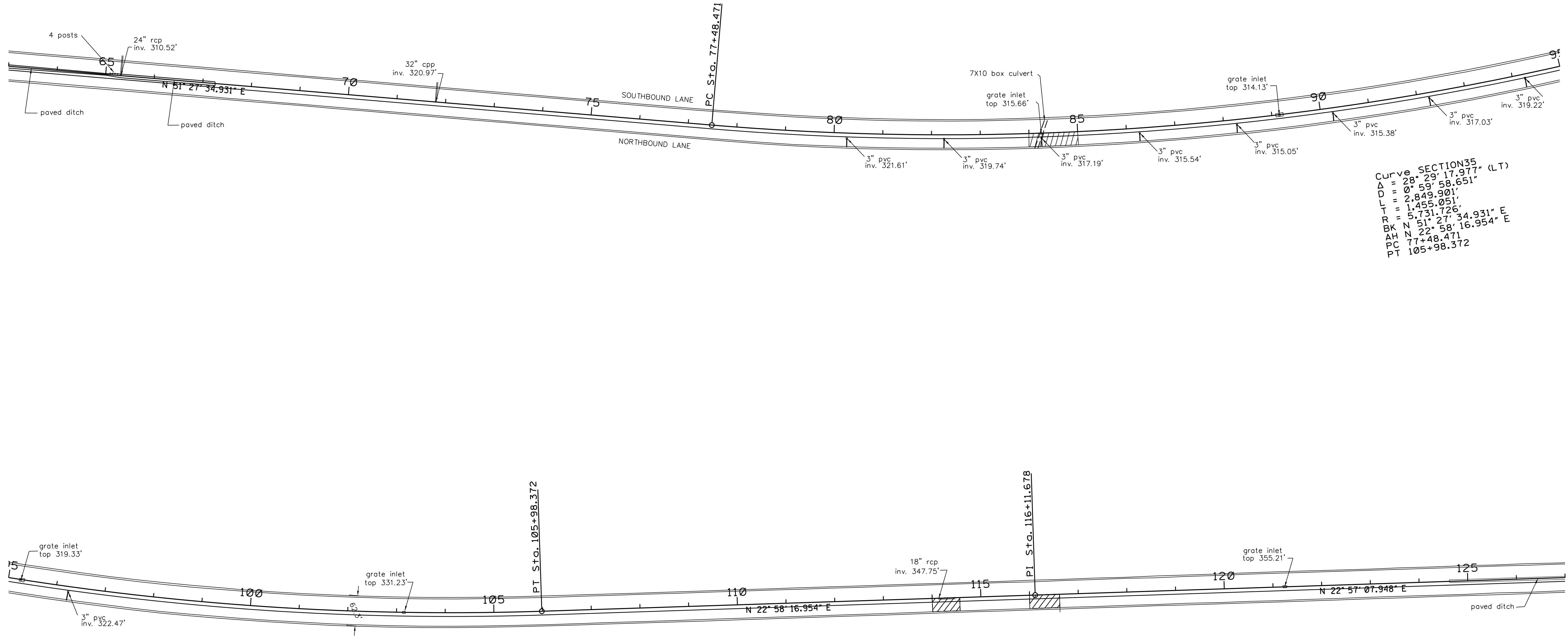
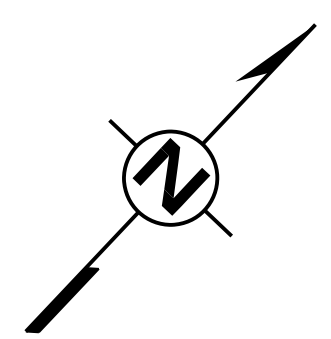
 SLOPE WORK REQ'D (6:1)

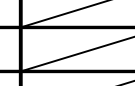
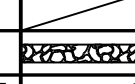
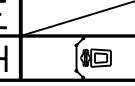

7/29/2019 4:37 PM ECP16.dgn PLAN DIVISION MISSISSIPPI DEPARTMENT OF TRANSPORTATION

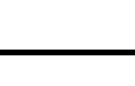
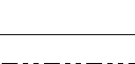
TEMPORARY EROSION CONTROL ITEMS	UNITS	SYMBOL	TOTALS
SILT FENCE	L.F.	—SF—	
SUPER SILT FENCE	L.F.	—SSF—	
WATTLES, 12"	L.F.		
WATTLES, 20"	L.F.		
TRIANGULAR SILT DIKE	L.F.		
SANDBAGS	L.F.		
RIPRAP	TON		
EROSION CHECKS	BALE		
TYPE D SILT BASINS	EACH		

MISSISSIPPI DEPARTMENT OF TRANSPORTATION

**HOLMES COUNTY SECTION 3
PLAN VIEW**

PROJ. NO.: HSIP-0055-02(250)
 COUNTY: HOLMES

WORKING NUMBER
ECP16
 SHEET NUMBER
66

FILENAME: ecp16.dgn
 DESIGN TEAM: GUEST CHECKED: MM DATE: 7/8/19

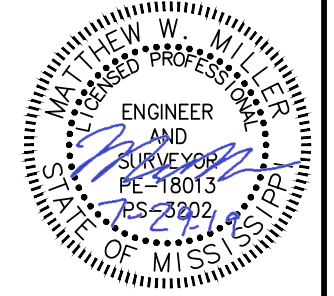

STATE	PROJECT NO.
MISS.	HSIP-0055-02(250)

LEGEND

 SLOPE WORK REQ'D (6:1)

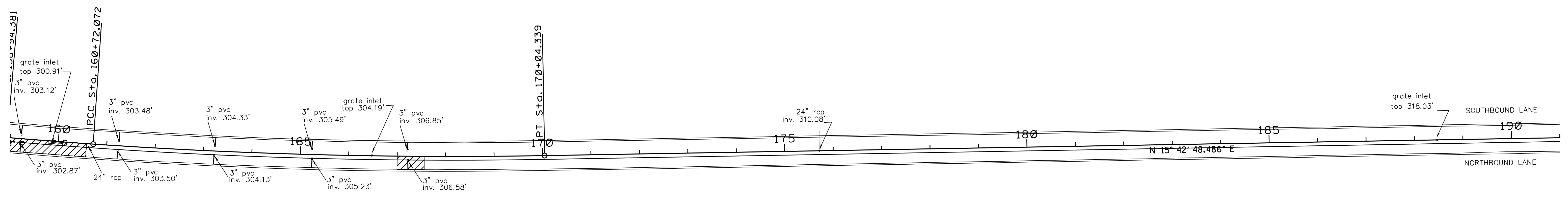
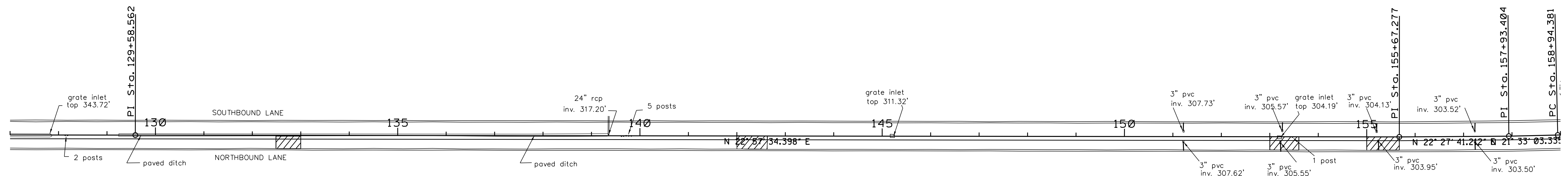
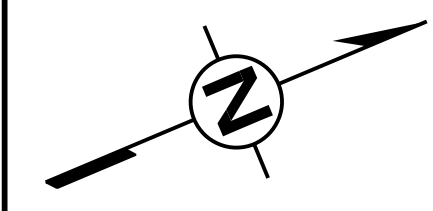

Curve SECTION36
 $\Delta = 0^\circ 54' 48.153''$ (LT)
 $D = 0^\circ 30' 50.493''$
 $L = 177.691'$
 $R = 88.847'$
 $T = 11,146.478'$
 BK N $21^\circ 33' 03.335''$ E
 AH N $20^\circ 38' 15.182''$ E
 PC 158+94.381
 PT 160+72.072

Curve SECTION37
 $\Delta = 4^\circ 55' 26.696''$ (LT)
 $D = 0^\circ 31' 41.461''$
 $L = 932.267'$
 $R = 466.421'$
 $T = 10,847.700'$
 BK N $20^\circ 38' 15.182''$ E
 AH N $15^\circ 42' 48.486''$ E
 PC 160+72.072
 PT 170+04.339

TEMPORARY EROSION CONTROL ITEMS	UNITS	SYMBOL	TOTALS
SILT FENCE	L.F.	--SF--	
SUPER SILT FENCE	L.F.	--SSF--	
WATTLES, 12"	L.F.		
WATTLES, 20"	L.F.		
TRIANGULAR SILT DIKE	L.F.		
SANDBAGS	L.F.		
RIPRAP	TON		
EROSION CHECKS	BALE		
TYPE D SILT BASINS	EACH		

MISSISSIPPI DEPARTMENT OF TRANSPORTATION

**HOLMES COUNTY SECTION 3
PLAN VIEW**

PROJ. NO.: HSIP-0055-02(250)
 COUNTY: HOLMES

ENGINEER AND SURVEYOR
 W. W. WILSON
 PE 18013
 MS 2802
 STATE OF MISSISSIPPI

WORKING NUMBER
ECP17
 SHEET NUMBER
67

FILENAME: ecp17.dgn
 DESIGN TEAM: GUEST CHECKED: MM DATE: 7/8/19

7/29/2019 4:37 PM ECP17.DGN

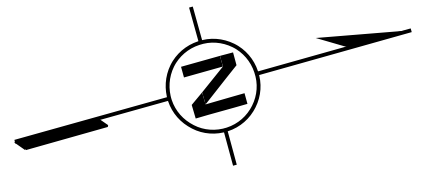

STATE	PROJECT NO.
MISS.	HSIP-0055-02(250)

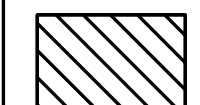

LEGEND

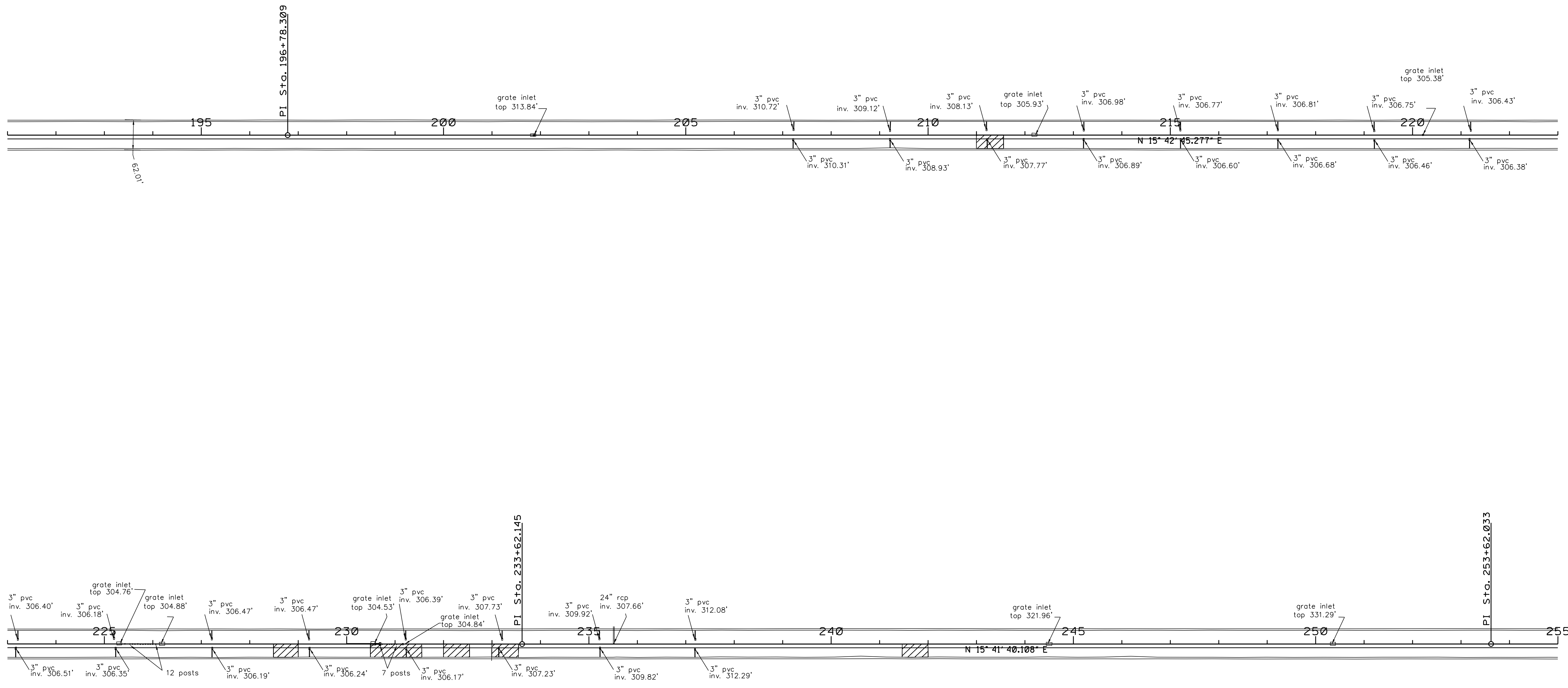
 SLOPE WORK REQ'D (6:1)

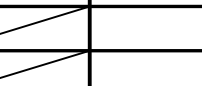
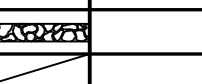
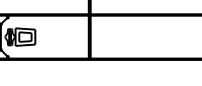

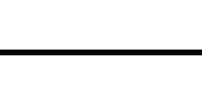
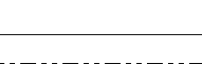
TEMPORARY EROSION CONTROL ITEMS	UNITS	SYMBOL	TOTALS
SILT FENCE	L.F.	—SF—	
SUPER SILT FENCE	L.F.	—SSF—	
WATTLES, 12"	L.F.		
WATTLES, 20"	L.F.		
TRIANGULAR SILT DIKE	L.F.		
SANDBAGS	L.F.		
RIPRAP	TON		
EROSION CHECKS	BALE		
TYPE D SILT BASINS	EACH		

MISSISSIPPI DEPARTMENT OF TRANSPORTATION

**HOLMES COUNTY SECTION 3
PLAN VIEW**

PROJ. NO.: HSIP-0055-02(250)
COUNTY: HOLMES

FILENAME: ecp18.dgn

DESIGN TEAM: GUEST CHECKED: MM DATE: 7/8/19

WORKING NUMBER
ECP18

SHEET NUMBER
68

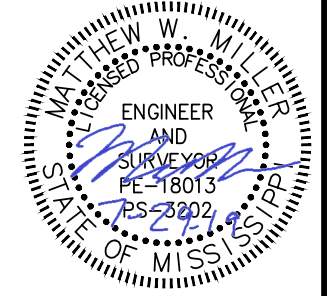





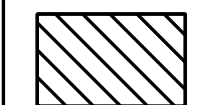

7/29/2019 4:37 PM ECP18.dgn MISSISSIPPI DEPARTMENT OF TRANSPORTATION

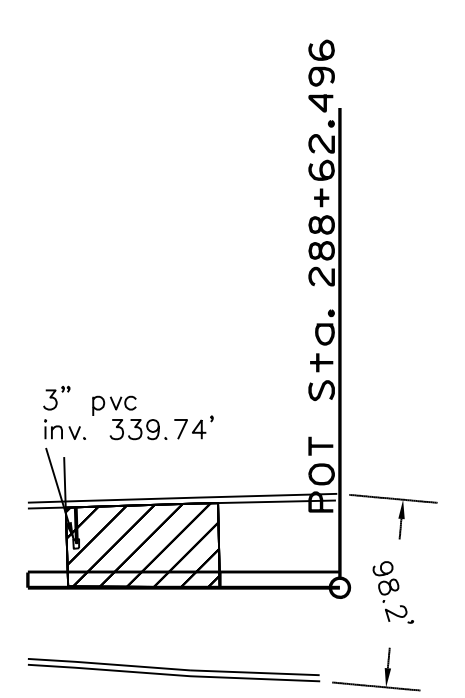
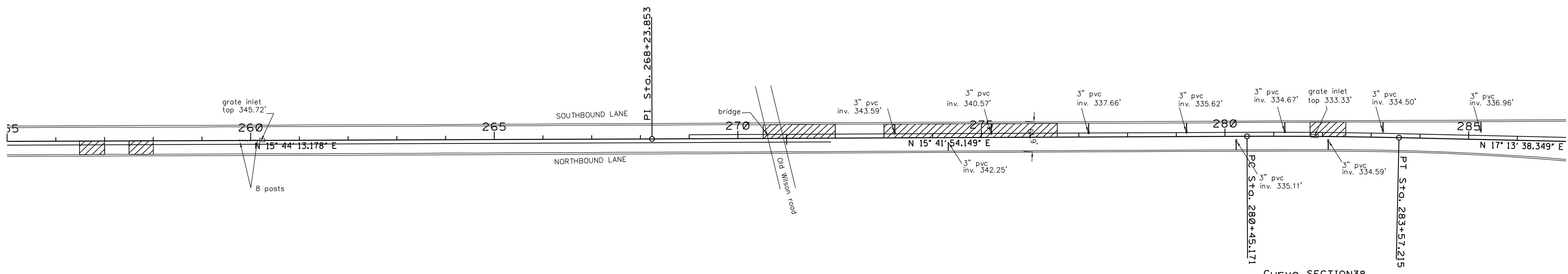
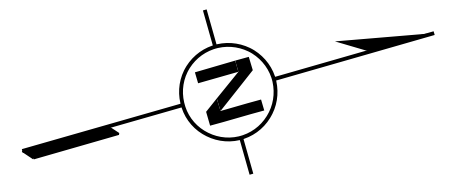
STATE	PROJECT NO.
MISS.	HSIP-0055-02(250)

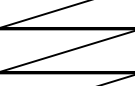
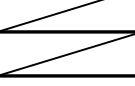
LEGEND

 SLOPE WORK REQ'D (6:1)



TEMPORARY EROSION CONTROL ITEMS	UNITS	SYMBOL	TOTALS
SILT FENCE	L.F.	--SF--	
SUPER SILT FENCE	L.F.	--SSF--	
WATTLES, 12"	L.F.		
WATTLES, 20"	L.F.		
TRIANGULAR SILT DIKE	L.F.		
SANDBAGS	L.F.		
RIPRAP	TON		
EROSION CHECKS	BALE		
TYPE D SILT BASINS	EACH		

MISSISSIPPI DEPARTMENT OF TRANSPORTATION

**HOLMES COUNTY SECTION 3
PLAN VIEW**

PROJ. NO.: HSIP-0055-02(250)
 COUNTY: HOLMES

ENGINEER AND SURVEYOR
 W. W. WILSON
 PE 18013
 PS 28024
 STATE OF MISSISSIPPI

WORKING NUMBER
ECP19

SHEET NUMBER
69

FILENAME: ecp19.dgn

DESIGN TEAM: GUEST CHECKED: MM DATE: 7/8/19

7/29/2019 4:37 PM ECP19.dgn

LEGEND

SLOPE WORK REQ'D (6:1)

IMPAIRED WATER BODY
 JORDAN CREEK IS IMPAIRED
 DUE TO BIOLOGICAL IMPAIRMENT

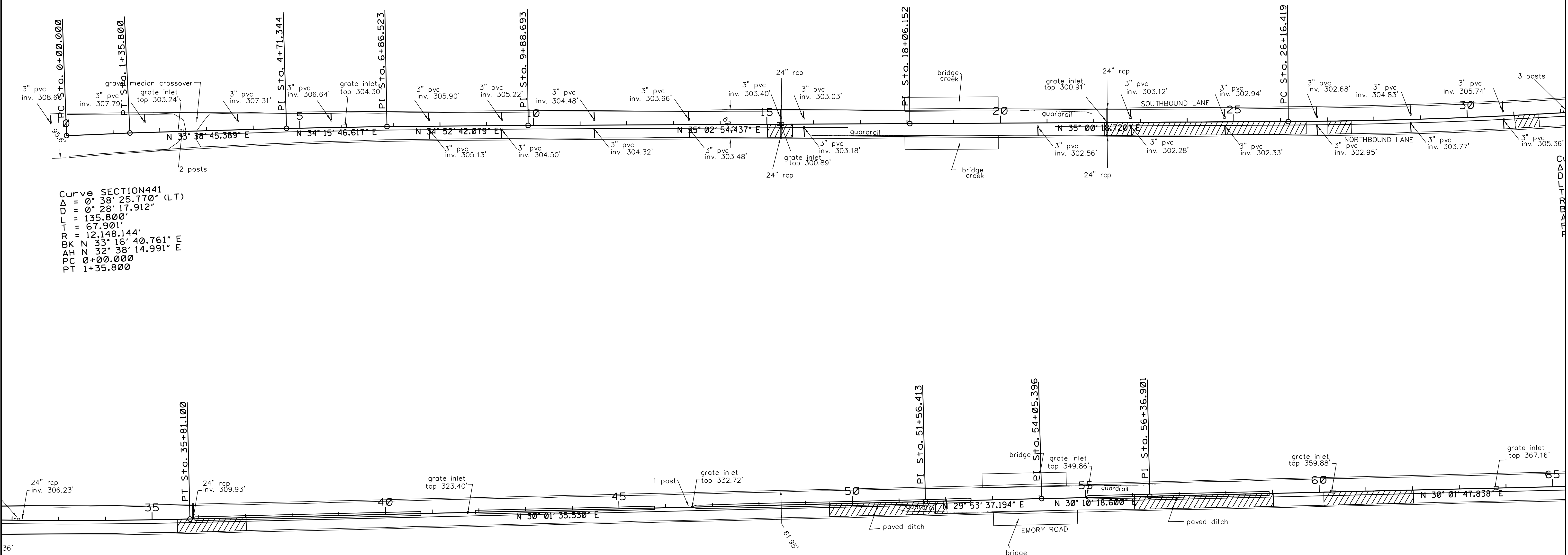

Curve SECTION441
 $\Delta = 0^\circ 38' 25.770''$ (LT)
 $D = 0^\circ 28' 17.912''$
 $L = 135.800'$
 $T = 67.901'$
 $R = 12,148.144'$
 BK N $33^\circ 16' 40.761''$ E
 AH N $32^\circ 38' 14.991''$ E
 PC 0+00.000
 PT 1+35.800

Curve SECTION442
 $\Delta = 4^\circ 58' 43.190''$ (LT)
 $D = 0^\circ 30' 57.940''$
 $L = 964.681'$
 $T = 482.644'$
 $R = 11,101.804'$
 BK N $35^\circ 00' 18.720''$ E
 AH N $30^\circ 01' 35.530''$ E
 PC 26+16.419
 PT 35+81.100

TEMPORARY EROSION CONTROL ITEMS	UNITS	SYMBOL	TOTALS
SILT FENCE	L.F.	—SF—	
SUPER SILT FENCE	L.F.	—SSF—	
WATTLES, 12"	L.F.		
WATTLES, 20"	L.F.		
TRIANGULAR SILT DIKE	L.F.		
SANDBAGS	L.F.		
RIPRAP	TON		
EROSION CHECKS	BALE		
TYPE D SILT BASINS	EACH		

MISSISSIPPI DEPARTMENT OF TRANSPORTATION

**HOLMES COUNTY SECTION 4
 PLAN VIEW**

PROJ. NO.: HSIP-0055-02(250)
 COUNTY: HOLMES

ENGINEER AND SURVEYOR
 W. W. WILSON
 PE-18013
 MS-2802

WORKING NUMBER
ECP20

SHEET NUMBER
70

FILENAME: **ecp20.dgn**

DESIGN TEAM: GUEST CHECKED: MM DATE: 7/8/19

B:\22\2019 1:32 PM ECP20.DGN
 ROADWAY PLAN DIVISION
 MISSISSIPPI DEPARTMENT OF TRANSPORTATION

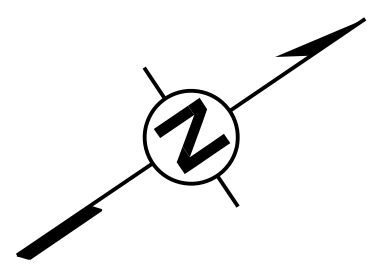

LEGEND

SLOPE WORK REQ'D (6:1)

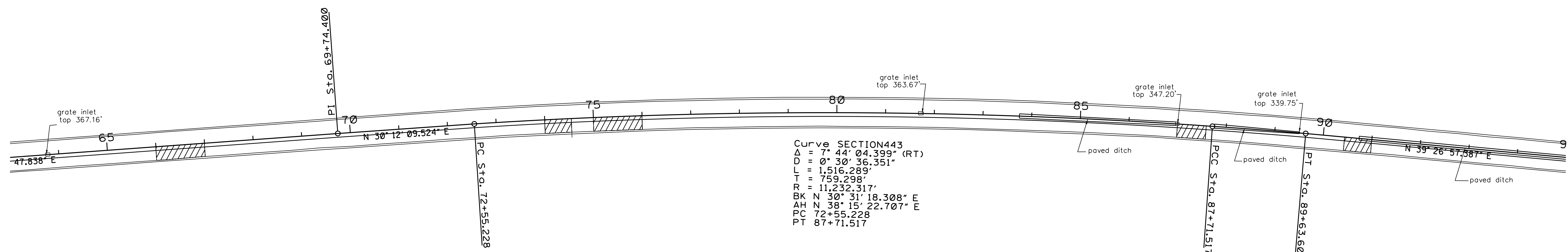

Curve SECTION444
 $\Delta = 1^{\circ} 03' 15.682''$ (RT)
 $D = 0^{\circ} 32' 56.014''$
 $L = 192.088'$
 $T = 96.047'$
 $R = 10,438.429'$
 $BK N 38^{\circ} 04' 31.070'' E$
 $AH N 39^{\circ} 07' 46.752'' E$
 $PC 87+71.517$
 $PT 89+63.605$

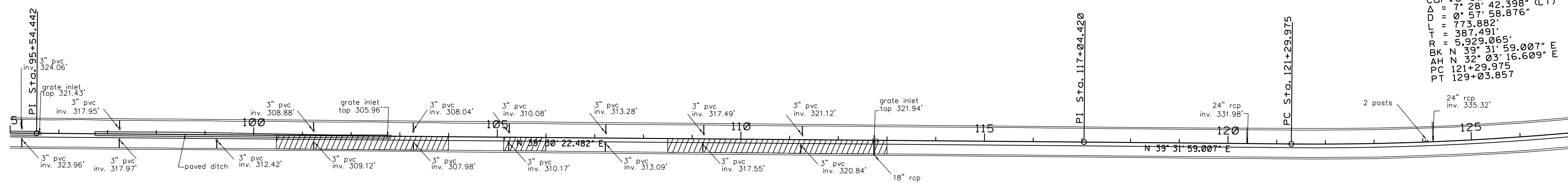

Curve SECTION445
 $\Delta = 7^{\circ} 28' 42.398''$ (LT)
 $D = 0^{\circ} 57' 58.876''$
 $L = 773.882'$
 $T = 387.491'$
 $R = 5,929.065'$
 $BK N 39^{\circ} 31' 59.007'' E$
 $AH N 32^{\circ} 03' 16.609'' E$
 $PC 121+29.975$
 $PT 129+03.857$

ROADWAY PLAN DIVISION MISSISSIPPI DEPARTMENT OF TRANSPORTATION

7/29/2019 4:37 PM ECP21.dgn

TEMPORARY EROSION CONTROL ITEMS	UNITS	SYMBOL	TOTALS
SILT FENCE	L.F.	-SF-	
SUPER SILT FENCE	L.F.	-SSF-	
WATTLES, 12"	L.F.		
WATTLES, 20"	L.F.		
TRIANGULAR SILT DIKE	L.F.		
SANDBAGS	L.F.		
RIPRAP	TON		
EROSION CHECKS	BALE		
TYPE D SILT BASINS	EACH		

MISSISSIPPI DEPARTMENT OF TRANSPORTATION

**HOLMES COUNTY SECTION 4
PLAN VIEW**

PROJ. NO.: HSIP-0055-02(250)
 COUNTY: HOLMES

ENGINEER AND SURVEYOR
 W. W. WILSON
 PE 18013
 MS 2902

WORKING NUMBER
ECP21
 SHEET NUMBER
71

FILENAME: **_ecp21.dgn**
 DESIGN TEAM: **GUEST** CHECKED: **MM** DATE: **7/8/19**

STATE	PROJECT NO.
MISS.	HSIP-0055-02(250)

LEGEND

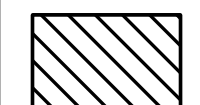
 SLOPE WORK REQ'D (6:1)

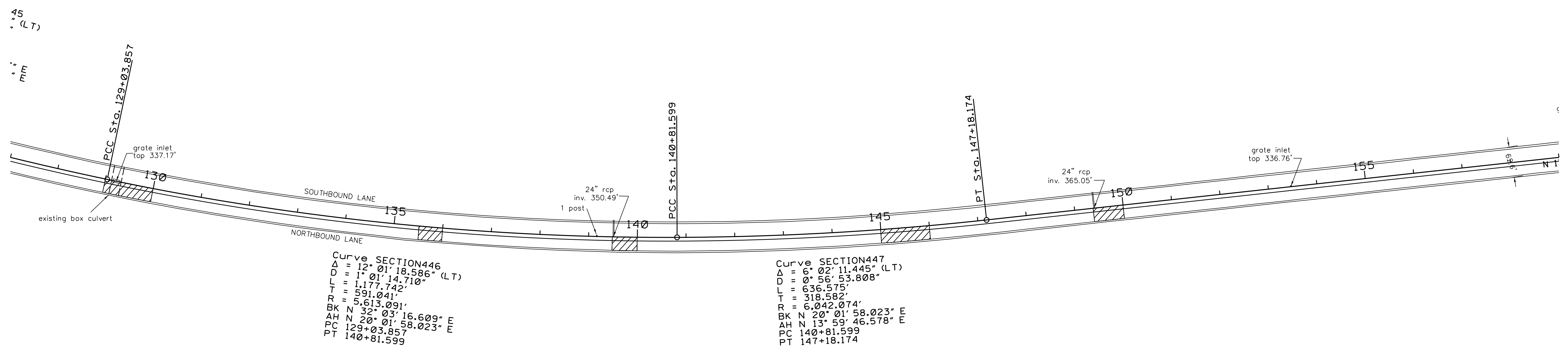
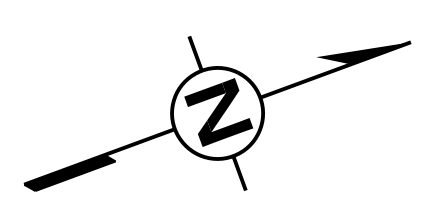

Curve SECTION 446
 $\Delta = 12^\circ 01' 18.586''$ (LT)
 $D = 1^\circ 01' 14.710''$
 $L = 1,177.742'$
 $T = 591.041'$
 $R = 5,613.091'$
 $BK N 32^\circ 03' 16.609'' E$
 $AH N 20^\circ 01' 58.023'' E$
 $PC 129+03.857$
 $PT 140+81.599$

Curve SECTION 447
 $\Delta = 6^\circ 02' 11.445''$ (LT)
 $D = 0^\circ 56' 53.808''$
 $L = 636.575'$
 $T = 318.582'$
 $R = 6,042.074'$
 $BK N 20^\circ 01' 58.023'' E$
 $AH N 13^\circ 59' 46.578'' E$
 $PC 140+81.599$
 $PT 147+18.174$

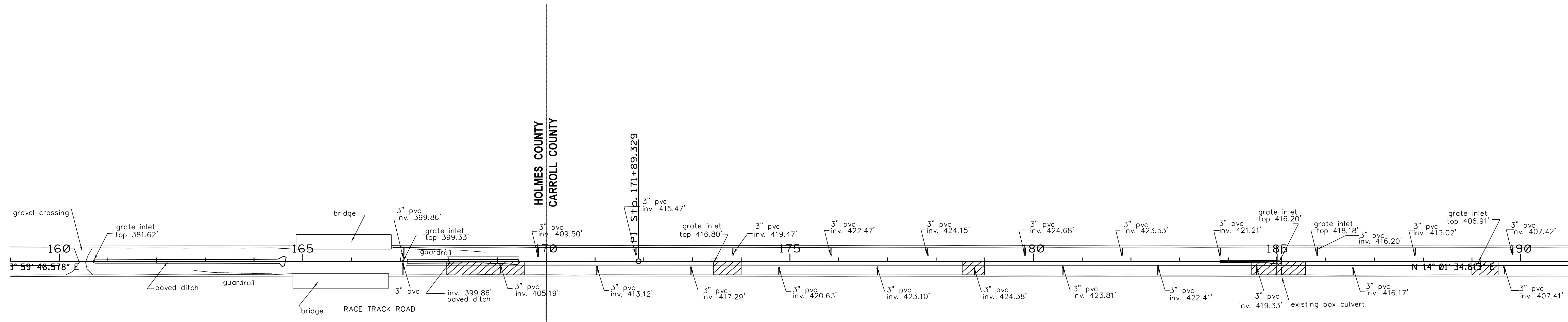

TEMPORARY EROSION CONTROL ITEMS	UNITS	SYMBOL	TOTALS
SILT FENCE	L.F.	-SF-	
SUPER SILT FENCE	L.F.	-SSF-	
WATTLES, 12"	L.F.		
WATTLES, 20"	L.F.		
TRIANGULAR SILT DIKE	L.F.		
SANDBAGS	L.F.		
RIPRAP	TON		
EROSION CHECKS	BALE		
TYPE D SILT BASINS	EACH		

MISSISSIPPI DEPARTMENT OF TRANSPORTATION

HOLMES/CARROLL COUNTY SECTION 4 PLAN VIEW

PROJ. NO.: HSIP-0055-02(250)
 COUNTY: HOLMES AND CARROLL

WORKING NUMBER: ECP22
 SHEET NUMBER: 72

FILENAME: ecp22.dgn
 DESIGN TEAM: GUEST
 CHECKED: MM
 DATE: 7/8/19

REVISION: BY: DATE

7/29/2019 4:37 PM ECP22.dgn

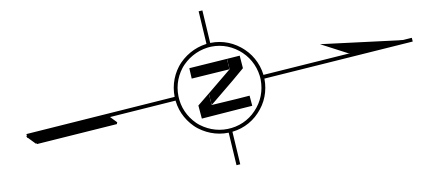

LEGEND

SLOPE WORK REQ'D (6:1)

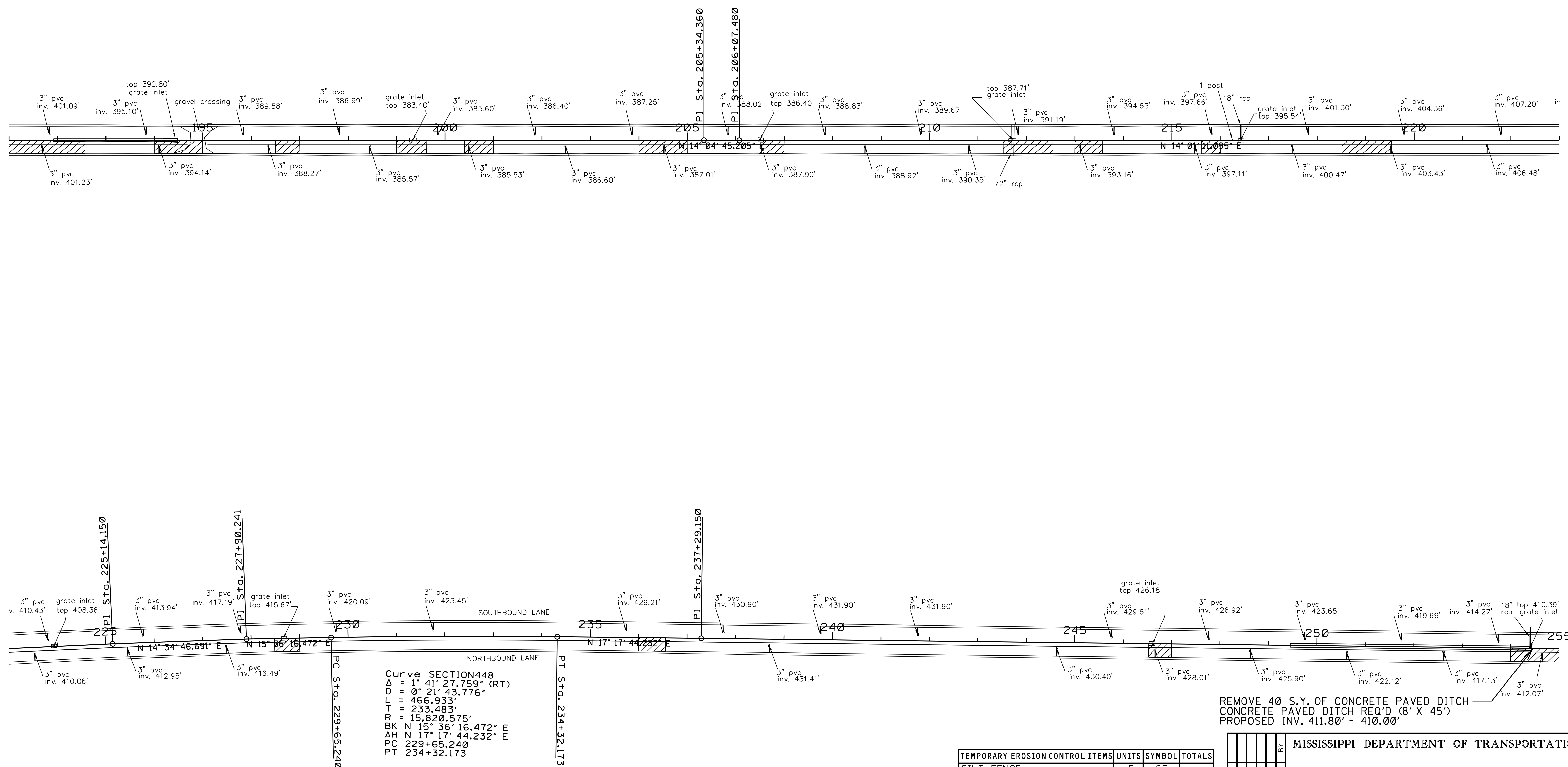

Curve SECTION 448
 $\Delta = 1^\circ 41' 27.759''$ (RT)
 $D = 0^\circ 21' 43.776''$
 $L = 466.933'$
 $T = 233.483'$
 $R = 15,820.575'$
 $BK N 15^\circ 36' 16.472'' E$
 $AH N 17^\circ 17' 44.232'' E$
 $PC 229+65.240$
 $PT 234+32.173$

REMOVE 40 S.Y. OF CONCRETE PAVED DITCH
 CONCRETE PAVED DITCH REQ'D (8' X 45')
 PROPOSED INV. 411.80' - 410.00'

TEMPORARY EROSION CONTROL ITEMS	UNITS	SYMBOL	TOTALS
SILT FENCE	L.F.	-SF-	
SUPER SILT FENCE	L.F.	-SSF-	
WATTLES, 12"	L.F.		
WATTLES, 20"	L.F.		
TRIANGULAR SILT DIKE	L.F.		
SANDBAGS	L.F.		
RIPRAP	TON		
EROSION CHECKS	BALE		
TYPE D SILT BASINS	EACH		

MISSISSIPPI DEPARTMENT OF TRANSPORTATION

**CARROLL COUNTY SECTION 4
PLAN VIEW**

PROJ. NO.: HSIP-0055-02(250)
 COUNTY: CARROLL

ENGINEER AND SURVEYOR
 W. W. WILSON
 PE 18013
 PS 28024
 STATE OF MISSISSIPPI

WORKING NUMBER
ECP23
 SHEET NUMBER
73

FILENAME: **ecp23.dgn**
 DESIGN TEAM: GUEST
 CHECKED: MM
 DATE: 7/8/19

7/29/2019 4:37 PM ECP23.dgn

LEGEND

 SLOPE WORK REQ'D (6:1)

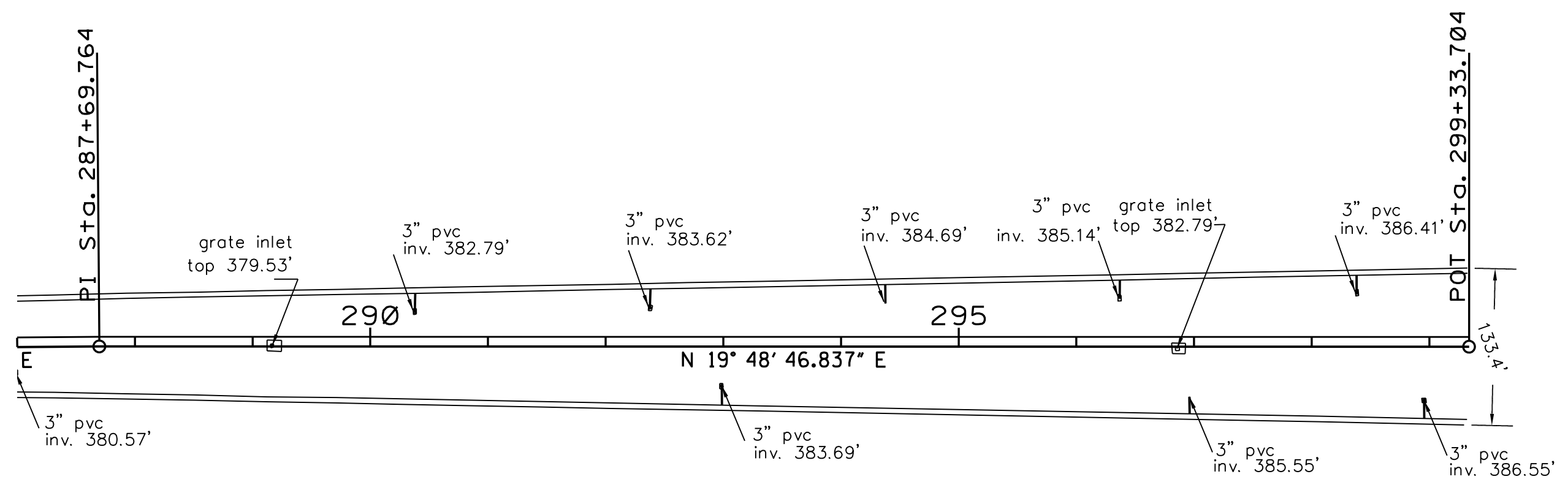
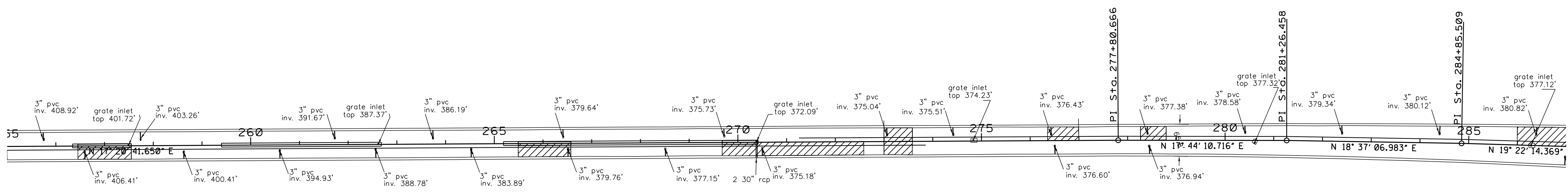
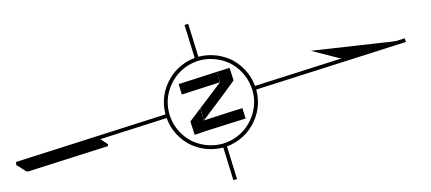

TEMPORARY EROSION CONTROL ITEMS	UNITS	SYMBOL	TOTALS
SILT FENCE	L.F.	-SF-	
SUPER SILT FENCE	L.F.	-SSF-	
WATTLES, 12"	L.F.		
WATTLES, 20"	L.F.		
TRIANGULAR SILT DIKE	L.F.		
SANDBAGS	L.F.		
RIPRAP	TON		
EROSION CHECKS	BALE		
TYPE D SILT BASINS	EACH		

MISSISSIPPI DEPARTMENT OF TRANSPORTATION	
CARROLL COUTNY SECTION 4 PLAN VIEW	
PROJ. NO.: HSIP-0055-02(250) COUNTY: CARROLL	
DATE	WORKING NUMBER
DESIGN TEAM	ECP24
CHECKED	SHEET NUMBER
DATE	74

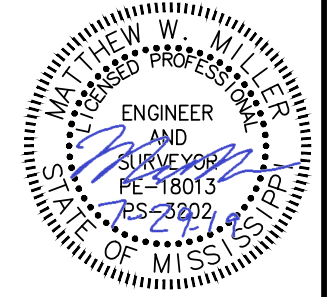

7/29/2019 4:37 PM ECP24.dgn

STATE	PROJECT NO.
MISS.	HSIP-0055-02(250)

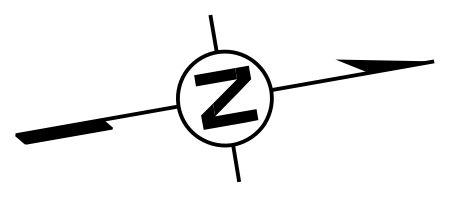

LEGEND

SLOPE WORK REQ'D (6:1)

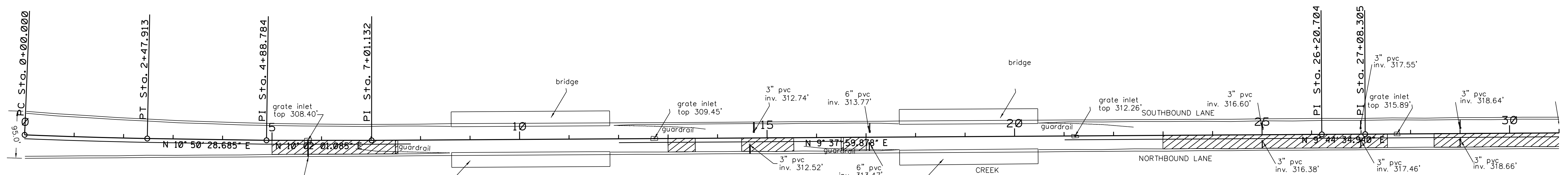

Curve SECTION551
 $\Delta = 1^\circ 08' 43.772''$ (LT)
 $D = 0^\circ 27' 43.395''$
 $L = 247.913'$
 $T = 123.961'$
 $R = 12,400.230'$
 BK N $12^\circ 16' 03.094''$ E
 AH N $11^\circ 07' 19.322''$ E
 PC 0+00.000
 PT 2+47.913

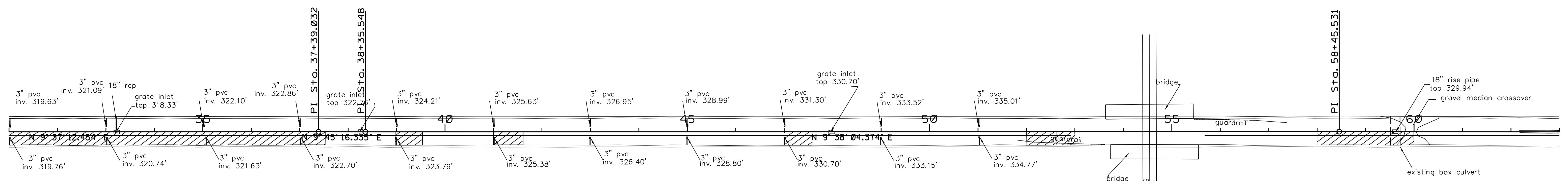

TEMPORARY EROSION CONTROL ITEMS	UNITS	SYMBOL	TOTALS
SILT FENCE	L.F.	—SF—	
SUPER SILT FENCE	L.F.	—SSF—	
WATTLES, 12"	L.F.	—W12—	
WATTLES, 20"	L.F.	—W20—	
TRIANGULAR SILT DIKE	L.F.	—TSD—	
SANDBAGS	L.F.	—SB—	
RIPRAP	TON	—RIP—	
EROSION CHECKS	BALE	—EC—	
TYPE D SILT BASINS	EACH	—TDB—	

MISSISSIPPI DEPARTMENT OF TRANSPORTATION

**CARROLL COUNTY SECTION 5
PLAN VIEW**

PROJ. NO.: HSIP-0055-02(250)
 COUNTY: CARROLL

ENGINEER AND SURVEYOR
 W. W. WILSON
 PE 18013
 PS 28024
 STATE OF MISSISSIPPI

FILENAME: ecp25.dgn

DESIGN TEAM: GUEST CHECKED: MM DATE: 7/8/19

WORKING NUMBER
ECP25
 SHEET NUMBER
75

7/29/2019 4:37 PM ECP25.DGN

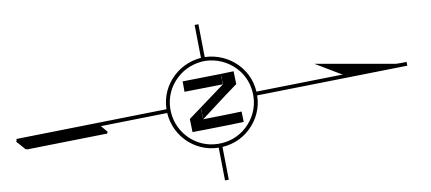

LEGEND

SLOPE WORK REQ'D (6:1)

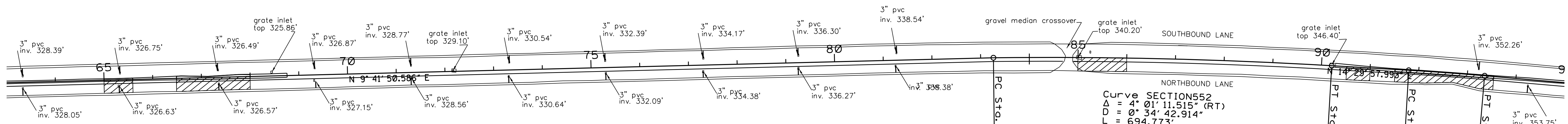

Curve SECTION 553
 $\Delta = 1^{\circ} 33' 30.603''$ (RT)
 $D = 0^{\circ} 59' 51.733''$
 $L = 156.209'$
 $T = 78.109'$
 $R = 5,742.766'$
 $BK N 14^{\circ} 29' 57.993'' E$
 $AH N 16^{\circ} 03' 28.597'' E$
 $PC 91+79.287$
 $PT 93+35.496$

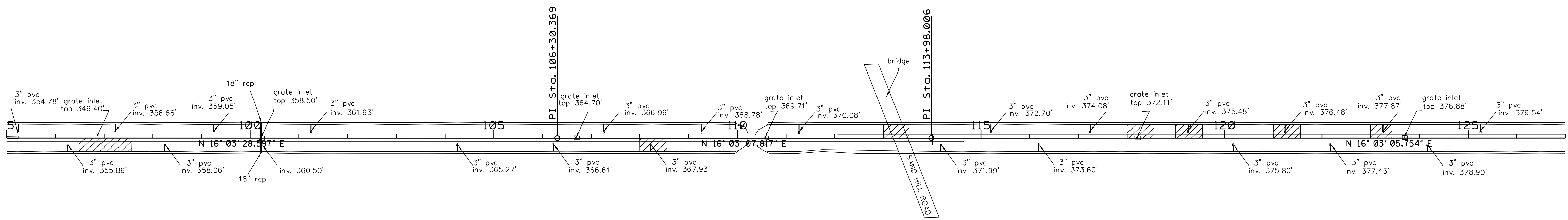

TEMPORARY EROSION CONTROL ITEMS	UNITS	SYMBOL	TOTALS
SILT FENCE	L.F.	—SF—	
SUPER SILT FENCE	L.F.	—SSF—	
WATTLES, 12"	L.F.		
WATTLES, 20"	L.F.		
TRIANGULAR SILT DIKE	L.F.		
SANDBAGS	L.F.		
RIPRAP	TON		
EROSION CHECKS	BALE		
TYPE D SILT BASINS	EACH		

MISSISSIPPI DEPARTMENT OF TRANSPORTATION

**CARROLL COUNTY SECTION 5
PLAN VIEW**

PROJ. NO.: HSIP-0055-02(250)
 COUNTY: CARROLL

ENGINEER AND SURVEYOR
 W. W. WILSON
 PE 18013
 MS 2802
 STATE OF MISSISSIPPI

WORKING NUMBER
ECP26
 SHEET NUMBER
76

FILENAME: ecp26.dgn
 DESIGN TEAM: GUEST CHECKED: MM DATE: 7/8/19

7/29/2019 4:37 PM ECP26.dgn

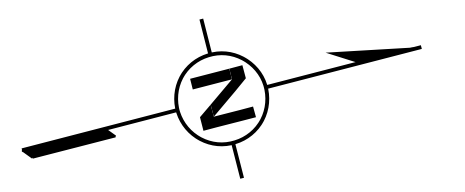

LEGEND

 SLOPE WORK REQ'D (6:1)

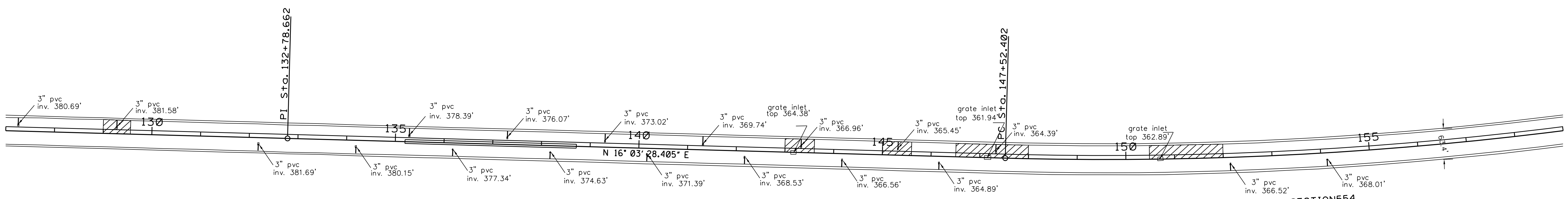

Curve SECTION554
 Δ = 9° 27' 28.537" (LT)
 D = 0° 45' 51.355"
 L = 1,237.519'
 T = 620.168'
 R = 7,496.844'
 BK N 16° 03' 28.405" E
 AH N 6° 35' 59.868" E
 PC 147+52.402
 PT 159+89.921

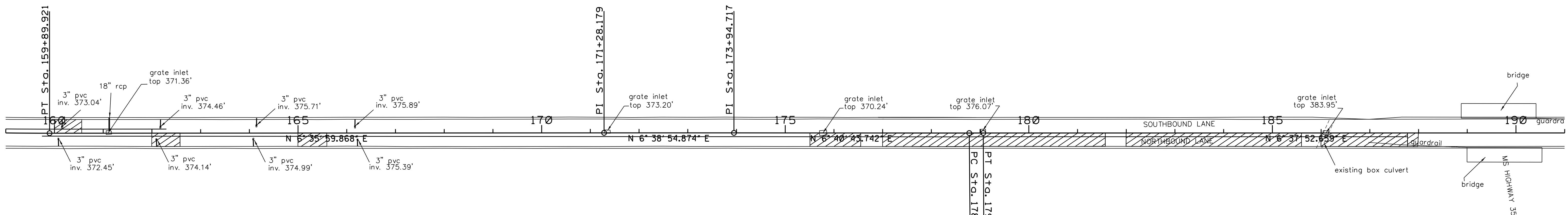

TEMPORARY EROSION CONTROL ITEMS	UNITS	SYMBOL	TOTALS
SILT FENCE	L.F.	-SF-	
SUPER SILT FENCE	L.F.	-SSF-	
WATTLES, 12"	L.F.		
WATTLES, 20"	L.F.		
TRIANGULAR SILT DIKE	L.F.		
SANDBAGS	L.F.		
RIPRAP	TON		
EROSION CHECKS	BALE		
TYPE D SILT BASINS	EACH		

Curve SECTION555
 Δ = 0° 11' 11.245" (RT)
 D = 0° 38' 53.114"
 L = 28.770'
 T = 14.385'
 R = 8,840.751'
 BK N 6° 08' 09.906" E
 AH N 6° 19' 21.151" E
 PC 178+77.742
 PT 179+06.512

MISSISSIPPI DEPARTMENT OF TRANSPORTATION	
CARROLL COUNTY SECTION 5 PLAN VIEW	
PROJ. NO.: HSIP-0055-02(250) COUNTY: CARROLL	
DATE	WORKING NUMBER
DESIGN TEAM	ECP27
GUEST	SHEET NUMBER
CHECKED	77
MM	
DATE	
7/8/19	

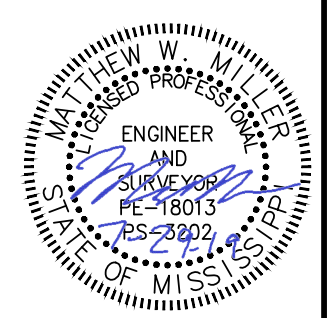

7/29/2019 4:37 PM ECP27.DGN

STATE	PROJECT NO.
MISS.	HSIP-0055-02(250)

LEGEND

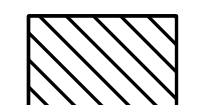
 SLOPE WORK REQ'D (6:1)

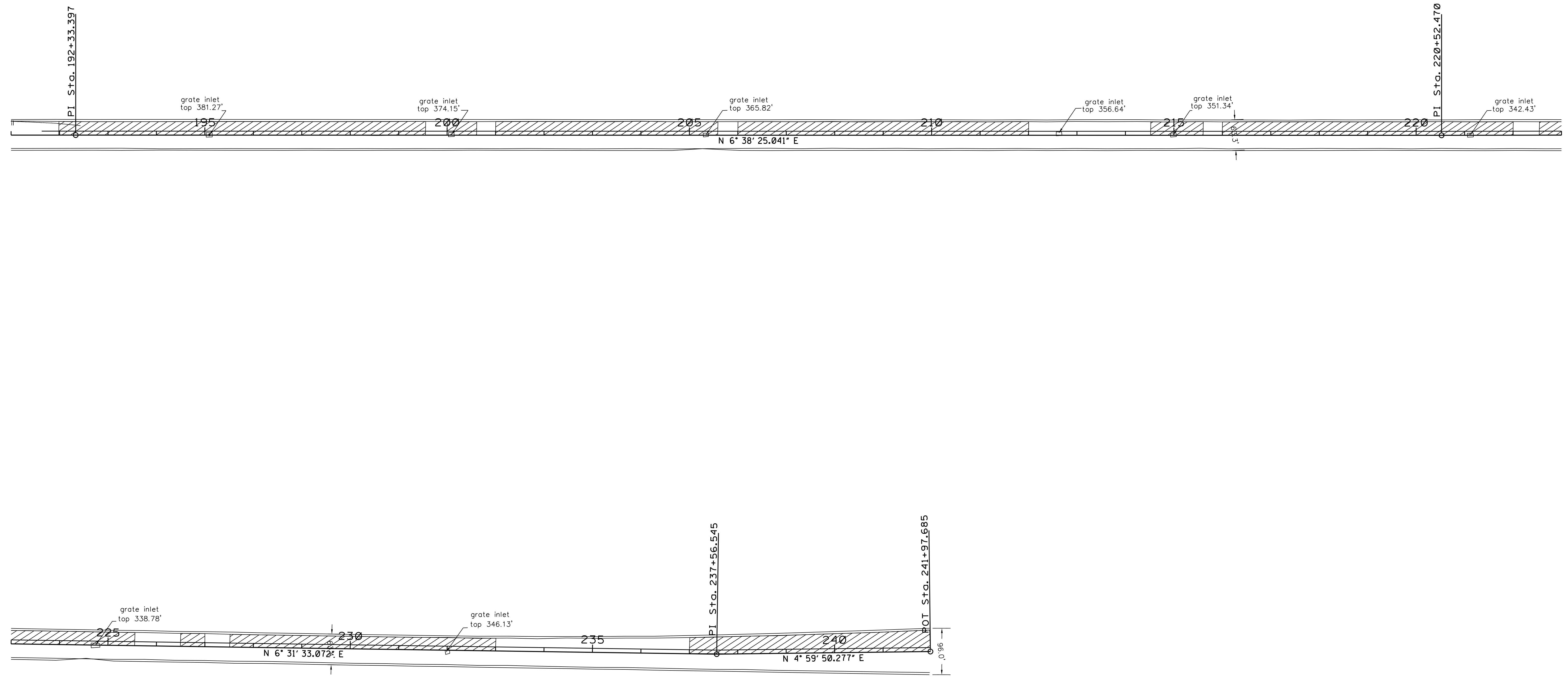
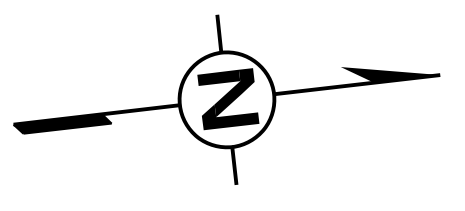

TEMPORARY EROSION CONTROL ITEMS	UNITS	SYMBOL	TOTALS
SILT FENCE	L.F.	—SF—	
SUPER SILT FENCE	L.F.	—SSF—	
WATTLES, 12"	L.F.		
WATTLES, 20"	L.F.		
TRIANGULAR SILT DIKE	L.F.		
SANDBAGS	L.F.		
RIPRAP	TON		
EROSION CHECKS	BALE		
TYPE D SILT BASINS	EACH		

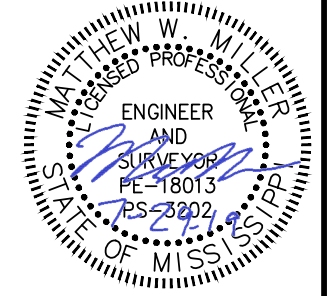
MISSISSIPPI DEPARTMENT OF TRANSPORTATION	
CARROLL COUNTY SECTION 5 PLAN VIEW	
	
PROJ. NO.: HSIP-0055-02(250) COUNTY: CARROLL	
WORKING NUMBER ECP28	SHEET NUMBER 78
FILENAME: <u>ecp28.dgn</u> DESIGN TEAM: <u>GUEST</u> CHECKED: <u>MM</u> DATE: <u>7/8/19</u>	

7/29/2019 4:37 PM ECP28.dgn

PLAN DIVISION MISSISSIPPI DEPARTMENT OF TRANSPORTATION

INSTRUCTIONS FOR COMPLETING THE VEGETATION SCHEDULE

STATE	PROJECT NO.
MISS.	HSIP-0055-02(250)

TOPSOIL - THE NEED FOR TOPSOIL IS DETERMINED FROM THE ORIGINAL SOIL PROFILE BORINGS OR FIELD INSPECTION. IF NOT NEEDED TOPSOIL WILL NOT APPEAR ON SCHEDULE. IF EXTREMELY ACID SOILS ARE ENCOUNTERED 8" THICK TOPSOIL IS NORMALLY REQUIRED. IF THERE ARE ONLY A FEW CUT SECTIONS INDICATING A NEED FOR TOPSOIL YOU MAY WANT TO LIST STATION LIMITS INSTEAD OF A PERCENT OF THE ACREAGE TO BE SEEDED TO OBTAIN AN ESTIMATED PROPOSAL QUANTITY.

AGRICULTURAL LIMESTONE - NOTE ⑥ BELOW WOULD ONLY BE REQUIRED ON PROJECTS WITHIN EXTREMELY ACID SOIL AREAS.

SERICEA LESPEDEZA - THIS ITEM ⑤ REQUIRED ONLY ON PROJECTS WITH DEEP CUT AND FILL SLOPE (MINIMUM 15' DEPTH).

VEGETATION SCHEDULE

EROSION CONTROL ITEMS		SEASONAL APPLICATIONS-DATES & RATES				REQUIREMENTS
		SPRING & SUMMER		FALL & WINTER		
PAY ITEM NO.	ITEMS	RATES	DATES	RATES	DATES	
211-B001	TOPSOIL FOR SLOPE TREATMENT (LVM)	4" THICK	MARCH 1 TO SEPTEMBER 1	4" THICK	SEPTEMBER 1 TO MARCH 1	TOPSOIL REQUIRED ON SLOPE AREAS (SANDY) AT APPROXIMATE STATION LIMITS LISTED BELOW OR AS DIRECTED BY THE ENGINEER.
225-A001	STANDARD GROUND PREPARATION	PER SQ.YD.	MARCH 1 TO SEPTEMBER 1	PER SQ.YD.	SEPTEMBER 1 TO MARCH 1	GROUND PREPARATION REQUIRED ON AREAS TO RECEIVE SOLID SODDING OR SEEDING, AS APPLICABLE.
⑥ 225-B001	AGRICULTURAL LIMESTONE	1000 LBS./ACRE	MARCH 1 TO SEPTEMBER 1		SEPTEMBER 1 TO MARCH 1	LIMESTONE SHALL BE MECHANICALLY SPREAD UNIFORMLY AND INCORPORATED INTO THE SOIL PRIOR TO PLANTING.
225-A001	COMBINATION FERTILIZER (13-13-13)	250 LBS./ACRE	MARCH 1 TO SEPTEMBER 1		SEPTEMBER 1 TO MARCH 1	FERTILIZER SHALL BE MECHANICALLY SPREAD UNIFORMLY AND INCORPORATED INTO THE SOIL PRIOR TO PLANTING.
① 213-C001	SUPERPHOSPHATE	0.5 TONS/ACRE (EST.)	MARCH 1 TO DECEMBER 1			SUPERPHOSPHATE (FOR BID ITEM PURPOSES).
② 225-A001	SEEDING (BERMUDAGRASS)	80 LBS./ACRE	MARCH 1 TO SEPTEMBER 1		SEPTEMBER 1 TO MARCH 1	SEED REQUIRED ON DISTURBED AREAS. UNHULLED SEED MAY BE REQUIRED DURING THE DORMANT SEASON AS DIRECTED.
② 225-A001	SEEDING (BAHIAGRASS)	80 LBS./ACRE	MARCH 1 TO SEPTEMBER 1		SEPTEMBER 1 TO MARCH 1	SEED REQUIRED ON DISTURBED AREAS.
③ 225-A001	SEEDING (TALL FESCUE)			100 LBS./ACRE	NOVEMBER 1 TO APRIL 1	SEED REQUIRED ON DISTURBED AREAS.
⑤ 225-A001	SEEDING (SERICEA LESPEDEZA)	25 LBS./ACRE	MARCH 1 TO SEPTEMBER 1	25 LBS./ACRE	SEPTEMBER 1 TO MARCH 1	SEE NOTE ⑤ BELOW.
③ 225-A001	SEEDING (CRIMSON CLOVER)			20 LBS./ACRE	AUGUST 1 TO APRIL 1	SEED REQUIRED ON DISTURBED AREAS.
225-C001	MULCH - VEGETATIVE MULCH	2 TONS ACRE (EST.)	MARCH 1 TO SEPTEMBER 1	2 TONS/ACRE (EST.)	SEPTEMBER 1 TO MARCH 1	THE ENGINEER WILL DESIGNATE THE RATES OF APPLICATION (SEE SUBSECTION 215.03.3).
216-A001	SOLID SODDING	PER SQ.YD.	MARCH 1 TO SEPTEMBER 1	PER SQ. YD.	SEPTEMBER 1 TO MARCH 1	SOLID SOD REQUIRED ON AREAS SPECIFIED IN THE CONTRACT OR BY THE ENGINEER.
219-A001	WATERING	20 GALS./S.Y. (EST.)	MARCH 1 TO SEPTEMBER 1	20 GALS. S.Y. (EST.)	SEPTEMBER 1 TO MARCH 1	TO BE USED AS DIRECTED IN THE PLANTING AND ESTABLISHING SOLID SOD.
④ 220-A001	INSECT PEST CONTROL	PER ACRE		PER ACRE		SEE SECTION 220.
	TEMPORARY EROSION CONTROL ITEMS					
226-A001	LIGHT GROUND PREPARATION	PER SQ.YD.		PER SQ.YD.		APPROXIMATELY HALF SQ. YD. STANDARD GROUND PREPARATION
226-A001	COMBINATION FERTILIZER (13-13-13)	250 LBS./ACRE				QUANTITY BASED ON LIGHT GROUND PREPARATION
226-A001	SEEDING (BROWN TOP MILLET)	20 LBS./ACRE	APRIL 1 TO AUGUST 31			QUANTITY BASED ON LIGHT GROUND PREPARATION
226-A001	SEEDING (RYE GRASS)			25 LBS./ACRE	SEPTEMBER 1 TO MARCH 31	QUANTITY BASED ON LIGHT GROUND PREPARATION
226-A001	SEEDING (OATS)			90 LBS./ACRE	SEPTEMBER 1 TO DECEMBER 15	QUANTITY BASED ON LIGHT GROUND PREPARATION
226-A001	VEGETATIVE MATERIAL FOR MULCH	2 TON /ACRE (EST.)		2 TON /ACRE (EST.)		QUANTITY BASED ON LIGHT GROUND PREPARATION

- ① ALL AREAS THAT HAVE BEEN VEGETATED, UNDER THIS CONTRACT FOR AT LEAST (60) SIXTY DAYS, SHALL RECEIVE ADDITIONAL APPLICATION(S) OF FERTILIZER(S) OF THE TYPE(S) AND RATE(S) OF APPLICATIONS AS DETERMINED BY SOIL TESTS OR AS DIRECTED DURING THE GROWING SEASONS THE CONTRACT IS IN FORCE. GROUND PREPARATION WILL NOT BE REQUIRED FOR THE ADDITIONAL APPLICATIONS. PAYMENT FOR ALL FERTILIZERS ACCEPTABLY APPLIED AS AN ADDITIONAL APPLICATION(S) WILL BE MADE IN ACCORDANCE WITH SUPERPHOSPHATE BID ITEM 213-C001.
- ② PROPOSAL QUANTITIES ESTIMATED ON THE BASIS THAT 100% OF THE ACREAGE WILL BE SEEDED.
- ③ PROPOSAL QUANTITIES ESTIMATED ON THE BASIS THAT 50% OF THE ACREAGE WILL BE SEEDED.
- ④ QUANTITY ESTIMATED ON THE BASIS 50% OF THE ACREAGE VEGETATED MAY REQUIRE TREATMENT.
- ⑤ SOW, IN ADDITION TO OTHER SPECIFIED SEEDS, ON HIGH FILL AND BACKSLOPE AREAS SELECTED BY ENGINEERS DURING CONSTRUCTION. PROPOSAL QUANTITIES ESTIMATED ON THE BASIS THAT 50% OF THE ACREAGE WILL BE SEEDED.
- ⑥ THE ACTUAL RATE/ACRE TO BE DETERMINED BY SOIL TEST DURING CONSTRUCTION.

7/29/2019 4:38 PM VS-1.dgn

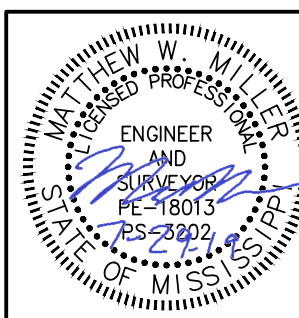
REVISION		BY		DATE		MISSISSIPPI DEPARTMENT OF TRANSPORTATION DISTRICT 3 OR 5 VEGETATION SCHEDULE RURAL - GRADE & DRAIN AND/OR BRIDGES, EXCLUDING MS DELTA PROJ. NO.: HSIP-0055-02(250) COUNTY: COPIAH, HOLMES, CARROLL FILENAME: VS-1.dgn DESIGN TEAM GUEST CHECKED MM DATE 7/8/19		 WORKING NUMBER VS-1 SHEET NUMBER 79

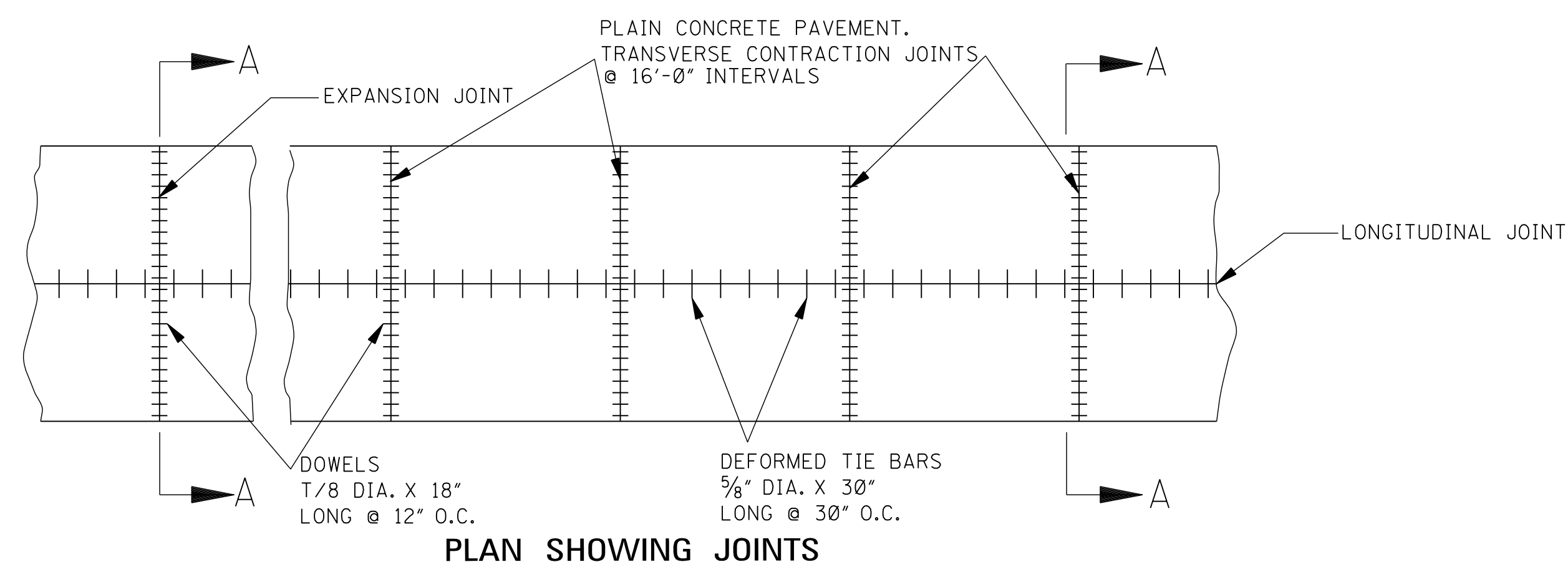

PLAN SHOWING JOINTS

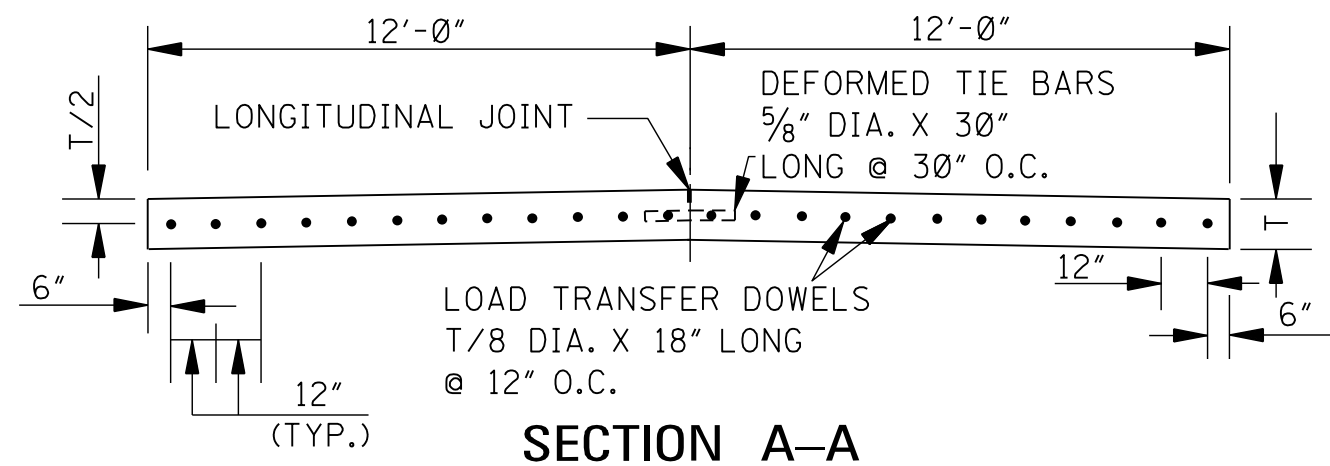

SECTION A-A

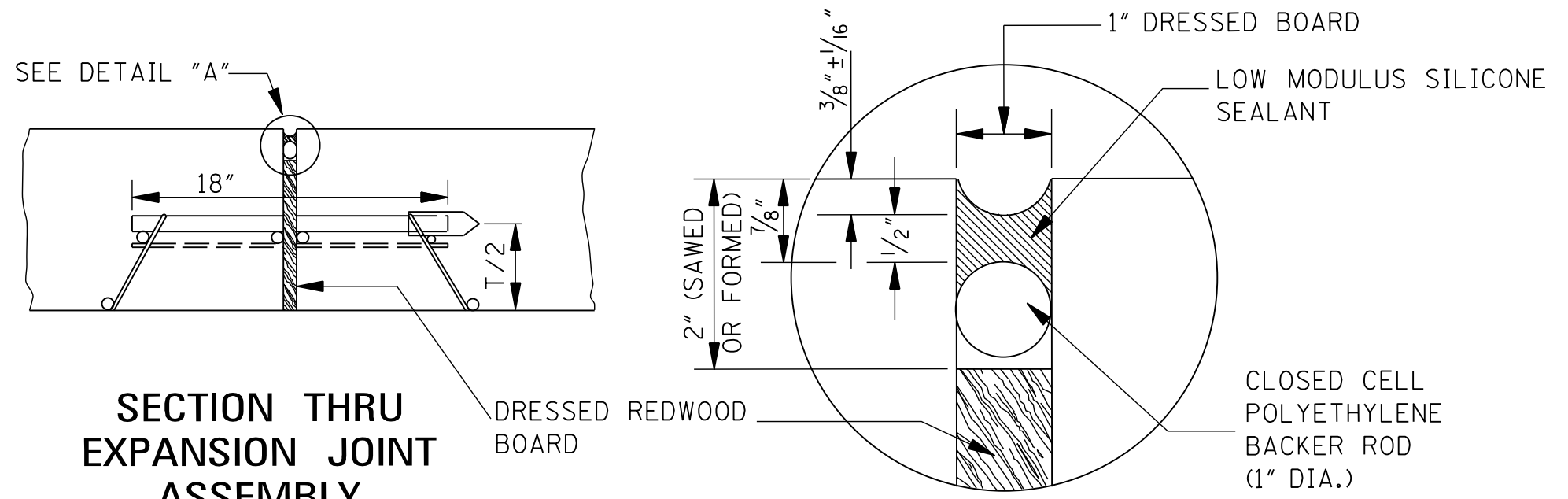

DETAIL "A"

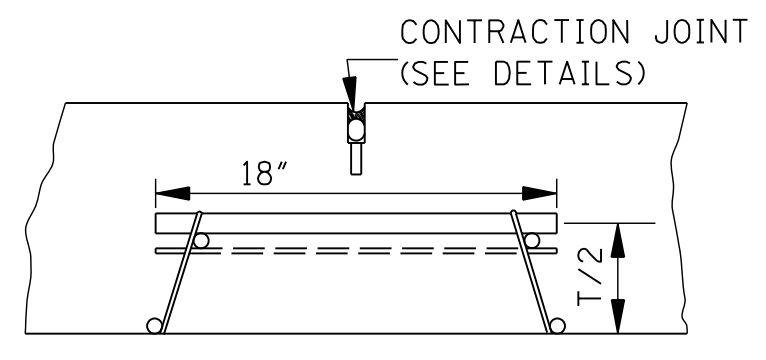

SECTION THRU CONTRACTION JOINT ASSEMBLY

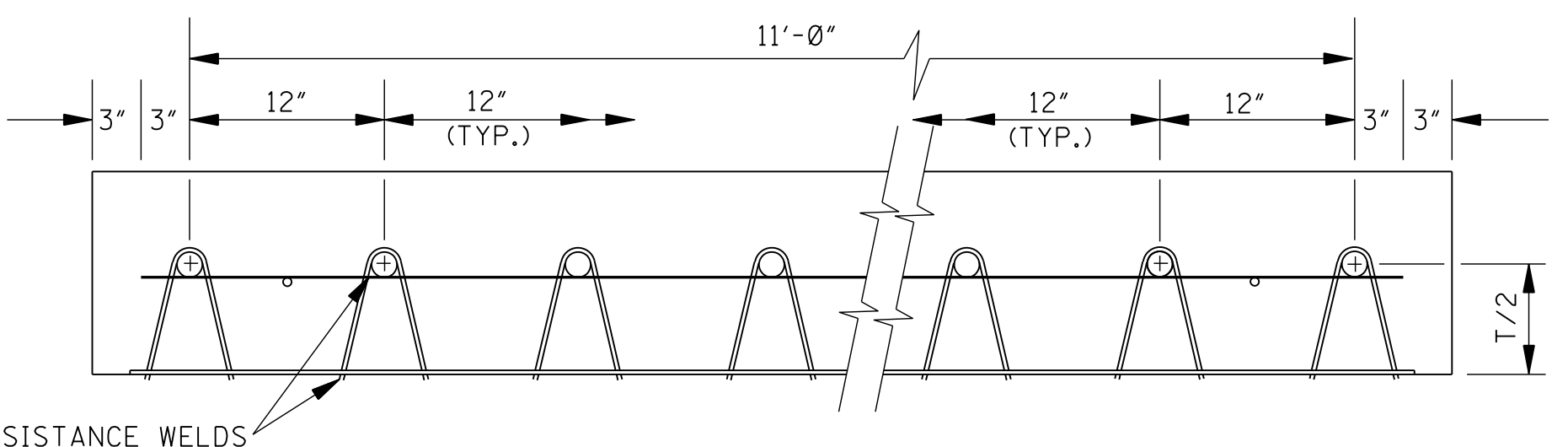

ELEVATION OF LOAD TRANSFER ASSEMBLY

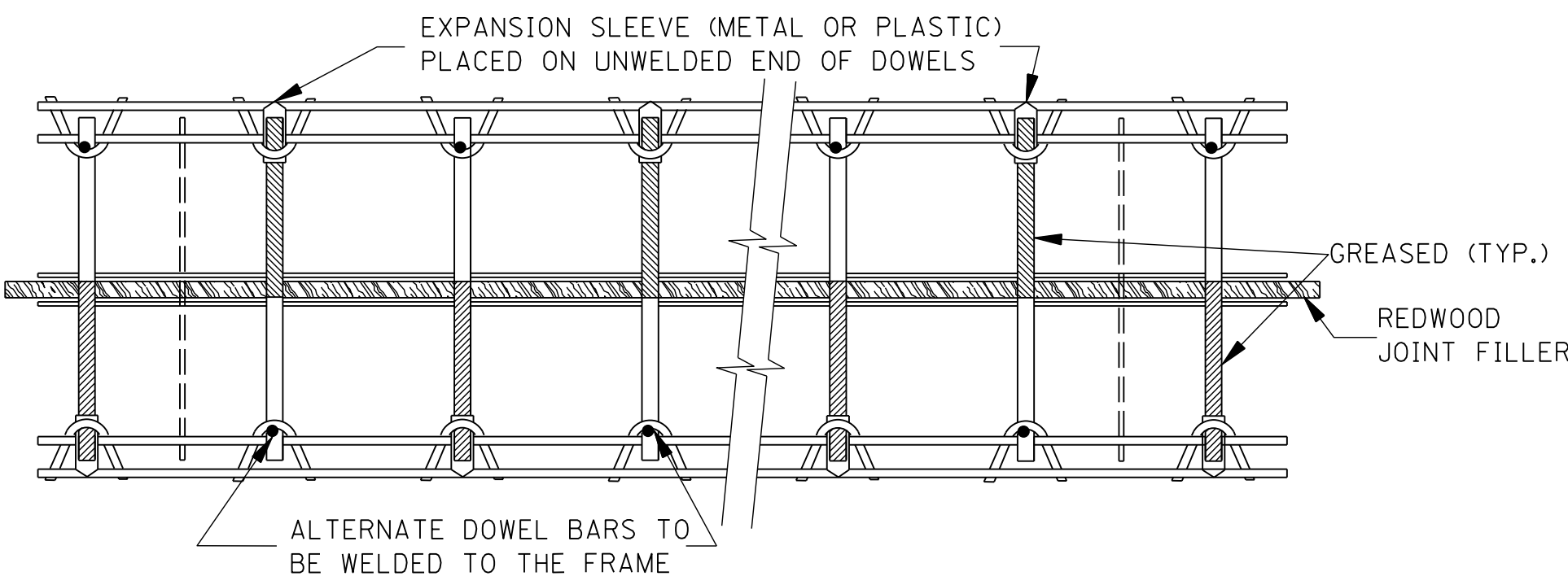

PLAN OF LOAD TRANSFER ASSEMBLY (EXPANSION JOINT)

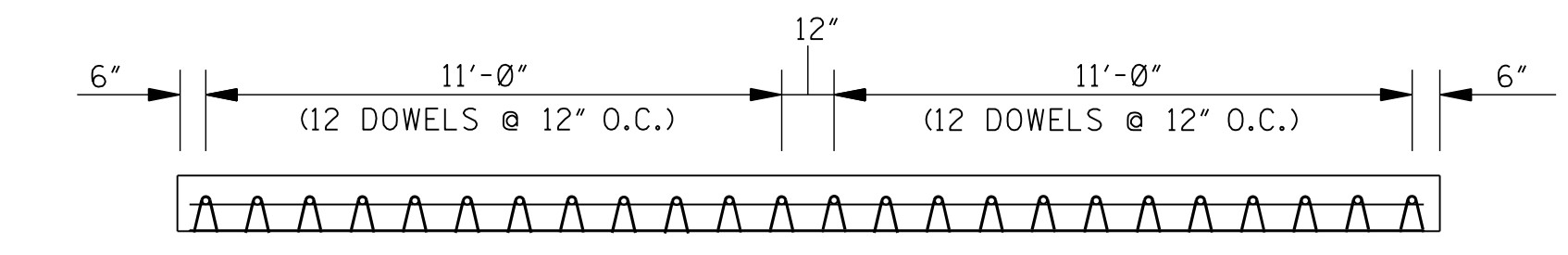

PLACEMENT OF ASSEMBLIES IN 24'-0" WIDTH PAVEMENT

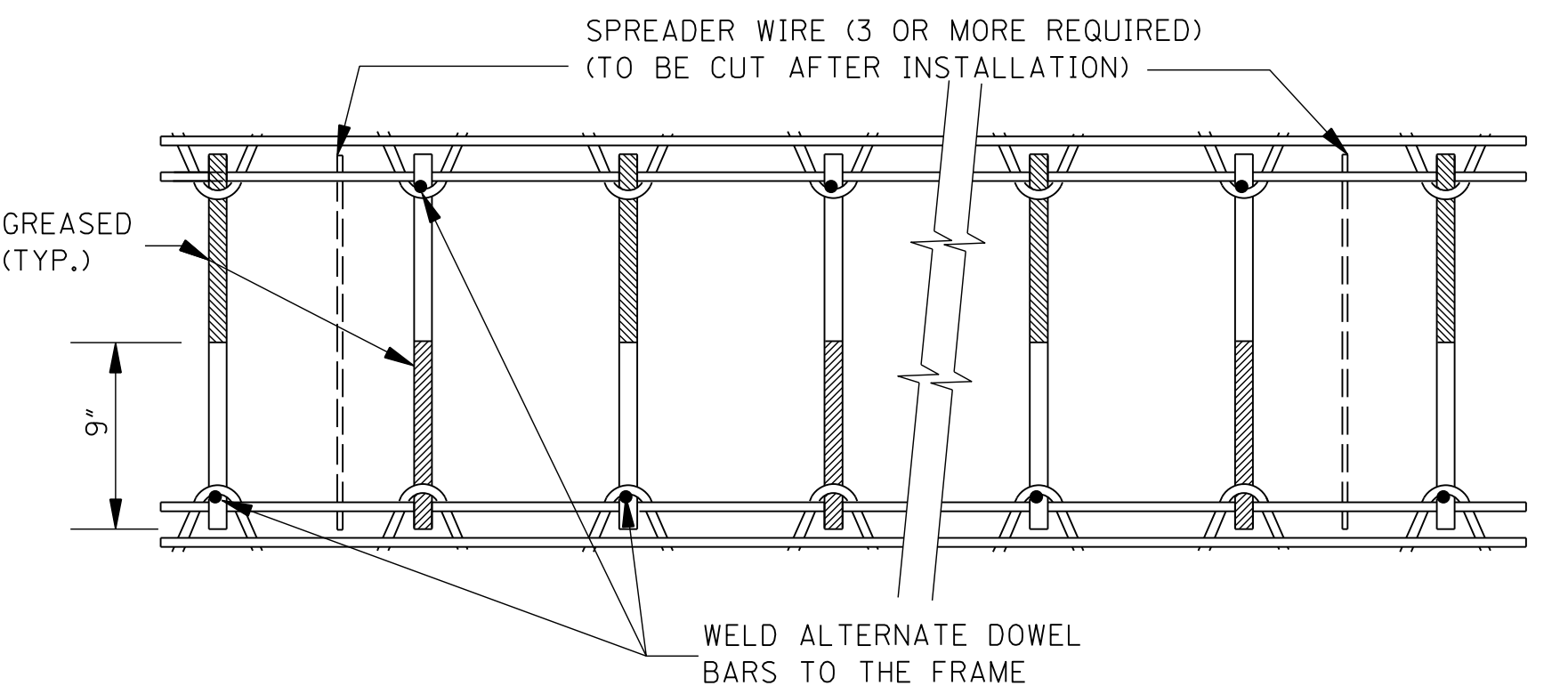

PLAN OF LOAD TRANSFER ASSEMBLY (CONTRACTION JOINT)

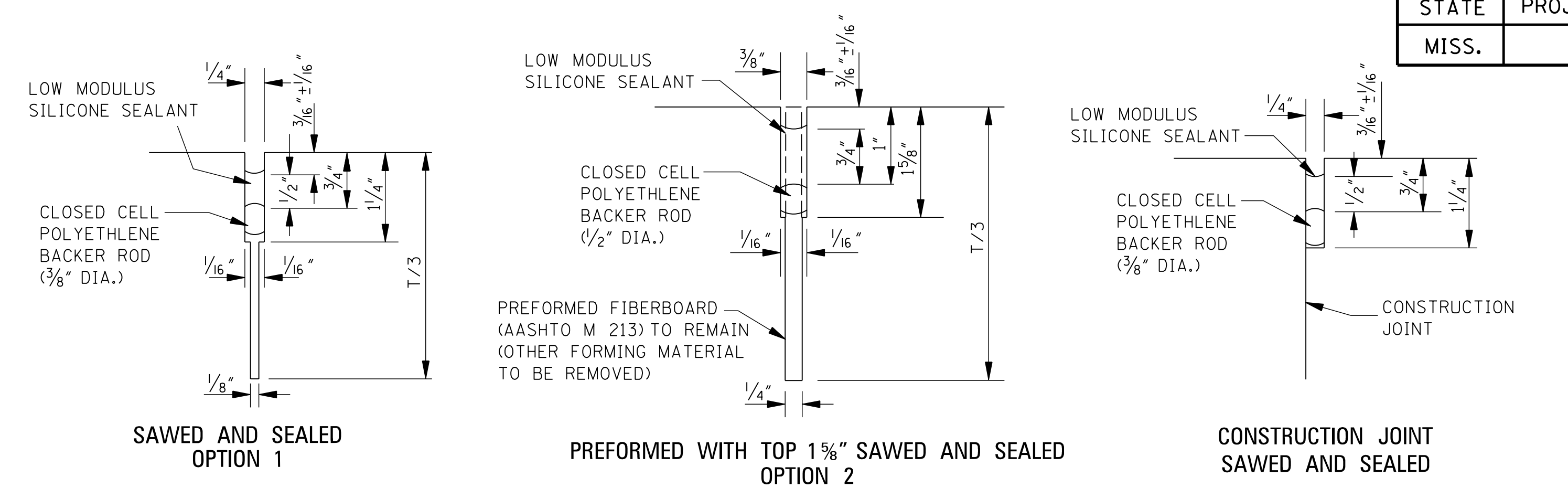

LONGITUDINAL JOINTS

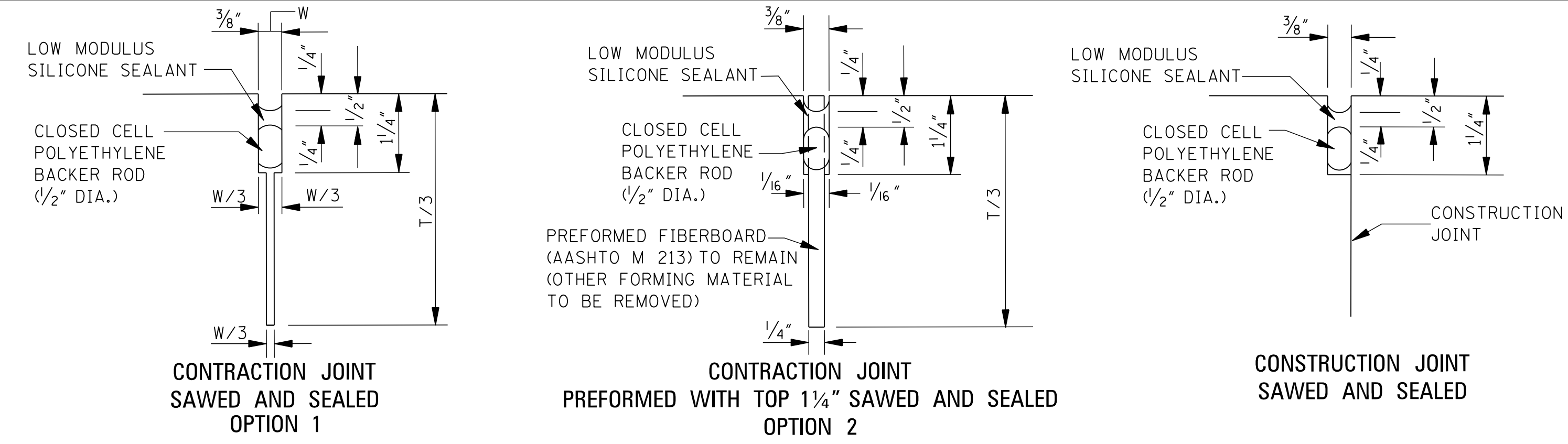

TRANSVERSE JOINTS

GENERAL NOTES:

- DOWEL BAR SPECIFICATIONS: AASHTO M 31 GRADE 60.
TOLERANCES: THE PERMISSIBLE VARIATION IN STRAIGHTNESS SHALL BE A MAXIMUM OF 0.075" IN THE LENGTH OF THE DOWEL. THE TOLERANCES IN THE LENGTH SHALL BE +/- 0.25".
THE MAXIMUM PERMISSIBLE ALIGNMENT VARIATION SHALL BE 0.25" IN THE LENGTH OF THE DOWEL IN EACH PLANE, BOTH HORIZONTALLY AND VERTICALLY.
COATING: DOWELS SHALL BE SHOP PAINTED FULL LENGTH WITH ONE OF THE FOLLOWING PAINTS AS PER SPECIFICATION: (1) FEDERAL SPECIFICATION TT-P-645, (2) FEDERAL SPECIFICATION TT-P-31D, OR (3) STEEL STRUCTURES PAINTING COUNCIL SPECIFICATION SSPC-PAIN II.
- ASSEMBLY FRAME SPECIFICATIONS: AASHTO M 32.
FRAME WIRE SIZES: ALL FRAME WIRES SHALL BE W5.5 OR GREATER EXCEPT THE SPREADER WIRES WHICH SHALL BE W3 OR GREATER.
- ANCHOR PINS: THE ASSEMBLY SHALL BE SECURED TO CEMENT TREATED OR ASPHALT BASE WITH RASET, HILTI, POWERS, OR EQUIVALENT TIES (MINIMUM OR 8 PER 12 FT. SECTION. -- 3 ON EACH) OR OTHER APPROVED METHODS. THE CONTRACTOR SHALL BE RESPONSIBLE FOR SECURING THE ENTIRE ASSEMBLY IN SUCH A MANNER AS TO PREVENT DISPLACEMENT.
- FOR CONSIDERATION OF USE OF OTHER LOAD TRANSFER ASSEMBLIES, THE CONTRACTOR SHALL PROVIDE DRAWINGS TO THE ENGINEER FOR APPROVAL.
- PREFORMED FILLER IS NOT AN ALTERNATIVE FOR REDWOOD FILLER AT EXPANSION JOINTS UNLESS SPECIFICALLY REQUIRED ON THE PLANS.

BY		MISSISSIPPI DEPARTMENT OF TRANSPORTATION ROADWAY DESIGN DIVISION STANDARD PLAN	
REVISION		<p>CONCRETE PAVEMENT JOINTS</p>	
DATE			
ISSUE DATE: AUGUST 01, 2017		WORKING NUMBER PJ-1	SHEET NUMBER 6004

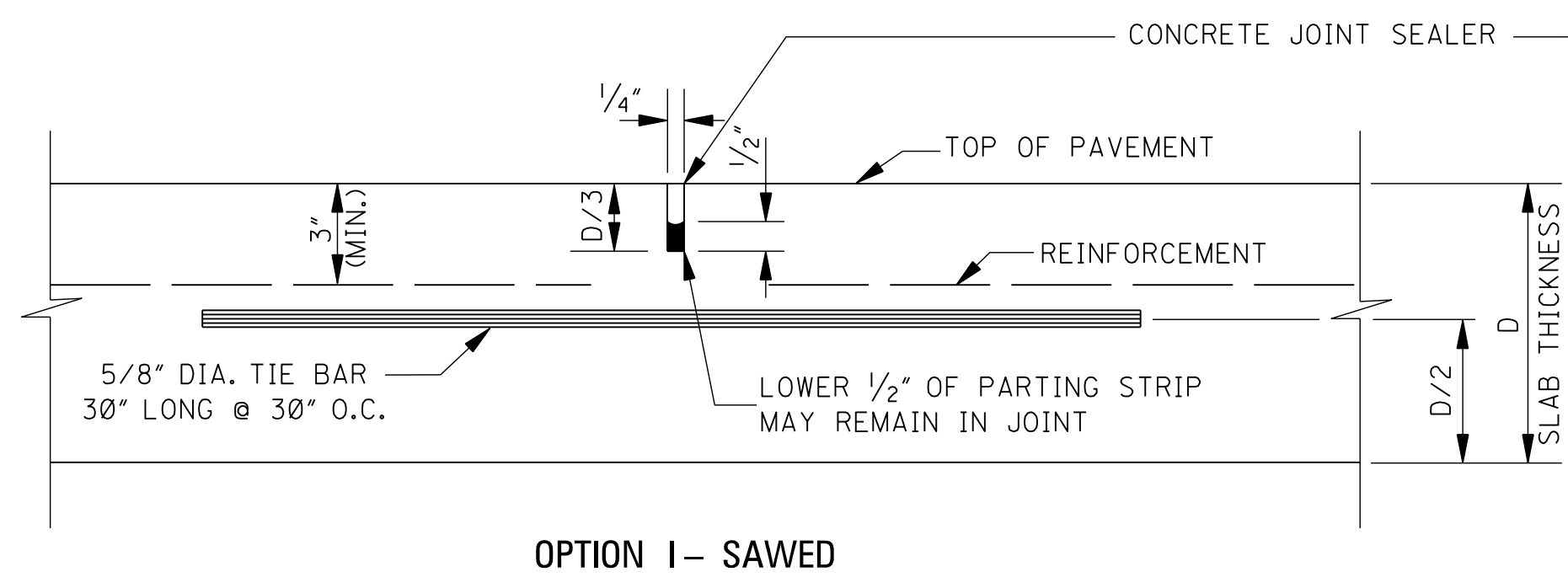

OPTION I - SAWED

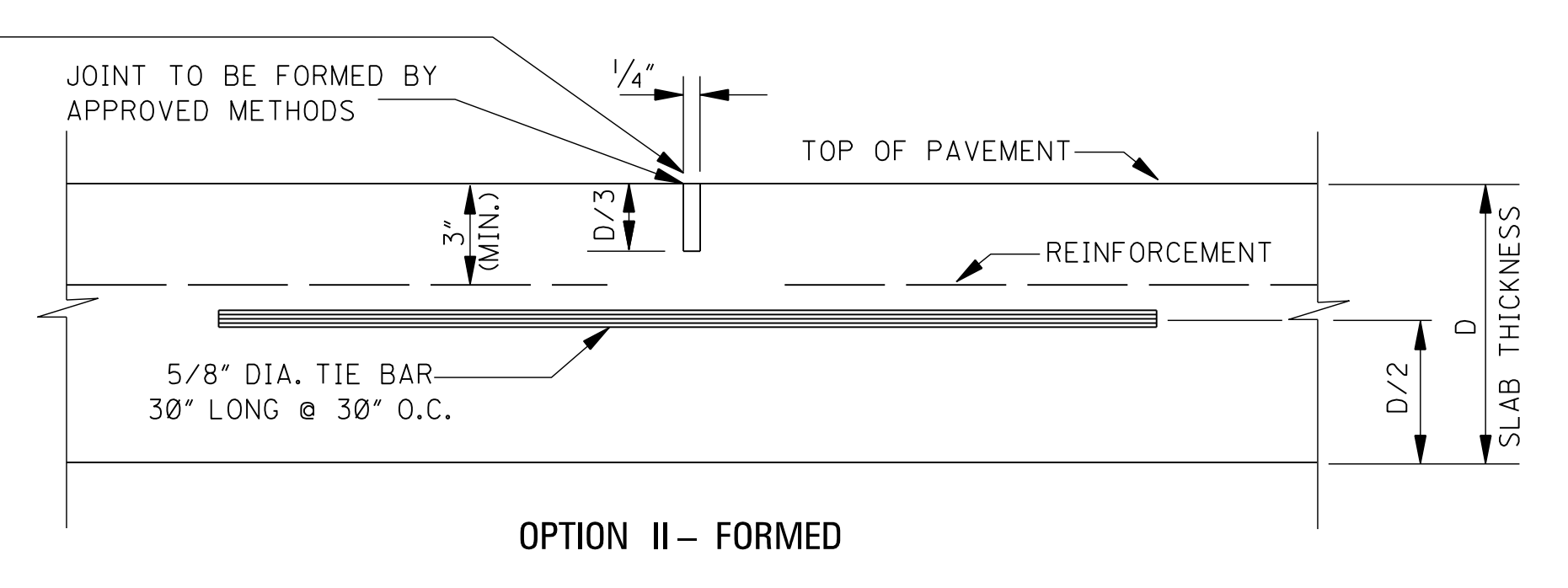

OPTION II - FORMED

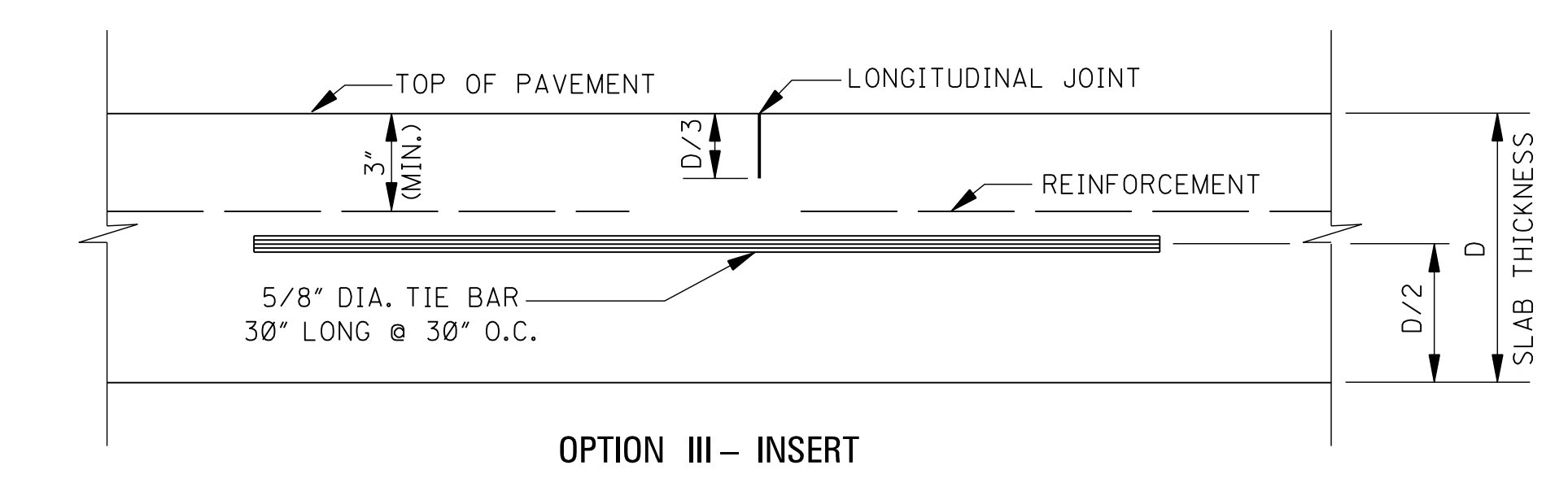

OPTION III - INSERT

DETAILS OF LONGITUDINAL JOINTS FOR CONVENTIONALLY REINFORCED CONCRETE PAVEMENT

NOTE: A LONGITUDINAL WEAKENED PLANE JOINT MAY BE FORMED BY PLACEMENT OF A CONTINUOUS STRIP OF POLYETHYLENE OR OTHER APPROVED MATERIAL. WITH THIS TYPE OF INSERT IT IS NOT REQUIRED TO SAW OR SEAL THE LONGITUDINAL JOINT.

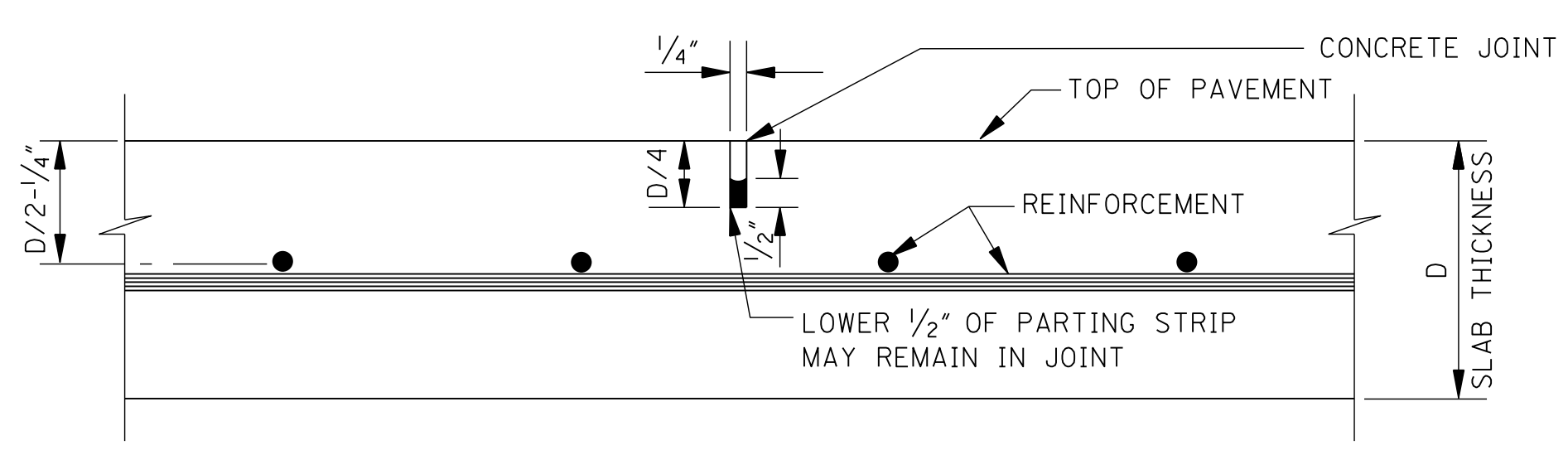

OPTION I - SAWED

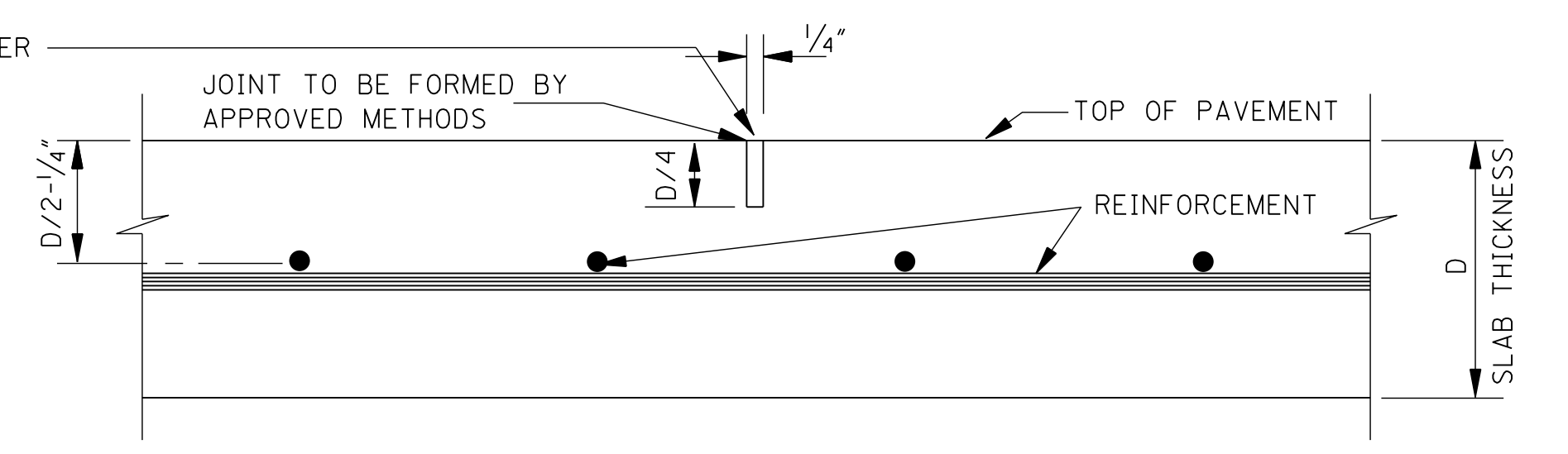

OPTION II - FORMED

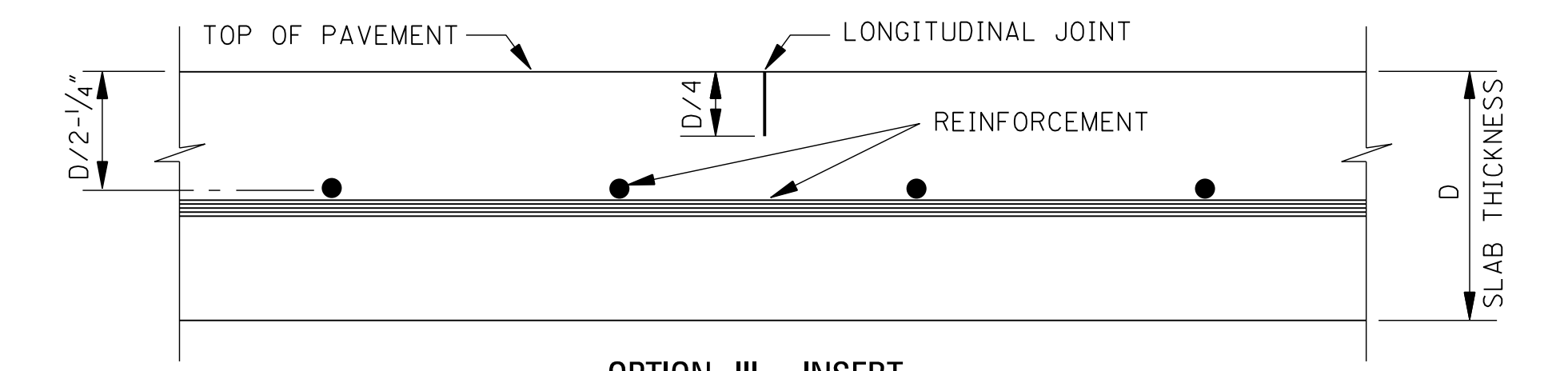

OPTION III - INSERT

DETAILS OF LONGITUDINAL JOINTS FOR CONTINUOUSLY REINFORCED CONCRETE PAVEMENT

NOTE: A LONGITUDINAL WEAKENED PLANE JOINT MAY BE FORMED BY PLACEMENT OF A CONTINUOUS STRIP OF POLYETHYLENE OR OTHER APPROVED MATERIAL. WITH THIS TYPE OF INSERT IT IS NOT REQUIRED TO SAW OR SEAL THE LONGITUDINAL JOINT.

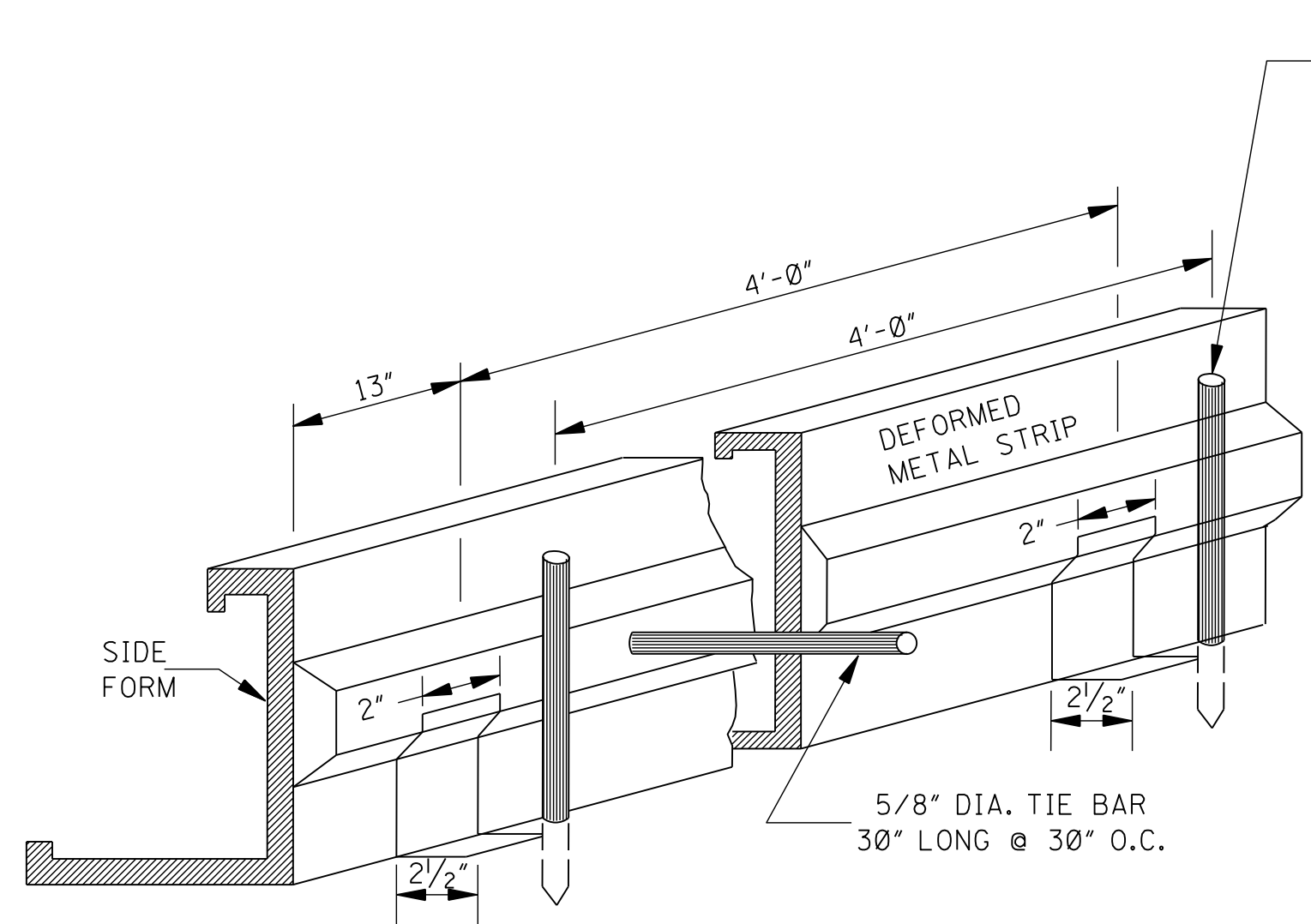

LONGITUDINAL CONSTRUCTION JOINT

NOTE: FOR CONSIDERATION OF OTHER TYPES OF FORMS, THE CONTRACTOR SHALL SUBMIT DRAWINGS TO THE ENGINEER FOR APPROVAL.

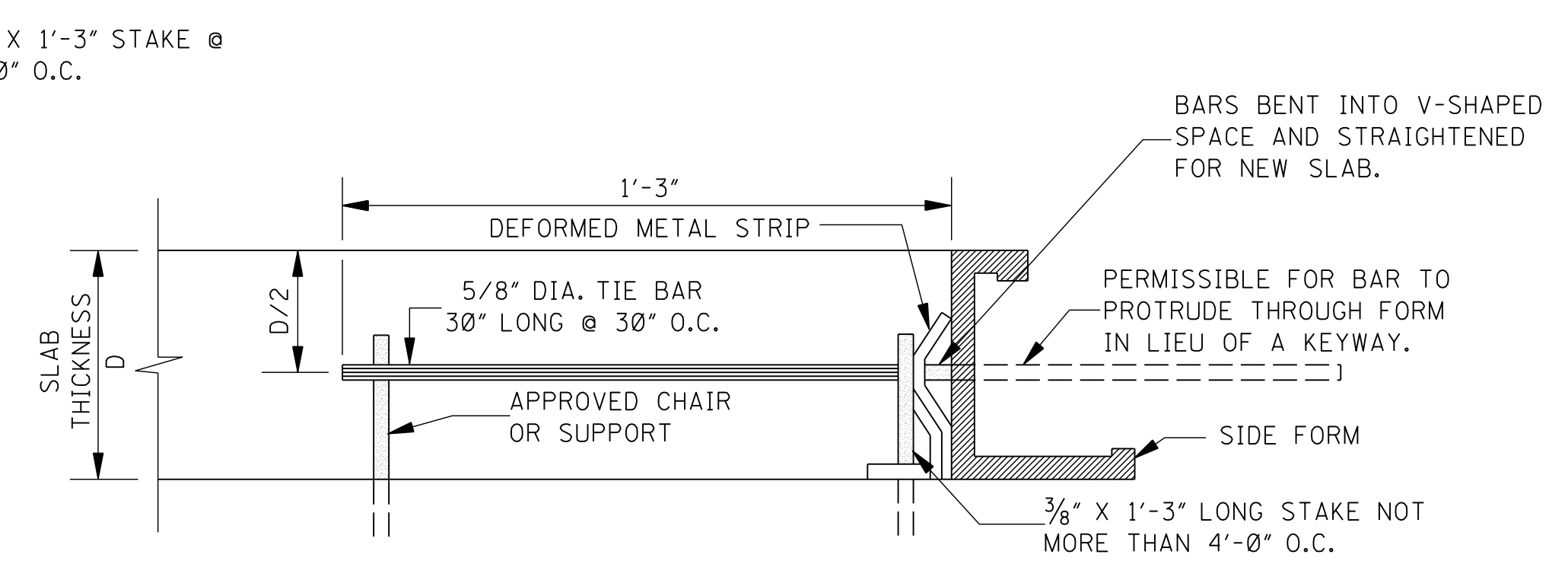

LONGITUDINAL CONSTRUCTION JOINT

JOINT MAY BE FORMED OR TOOLED BY AN APPROVED METHOD; OR FORMED WITH A PARTING STRIP AND SAWED TO A DEPTH OF (D/4 - 1/2"); OR SAWED TO A DEPTH OF 1/2" WITHOUT THE INSERTION OF PARTING STRIP.

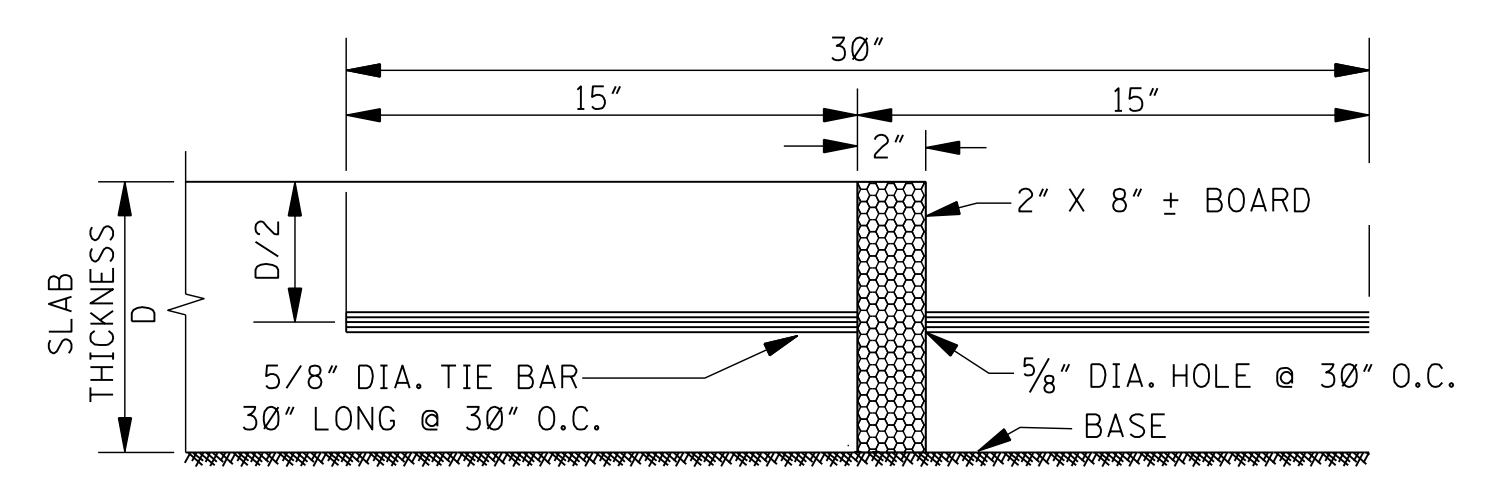

NOTE: PLACE FORM BOARD, INSERT AND VIBRATE TIE BARS IMMEDIATELY FOLLOWING THE TRAILING FORM OF A SLIP-FORM PAVER. REMOVE BOARD AFTER PLACEMENT OF TIE BARS.

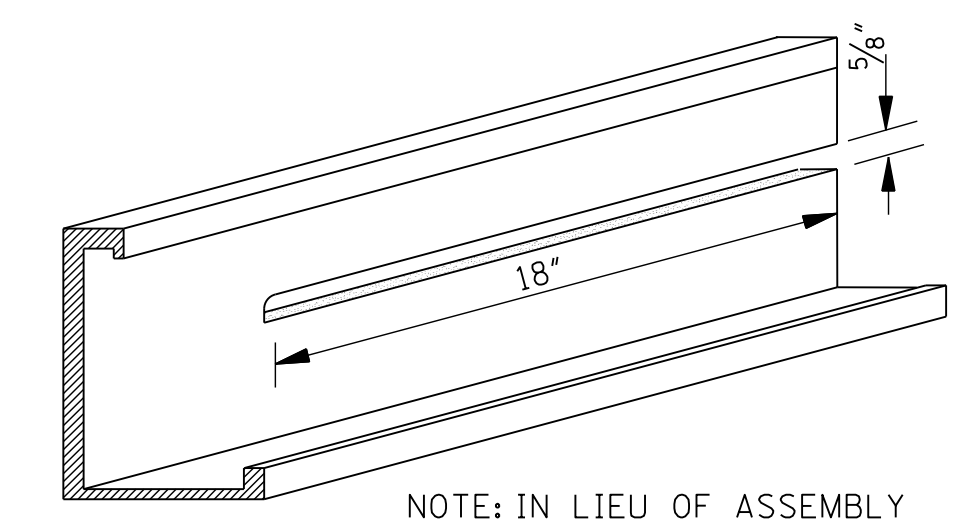

NOTE: IN LIEU OF ASSEMBLY SHOWN AT LEFT, THE LAST 18" OF TRAILING FORMS MAY BE SLOTTED AS SHOWN.

LONGITUDINAL CONSTRUCTION JOINT FOR SLIP FORM PAVEMENT

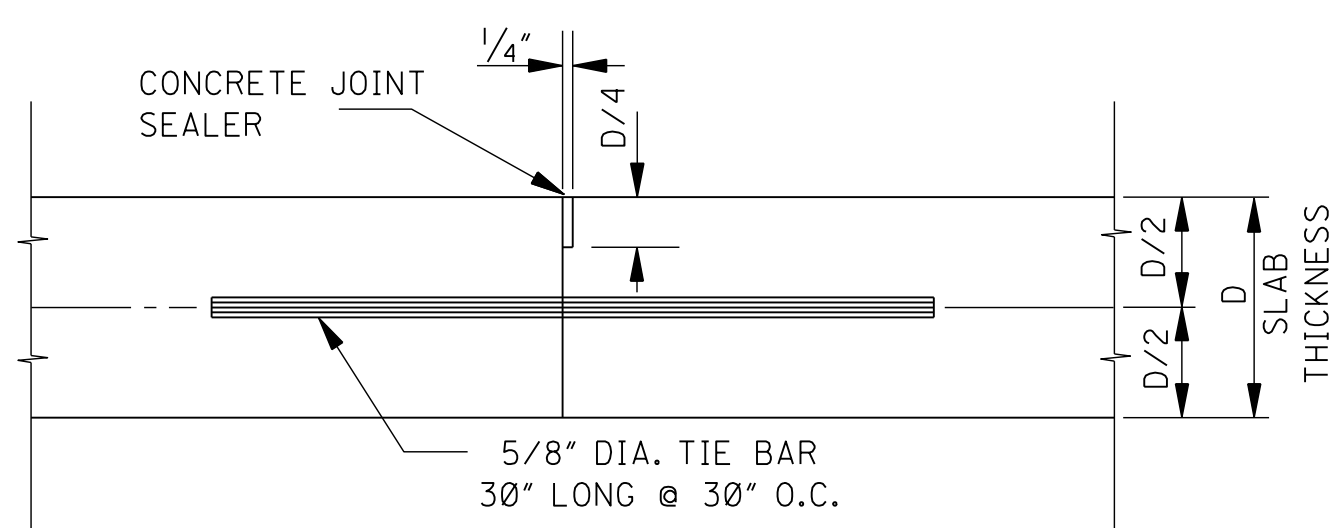

LONGITUDINAL CONSTRUCTION JOINT

JOINT MAY BE FORMED OR TOOLED BY AN APPROVED METHOD; OR FORMED WITH A PARTING STRIP AND SAWED TO A DEPTH OF (D/4 - 1/2"); OR SAWED TO A DEPTH OF 1/2" WITHOUT THE INSERTION OF PARTING STRIP.

BY	MISSISSIPPI DEPARTMENT OF TRANSPORTATION ROADWAY DESIGN DIVISION STANDARD PLAN
REVISION	CONCRETE PAVEMENT JOINTS (LONGITUDINAL)
DATE	ISSUE DATE: AUGUST 01, 2017

GENERAL NOTES:

1. "J-HOOK" CONFIGURATION SILT FENCE APPLICATIONS SHOULD BE USED IN CONJUNCTION WITH PERIMETER SILT FENCE WHEN STORMWATER RUNOFF IS IN TWO DIRECTIONS (DOWN A FILL SLOPE AND DOWN GRADIENT ALONG THE RIGHT-OF-WAY).
2. "SMILE CONFIGURATION" APPLICATIONS SHOULD BE USED AS PERIMETER SILT FENCE WHEN THERE IS ONE-DIRECTIONAL FLOW DOWN A SLOPE.
3. SAND BAGS CAN BE USED AS DIVERSION BERMS TO PREVENT SEDIMENT FROM BEING WASHED ONTO OR ACROSS HARD SURFACES, OR TO HELP SLOW SHEET FLOW VELOCITY WHEN DRAINING AWAY FROM HARD SURFACES.
4. FOR SHORTER SLOPES AND/OR SLOPES THAT ARE LESS STEEP, DIVERSION BERMS CAN BE USED TO SAFELY CONVEY STORMWATER AWAY FROM OR AROUND A DENUDED AREA. THEY CAN BE CONSTRUCTED USING MANUFACTURED SILT DIKE OR BY CONSTRUCTING A TEMPORARY EARTH BERM AND TRENCH WITH GEOTEXTILE OR POLYETHYLENE SHEETING PROTECTION.
5. TEMPORARY DEWATERING STRUCTURES CAN BE USED DURING CULVERT CONSTRUCTION, STREAM DIVERSIONS, OR OTHER CONSTRUCTION ACTIVITIES WHERE TURBID WATERS NEED TO BE CLARIFIED BEFORE RELEASE.
6. THE ABUTMENT SLOPE TOE BERM SHALL BE 3 FT. TALL. THE BERM MAY BE CONSTRUCTED WITH ROCK IN ACCORDANCE WITH REQUIREMENTS FOR ROCK DITCH CHECKS ON WK. NO. ECD-8 OR WITH SOIL IN ACCORDANCE WITH WK. NO. BAS-A. IF BERM IS USED, IT MUST BE GRASSED.

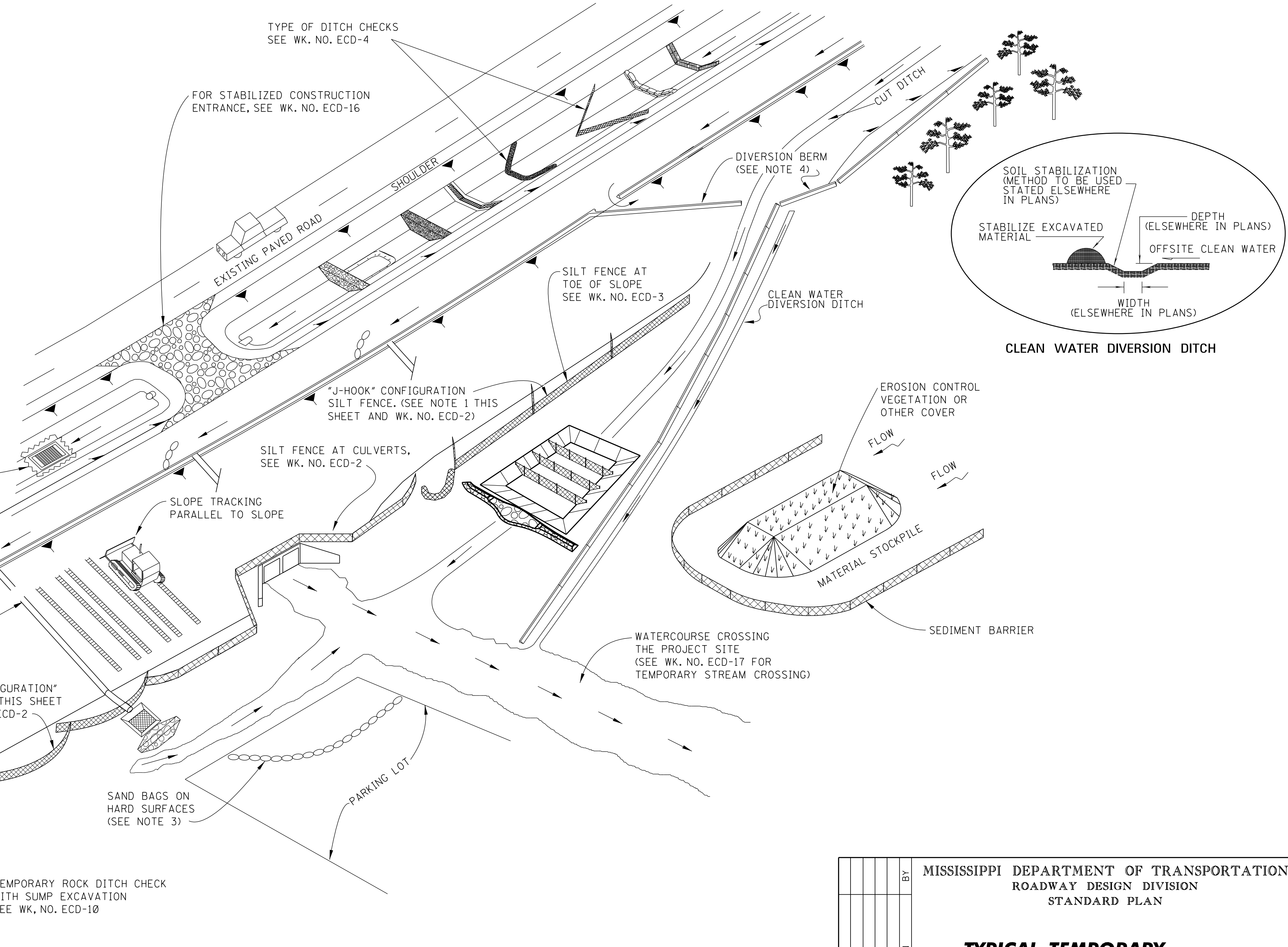

ABUTMENT SLOPE TOE BERM
SEE NOTE 6.

FOR TURBIDITY CURTAIN
SEE WK. NO. ECD-20

FOR TEMPORARY STREAM
CROSSING SEE WK.
NO. ECD-17.

BY	MISSISSIPPI DEPARTMENT OF TRANSPORTATION ROADWAY DESIGN DIVISION STANDARD PLAN
REVISION	
DATE	ISSUE DATE: AUGUST 01, 2017

**TYPICAL TEMPORARY
EROSION / SEDIMENT
CONTROL APPLICATIONS**

MDOT
MISSISSIPPI DEPARTMENT OF TRANSPORTATION

WORKING NUMBER
ECD-1
SHEET NUMBER
6101

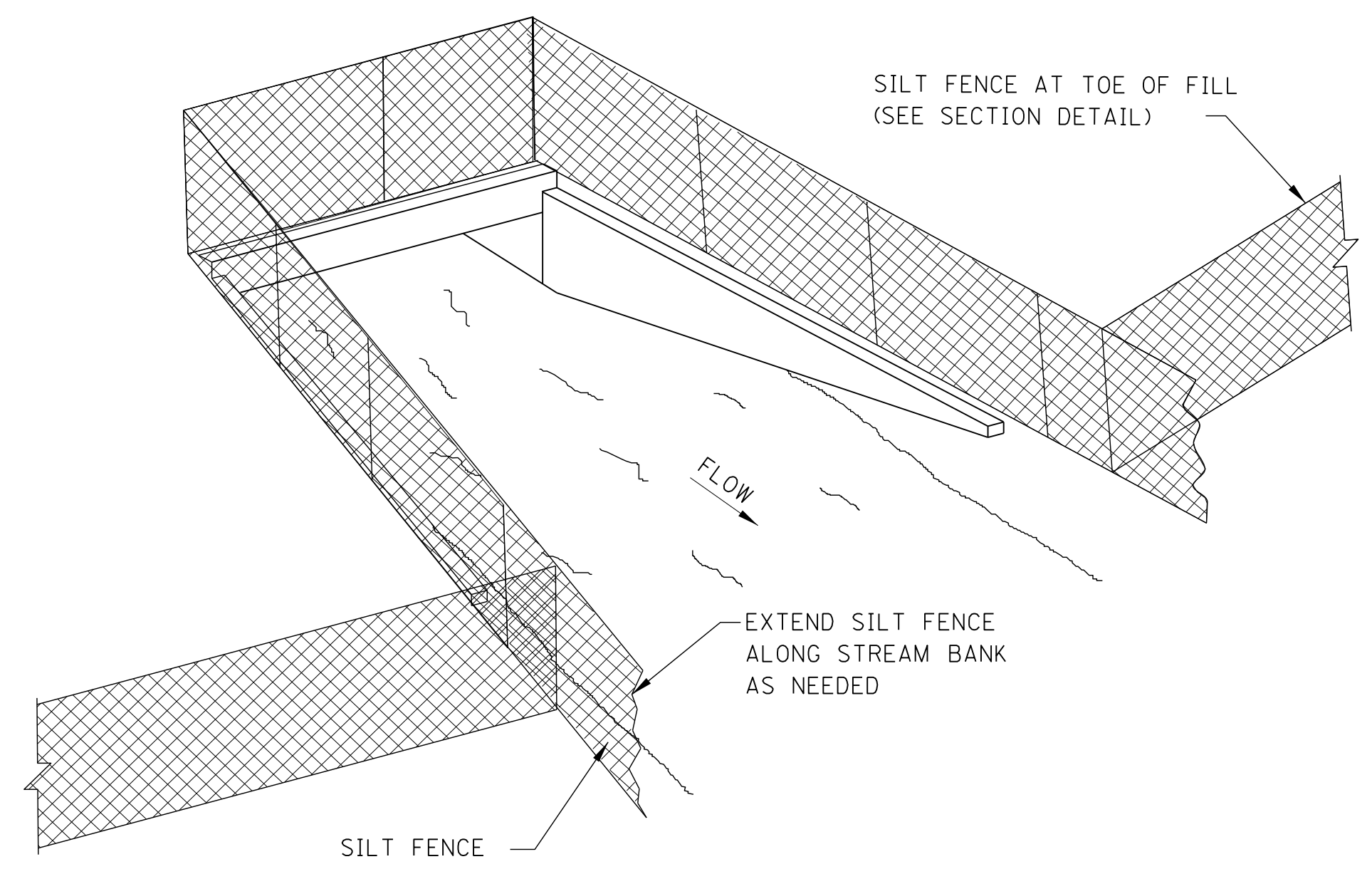

SEDIMENT BARRIER AT CROSS DRAIN

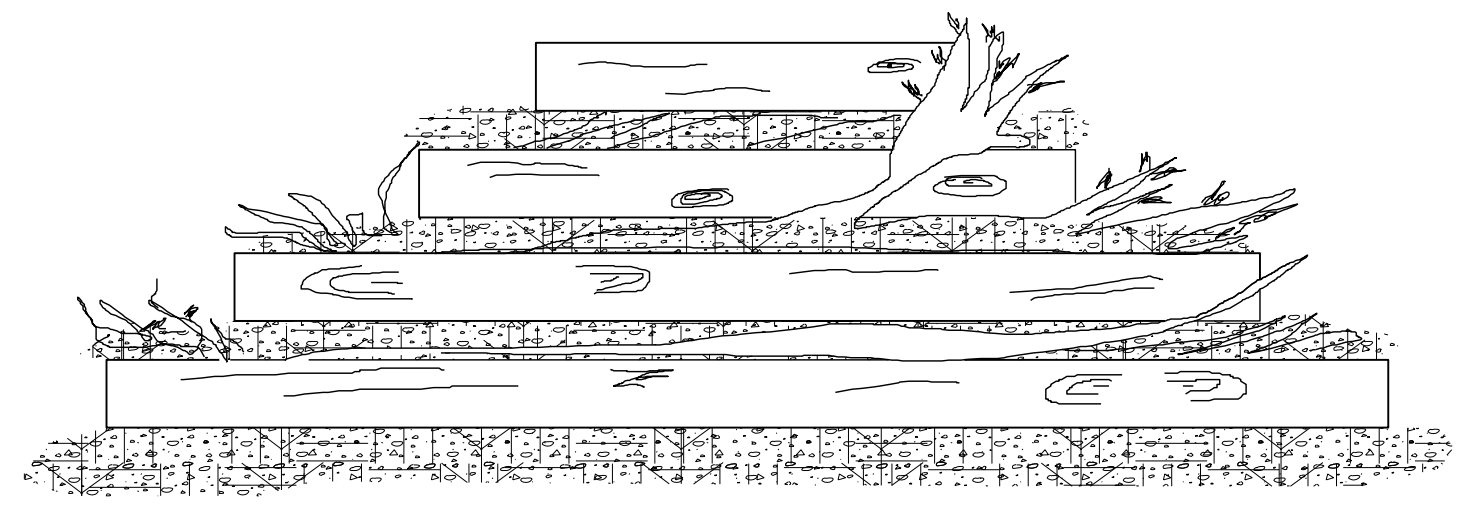

FRONT ELEVATION

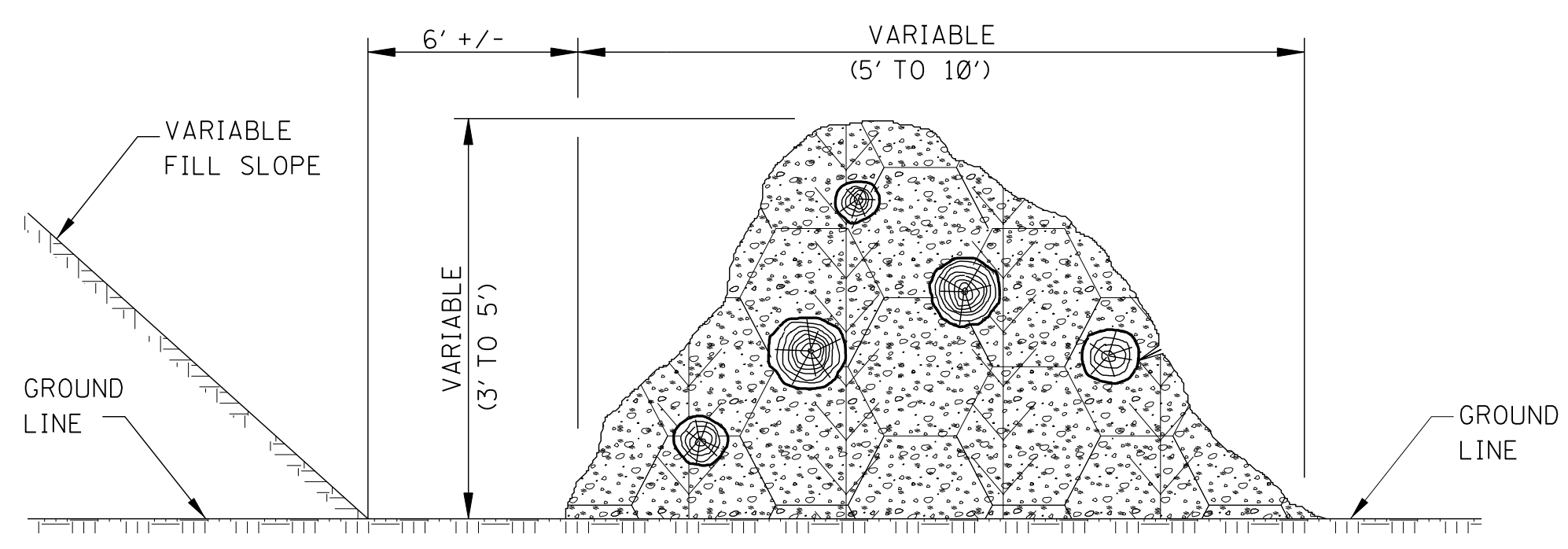

SIDE ELEVATION

TEMPORARY BRUSH BARRIER

NOTES:

- BRUSH BARRIER MAY BE USED WHERE NATURAL GROUND IS LEVEL OR SLOPING AWAY FROM PROJECT.
- PLACE BRUSH, LOG AND TREE LAPS APPROXIMATELY PARALLEL TO TOE OF FILL SLOPE WITH SOME OF THE HEAVIER MATERIALS BEING PLACED ON TO TO PROPERLY SECURE THE BARRIER AS DETAILED AT LOCATIONS SHOWN ON PLANS OR AS DIRECTED OR PERMITTED BY THE ENGINEER.
- TO ALLOW WATER TO SEEP THROUGH BRUSH BARRIER, INTERMINGLE THE BRUSH, LOG AND TREE LAPS SO AS NOT TO FORM A SOLID DAM.
- THE BRUSH BARRIER MAY BE CHOKED WITH FILTER FABRIC. THE COST OF FABRIC TO BE INCLUDED IN OTHER ITEMS BID.
- TEMPORARY BRUSH BARRIER WILL NOT BE MEASURED FOR SEPARATE PAYMENT.

NOTE: ANCHOR AND INSTALL SILT FENCE PER DETAILS SHOWN ON WK. NO. ECD-3

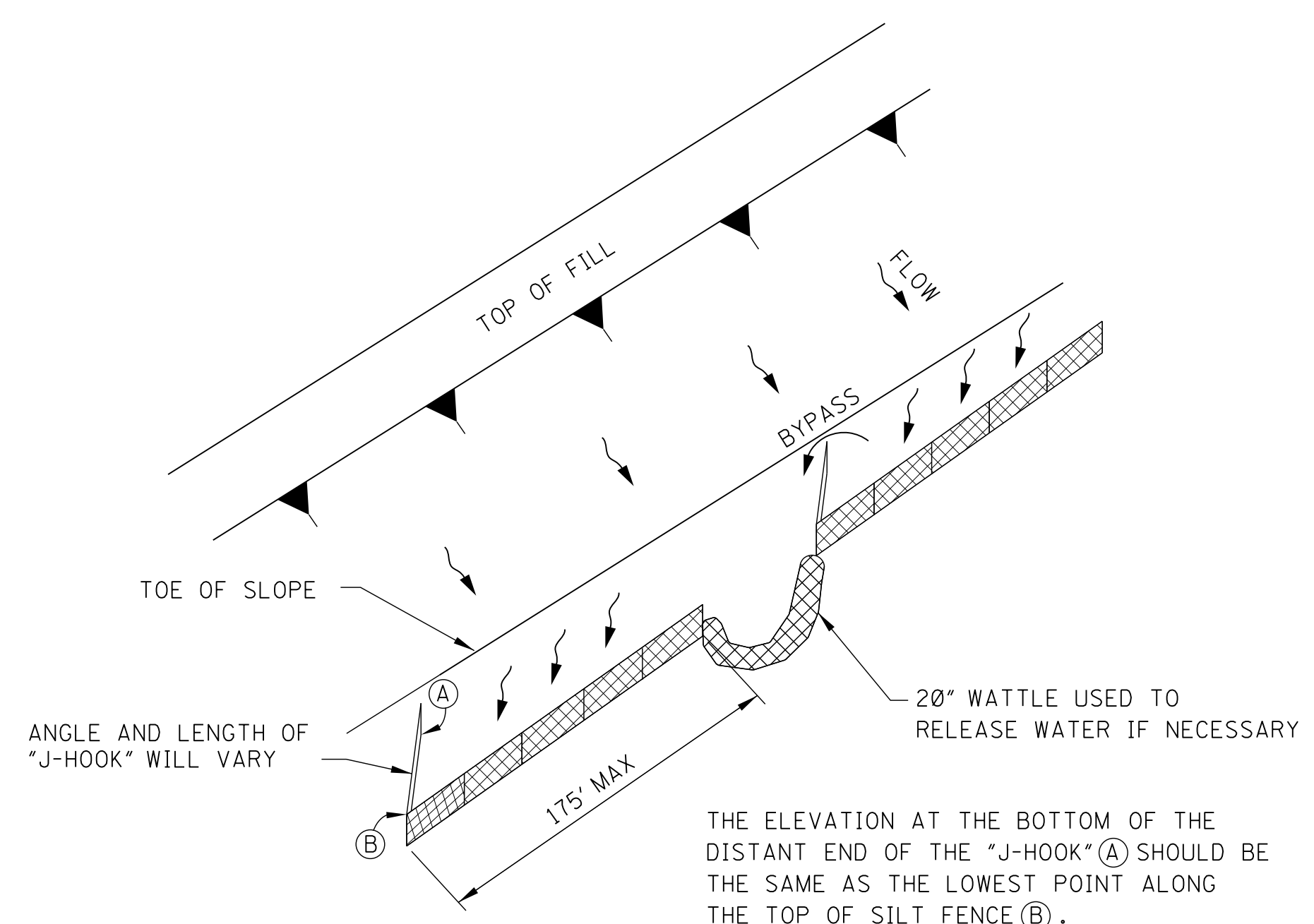

"J-HOOK" SILT FENCE APPLICATION

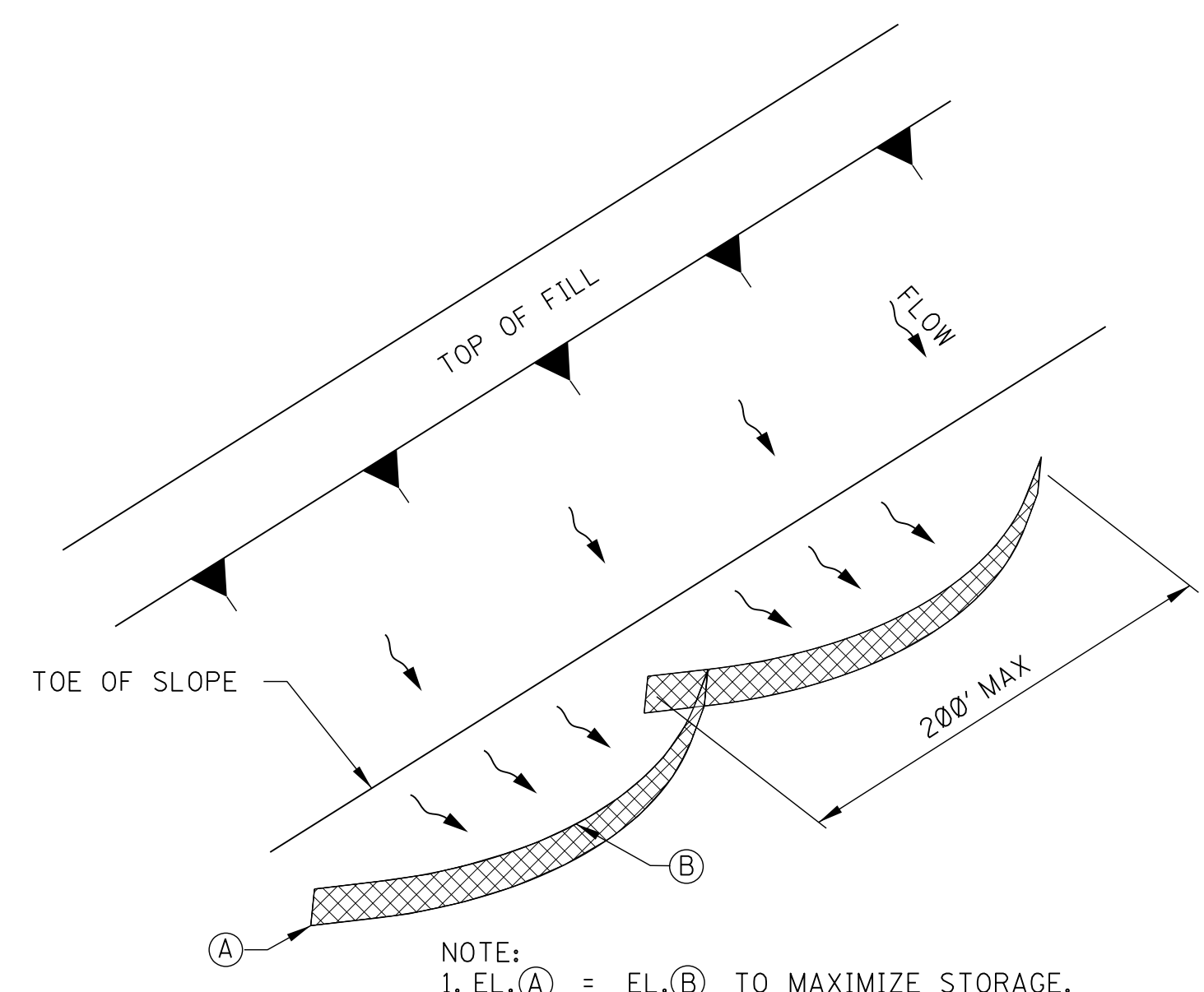

"SMILE-CONFIGURATION" SILT FENCE APPLICATION

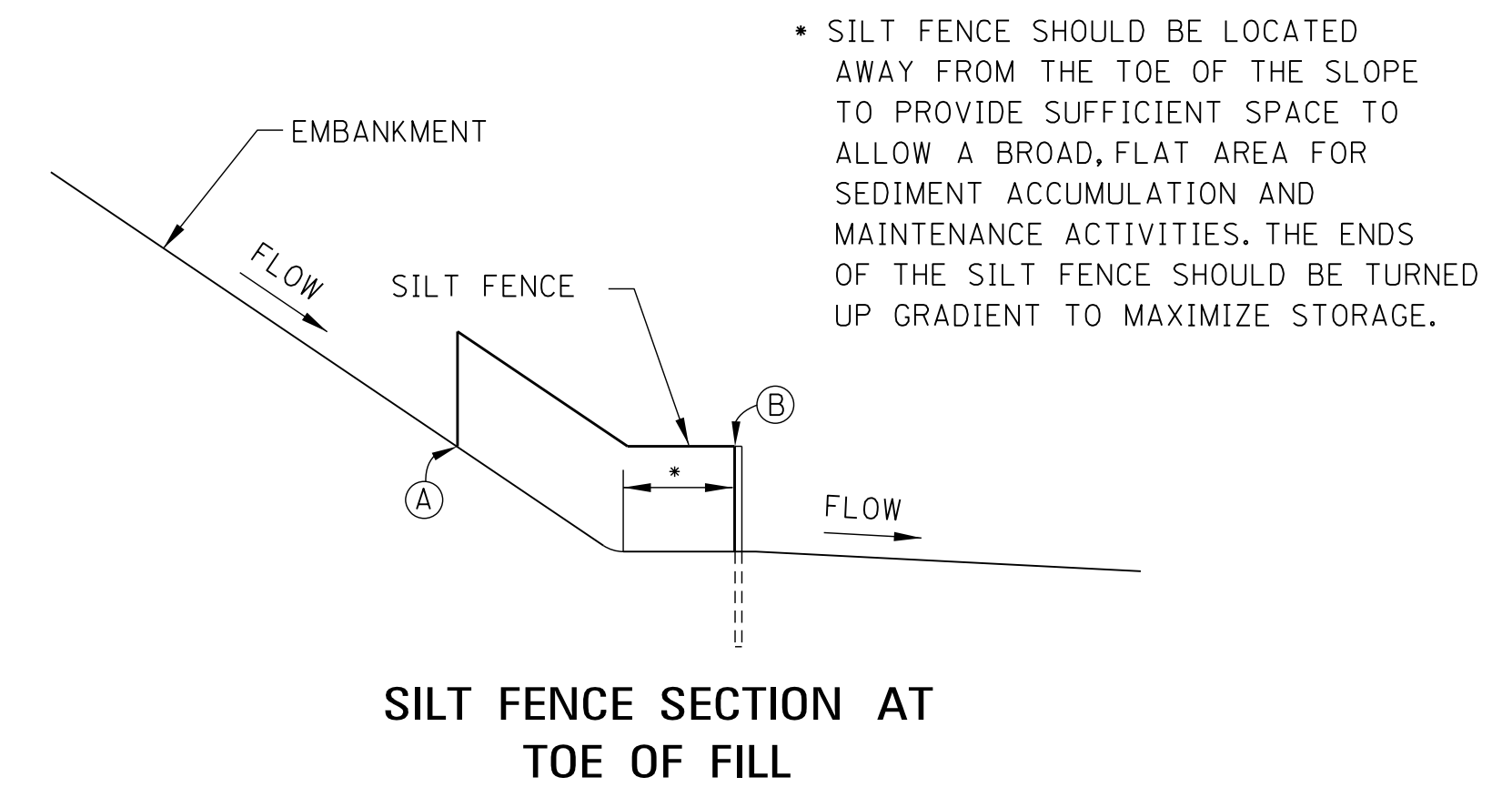

SILT FENCE SECTION AT TOE OF FILL

BY		MISSISSIPPI DEPARTMENT OF TRANSPORTATION	
REVISION		ROADWAY DESIGN DIVISION	
DATE		STANDARD PLAN	
		DETAILS OF SEDIMENT BARRIER APPLICATIONS	
			
		WORKING NUMBER ECD-2	
		SHEET NUMBER 6102	
		ISSUE DATE: AUGUST 01, 2017	

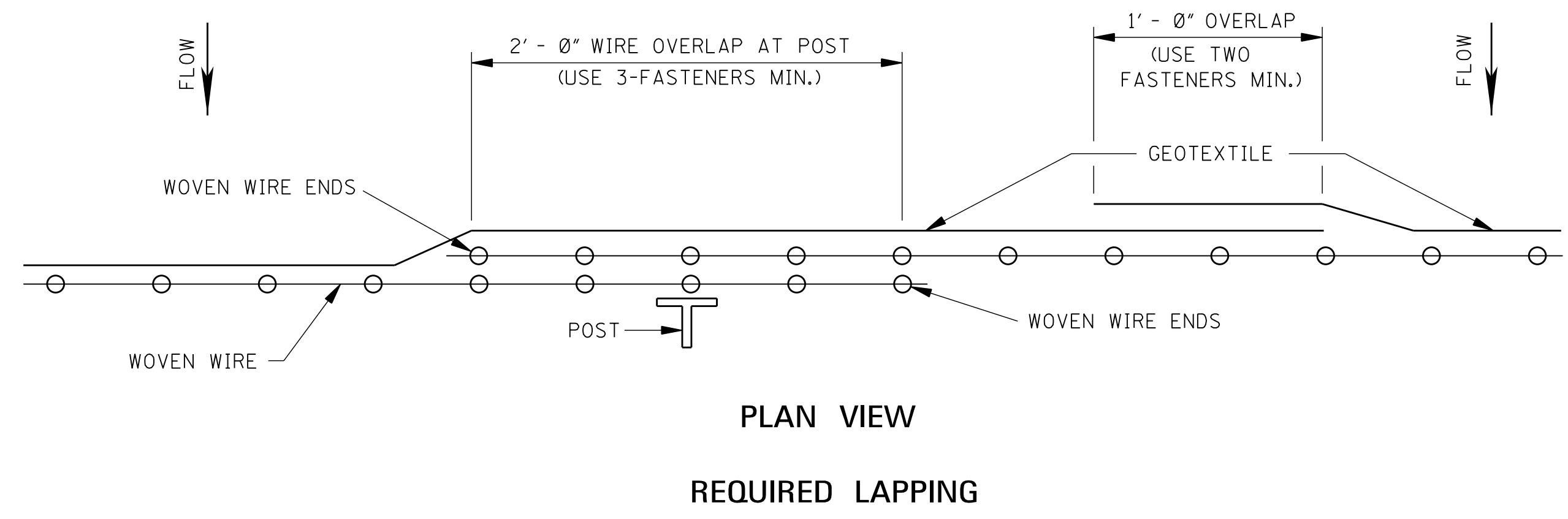
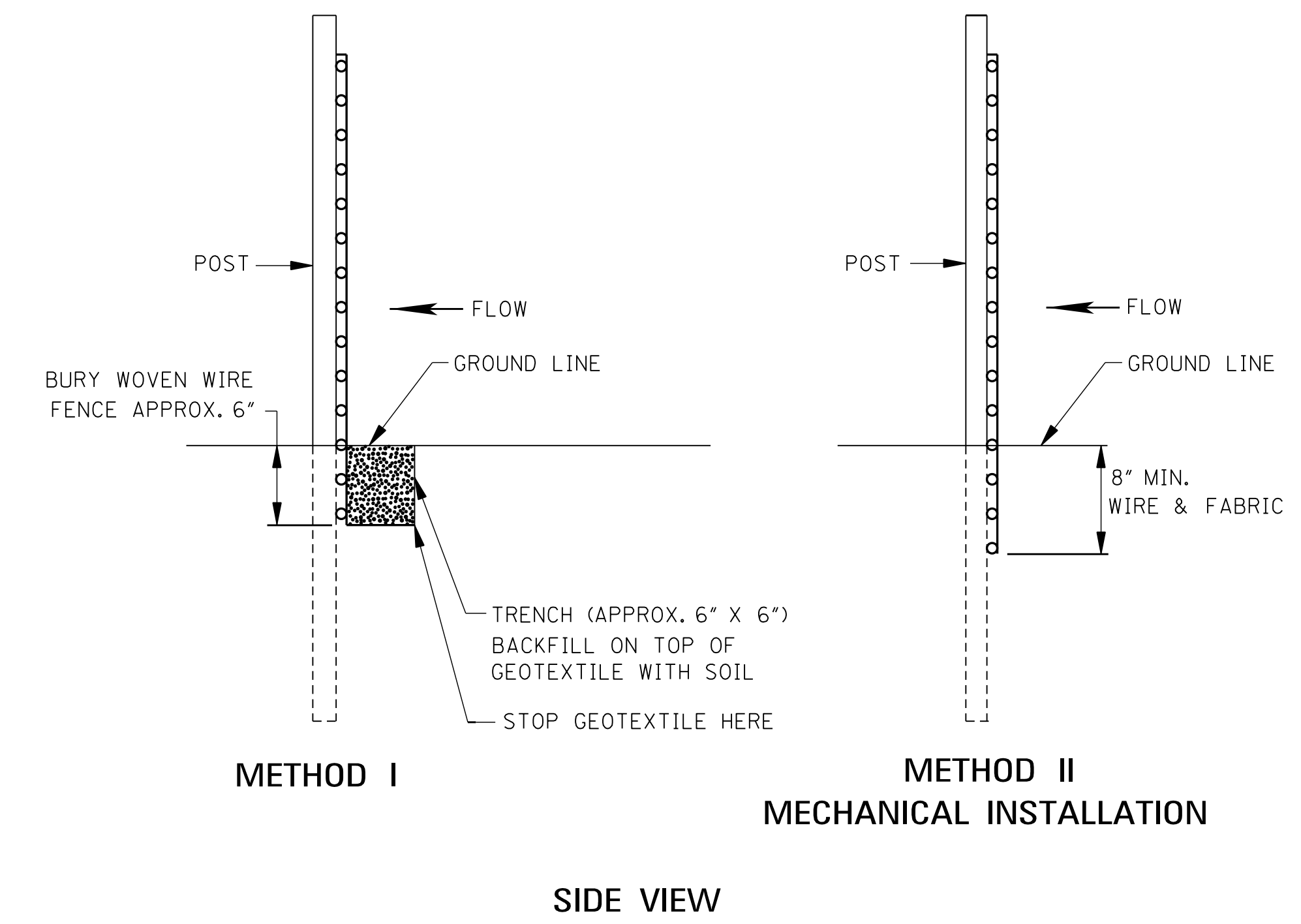
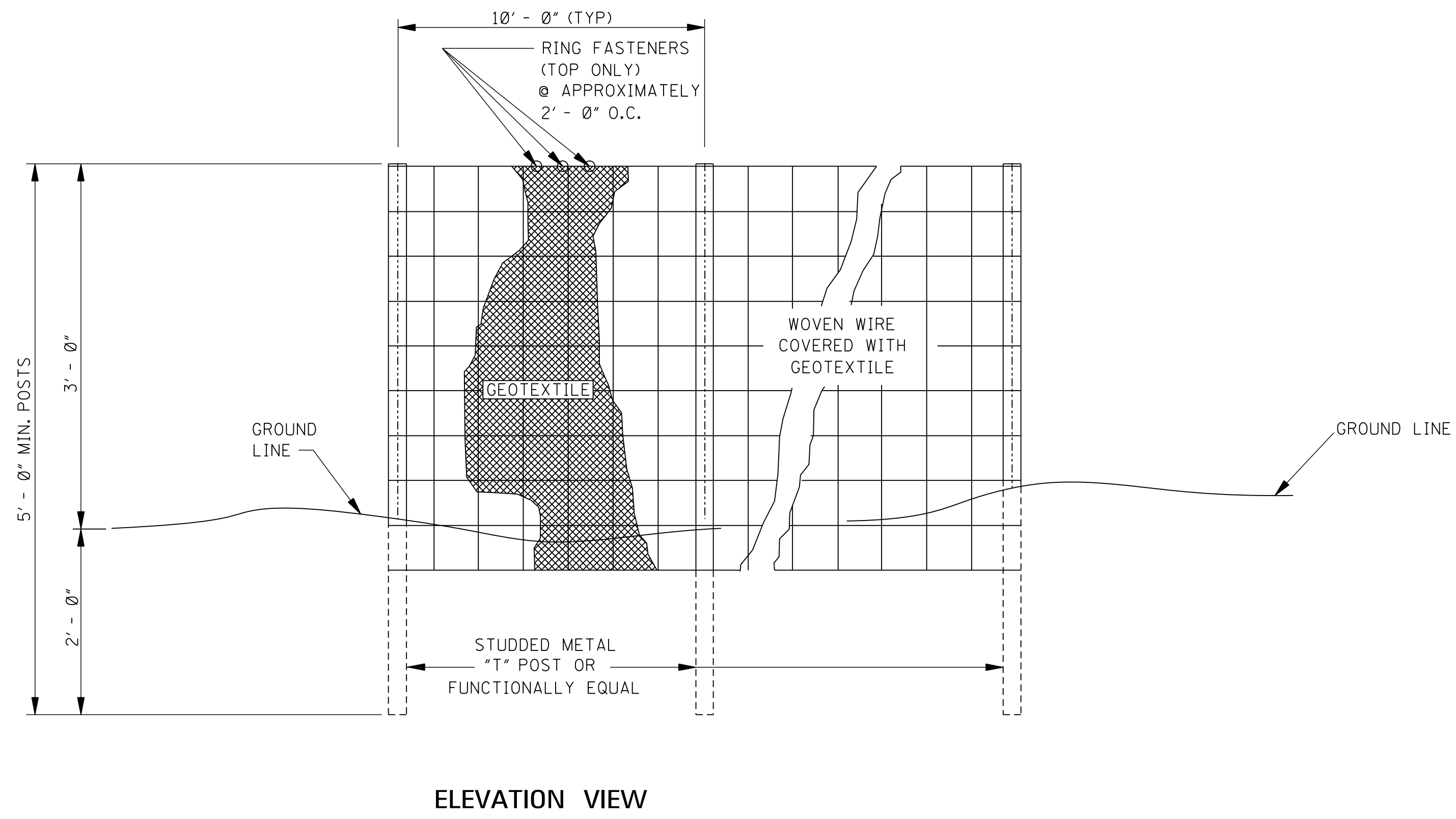

GENERAL NOTES:

- SILT FENCES SHOULD BE USED IN AREAS WHERE FLOW IS NOT SEVERE.
- SILT FENCES ARE TEMPORARY SEDIMENT CONTROL ITEMS THAT SHOULD BE ERECTED OPPOSITE ERODIBLE AREAS SUCH AS NEWLY GRADED FILL SLOPES AND ADJACENT TO STEAMS AND CHANNELS.
- SILT FENCE SHOULD BE PLACED WELL INSIDE RIGHT-OF-WAY AND ALONG EDGE OF CLEARING LIMITS. THIS WILL ALLOW ROOM FOR BACK-UP FENCE IF FIRST FENCE BECOMES FULL.
- WHENEVER POSSIBLE SILT FENCE SHOULD BE CONSTRUCTED ACROSS A LEVEL AREA IN THE SHAPE OF A SMILE. THIS AIDS IN PONDING OF RUNOFF AN FACILITATES SEDIMENTATION.
- THE CONTRACTOR MAY ELECT TO USE EITHER METHOD I OR METHOD II. COST TO BE LINEAR FEET OF SILT FENCE.
- METHOD II INSTALLATION SHALL BE ACCOMPLISHED USING AN IMPLEMENT THAT IS MANUFACTURED FOR THE APPLICATION AND PROVIDES A CONFIGURATION MEETING THE REQUIREMENTS OF DETAIL.
- WIRE SHALL BE A MINIMUM OF 32" IN WIDTH AND SHALL HAVE A MINIMUM OF 6 LINE WIRES WITH 12" STAY SPACING.
- GEOTEXTILE FABRIC MEETING THE TYPE II MATERIAL REQUIREMENTS AND INSTALLED ACCORDING TO SPECIFICATION MAY BE USED WITHOUT WIRE FENCE.

BY		MISSISSIPPI DEPARTMENT OF TRANSPORTATION ROADWAY DESIGN DIVISION STANDARD PLAN	
REVISION		<p>DETAILS OF SILT FENCE INSTALLATION</p> 	
DATE			
ISSUE DATE: AUGUST 01, 2017		WORKING NUMBER ECD-3	SHEET NUMBER 6103

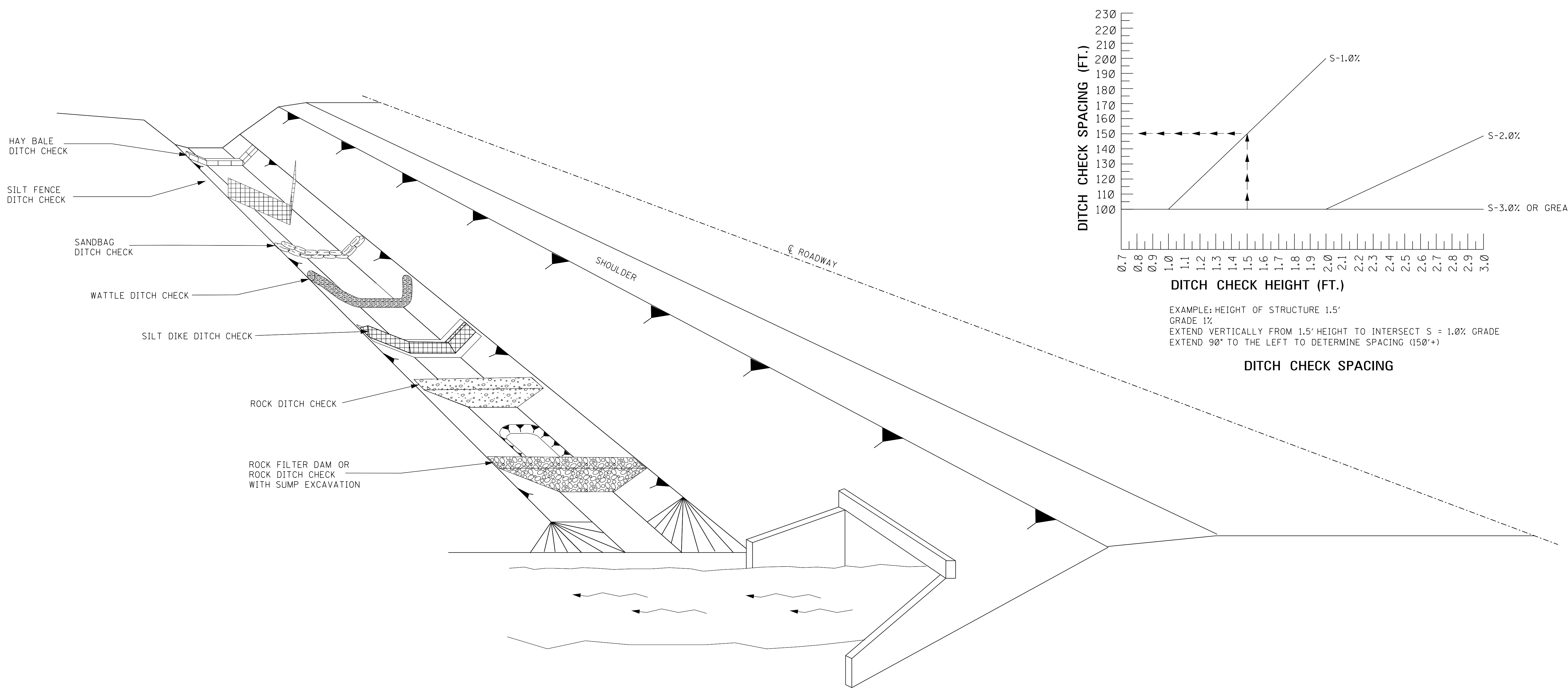

EXAMPLE: HEIGHT OF STRUCTURE 1.5'
 GRADE 1%
 EXTEND VERTICALLY FROM 1.5' HEIGHT TO INTERSECT S = 1.0% GRADE
 EXTEND 90° TO THE LEFT TO DETERMINE SPACING (150'+)

GENERAL NOTES:

1. THE DITCH CHECK PERSPECTIVE ILLUSTRATES A TOOL BOX OF TEMPORARY PRACTICES THAT MAY BE USED. DITCH CHECKS ARE INSTALLED TO CONTROL RUNOFF VELOCITY AND THUS REDUCE EROSION AND PROVIDE FOR TRAPPING OF SEDIMENTS.
2. SELECTION OF THE APPROPRIATE DITCH CHECK SHOULD BE A FUNCTION OF CONSTRUCTION PHASE, DRAINAGE AREA, DITCH GRADIENT, SOIL TYPE, ECONOMY AND SAFETY.
3. DITCH CHECKS CAN BE REMOVED FOR MAINTENANCE AND/OR REPLACEMENT BUT MUST REMAIN IN PLACE UNTIL UPSLOPE AREAS HAVE BEEN PERMANENTLY STABILIZED. MAINTENANCE INCLUDES REMOVAL OF SEDIMENT BEGINNING WHEN SEDIMENT ACCUMULATION REACHES 1/3 THE CAPACITY OR HEIGHT OF THE STRUCTURE AND NEVER ALLOWING FOR SEDIMENT TO ACCUMULATE MORE THAN 1/2 THE VOLUME OR HEIGHT OF THE DITCH CHECK STRUCTURE.
4. HAY BALES SHOULD BE USED TO INTERCEPT LOW VOLUME FLOWS IN LOW TO MODERATE GRADIENT DITCHES.
5. SILT FENCE DITCH CHECKS SHOULD BE USED WHERE IT HAS BEEN DETERMINED THAT HAY BALE CHECKS ARE INADEQUATE. SILT FENCE DITCH CHECKS SHOULD BE USED TO INTERCEPT LOW VOLUME FLOWS IN LOW TO MODERATE GRADIENT DITCHES.
6. SANDBAG DITCH CHECKS SHOULD BE USED FOR VELOCITY REDUCTION AND MINIMAL SEDIMENT TRAPPING IN CONCRETE PAVED DITCHES OR IN DITCHES THAT HAVE ROCK BOTTOMS.
7. WATTLE DITCH CHECKS CAN BE USED FOR VELOCITY REDUCTION AND CONTROL OF SEDIMENT TRANSPORT UNDER LOW TO MEDIUM FLOW CONDITIONS.
8. SILT DIKES CAN BE USED IN DITCHES WITH CONCENTRATED FLOWS WITHIN THE CLEAR ZONE WHERE RIPRAP CAN NOT BE USED, AS CONSTRUCTION PROGRESSES.
9. ROCK DITCH CHECKS WITH SUMP EXCAVATION CAN BE PLACED IN DITCHES TO ASSURE ON-SITE SEDIMENT TRAPPING REQUIREMENTS ARE MET. DITCH CHECK WITH SUMP EXCAVATION IS USED WHEN DITCHES RECEIVE DRAINAGE FROM CUT OR FILL SLOPES OR OTHER CRITICAL AREAS WHERE SOIL EROSION IS EXPECTED. DRAINAGE AREA FOR A TEMPORARY SEDIMENT TRAP SHOULD BE LIMITED TO 3 ACRES. THEY CAN BE USED IN SERIES TO INCREASE ON-SITE SEDIMENT TRAPPING EFFICIENCY.
10. DITCH CHECKS, IN NO CASE, SHALL BE PLACED IN LIVE STREAMS.
11. CONFIGURATION AND SPACING MAY BE ADJUSTED IF APPROVED BY THE ENGINEER TO ACCOMMODATE TRAVELWAY SAFETY, WATER FLOW, OR SOIL AND INSTALLATION CHALLENGES.

MISSISSIPPI DEPARTMENT OF TRANSPORTATION ROADWAY DESIGN DIVISION STANDARD PLAN	
DITCH CHECK STRUCTURES, TYPICAL APPLICATIONS AND DETAILS	
DATE	ISSUE DATE: AUGUST 01, 2017
BY	
REVISION	
WORKING NUMBER	ECD-4
SHEET NUMBER	6104

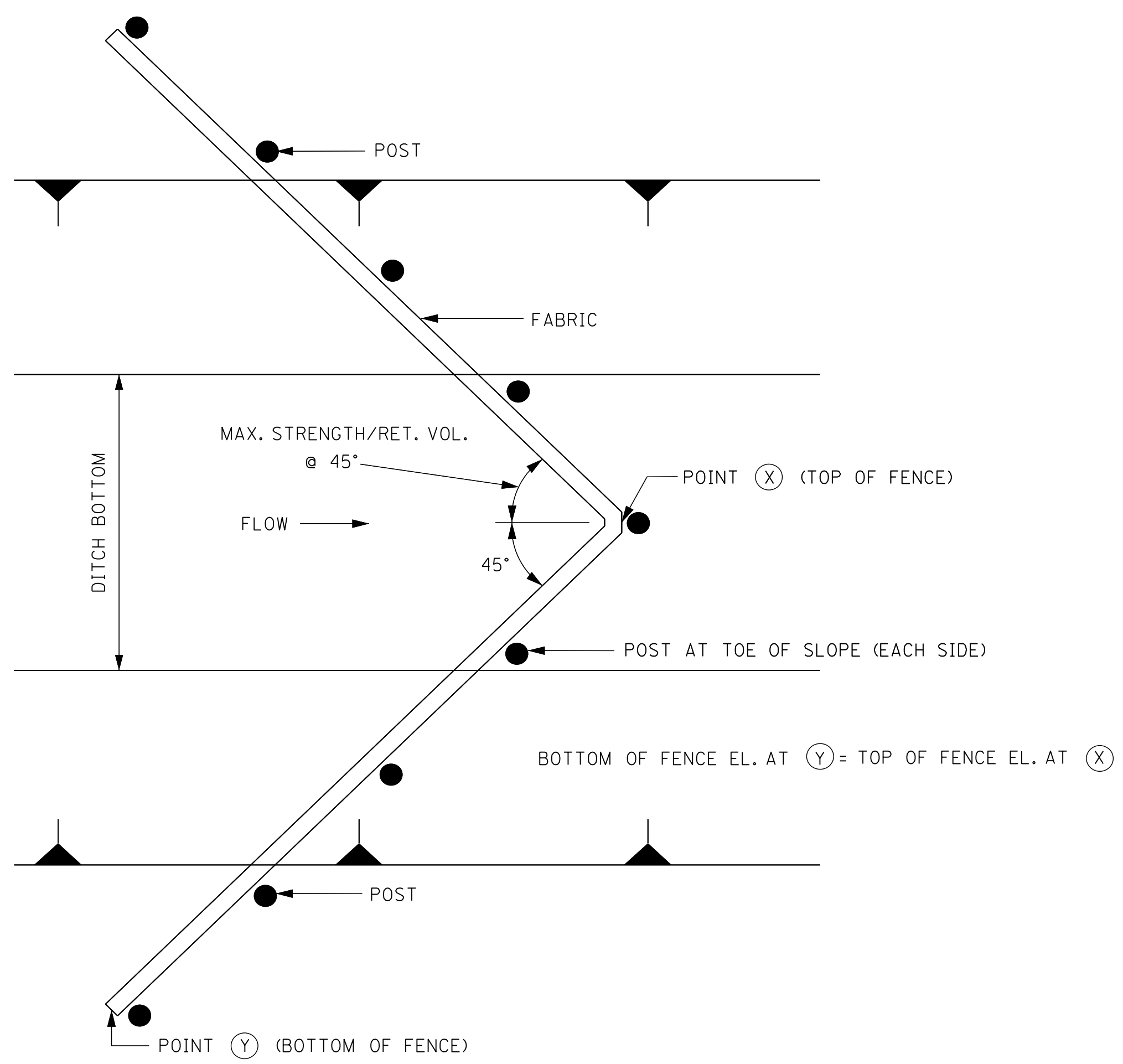

PLAN VIEW

- NOTES:
1. ANCHOR AND INSTALL PER DETAILS FOR SILT FENCE SPACING GUIDELINES ON WK. NO. ECD-4.
 2. A "W" SHAPE MAY BE USED FOR WIDER DITCHES.

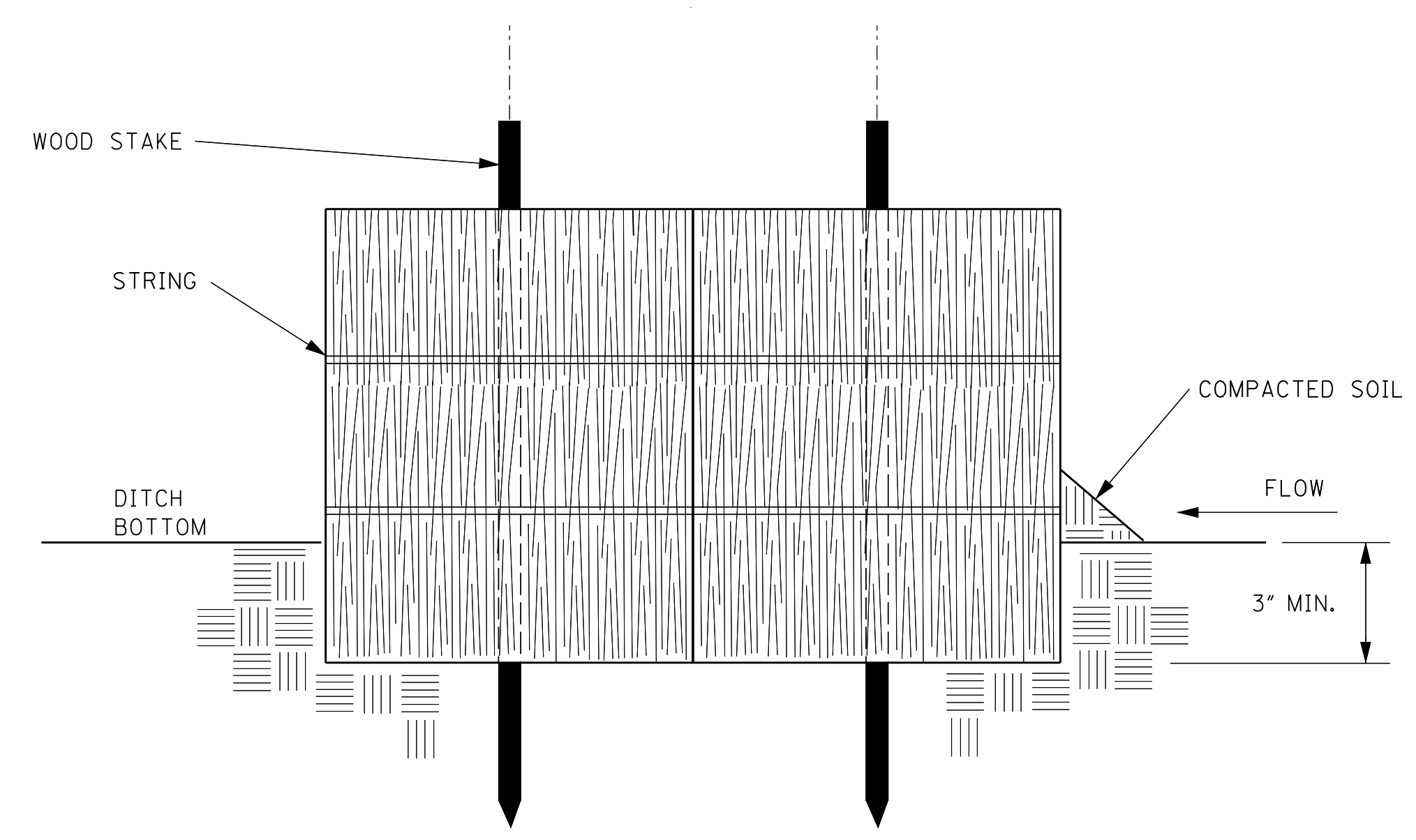

SECTION A-A

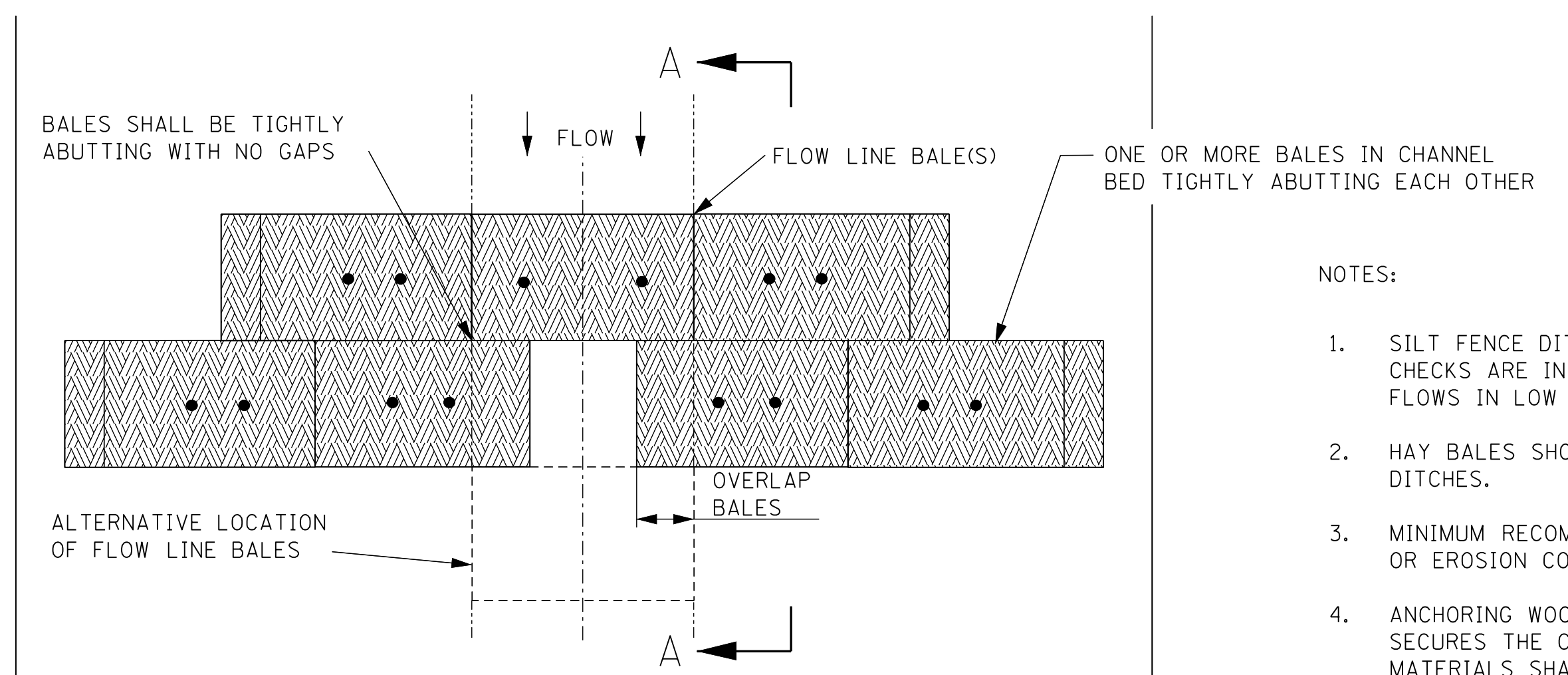

**PLAN VIEW
TRAPEZOIDAL DITCH**

NOTES:

1. SILT FENCE DITCH CHECKS SHOULD BE USED WHERE IT HAS BEEN DETERMINED THAT HAY BALE CHECKS ARE INADEQUATE. SILT FENCE DITCH CHECKS SHOULD BE USED TO INTERCEPT LOW VOLUME FLOWS IN LOW TO MODERATE GRADIENT DITCHES.
2. HAY BALES SHOULD BE USED TO INTERCEPT LOW VOLUME FLOWS IN LOW TO MODERATE GRADIENT DITCHES.
3. MINIMUM RECOMMENDED CHECK SPACING IS 100 FEET UNLESS SHOWN OTHERWISE ON THE PLANS OR EROSION CONTROL PLAN APPROVED BY THE ENGINEER. SEE SPACING GUIDANCE ON WK. NO. ECD-4.
4. ANCHORING WOOD STAKES SHALL BE SIZED, SPACED, AND BE OF A MATERIAL THAT EFFECTIVELY SECURES THE CHECK. A MINIMUM OF TWO STAKES PER BALE IS REQUIRED. ALL NON-DEGRADABLE MATERIALS SHALL BE REMOVED WHEN NO LONGER NEEDED.
5. BALES SHALL BE EMBEDDED IN THE SOIL A MINIMUM OF 3 INCHES.
6. BALES SHALL BE PLACED IN A ROW WITH ENDS TIGHTLY ABUTTING THE ADJACENT BALES. THE BALES SHALL BE PLACED WITH BINDINGS PARALLEL TO THE GROUND.
7. SOIL IS COMPACTED ALONG THE BASE OF THE UPSTREAM FACE TO PREVENT PIPING.
8. MULTIPLE ADJACENT ROWS OF BALES ARE REQUIRED AS SHOWN.

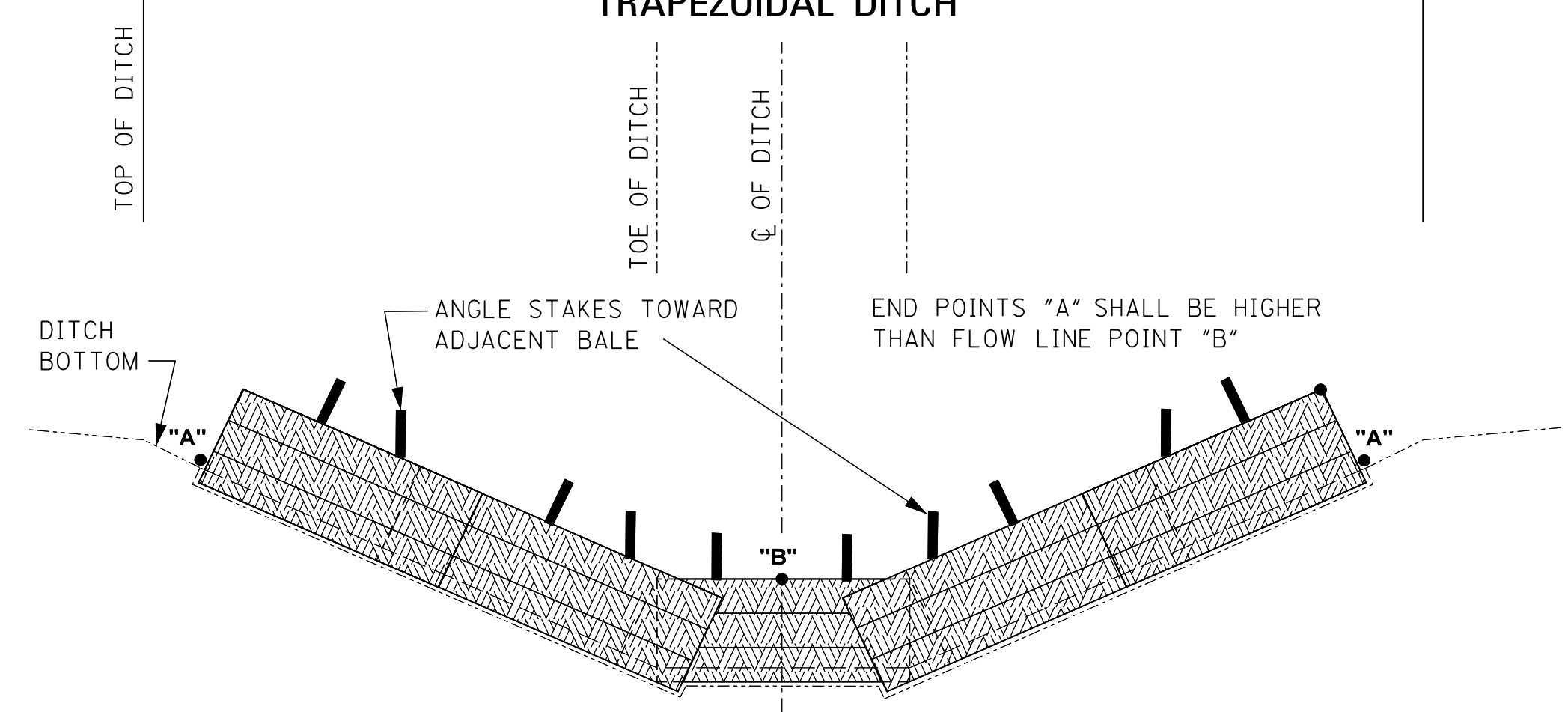

**PROFILE VIEW
TRAPEZOIDAL DITCH**

BY	MISSISSIPPI DEPARTMENT OF TRANSPORTATION ROADWAY DESIGN DIVISION STANDARD PLAN
REVISION	TEMPORARY EROSION, SEDIMENT, AND WATER POLLUTION CONTROL MEASURES (SILT FENCE AND HAY BALE DITCH CHECKS)
DATE	ISSUE DATE: AUGUST 01, 2017



WORKING NUMBER
ECD-5
SHEET NUMBER
6105

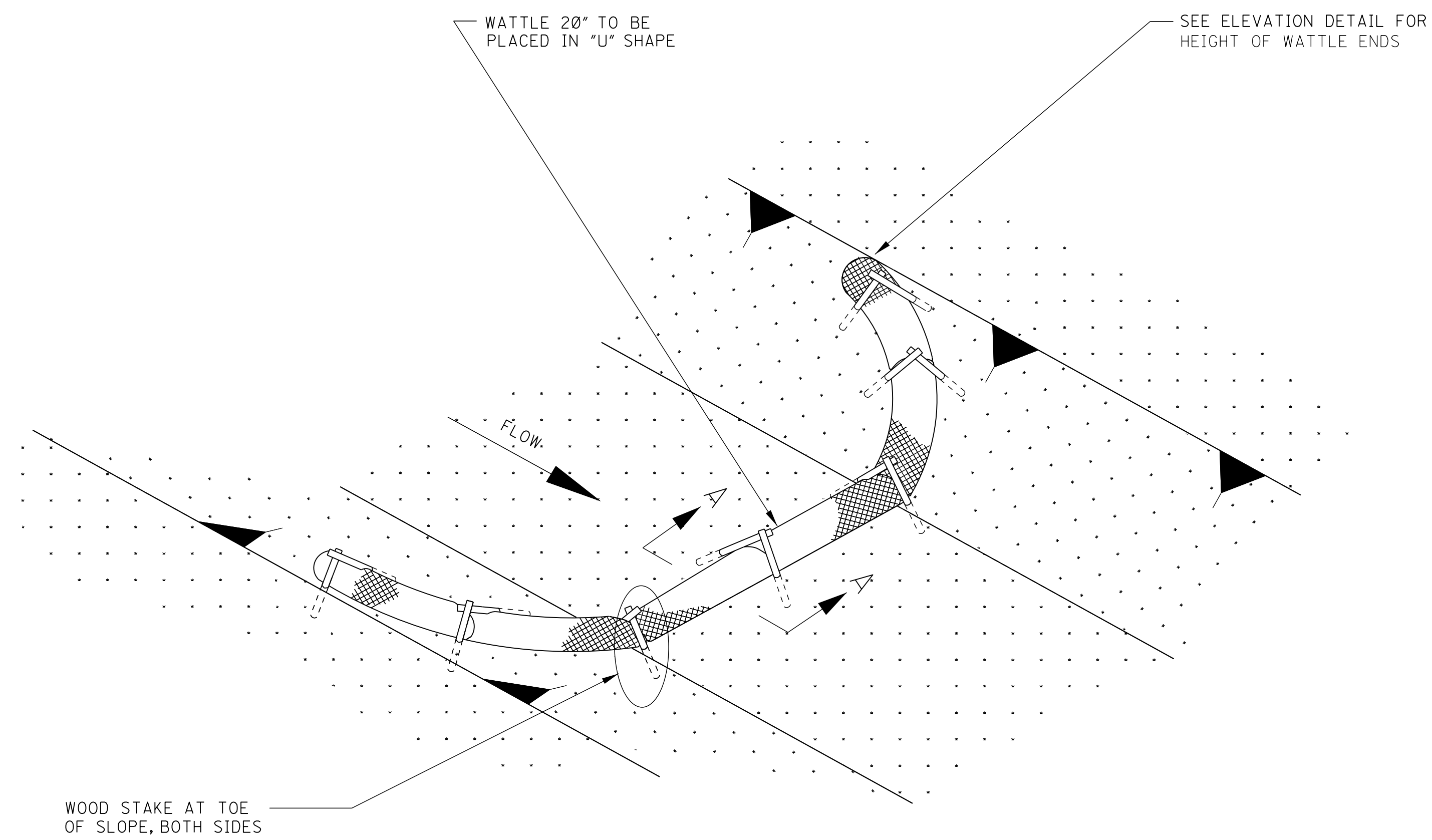

DETAIL (DITCH CHECK)

WOOD STAKE AT TOE OF SLOPE, BOTH SIDES

SEE ELEVATION DETAIL FOR HEIGHT OF WATTLE ENDS

WATTLE 20" TO BE PLACED IN "U" SHAPE

FLOW

FLOW

FLOW

FLOW

FLOW

FLOW

FLOW

FLOW

FLOW

FLOW

FLOW

FLOW

FLOW

NOTE: END POINTS "A" SHALL BE HIGHER THAN FLOWLINE POINT "B".

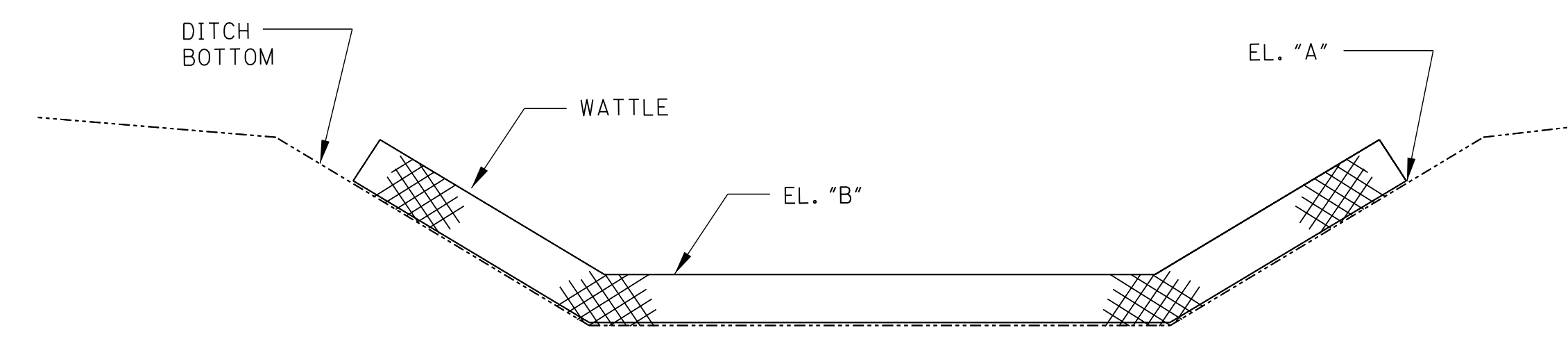

ELEVATION DETAIL

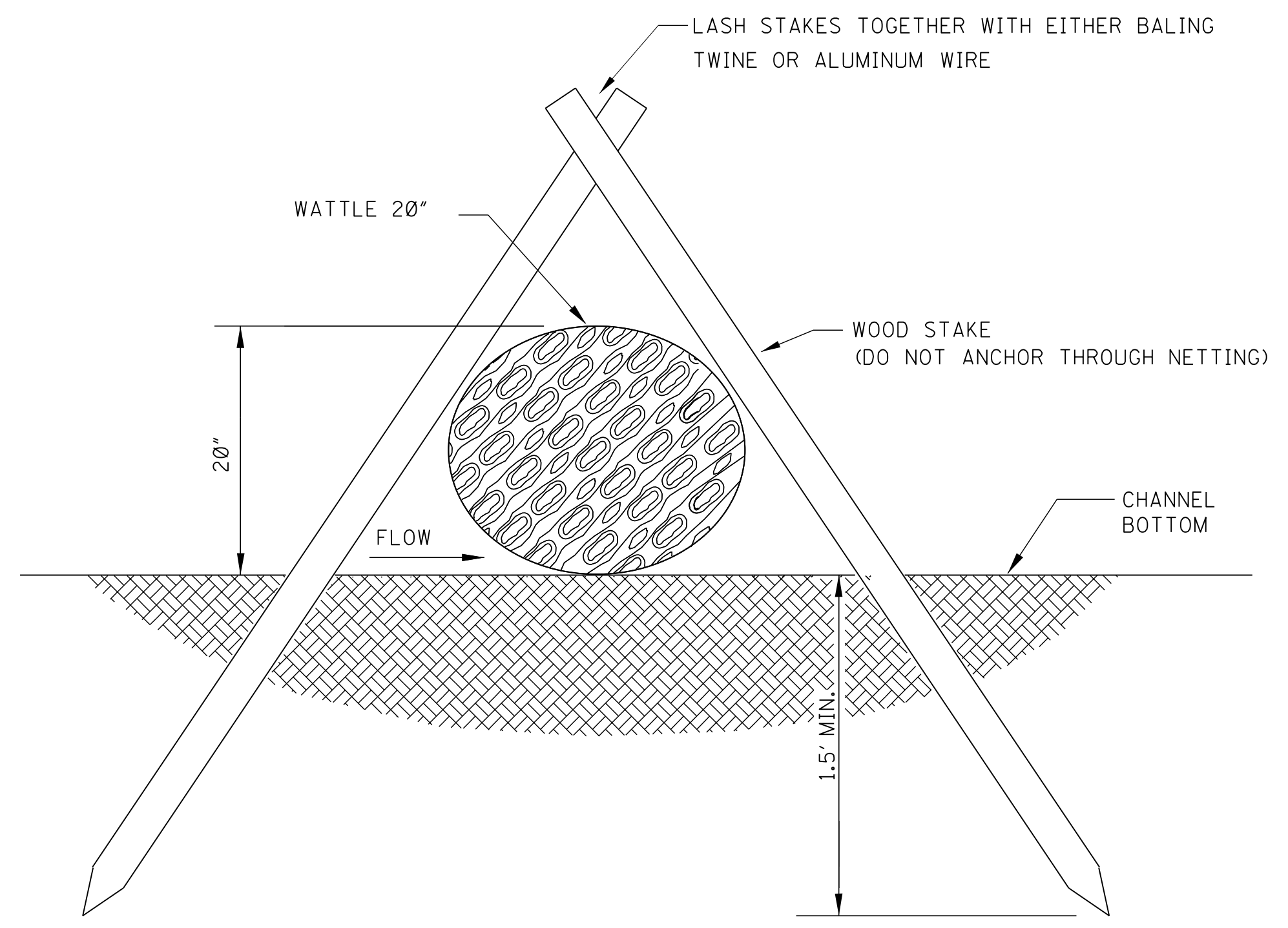

SECTION A-A

NOTES:

1. WATTLE DITCH CHECKS CAN BE USED FOR VELOCITY REDUCTION AND CONTROL OF SEDIMENT TRANSPORT UNDER LOW TO MEDIUM FLOW CONDITIONS.
2. THE PLACEMENT INTERVAL BETWEEN WATTLE DITCH CHECK SHALL BE 100' UNLESS SHOWN OTHERWISE ON THE PLANS OR EROSION CONTROL PLAN APPROVED BY THE ENGINEER. SEE SPACING GUIDANCE ON WK. NO. ECD-4.
3. ANCHORING WOOD STAKES SHALL BE SIZED, SPACED, DRIVEN, AND BE OF A MATERIAL THAT EFFECTIVELY SECURES THE CHECK. STAKE SPACING SHALL BE A MAXIMUM OF THREE FEET. ALL NON-DEGRADABLE MATERIALS SHALL BE REMOVED WHEN NO LONGER NEEDED.
4. TRENCHING OF WATTLES MAY BE NECESSARY IF PIPING BECOMES EVIDENT.
5. WATTLES SHOULD NOT BE USED IN HARD BOTTOM CHANNELS.
6. IN THE EVENT WATTLES CANNOT BE SECURED IN PLACE USING WOOD STAKES, SAND BAGS MAY BE USED IN LIEU OF WOOD STAKES IN ORDER TO SECURE THE WATTLES IN PLACE. IF SANDS BAGS ARE USED IN THIS APPLICATION THEY WILL NOT BE A SEPARATE PAY ITEM.

BY		MISSISSIPPI DEPARTMENT OF TRANSPORTATION ROADWAY DESIGN DIVISION STANDARD PLAN	
REVISION		<p align="center">DETAILS OF EROSION CONTROL WATTLE DITCH CHECK</p> 	
DATE			
ISSUE DATE: AUGUST 01, 2017		WORKING NUMBER ECD-6	SHEET NUMBER 6106

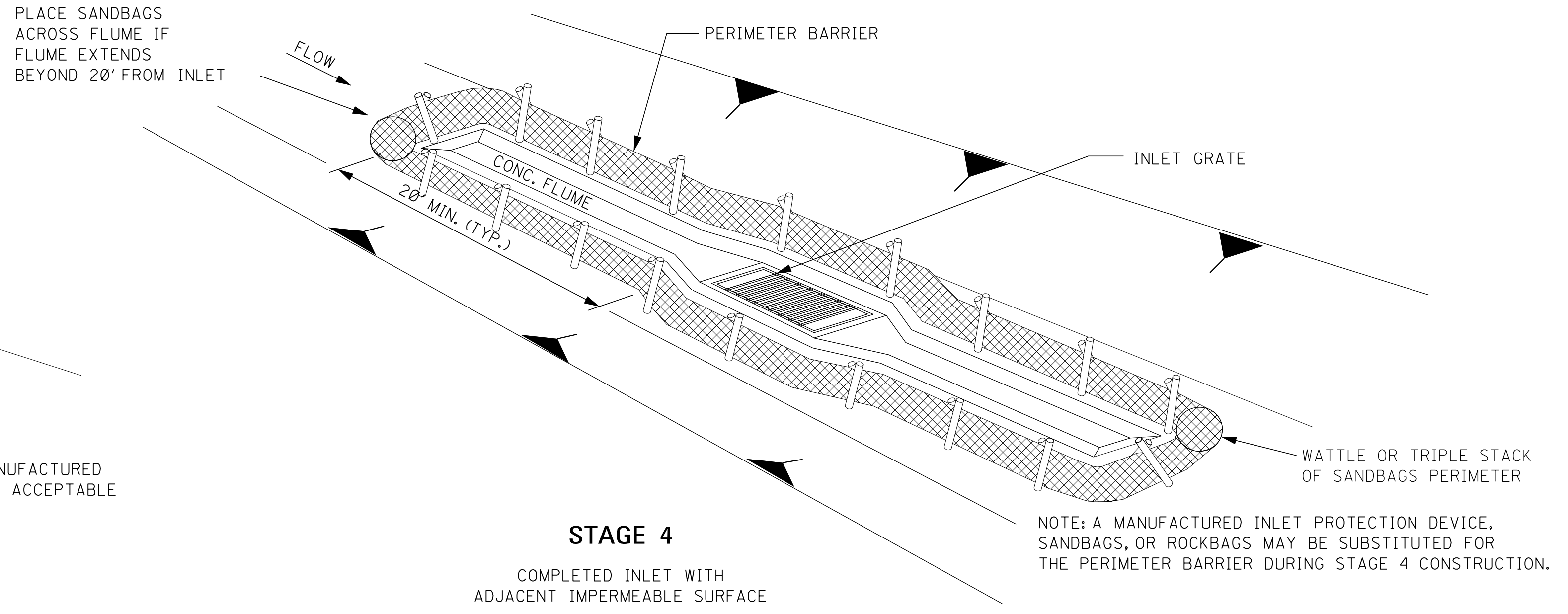
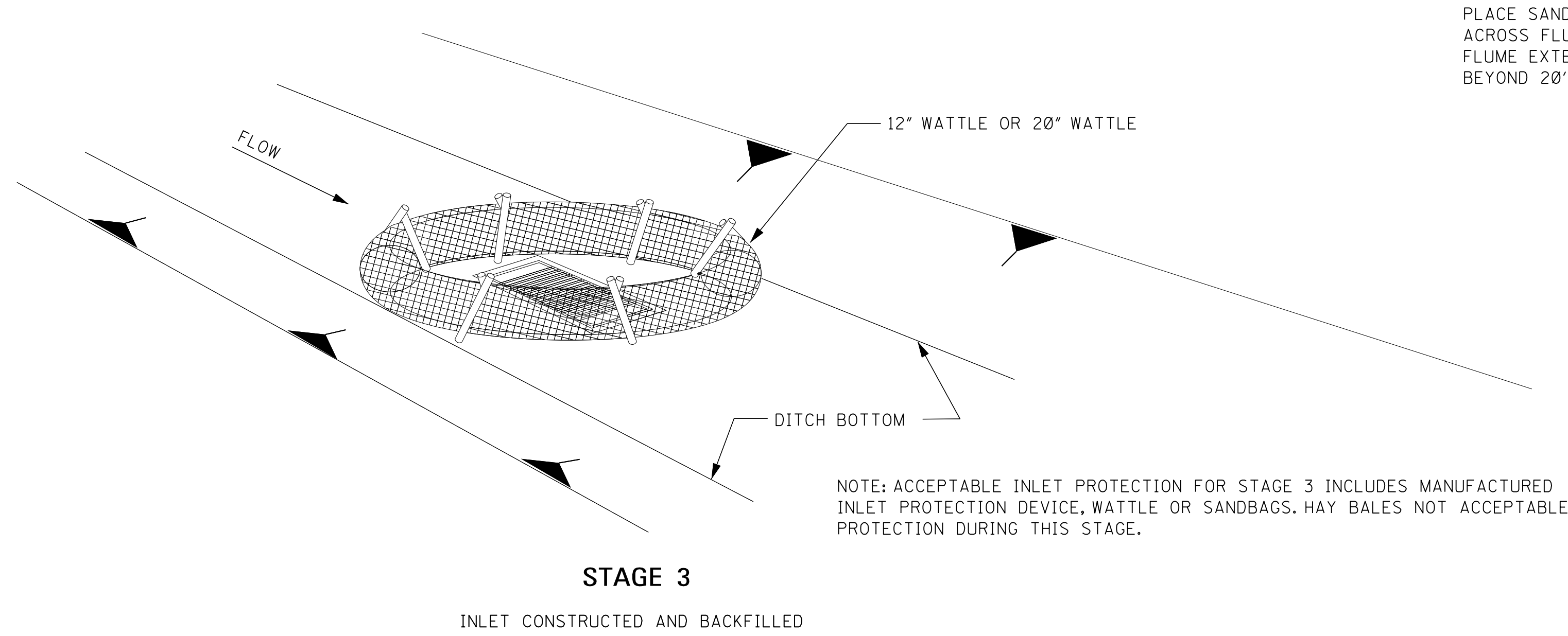
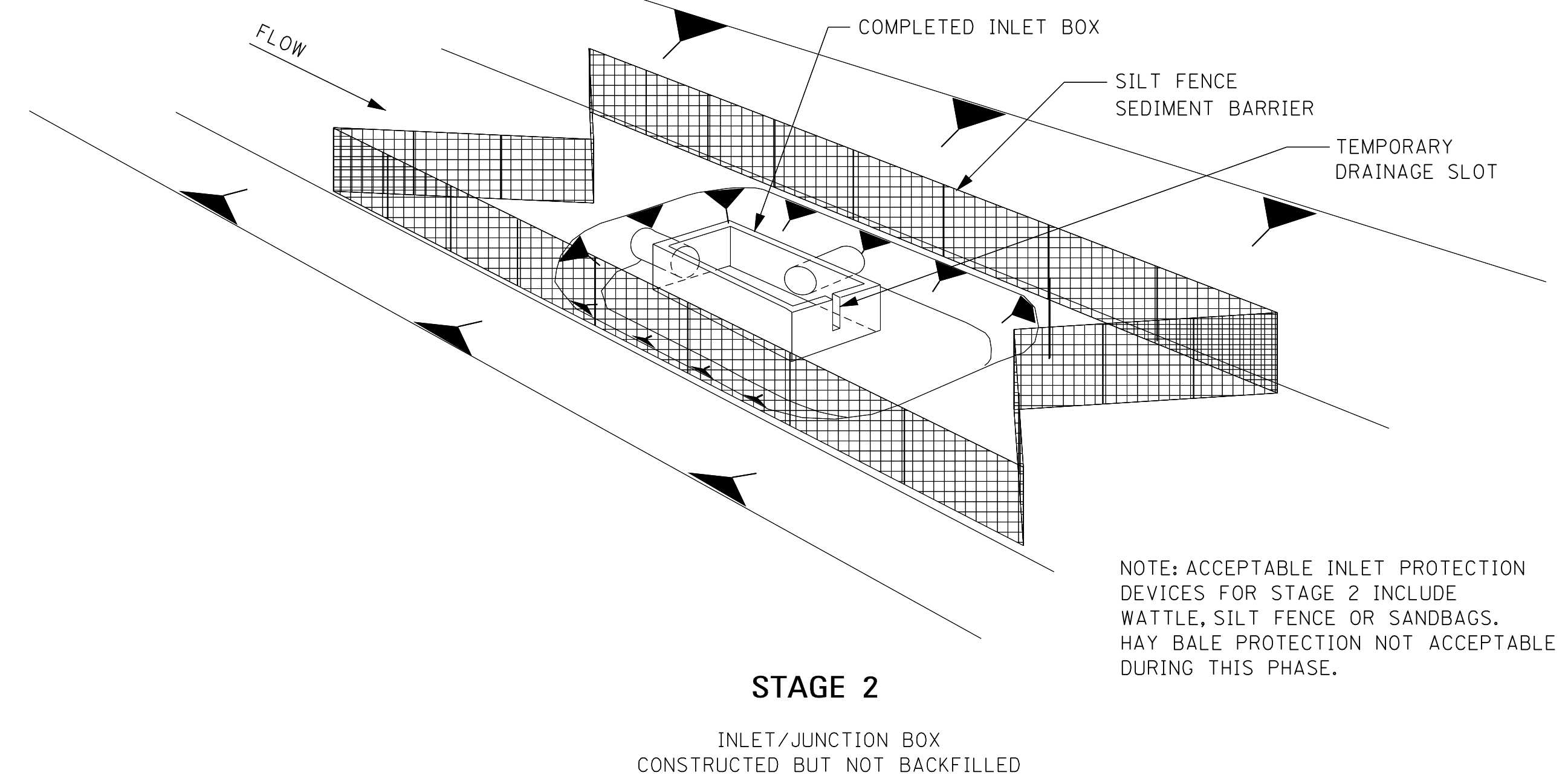
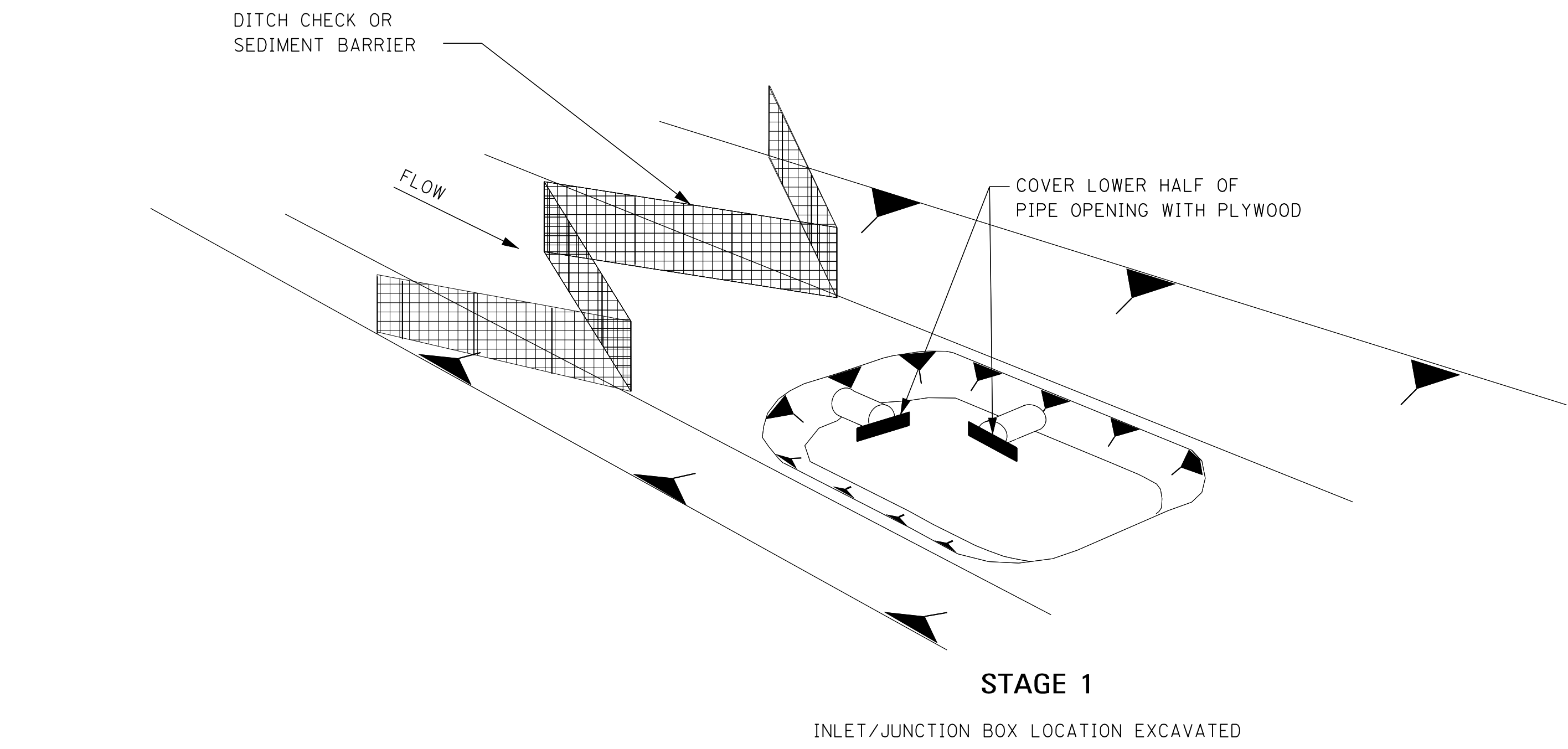

DITCH INLET CONSTRUCTION STAGES

NOTES:

1. DRAINAGE STRUCTURE BACKFILL SHOULD BE PLACED IN STAGE 1 IMMEDIATELY AFTER PIPE INSTALLATION. INLET CONSTRUCTION SHOULD COMMENCE AS SOON AS POSSIBLE AND BE CONTINUOUS THROUGH COMPLETION.
2. CONFIGURATIONS MAY BE ADJUSTED WITH APPROVAL OF THE ENGINEER FOR TRAVELWAY SAFETY, WATER FLOW, OR SOIL AND INSTALLATION CHALLENGES.
3. DURING STAGE 1 AND STAGE 2, SILT FENCE MAY BE REQUIRED UPSLOPE OF THE INLET EXCAVATION AS DIRECTED BY THE ENGINEER.
4. IF SILT FENCE IS INSTALLED AROUND THE INLET INSTALLATION IT SHOULD BE IN A CONFIGURATION THAT WILL ALLOW INLET CONSTRUCTION.
5. FOR INLET PROTECTION TO BE USED IN STAGES 1 AND 2 OF CONSTRUCTION, SEE WK. NO. ECD-12.

BY		MISSISSIPPI DEPARTMENT OF TRANSPORTATION ROADWAY DESIGN DIVISION STANDARD PLAN	
REVISION		<p>TYPICAL APPLICATIONS AND DETAILS FOR INLET CONSTRUCTION</p> <p>MDOT MISSISSIPPI DEPARTMENT OF TRANSPORTATION</p>	
DATE			
ISSUE DATE:		AUGUST 01, 2017	
WORKING NUMBER		ECD-11	
SHEET NUMBER		6111	

NOTE: SILT FENCE OR SANDBAGS MAY ALSO BE USED FOR THIS APPLICATION.
HAY BALES NOT ACCEPTABLE DURING THIS STAGE.

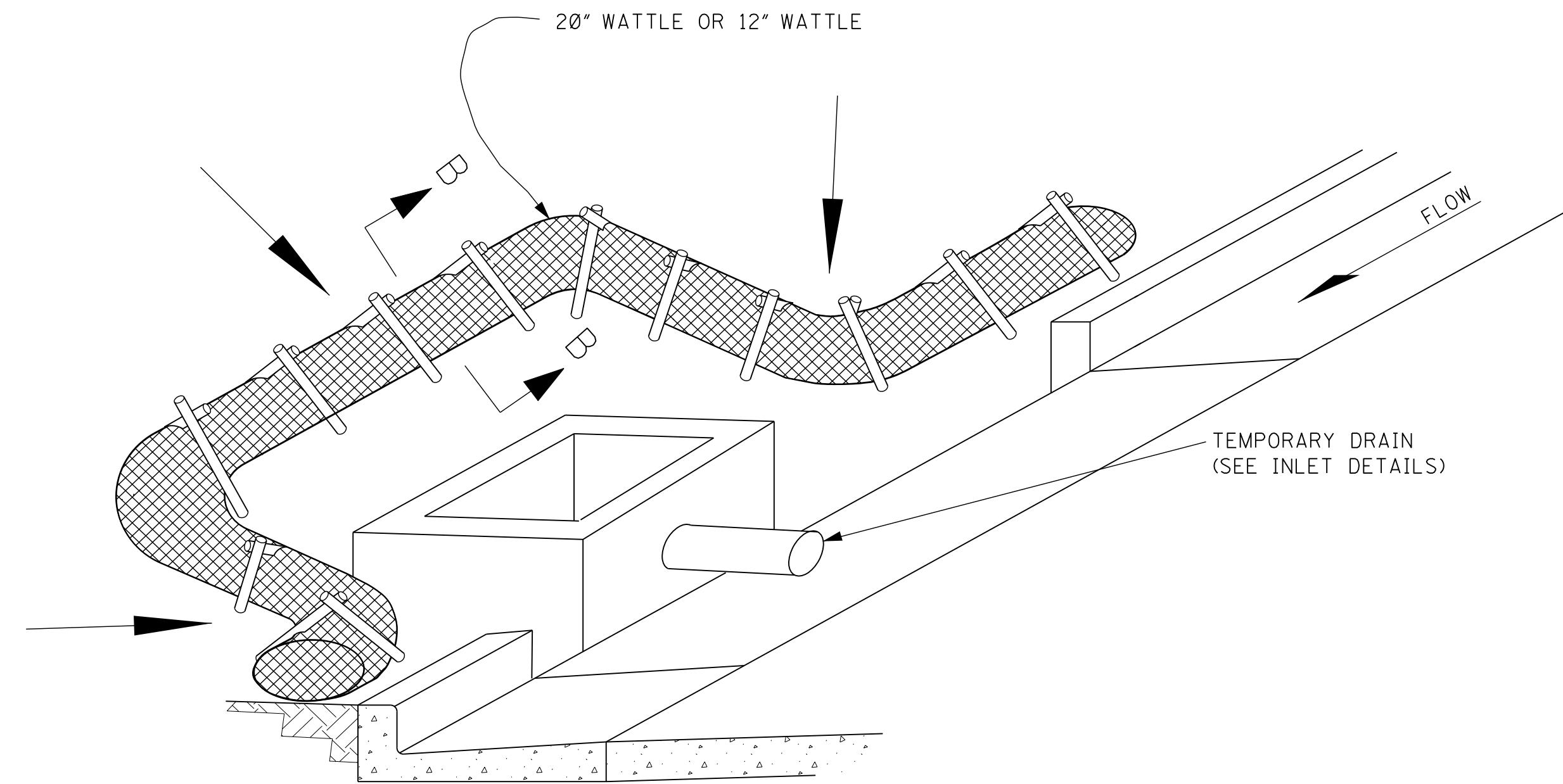

CURB INLET PROTECTION (STAGE 2)
SINGLE OR DOUBLE WING INLET

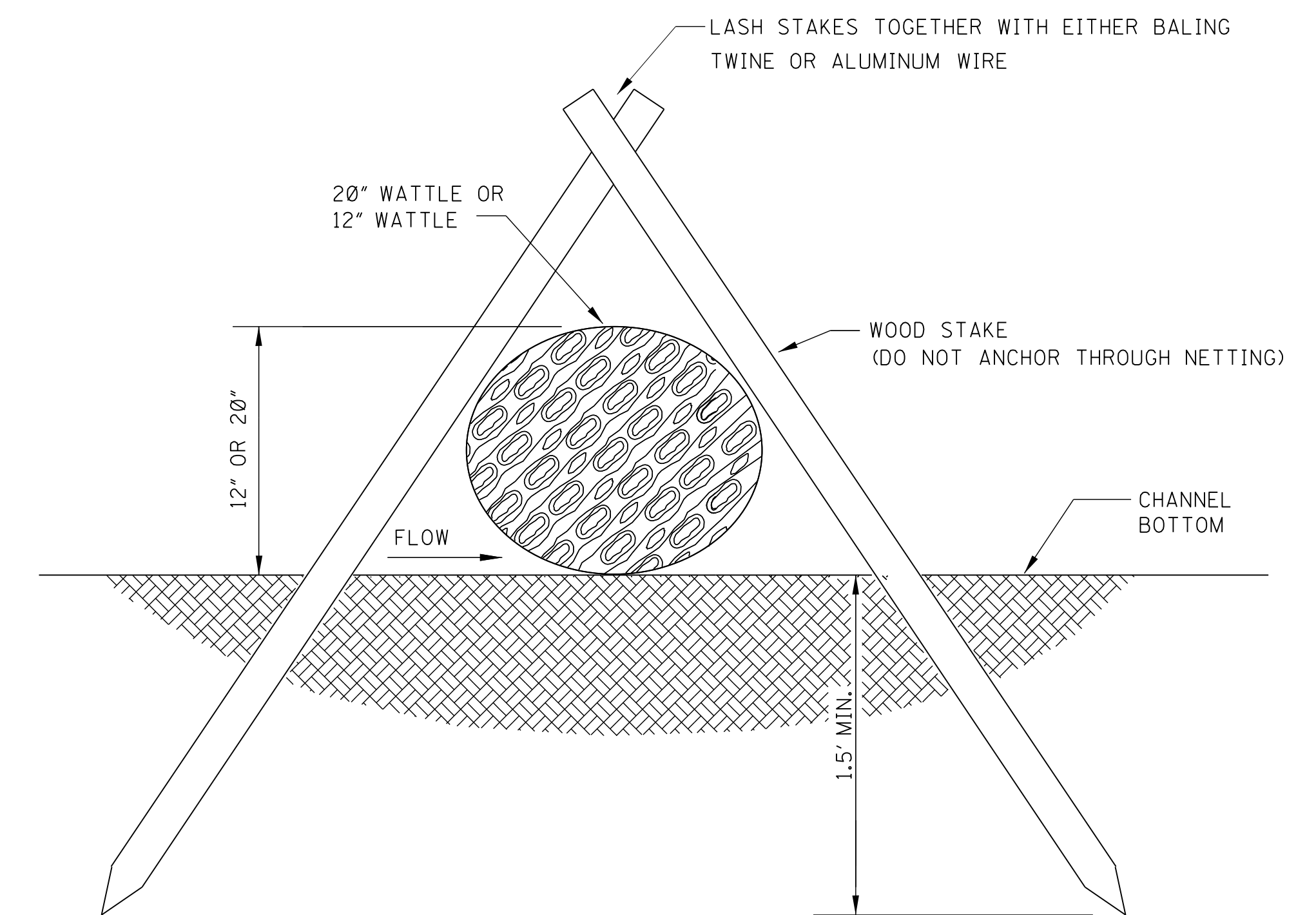

SECTION B-B

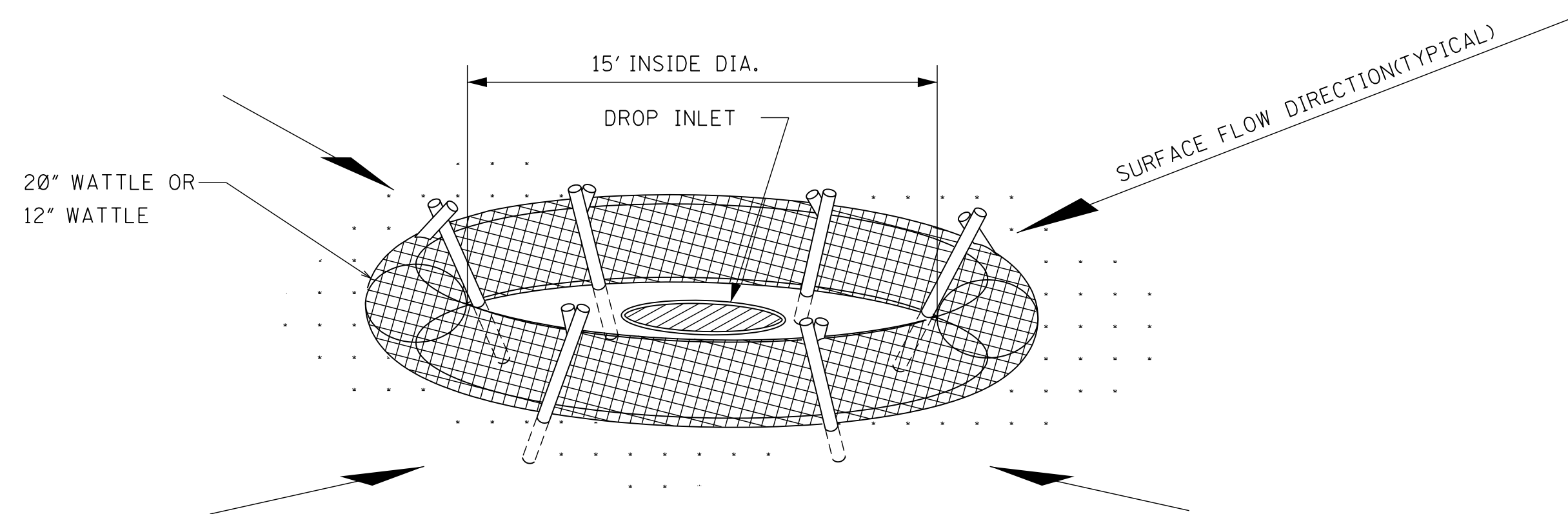

DROP INLET PROTECTION

NOTES:

1. ANCHORING STAKES SHALL BE SIZED, SPACED, AND BE OF A MATERIAL THAT EFFECTIVELY SECURES THE WATTLE. STAKE SPACING SHALL BE A MAXIMUM OF THREE FEET.
2. OVERLAP ENDS OF WATTLES PER MANUFACTURER'S RECOMMENDATIONS (1' MIN., 3' MAX.)
3. TRENCHING OF WATTLES MAY BE NECESSARY IF PIPING BECOMES EVIDENT.
4. IN THE EVENT WATTLES CANNOT BE SECURED IN PLACE USING WOOD STAKES, SANDBAGS MAY BE USED IN LIEU OF WOOD STAKES IN ORDER TO SECURE WATTLES IN PLACE. COST OF SANDBAGS USED IN THIS APPLICATION SHALL BE INCLUDED IN OTHER ITEMS BID.

		MISSISSIPPI DEPARTMENT OF TRANSPORTATION ROADWAY DESIGN DIVISION STANDARD PLAN	
		INLET PROTECTION DETAILS OF WATTLES	
		 WORKING NUMBER ECD-13 SHEET NUMBER 6113	
BY		ISSUE DATE: AUGUST 01, 2017	
REVISION			
DATE			

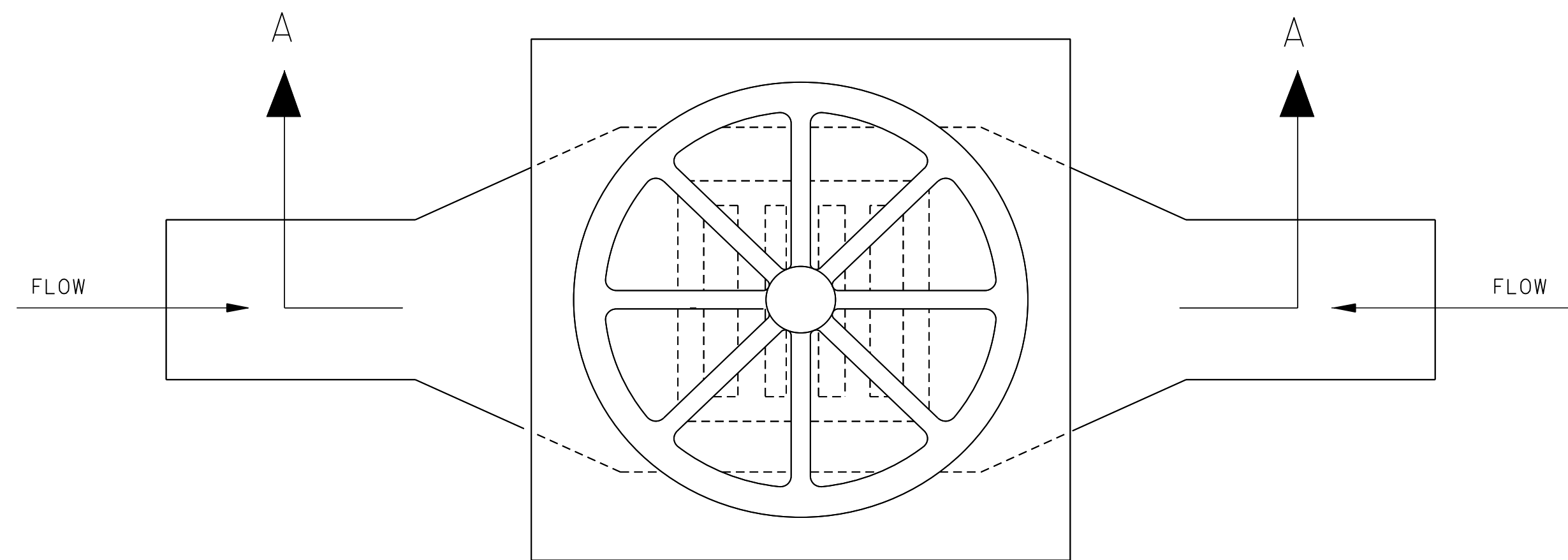

PLAN

NOTES:

1. FRAMES WITH EITHER SQUARE OR CIRCULAR BASES MAY BE USED. SELECTED FRAME BASE SHOULD PROVIDE BEST SEAL AROUND THE INLET AS DIRECTED BY THE ENGINEER.
2. FILL POCKETS AROUND BASE OF FILTER COVER WITH SEDIMENT CONTROL STONE. THE COST OF SEDIMENT CONTROL STONE USED IN THIS APPLICATION SHALL BE INCLUDED IN OTHER ITEMS BID.
3. USE ONLY DURING STAGE 3 OR STAGE 4 INLET CONSTRUCTION. SEE WK. NO. ECD-11.
4. FOR MEDIAN INLET PROTECTION, THE ELEVATION OF THE COARSE SCREEN TOP SHALL BE A MINIMUM OF 6" BELOW THE ELEVATION OF THE OUTSIDE EDGE OF THE INSIDE SHOULDER.

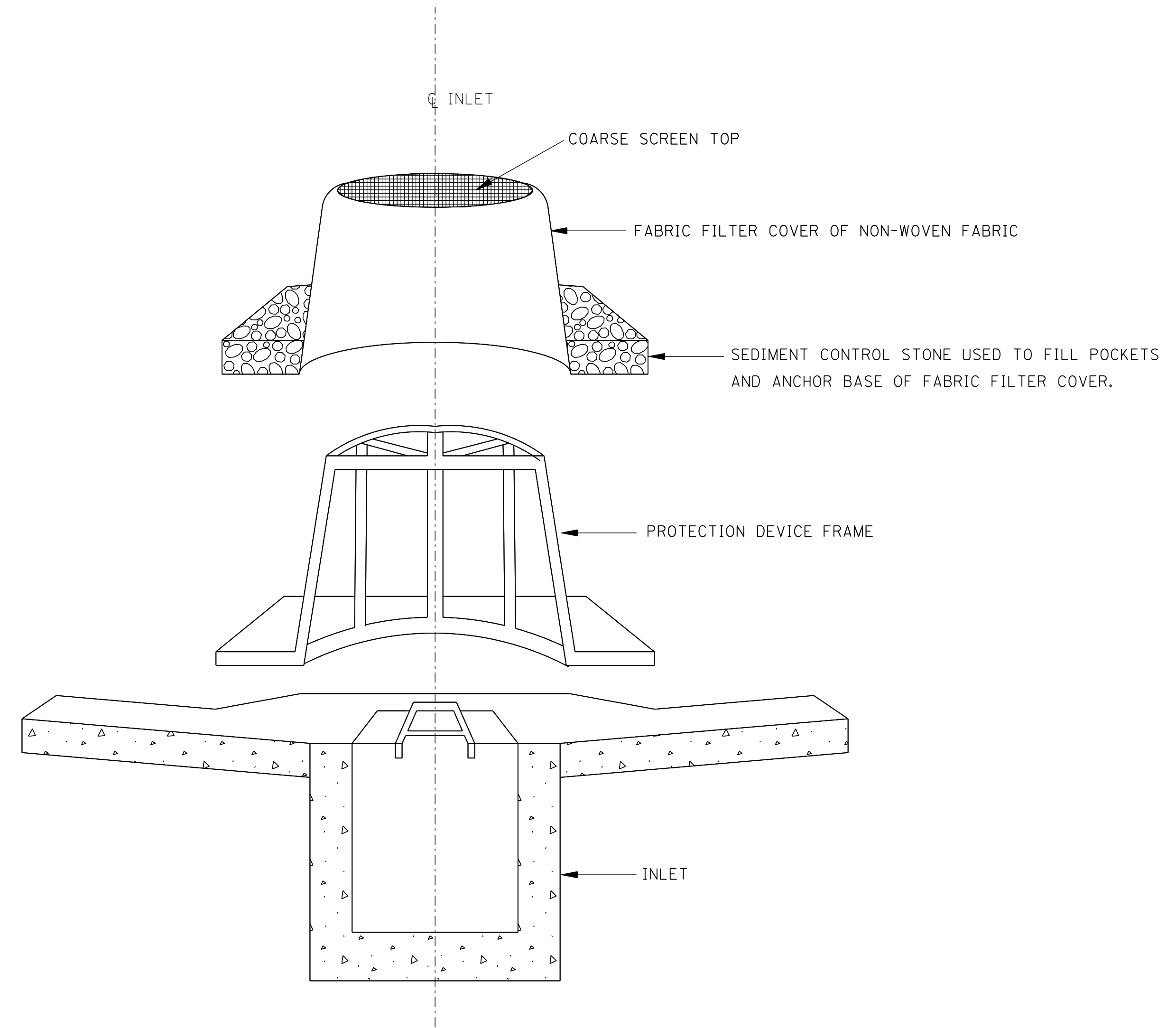

SECTION "A-A"

					MISSISSIPPI DEPARTMENT OF TRANSPORTATION ROADWAY DESIGN DIVISION STANDARD PLAN
					INLET PROTECTION DETAILS OF MANUFACTURED INLET PROTECTION DEVICE
					MDOT MISSISSIPPI DEPARTMENT OF TRANSPORTATION
					WORKING NUMBER ECD-14
					SHEET NUMBER 6114
					ISSUE DATE: AUGUST 01, 2017

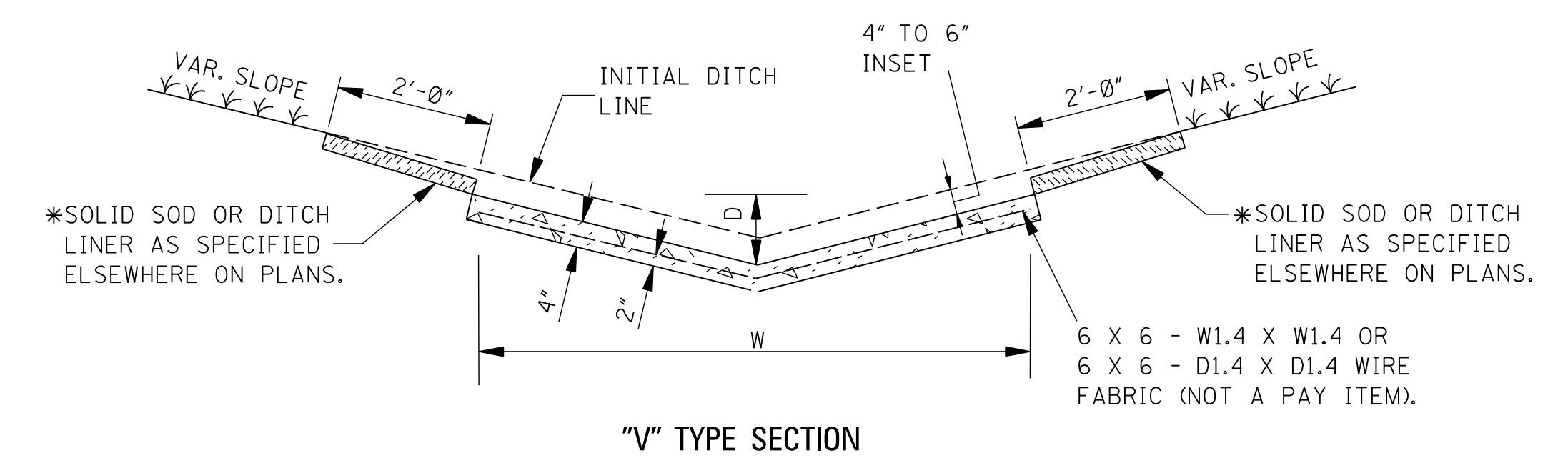

"V" TYPE SECTION

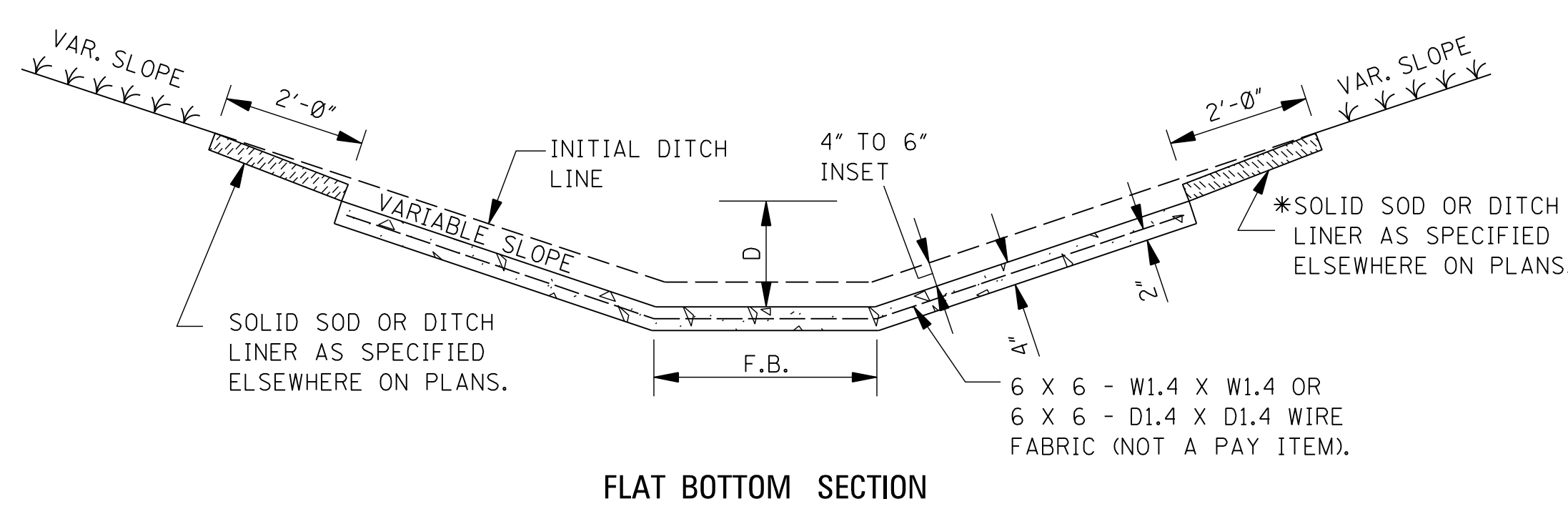

FLAT BOTTOM SECTION

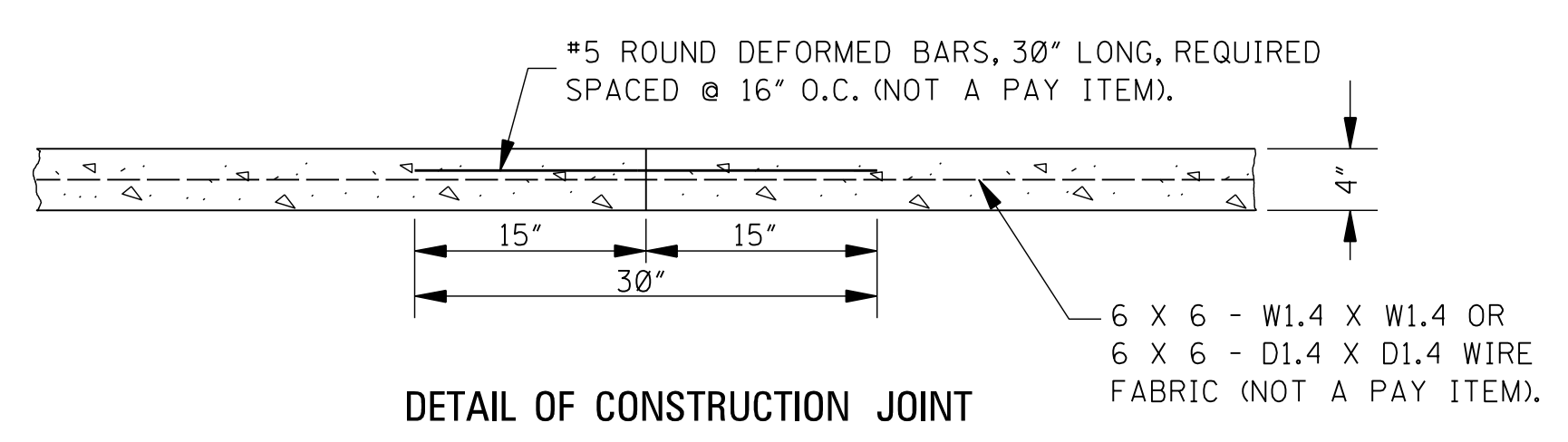

DETAIL OF CONSTRUCTION JOINT

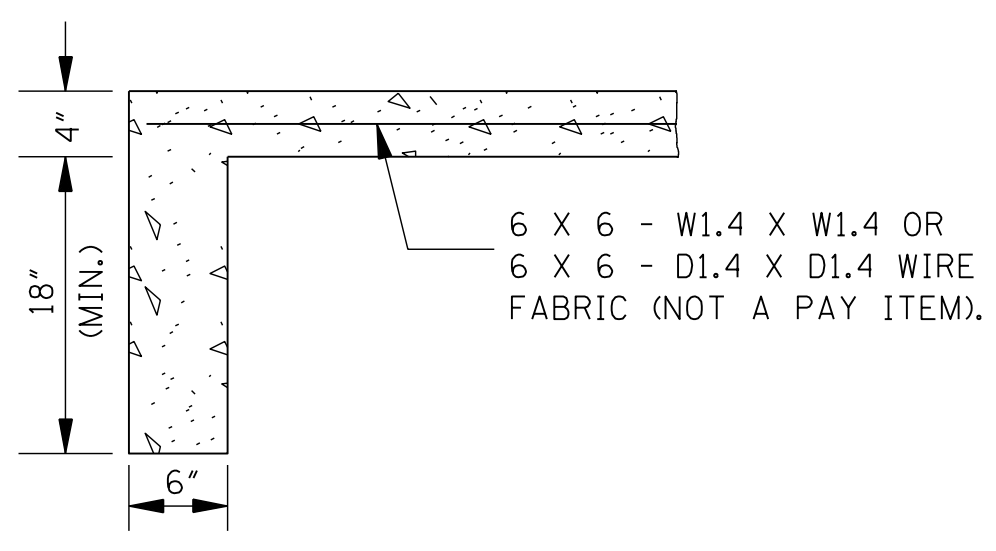

DETAIL OF TOE WALL
NOTE: TOE WALL REQUIRED UPSTREAM AND DOWNSTREAM.

CONCRETE PAVED DITCH

- NOTES:
- CONCRETE PAVED DITCHES SHALL BE GROOVED AT 20'-0" INTERVALS. THE GROOVES SHALL BE CUT TO A DEPTH OF NOT LESS THAN 1".
 - DIMENSIONS D & W ARE AS FOLLOWS:
D(MINIMUM) = 6"
D(NOMINAL) = 9"
W(MINIMUM) = 24"
 - CHAIR SUPPORTS FOR THE WIRE MESH WILL NOT BE REQUIRED. HOWEVER, THE CONTRACTOR SHALL PLACE THE WIRE MESH IN A SATISFACTORY AND WORKMANLIKE MANNER TO ENSURE THAT THE FINAL POSITION IS REASONABLY NEAR THE POSITION INDICATED.
 - * CENTER ROW OF STAPLES MAY BE OMITTED ON DITCH LINER.

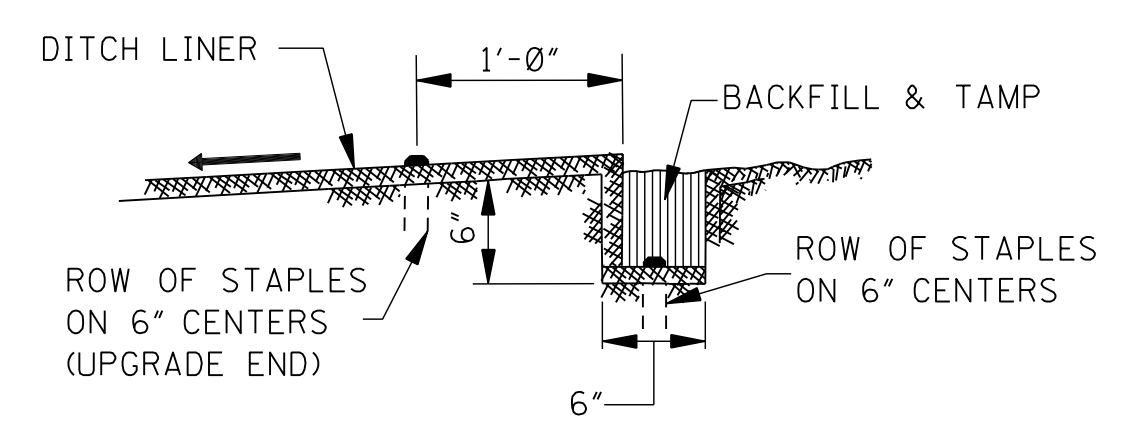

ANCHOR TRENCH DETAIL

NOTE: ANCHOR TRENCH REQUIRED AT THE BEGINNING AND ENDING OF EACH AREA TO BE COVERED, EXCEPT DOWNSTREAM END ADJOINING A STRUCTURE.

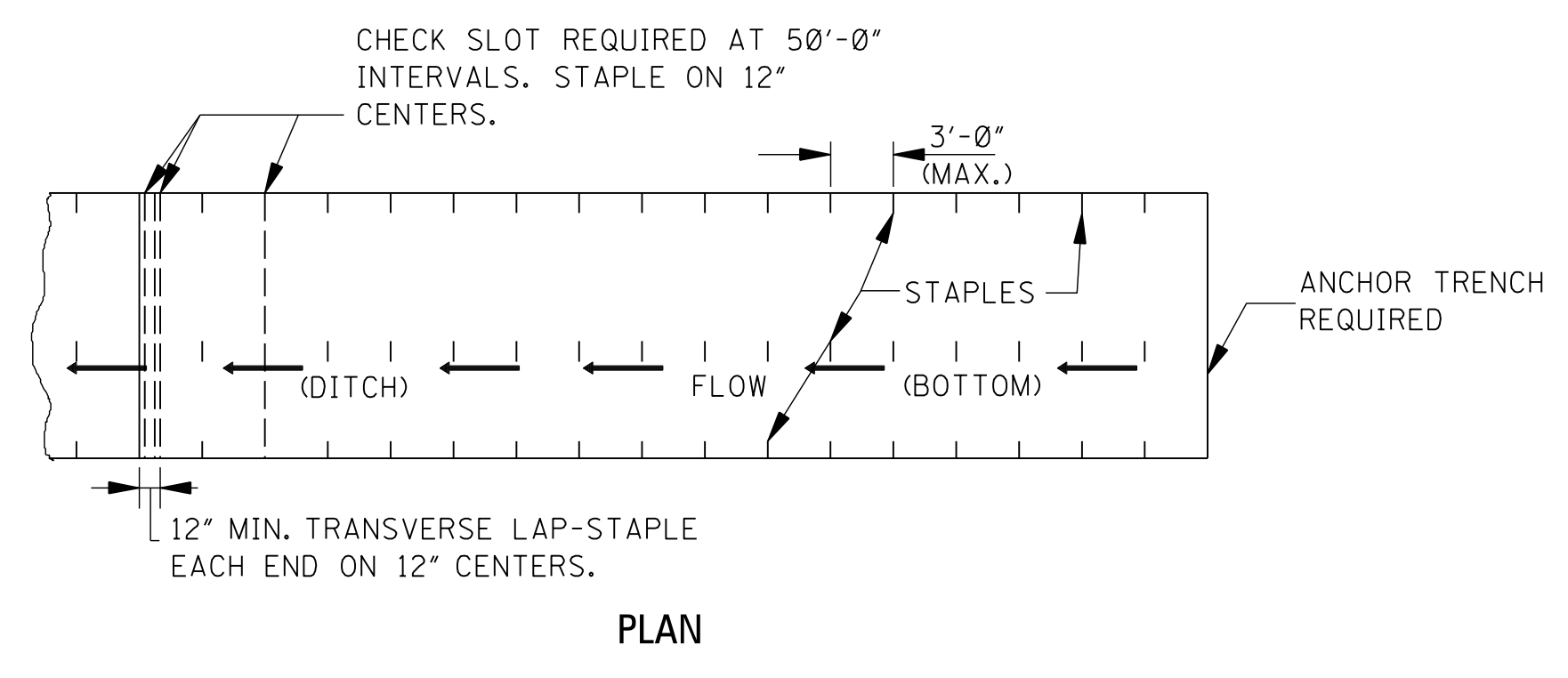

PLAN

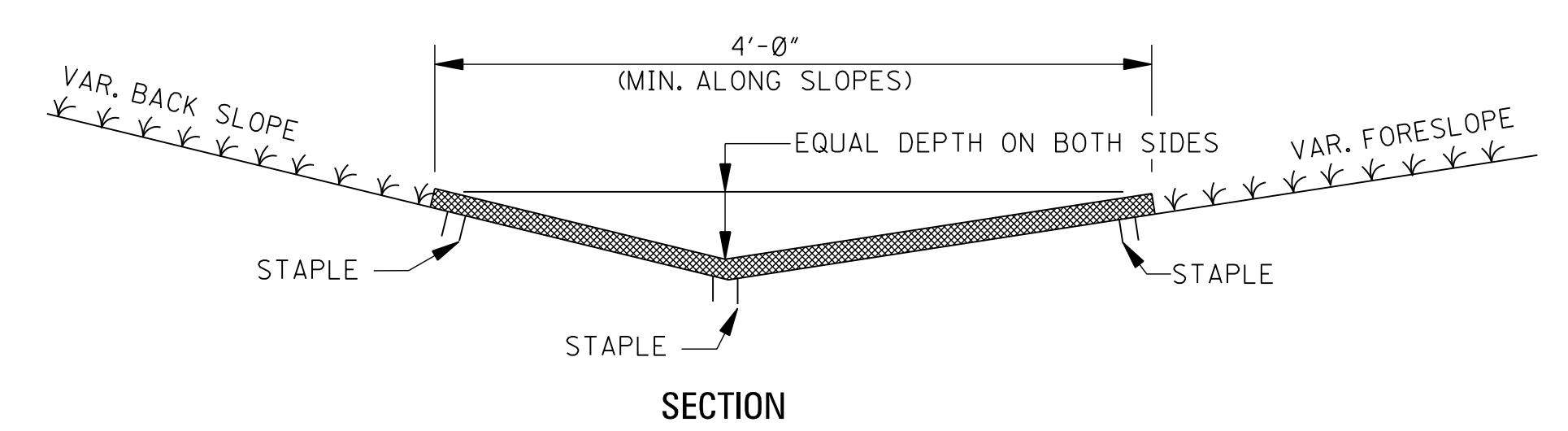

SECTION

DITCH LINER TREATMENT (EXCELSIOR BLANKET, JUTE MESH OR EROSION CONTROL FABRIC)

NOTE: DITCHES TREATED WITH DITCH LINER WILL BE VEGETATED PRIOR TO TREATMENT, UNLESS OTHERWISE INDICATED.

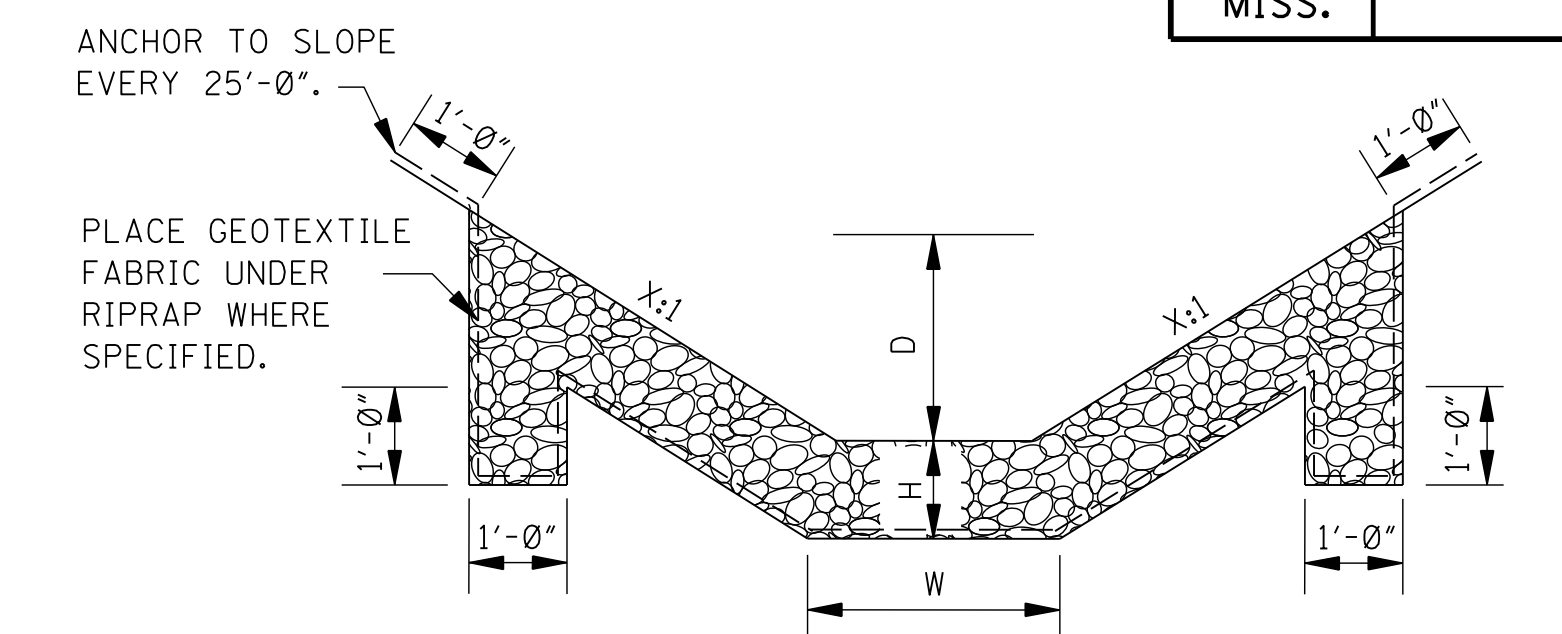

FLAT BOTTOM SECTION

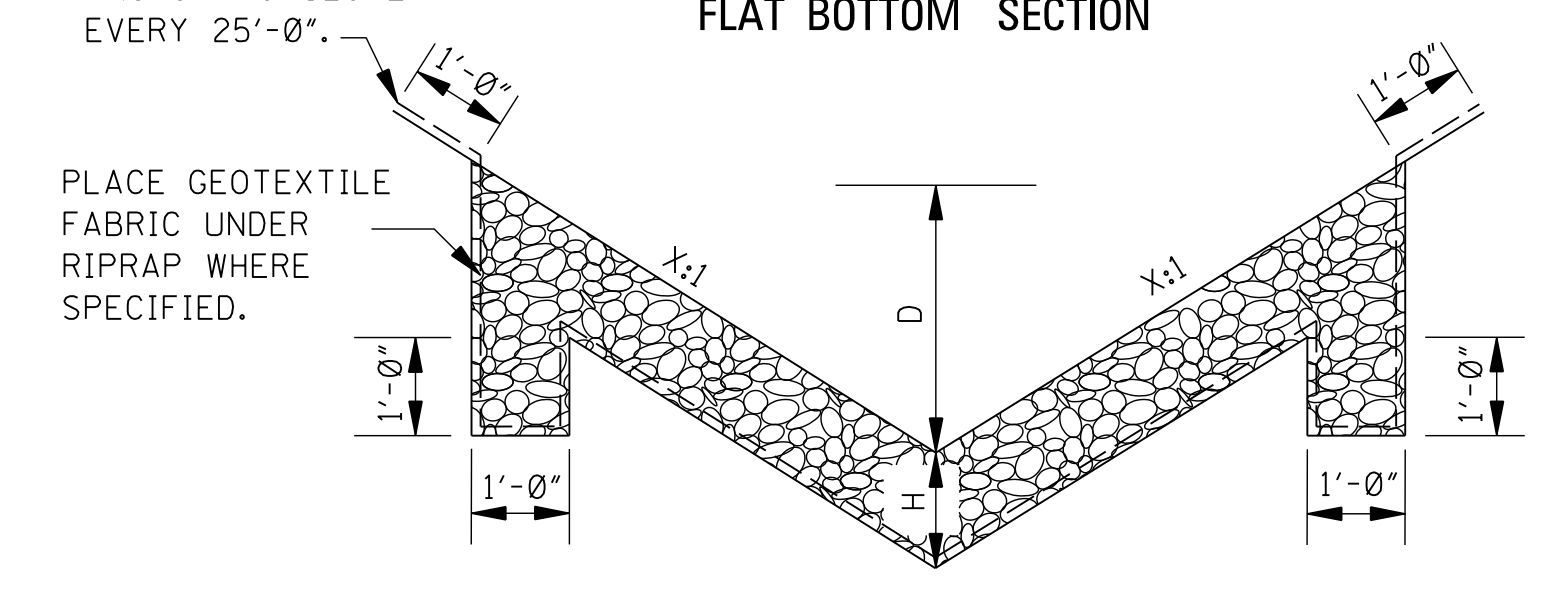

"V" TYPE SECTION
RIPRAP TREATMENT

- NOTES:
- DIMENSIONS D, W AND X ARE VARIABLE AND ARE SHOWN ELSEWHERE ON THE PLANS.
 - THE RIPRAP SIZE AND MINIMUM DEPTH "H" FOR RIPRAP TREATMENT ARE AS FOLLOWS.

RIPRAP SIZE & MINIMUM DEPTH "H"	
H (in)	RIPRAP SIZE (lbs)
12"	100
18"	300

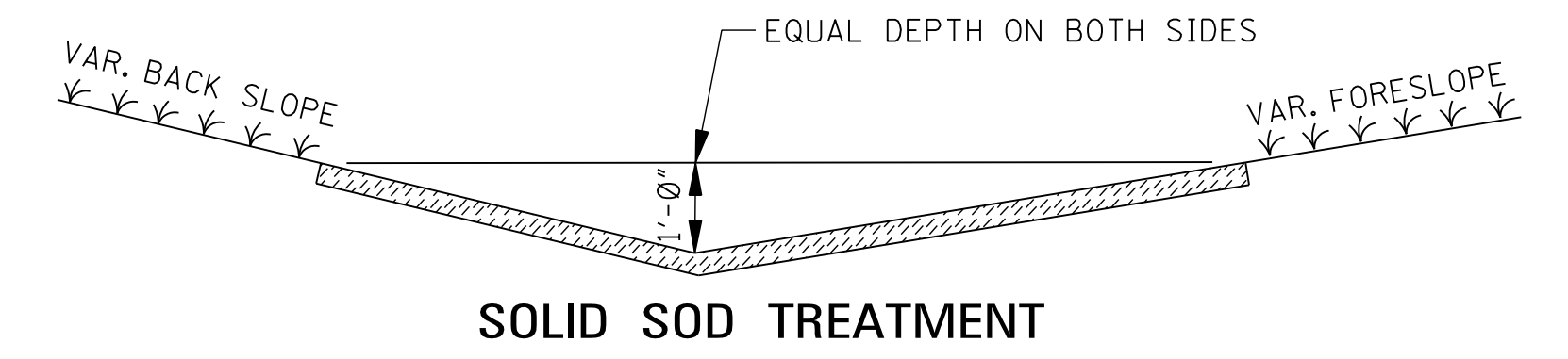

SOLID SOD TREATMENT

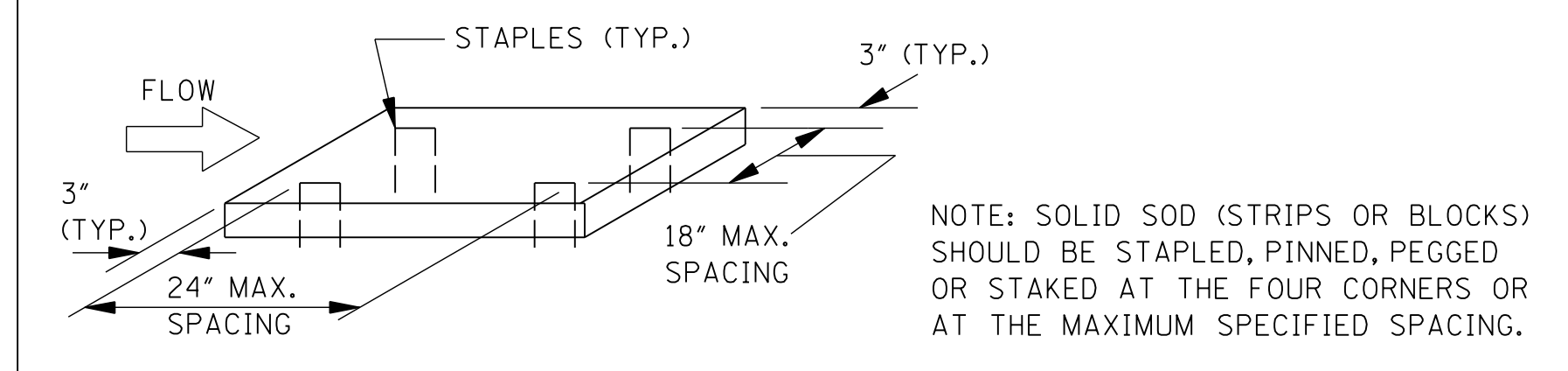

- GENERAL NOTE:
- FOR LOCATION OF APPROPRIATE DITCH TREATMENTS, SEE PLAN SHEETS AS DENOTED BY THE FOLLOWING LEGEND OR AS DIRECTED BY THE ENGINEER:

- DITCH LINER
- SOLID SOD
- CONCRETE PAVED DITCH
- RIPRAP

BY	MISSISSIPPI DEPARTMENT OF TRANSPORTATION ROADWAY DESIGN DIVISION STANDARD PLAN
REVISION	
DATE	ISSUE DATE: AUGUST 01, 2017

DETAILS OF TYPICAL DITCH TREATMENTS

WORKING NUMBER DT-1
SHEET NUMBER 6123

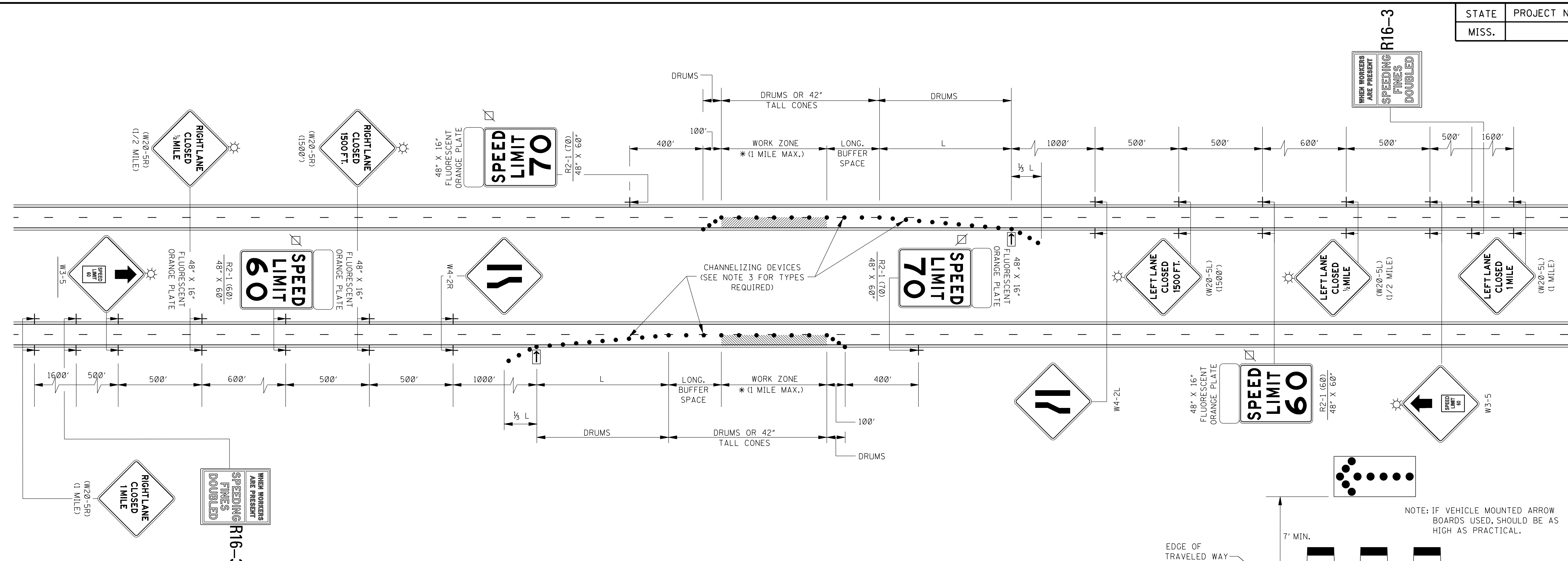

GENERAL NOTES:

1. THE LOCATION OF CHANNELIZING DEVICES AND THE WORK AREA LAYOUT SHALL BE BASED ON THE CRITERIA IN THE FOLLOWING TABLE:

POSTED SPEED AND/OR DESIGN SPEED	MAXIMUM CHANNELIZING DEVICE SPACING (f+)		LONGITUDINAL BUFFER SPACE (f+)	TAPER RATES
	TAPER	ALONG BUFFER SPACE & WORK ZONE		
≤40	40	80	305	27:1
45	45	90	360	45:1
50	50	100	425	50:1
55	55	110	495	55:1
60	60	120	570	60:1
65	65	130	645	65:1
70	70	140	730	70:1

+ NOTE: TAPER RATES ARE DETERMINED USING THE FOLLOWING EQUATIONS:
 $L = WS$ FOR SPEEDS OF 45 mph OR GREATER
 $L = WS^2/60$ FOR SPEEDS OF 40 mph OR LESS
 WHERE: L = MINIMUM LENGTH OF TAPER IN FEET
 W = WIDTH OF OFFSET (USUALLY LANE WIDTH) IN FEET
 S = DESIGN SPEED OR 85TH PERCENTILE SPEED IN MILES PER HOUR

++ NOTE: BUFFER SPACE MAY BE ADJUSTED AS NEEDED ACCORDING TO ROADWAY GEOMETRY TO MEET SIGHT DISTANCE REQUIREMENTS, AS DIRECTED BY THE ENGINEER.

2. FLASHING ARROW PANEL SHOULD BE AS LEVEL AS POSSIBLE AS APPROVED BY THE ENGINEER. FLASHING ARROW PANEL SHOULD BE LOCATED AT THE BEGINNING OF THE TAPER OR, IF THE SHOULDER IS TOO NARROW, BEHIND THE CHANNELIZING DEVICES IN THE CLOSED LANE.

3. CHANNELIZING DEVICES:

- A. ALL CHANNELIZING DEVICES IN TAPERS SHALL BE RETROREFLECTIVE FREE STANDING PLASTIC DRUMS.
- B. CHANNELIZING DEVICES IN TANGENTS MAY BE EITHER RETROREFLECTIVE FREE STANDING PLASTIC DRUMS OR 42" TALL CONES.
- C. ALL CHANNELIZING DEVICES SHALL BE RETROREFLECTIVE.
- D. RETROREFLECTORIZATION SHALL BE IN ACCORDANCE WITH THE LATEST EDITION OF THE M.U.T.C.D.

4. DIAMOND SHAPED TRAFFIC CONTROL SIGNS SHOULD BE A MINIMUM OF 48" X 48", AND SHALL BE BLACK COPY ON FLUORESCENT ORANGE SHEETING.

5. ALL EXISTING SPEED LIMIT SIGNS WHICH ARE INFLUENCED BY OR CONFLICT WITH THE SPEED ZONE REDUCTION SHALL BE COVERED AS DIRECTED BY THE ENGINEER WHILE THE REDUCED SPEED LIMIT IS IN EFFECT. TAPE SHALL NOT BE USED ON FACE OF SIGN.

6. ADDITIONAL REDUCED REGULATORY SPEED LIMIT SIGNS ARE REQUIRED AT EACH ENTRANCE RAMP WITHIN THE SPEED ZONE. TWO (2) WILL BE REQUIRED FOR EACH RAMP AND LOCATION WILL BE DETERMINED BY THE ENGINEER.

7. THIS TRAFFIC CONTROL PLAN, WITH SPEED ZONE, MAY NOT BE USED ON ANY FACILITY WHERE THE POSTED SPEED LIMIT IS BELOW 65 MPH WITHOUT A COMMISSION ORDER REQUESTING A SPEED LIMIT REDUCTION.

8. LAYOUT SHOWN ABOVE IS FOR AN INTERSTATE WITH A POSTED SPEED LIMIT OF 70 MPH. FOR POSTED SPEED LIMIT OF 65 MPH, THE REDUCED SPEED LIMIT WILL BE 55 MPH.

9. A FLUORESCENT ORANGE PLATE IS REQUIRED WITH ALL REGULATORY SPEED LIMIT SIGNS REQUIRED FOR LANE CLOSURE.

10. ALL TRAFFIC CONTROL ITEMS SHOWN ON THIS SHEET WILL NOT BE MEASURED FOR SEPARATE PAYMENT. THIS WORK SHALL BE INCLUDED IN THE PRICE BID FOR MAINTENANCE OF TRAFFIC.

NOTE: IF VEHICLE MOUNTED ARROW BOARDS USED, SHOULD BE AS HIGH AS PRACTICAL.

LEGEND

- * OR AS SHOWN ELSEWHERE ON THE PLANS.
- FLASHING ARROW PANEL (TYPE "C")
- BLACK LEGEND AND BORDER ON WHITE BACKGROUND
- ☼ TYPE "B" WARNING LIGHTS
- RETROREFLECTIVE FREE-STANDING PLASTIC DRUMS

MISSISSIPPI DEPARTMENT OF TRANSPORTATION ROADWAY DESIGN DIVISION STANDARD PLAN	
TRAFFIC CONTROL PLAN FOR POSTED SPEED LIMIT OF 65 OR 70 MPH (INTERSTATES AND OTHER 4-LANE DIVIDED HIGHWAYS) (MEDIAN LANE OR OUTSIDE LANE CLOSURE) (EXTENDED PERIOD)	
BY	
REVISION	
DATE	ISSUE DATE: AUGUST 01, 2017
WORKING NUMBER TCP-4 SHEET NUMBER 6354	

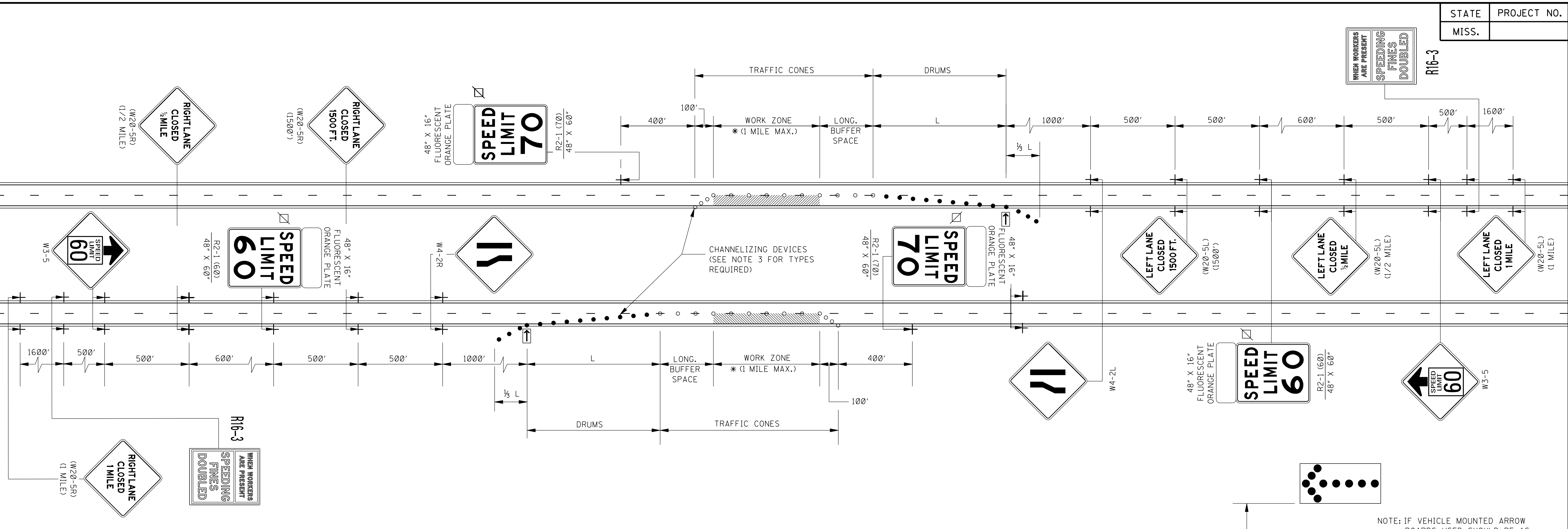

GENERAL NOTES:

1. THE LOCATION OF CHANNELIZING DEVICES AND THE WORK AREA LAYOUT SHALL BE BASED ON THE CRITERIA IN THE FOLLOWING TABLE:

POSTED SPEED AND/OR DESIGN SPEED	MAXIMUM CHANNELIZING DEVICE SPACING (ft)		LONGITUDINAL BUFFER SPACE (ft)	TAPER RATES
	TAPER	ALONG LANE LINE & WORK ZONE		
40	40	80	305	27:1
45	45	90	360	45:1
50	50	100	425	50:1
55	55	110	495	55:1
60	60	120	570	60:1
65	65	130	645	65:1
70	70	140	730	70:1

+ NOTE: TAPER RATES ARE DETERMINED USING THE FOLLOWING EQUATIONS:
 $L = WS$ FOR SPEEDS OF 45 mph OR GREATER
 $L = WS^2/60$ FOR SPEEDS OF 40 mph OR LESS
 WHERE: L = MINIMUM LENGTH OF TAPER IN FEET
 W = WIDTH OF OFFSET (USUALLY LANE WIDTH) IN FEET
 S = DESIGN SPEED OR 85TH PERCENTILE SPEED IN MILES PER HOUR

++ NOTE: BUFFER SPACE MAY BE ADJUSTED AS NEEDED ACCORDING TO ROADWAY GEOMETRY TO MEET SIGHT DISTANCE REQUIREMENTS, AS DIRECTED BY THE ENGINEER.

2. FLASHING ARROW PANEL SHOULD BE AS LEVEL AS POSSIBLE AS APPROVED BY THE ENGINEER. FLASHING ARROW PANEL SHOULD BE LOCATED AT THE BEGINNING OF THE TAPER OR, IF THE SHOULDER IS TOO NARROW, BEHIND THE CHANNELIZING DEVICES IN THE CLOSED LANE.

- CHANNELIZING DEVICE TYPES FOR:
 - APPROACH TAPER- RETROREFLECTIVE PLASTIC DRUMS
 - ALONG LANE LINE AND WORK ZONE- TRAFFIC CONES (28" HEIGHT MINIMUM)
 - EXIT TAPER- TRAFFIC CONES (28" HEIGHT MINIMUM)
- WHEN WORK ZONE IS NO LONGER NEEDED, ALL SIGNS SHALL BE COVERED OR REMOVED AND THE DRUMS SHALL BE MOVED TO THE SHOULDER EDGE AT THE END OF THE WORK DAY.
- FOR MOVING OPERATIONS (PAVING) THE CONTRACTOR SHALL HAVE TWO (2) SETS OF ADVANCE WARNING AND REGULATORY SIGNS, PLASTIC DRUMS, AND ARROW BOARD. WHEN THE CONSTRUCTION ZONE IS MOVED AHEAD, ALL SIGNS, PLASTIC DRUMS AND ARROW BOARD SHALL BE IN PLACE ON THE SECOND ZONE BEFORE REMOVING ANY SIGNS, PLASTIC DRUMS OR ARROW BOARD ON THE FIRST ZONE.
- DIAMOND SHAPED TRAFFIC CONTROL SIGNS SHOULD BE A MINIMUM OF 48" X 48". AND SHALL BE BLACK COPY ON FLUORESCENT ORANGE SHEETING.
- ALL EXISTING SPEED LIMIT SIGNS WHICH ARE INFLUENCED BY OR CONFLICT WITH THE SPEED ZONE REDUCTION SHALL BE COVERED AS DIRECTED BY THE ENGINEER WHILE THE REDUCED SPEED LIMIT IS IN EFFECT. TAPE SHALL NOT BE USED ON THE FACE OF SIGN.
- ADDITIONAL REDUCED REGULATORY SPEED LIMIT SIGNS ARE REQUIRED AT EACH ENTRANCE RAMP WITHIN THE SPEED ZONE. TWO (2) WILL BE REQUIRED FOR EACH RAMP AND LOCATION WILL BE DETERMINED BY THE ENGINEER.
- THIS TRAFFIC CONTROL PLAN, WITH SPEED ZONE, MAY NOT BE USED ON ANY FACILITY WHERE THE POSTED SPEED LIMIT IS BELOW 65 MPH WITHOUT A COMMISSION ORDER REQUESTING A SPEED LIMIT REDUCTION.
- LAYOUT SHOWN ABOVE IS FOR AN INTERSTATE WITH A POSTED SPEED LIMIT OF 70 MPH. FOR POSTED SPEED LIMIT OF 65 MPH, THE REDUCED SPEED LIMIT WILL BE 55 MPH.
- A FLUORESCENT ORANGE PLATE IS REQUIRED WITH ALL REGULATORY SPEED LIMIT SIGNS AND "REDUCED SPEED AHEAD" SIGNS REQUIRED FOR LANE CLOSURE.
- ALL TRAFFIC CONTROL ITEMS SHOWN ON THIS SHEET WILL NOT BE MEASURED FOR SEPARATE PAYMENT. THIS WORK SHALL BE INCLUDED IN THE PRICE BID FOR MAINTENANCE OF TRAFFIC.

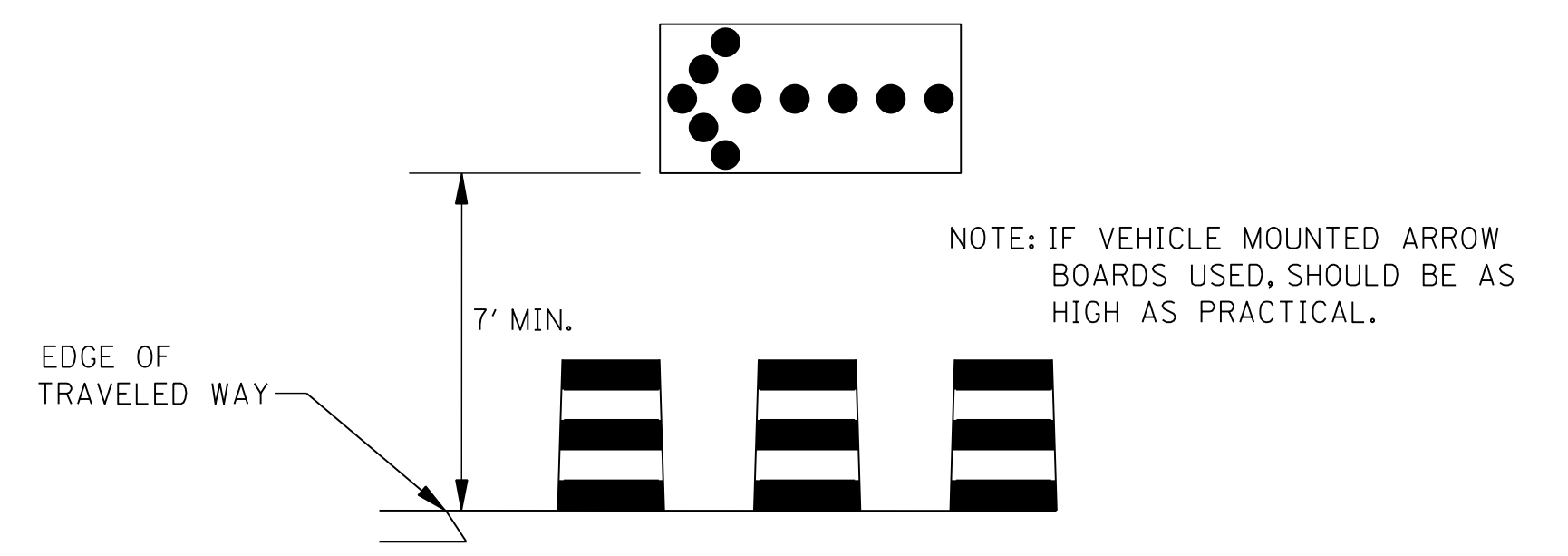

LEGEND

- * OR AS SHOWN ELSEWHERE ON THE PLANS.
- FLASHING ARROW PANEL (TYPE "C")
- BLACK LEGEND AND BORDER ON WHITE BACKGROUND
- RETROREFLECTIVE FREE-STANDING PLASTIC DRUMS
- TRAFFIC CONES (28" HEIGHT)

BY	MISSISSIPPI DEPARTMENT OF TRANSPORTATION ROADWAY DESIGN DIVISION
REVISION	STANDARD PLAN TRAFFIC CONTROL PLAN FOR POSTED SPEED LIMIT OF 65 OR 70 MPH (INTERSTATES AND OTHER 4-LANE DIVIDED HIGHWAYS) (MEDIAN LANE OR OUTSIDE LANE CLOSURE) (WORK DAY ONLY)
DATE	ISSUE DATE: AUGUST 01, 2017

WORKING NUMBER TCP-5
 SHEET NUMBER 6355

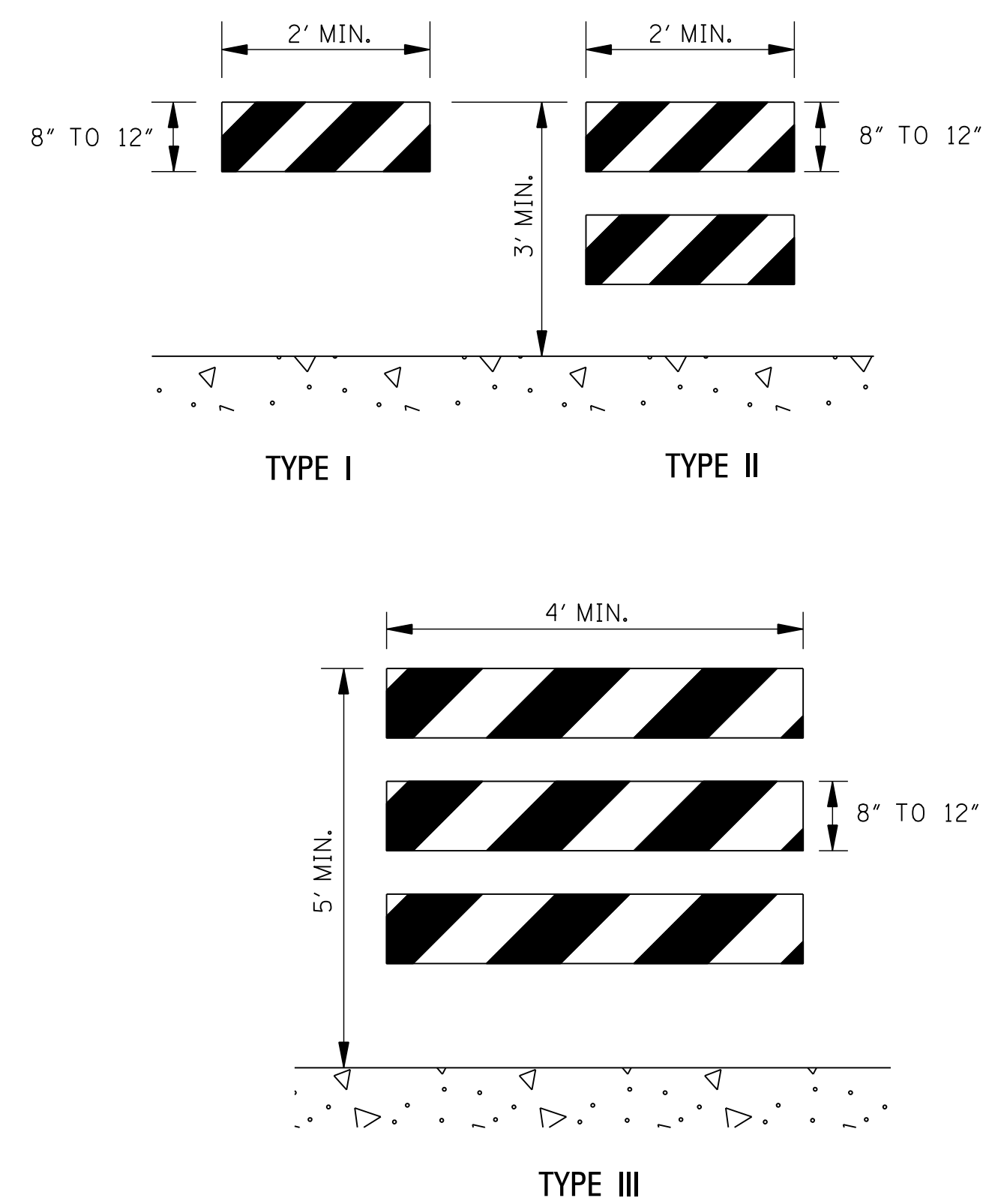

STANDARD BARRICADES

1. THE MARKING FOR BARRICADE RAILS SHALL BE ORANGE AND WHITE (SLOPING DOWNWARD AT AN ANGLE OF 45° IN THE DIRECTION TRAFFIC IS TO PASS).
2. RAIL STRIPE SHOULD BE 6 INCHES, EXCEPT THAT 4-INCH WIDE STRIPES MAY BE USED IF RAIL LENGTHS ARE LESS THAN 36 INCHES.
3. DO NOT PLACE SANDBAGS OR OTHER DEVICES TO PROVIDE MASS ON THE BOTTOM RAIL THAT WILL BLOCK VIEW OR RAIL FACE.
4. FOR ADDITIONAL INFORMATION OR DETAILS, SEE MUTCD, LATEST EDITION.
5. BARRICADES ARE CLASSIFIED BY FHWA AS CATEGORY II WORK ZONE DEVICES WHICH REQUIRE CRASHWORTHINESS ACCEPTANCE LETTERS. TO DATE, 2-IN. THICK TIMBER RAILS HAVE NOT BEEN SUCCESSFULLY CRASH TESTED. A LIST OF CRASHWORTHY BARRICADES AND OTHER CATEGORY II DEVICES CAN BE FOUND ON FHWA'S WEBSITE:
http://safety.fhwa.dot.gov/roadway_dept/policy_guide/road_hardware/cat2.cfm

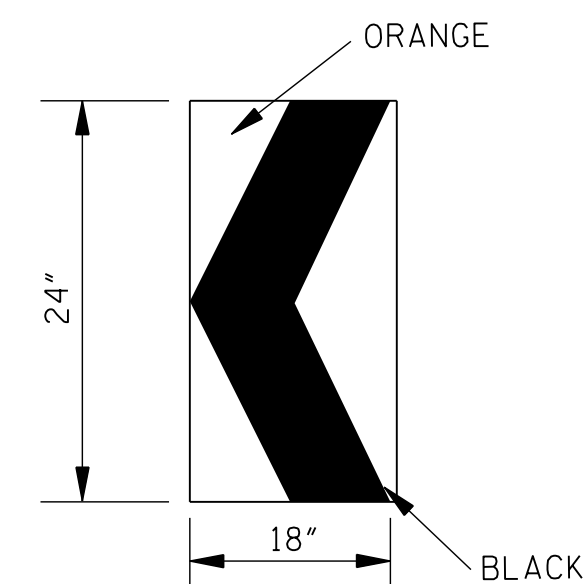

**CHEVRON SIGN
DETAIL**

1. A CHEVRON SIGN CONSISTS OF A BLACK CHEVRON TYPE MARKING ON AN ORANGE BACKGROUND AND SHALL POINT IN THE DIRECTION OF TRAFFIC FLOW.
2. THE CHEVRON SIGN SHALL BE MOUNTED ON CRASHWORTHY SUPPORT.
3. CHEVRON SIGNS MAY BE USED TO SUPPLEMENT OTHER STANDARD DEVICES WHERE ONE OR MORE LANES ARE CLOSED FOR CONSTRUCTION OR MAINTENANCE. THEY SHOULD BE PLACED APPROXIMATELY 2'-0" BEHIND THE LANE TRANSITION STRIPE.

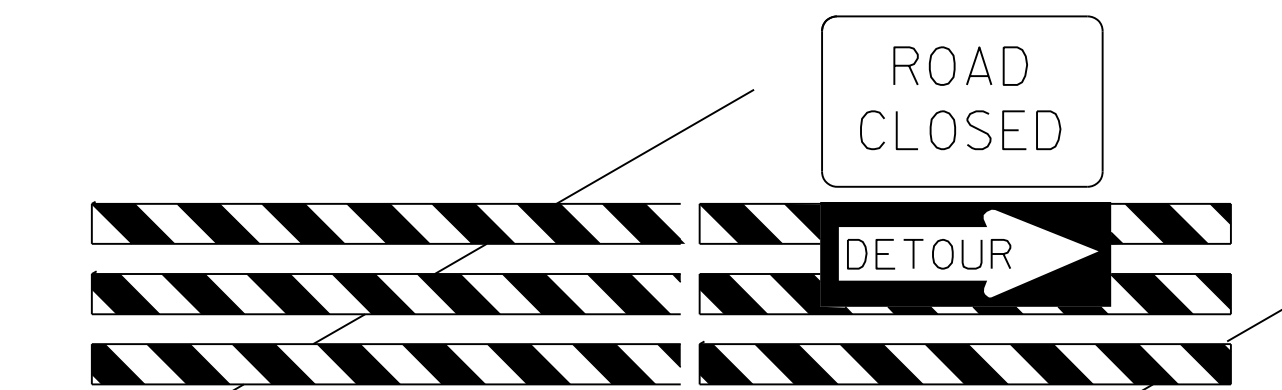

BARRICADE CLOSING A ROAD

BARRICADE CHARACTERISTICS

	I	II	III
WIDTH OF RAIL **	8" MIN. - 12" MAX.	8" MIN. - 12" MAX.	8" MIN. - 12" MAX.
LENGTH OF RAIL **	24" MIN.	24" MIN.	48" MIN.
WIDTH OF STRIPE *	6"	6"	6"
HEIGHT	36" MIN.	36" MIN.	60" MIN.
NUMBER OF RETROREFLECTORIZED RAIL FACES	2 (ONE EACH DIRECTION)	4 (TWO EACH DIRECTION)	3 IF FACING TRAFFIC IN ONE DIRECTION 6 IF FACING TRAFFIC IN TWO DIRECTIONS

- * 1. FOR RAILS LESS THAN 36" LONG, 4" WIDE STRIPES MAY BE USED.
- ** 2. BARRICADES INTENDED FOR USE ON EXPRESSWAYS, FREEWAYS AND OTHER HIGH SPEED ROADWAYS, SHALL HAVE A MINIMUM OF 270 in² OF REFLECTIVE AREA FACING TRAFFIC.

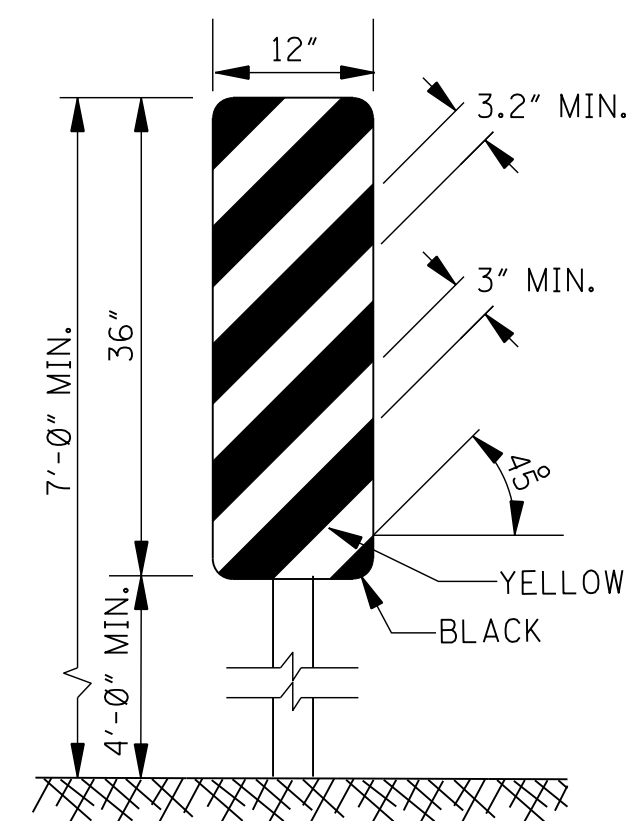

**TYPE 3 OBJECT MARKER
(OM-3R)**

1. TYPE 3 OBJECT MARKERS SHALL BE USED AT ALL EXPOSED BRIDGE ABUTMENTS AND AT OTHER LOCATIONS AS DEEMED NECESSARY BY THE ENGINEER.
2. THE OM-3R IS SHOWN. THE OM-3L IS SIMILAR EXCEPT THE STRIPES SLOPE DOWNWARD FROM THE UPPER LEFT SIDE TO THE LOWER RIGHT SIDE AND SHALL BE PLACED ON THE LEFT SIDE OF THE OBJECT.
3. THE INSIDE EDGE OF THE MARKER SHALL BE IN LINE WITH THE INNER EDGE OF THE OBSTRUCTION.

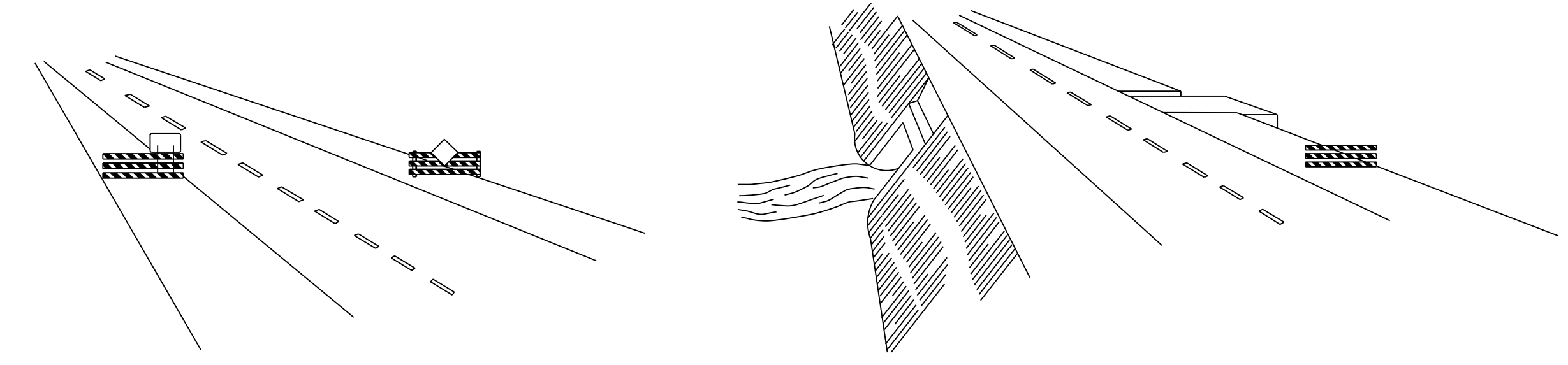

WING BARRICADES

1. WING BARRICADES ARE TYPE III BARRICADES ERECTED ON THE SHOULDER ON ONE OR BOTH SIDES OF THE PAVEMENT TO GIVE THE SENSATION OF A NARROWING OR RESTRICTED ROADWAY. WING BARRICADES MAY BE USED AS A MOUNTING FOR THE ADVANCE WARNING SIGNS OR FLASHERS.
2. WING BARRICADES SHOULD BE USED:
 - A. IN ADVANCE OF A CONSTRUCTION PROJECT EVEN WHEN NO PART OF THE ROADWAY IS ACTUALLY CLOSED.
 - B. IN ADVANCE OF ALL BRIDGE OR CULVERT WIDENING OPERATIONS.

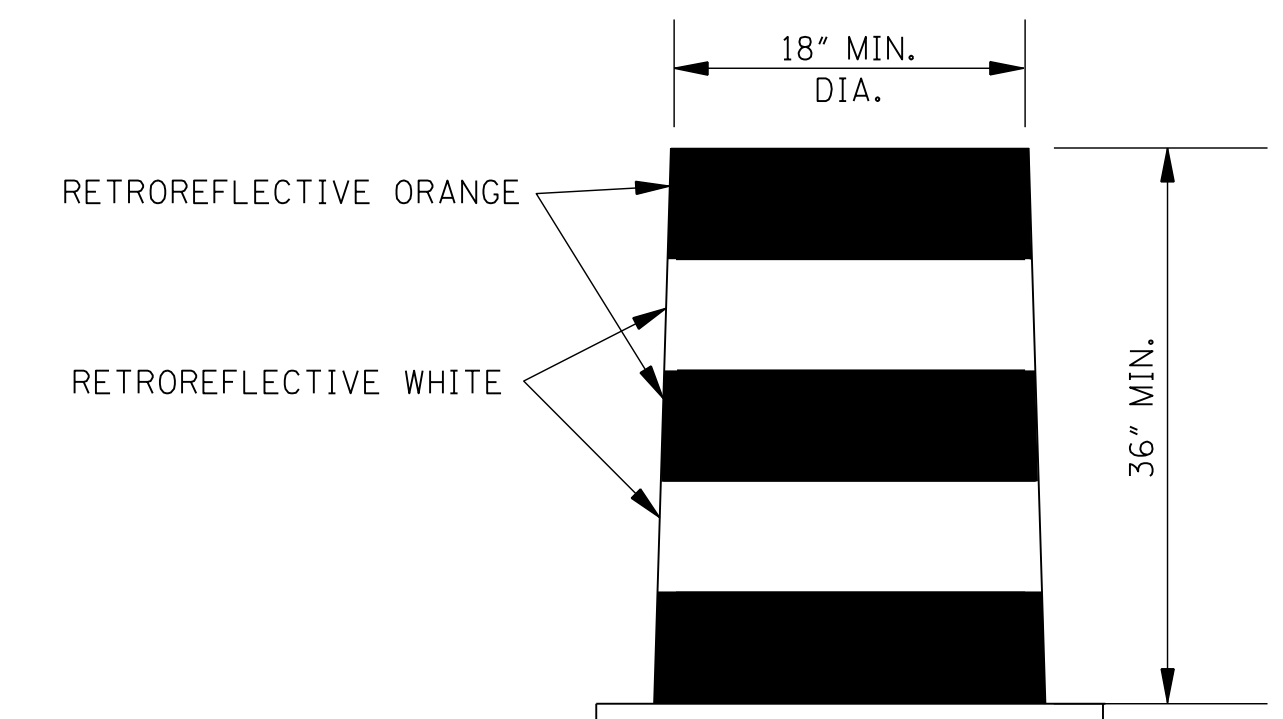

PLASTIC DRUM STRIPING DETAIL

1. PLASTIC DRUMS SHALL BE ON END AND USED AS AN EXPEDIENT METHOD FOR TRAFFIC CHANNELIZATION. THE COLOR AND MARKING OF DRUMS SHALL BE CONSISTENT WITH MARKING STANDARDS FOR BARRICADE. THE PREDOMINANT COLOR ON DRUMS SHALL BE ORANGE WITH FOUR (4) RETROREFLECTIVE, HORIZONTAL, CIRCUMFERENTIAL STRIPES (2 ORANGE & 2 WHITE) 6" WIDE.
2. DRUMS SHOULD NEVER BE PLACED IN THE ROADWAY WITHOUT WARNING SIGNS.
3. WHERE PRACTICAL PLASTIC DRUMS SHOULD BE PLACED NO CLOSER THAN 3'-0" FROM THE EDGE OF TRAVELED LANE.

BY		MISSISSIPPI DEPARTMENT OF TRANSPORTATION ROADWAY DESIGN DIVISION STANDARD PLAN	
REVISION		<p align="center">HIGHWAY SIGN AND BARRICADE DETAILS FOR CONSTRUCTION PROJECTS</p>	
DATE			
ISSUE DATE:		AUGUST 01, 2017	



WORKING NUMBER
TCP-8
SHEET NUMBER
6358

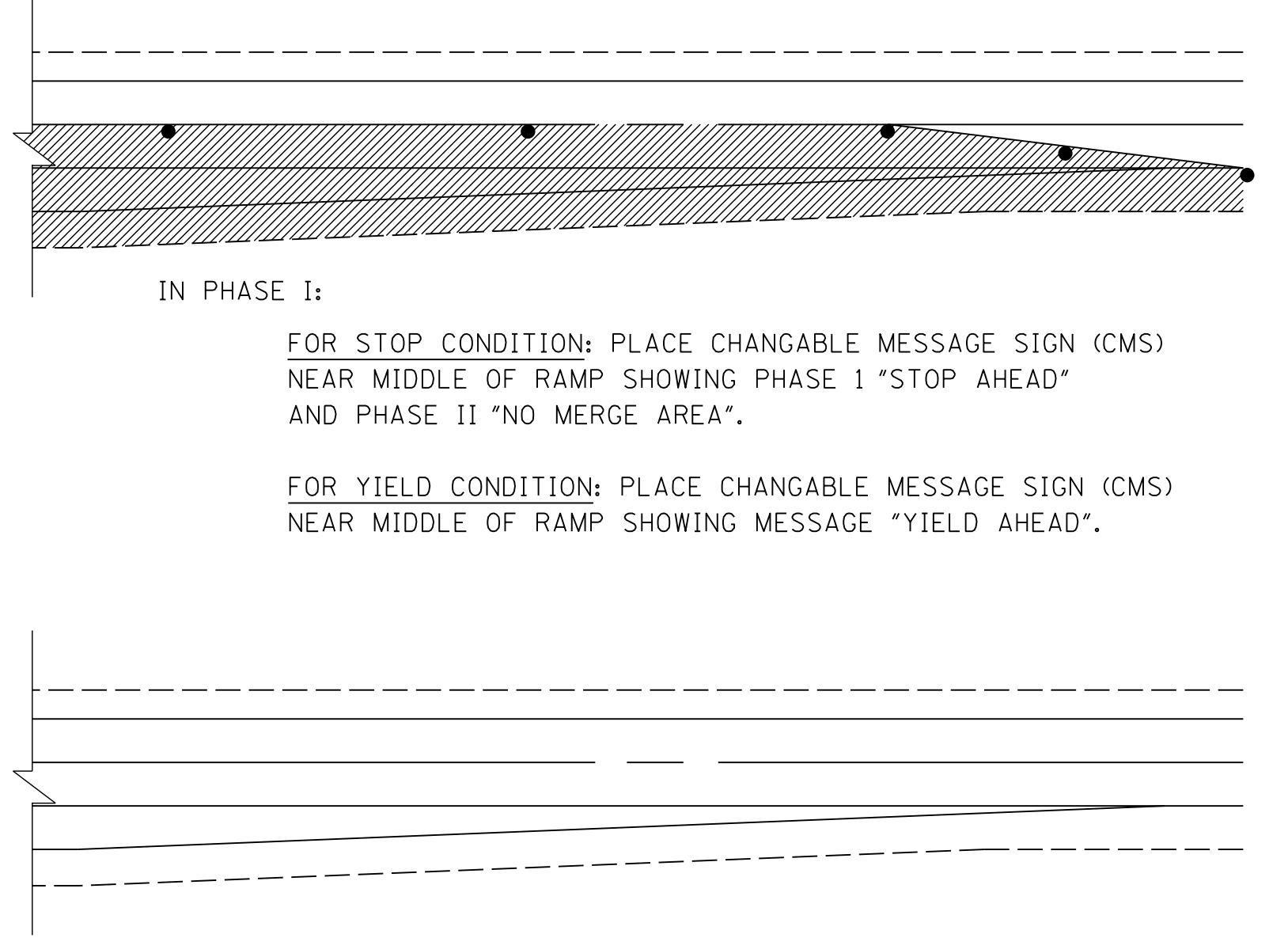
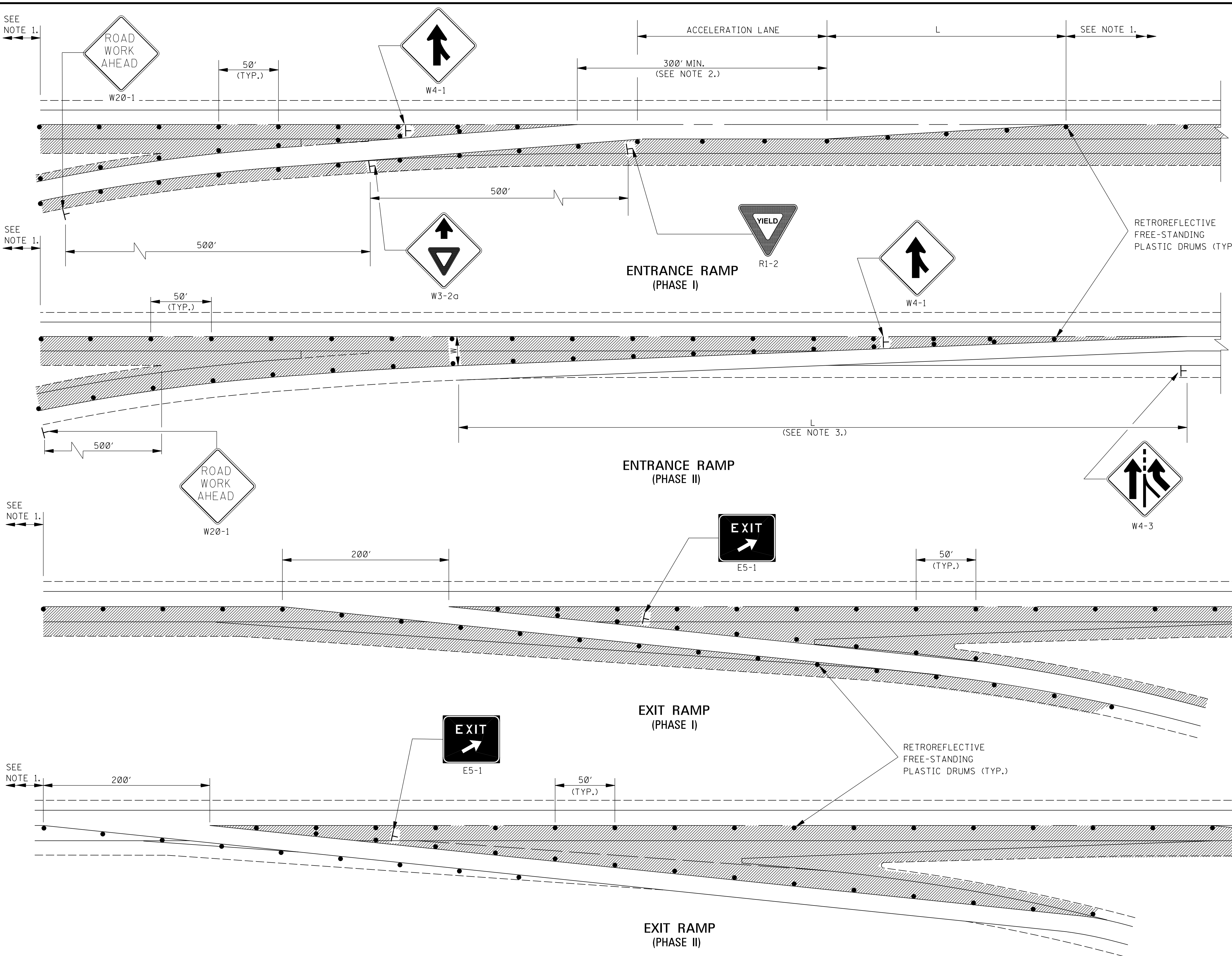

IN PHASE I:
 FOR STOP CONDITION: PLACE CHANGABLE MESSAGE SIGN (CMS) NEAR MIDDLE OF RAMP SHOWING PHASE I "STOP AHEAD" AND PHASE II "NO MERGE AREA".
 FOR YIELD CONDITION: PLACE CHANGABLE MESSAGE SIGN (CMS) NEAR MIDDLE OF RAMP SHOWING MESSAGE "YIELD AHEAD".

- GENERAL NOTES:
1. FOR SIGNING, FLASHING ARROW PANEL, AND DRUM SPACING CRITERIA, SEE TYPICAL TRAFFIC CONTROL PLANS FOR LANE CLOSURES ON SHEETS TCP-2, TCP-3, TCP-4, AND TCP-5, AS APPROPRIATE
 2. IF NO ACCELERATION LANE EXISTS FOR THE TEMPORARY ENTRANCE, THE YIELD SIGN (R1-2) AND THE YIELD AHEAD SIGN (W3-2A) SHALL BE REPLACED WITH A STOP SIGN (R1-1) AND A STOP AHEAD SIGN (W3-1a), ONE ON EACH SIDE OF APPROACH. WHERE STOP SIGNS ARE USED, A TEMPORARY STOP LINE SHOULD BE PLACED ACROSS THE RAMP AT THE DESIRED STOP LOCATION. IF INSUFFICIENT GAPS ARE AVAILABLE IN THE TRAFFIC STREAM, CONSIDERATION SHOULD BE GIVEN TO CLOSING THE RAMP.
 3. DETERMINE TAPER LAYOUTS USING THE FOLLOWING EQUATIONS:
 $L = WS$ FOR SPEED OF 45 mph OR GREATER
 $L = WS^2/60$ FOR SPEEDS OF 40 mph OR LESS
 WHERE:
 L = MINIMUM LENGTH OF TAPER IN FEET
 W = WIDTH OF OFFSET IN FEET
 S = DESIGN SPEED OR 85TH PERCENTILE SPEED IN MILES PER HOUR
 4. ALL TRAFFIC CONTROL ITEMS SHOWN ON THIS SHEET WILL NOT BE MEASURED FOR SEPARATE PAYMENT. THIS WORK SHALL BE INCLUDED IN THE PRICE BID FOR MAINTENANCE OF TRAFFIC.

BY		MISSISSIPPI DEPARTMENT OF TRANSPORTATION ROADWAY DESIGN DIVISION STANDARD PLAN	
REVISION		DETAILS OF OUTSIDE LANE CLOSURE AT EXIT AND ENTRANCE RAMP	
DATE		ISSUE DATE: AUGUST 01, 2017	
		 WORKING NUMBER TCP-10 SHEET NUMBER 6360	

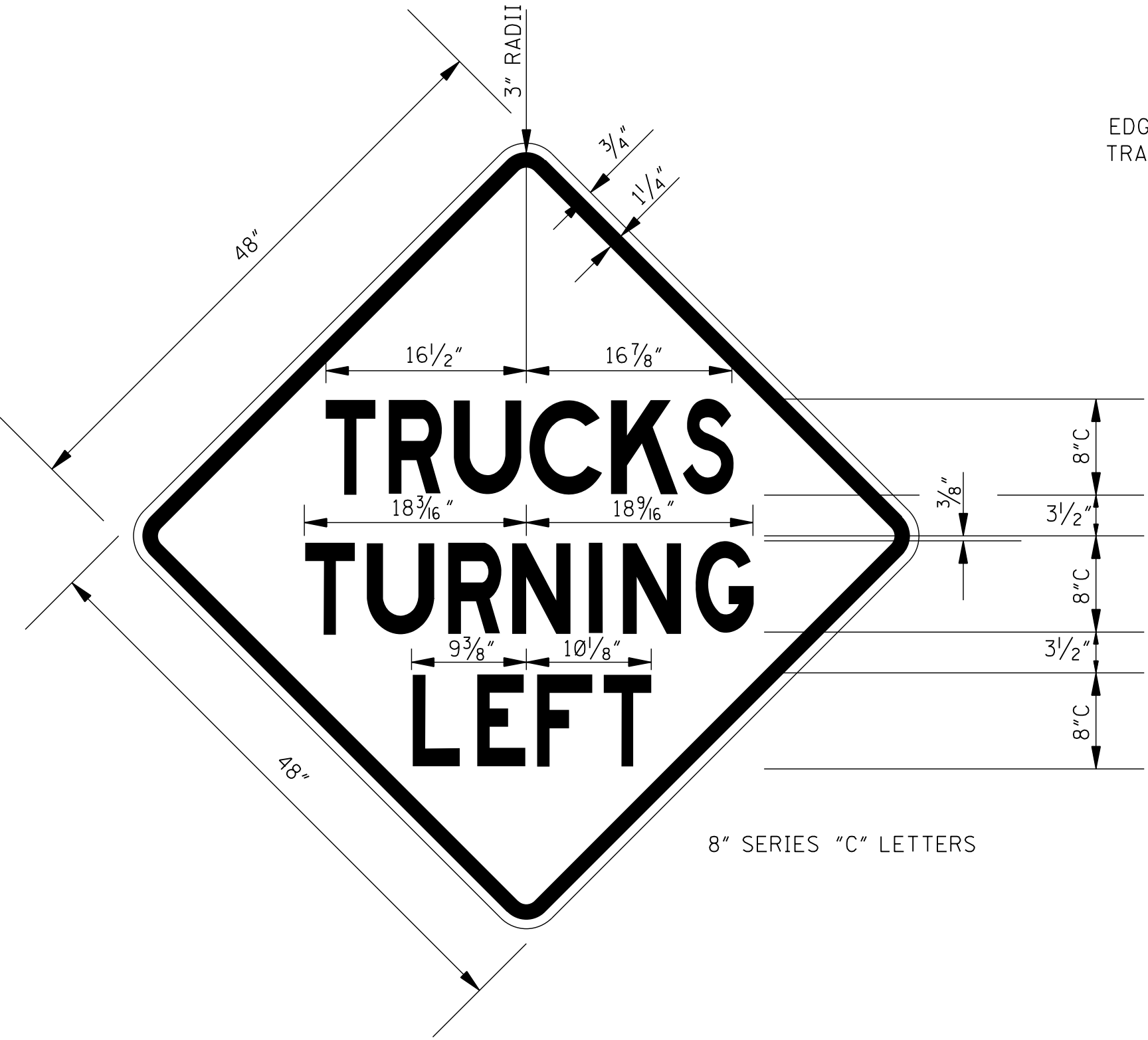
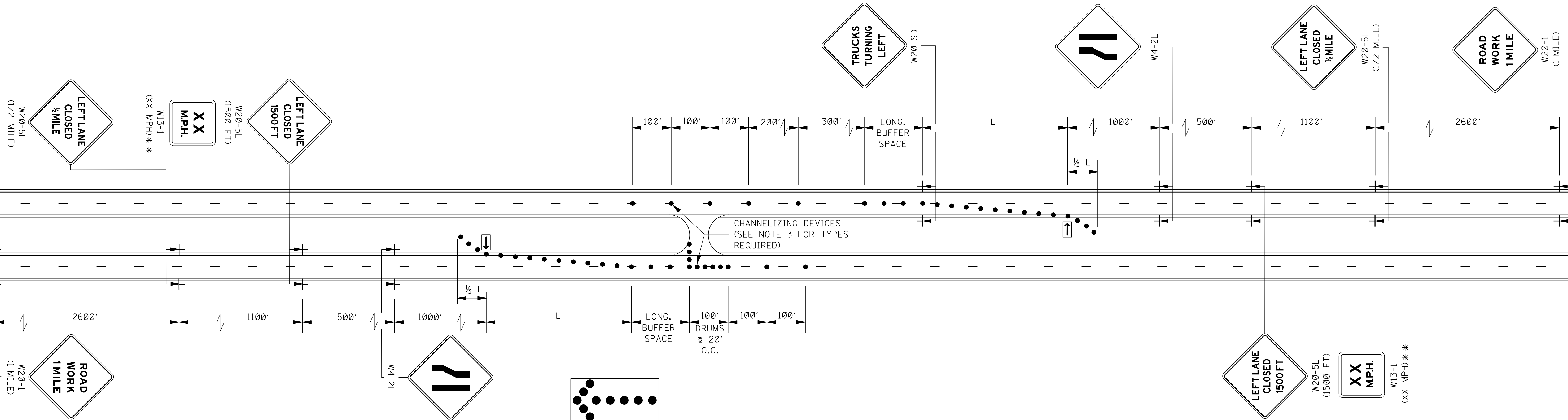

DETAIL OF W20-SD

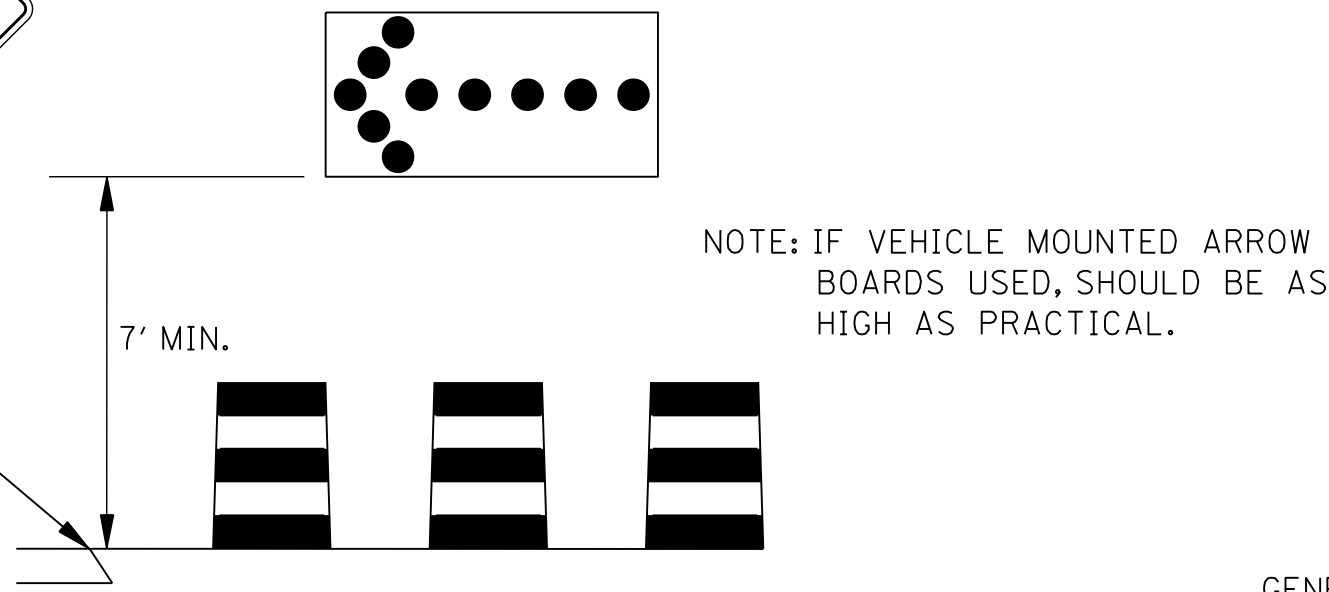

- LEGEND**
- ** THE SPEED ON W13-1 SIGN SHALL BE 10 MPH LESS THAN THE POSTED SPEED LIMIT UNLESS OTHERWISE DIRECTED BY COMMISSION ORDER.
 - ☒ FLASHING ARROW PANEL (TYPE "C")
 - RETROREFLECTIVE FREE-STANDING PLASTIC DRUMS
 - ☼ TYPE "B" WARNING LIGHTS

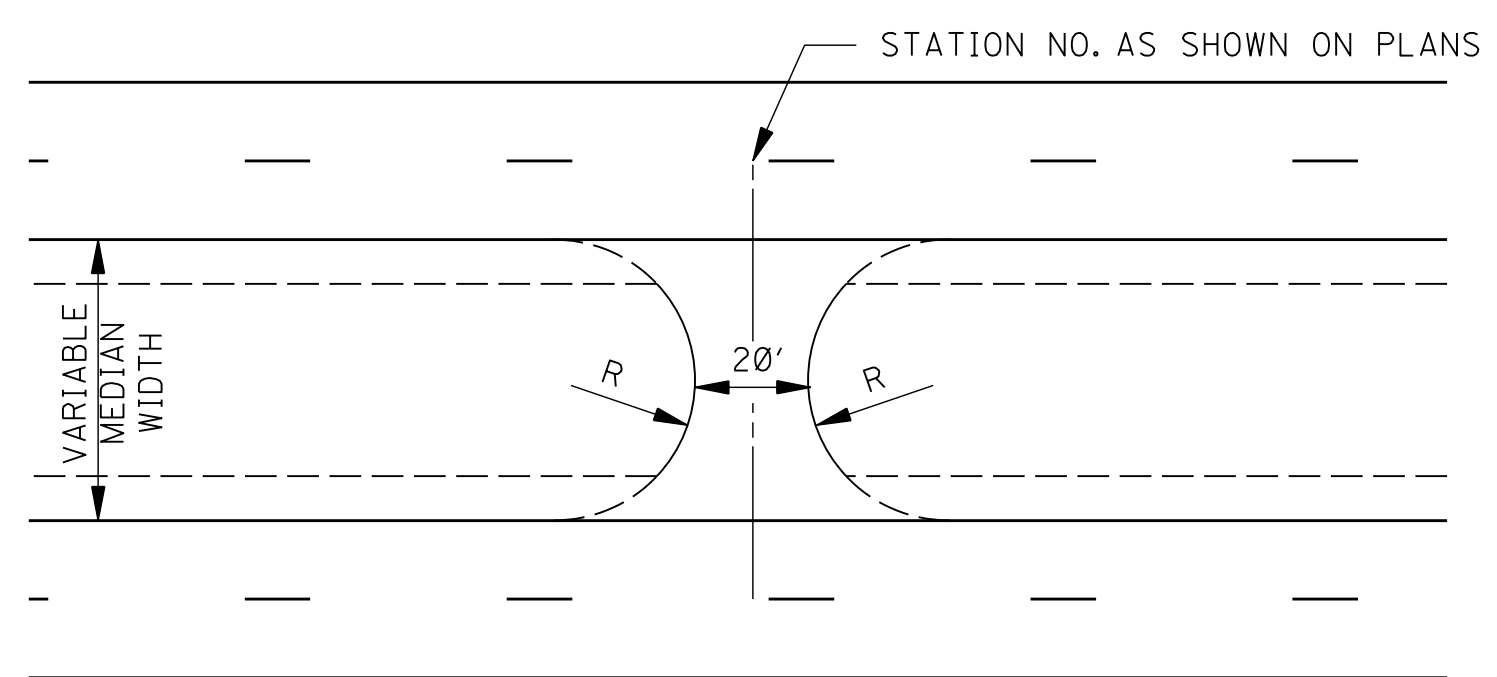

DETAIL OF TEMPORARY CROSSOVER
NOTE: R = 0.5 (MEDIAN WIDTH)

GENERAL NOTES:

1. THE LOCATION OF CHANNELIZING DEVICES AND THE WORK AREA LAYOUT SHALL BE BASED ON THE CRITERIA IN THE FOLLOWING TABLE:

POSTED SPEED AND/OR DESIGN SPEED	MAXIMUM CHANNELIZING DEVICE SPACING (ft)		LONGITUDINAL BUFFER SPACE (ft) ⁺⁺	TAPER [†] RATES
	TAPER	ALONG LANE LINE & WORK ZONE		
≤40	40	80	305	27:1
45	45	90	360	45:1
50	50	100	425	50:1
55	55	110	495	55:1
60	60	120	570	60:1
65	65	130	645	65:1
70	70	140	730	70:1

[†] NOTE: TAPER RATES ARE DETERMINED USING THE FOLLOWING EQUATIONS:
 $L = WS$ FOR SPEEDS OF 45 mph OR GREATER
 $L = WS^2/60$ FOR SPEEDS OF 40 mph OR LESS
 WHERE: L = MINIMUM LENGTH OF TAPER IN FEET
 W = WIDTH OF OFFSET (USUALLY LANE WIDTH) IN FEET
 S = DESIGN SPEED OR 85TH PERCENTILE SPEED IN MILES PER HOUR

⁺⁺ NOTE: BUFFER SPACE MAY BE ADJUSTED AS NEEDED ACCORDING TO ROADWAY GEOMETRY TO MEET SIGHT DISTANCE REQUIREMENTS, AS DIRECTED BY THE ENGINEER.

2. FLASHING ARROW PANEL SHOULD BE AS LEVEL AS POSSIBLE AS APPROVED BY THE ENGINEER. FLASHING ARROW PANEL SHOULD BE LOCATED AT THE BEGINNING OF THE TAPER OR, IF THE SHOULDER IS TOO NARROW, BEHIND THE CHANNELIZING DEVICES IN THE CLOSED LANE.
3. ALL CHANNELIZING DEVICES SHALL BE RETROREFLECTIVE FREE STANDING PLASTIC DRUMS.
4. DIAMOND SHAPED TRAFFIC CONTROL SIGNS SHOULD BE A MINIMUM OF 48" X 48" AND SHALL BE BLACK COPY ON FLUORESCENT ORANGE SHEETING.
5. LOCATION OF CROSSOVERS WILL BE AS SHOWN ON THE PLANS OR AS DIRECTED BY THE ENGINEER.
6. USE OF CROSSOVER SHALL BE LIMITED TO TRUCKS APPROACHING FROM ONE DIRECTION ONLY.
7. REVERSE LAYOUT OF TAPERS, DRUMS AND SIGNS TO ACCOMMODATE TRUCKS APPROACHING FROM OPPOSITE DIRECTION.
8. EACH CONSTRUCTION CROSSOVER SHOULD BE CLOSED AS DIRECTED BY THE ENGINEER OR WHEN THE CONSTRUCTION OPERATION, ZONE OR SIGNS ENCROACH ON OR INTERFERES WITH THE OPERATION OF THE CONSTRUCTION CROSSOVER. THE CROSSOVER SHOULD BE CLOSED USING 24' OF TYPE III BARRICADE (DOUBLE FACED).
9. ALL TRAFFIC CONTROL ITEMS SHOWN ON THIS SHEET WILL NOT BE MEASURED FOR SEPARATE PAYMENT. THIS WORK SHALL BE INCLUDED IN THE PRICE BID FOR MAINTENANCE OF TRAFFIC.

BY		MISSISSIPPI DEPARTMENT OF TRANSPORTATION ROADWAY DESIGN DIVISION STANDARD PLAN	
REVISION		TRAFFIC CONTROL PLAN FOR TEMPORARY CONSTRUCTION CROSSOVER (WORK DAY ONLY)	
DATE		ISSUE DATE: AUGUST 01, 2017	
		 WORKING NUMBER TCP-11 SHEET NUMBER 6361	

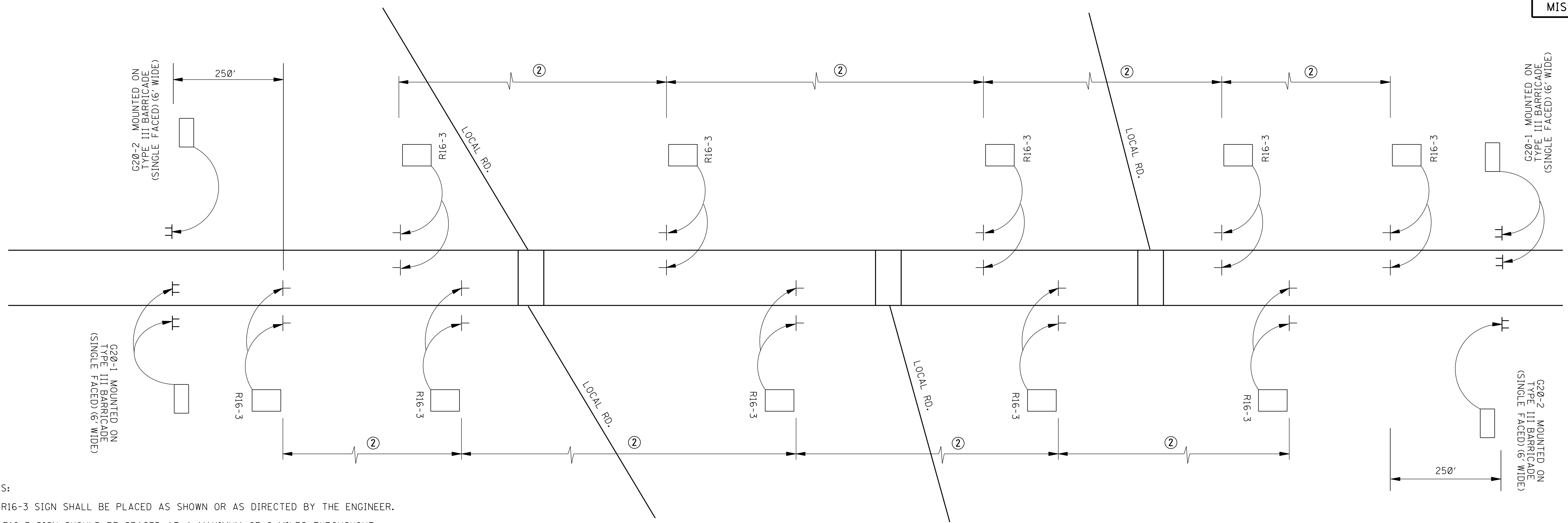

NOTES:

1. R16-3 SIGN SHALL BE PLACED AS SHOWN OR AS DIRECTED BY THE ENGINEER.
2. R16-3 SIGN SHOULD BE SPACED AT A MAXIMUM OF 2 MILES THROUGHOUT LENGTH OF PROJECT.
3. THIS SHEET WILL ONLY APPLY TO SPEED REDUCTION SECTIONS.

**DIVIDED HIGHWAY SHOWN
(2 LANE – 2 WAY ROADWAY SIMILAR)
(PROJECT MORE THAN 1 MILE LENGTH)**

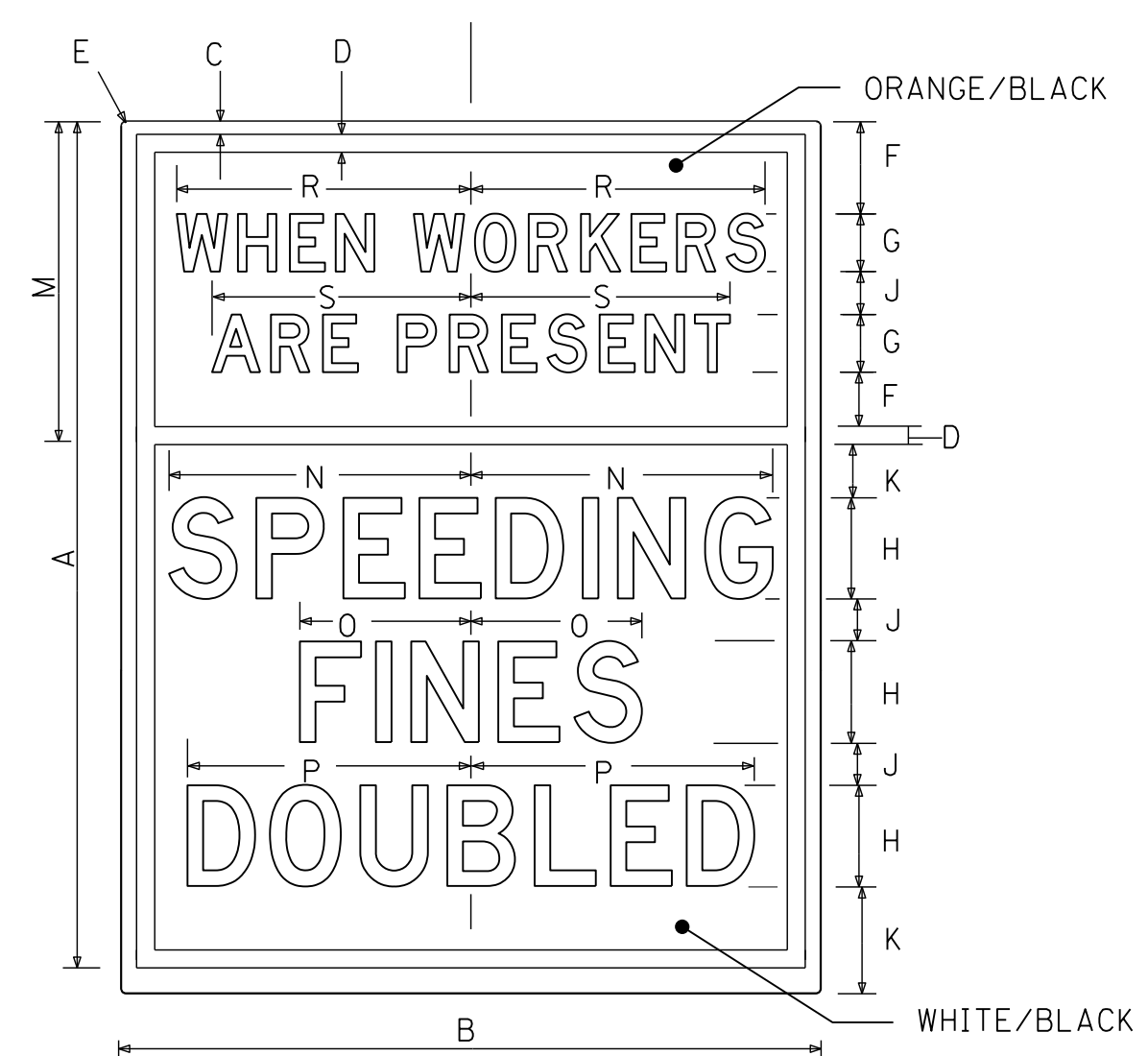

SIGN	DIMENSIONS (INCHES)							
	A	B	C	D	E	F	G	H
STD.	60	48	3/4	1 1/4	3	3 3/4	4 Dm	7 D
STD.	3	6 5/8	22 1/8	21	11 1/8	19 2 1/2	20 5/32	18

**48" x 60"
(INTERSTATE USE)**

SIGN	DIMENSIONS (INCHES)							
	A	B	C	D	E	F	G	H
STD.	48	36	3/4	1 1/4	3	2 3/4	3 Dm	6 D
STD.	3	4 1/8	14 3/4	14	7 1/8	13 1/8	13 5/8	12

**36" x 48"
(ALL OTHER HIGHWAYS)**

R16-3

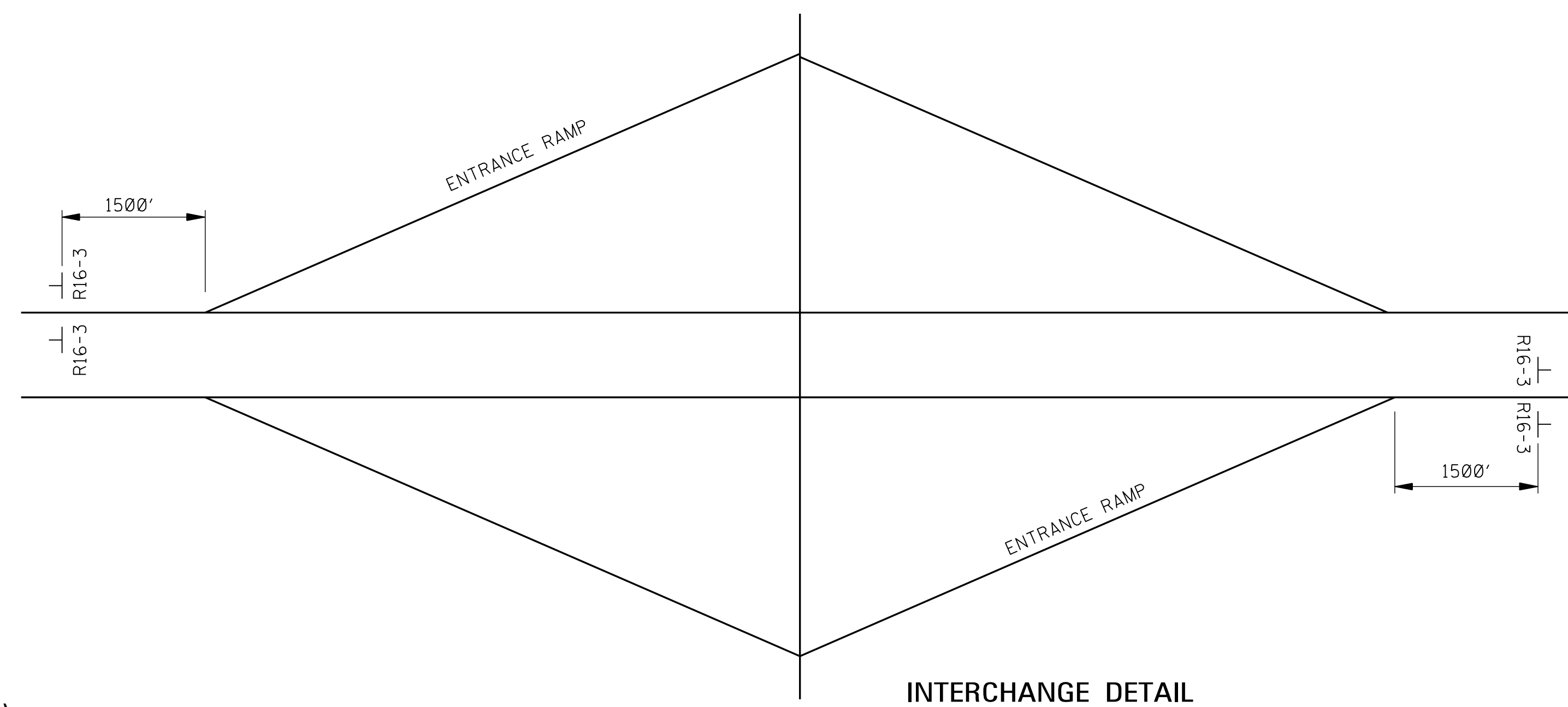

INTERCHANGE DETAIL

BY	MISSISSIPPI DEPARTMENT OF TRANSPORTATION ROADWAY DESIGN DIVISION STANDARD PLAN
REVISION	
DATE	ISSUE DATE: AUGUST 01, 2017

**LOCATION OF
R16-3 SIGNS
(SPEEDING FINES
DOUBLED)**

MDOT
MISSISSIPPI DEPARTMENT OF TRANSPORTATION
WORKING NUMBER
TCP-15
SHEET NUMBER
6365

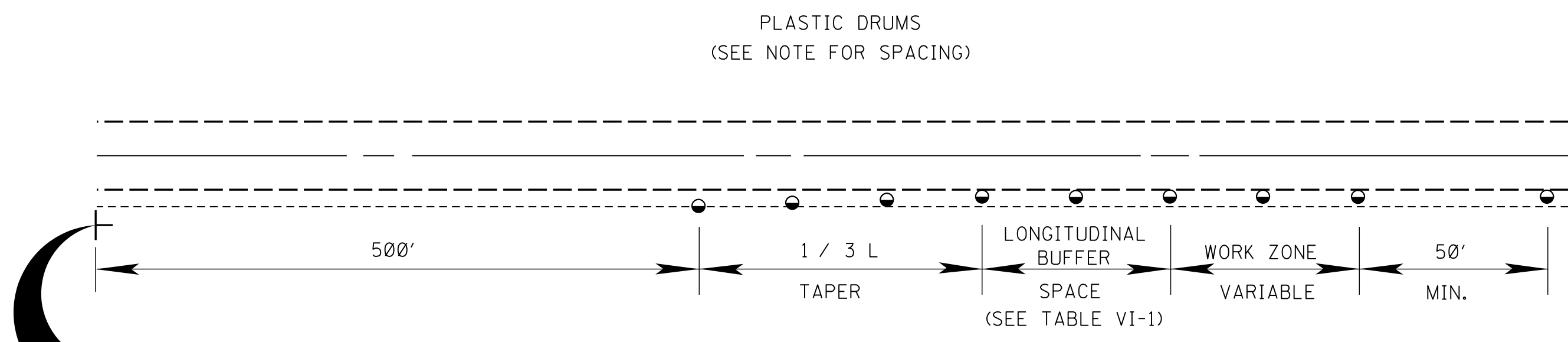

TYPICAL SHOULDER CLOSURE

- (1) TO BE USED WITH EIGHT (8) FOOT OR GREATER WIDTH IMPROVED SHOULDER.
- (2) TO BE USED WHEN CONSTRUCTION VEHICLES (EQUIPMENT) ENCROACHES ON OR WITHIN TWO (2) FEET OF THE SHOULDER BREAK.

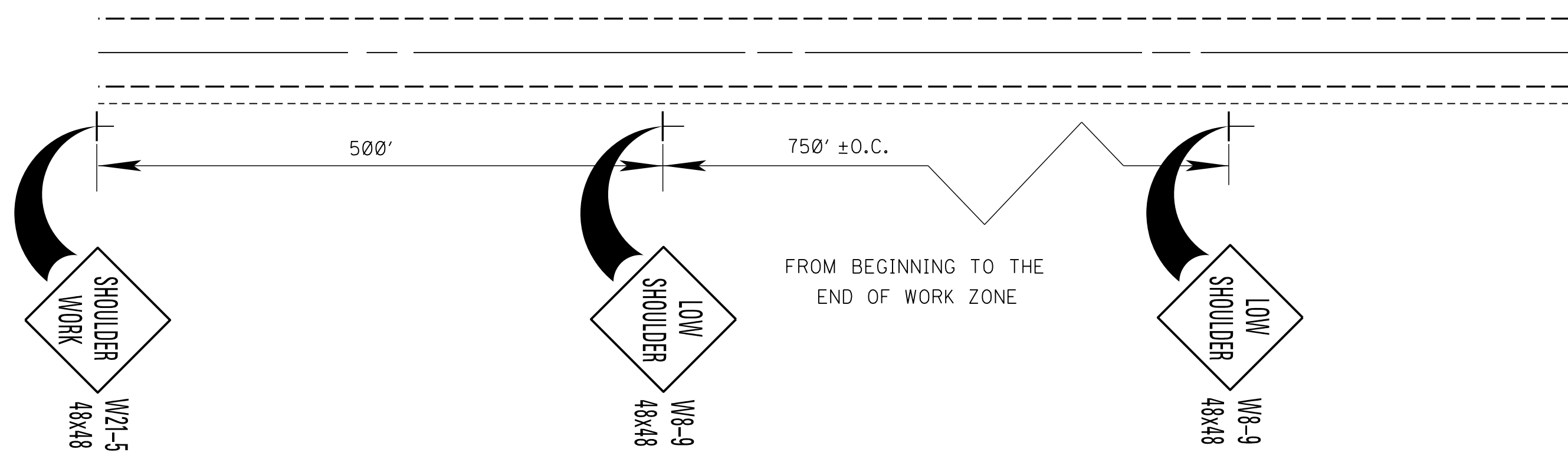
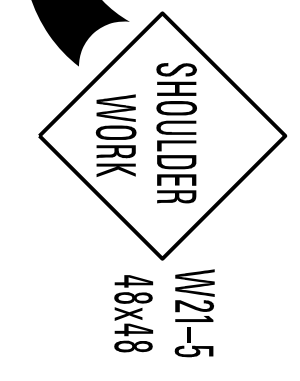

**TYPICAL SHOULDER WORK #1
(SEE NOTE A-1 THIS SHEET)**

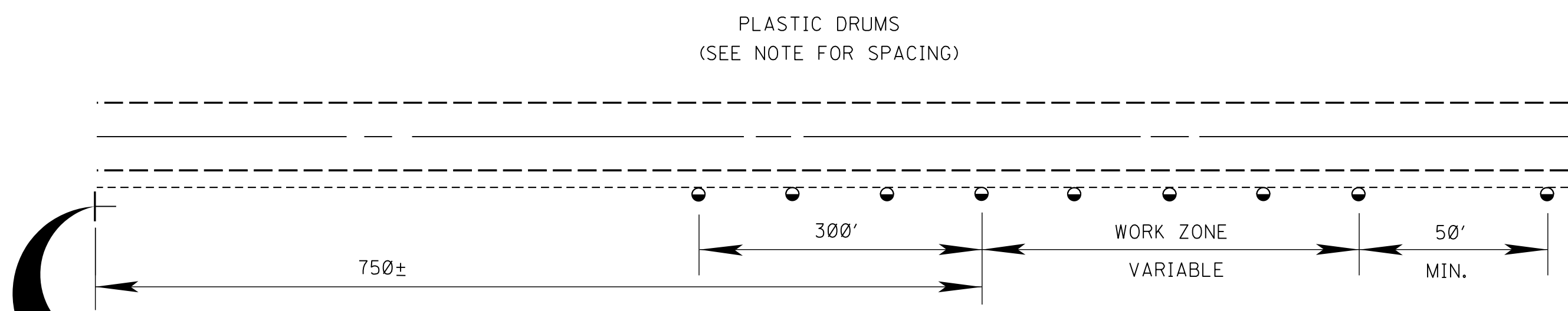
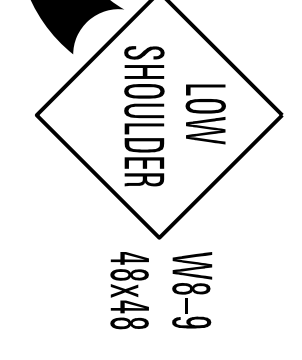
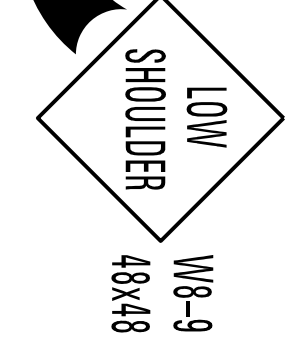

TYPICAL SHOULDER WORK #2

NOTE:
WORK OUTSIDE TWO (2) FOOT AND WITHIN TEN (10) FEET OF THE SHOULDER BREAK MAY BE PROTECTED BY PLACING DRUMS ALONG THE SHOULDER EDGE, 300 FEET PRIOR TO AND 50 FEET BEYOND THE WORK AREA, OR SEE NOTE A-3 THIS SHEET.

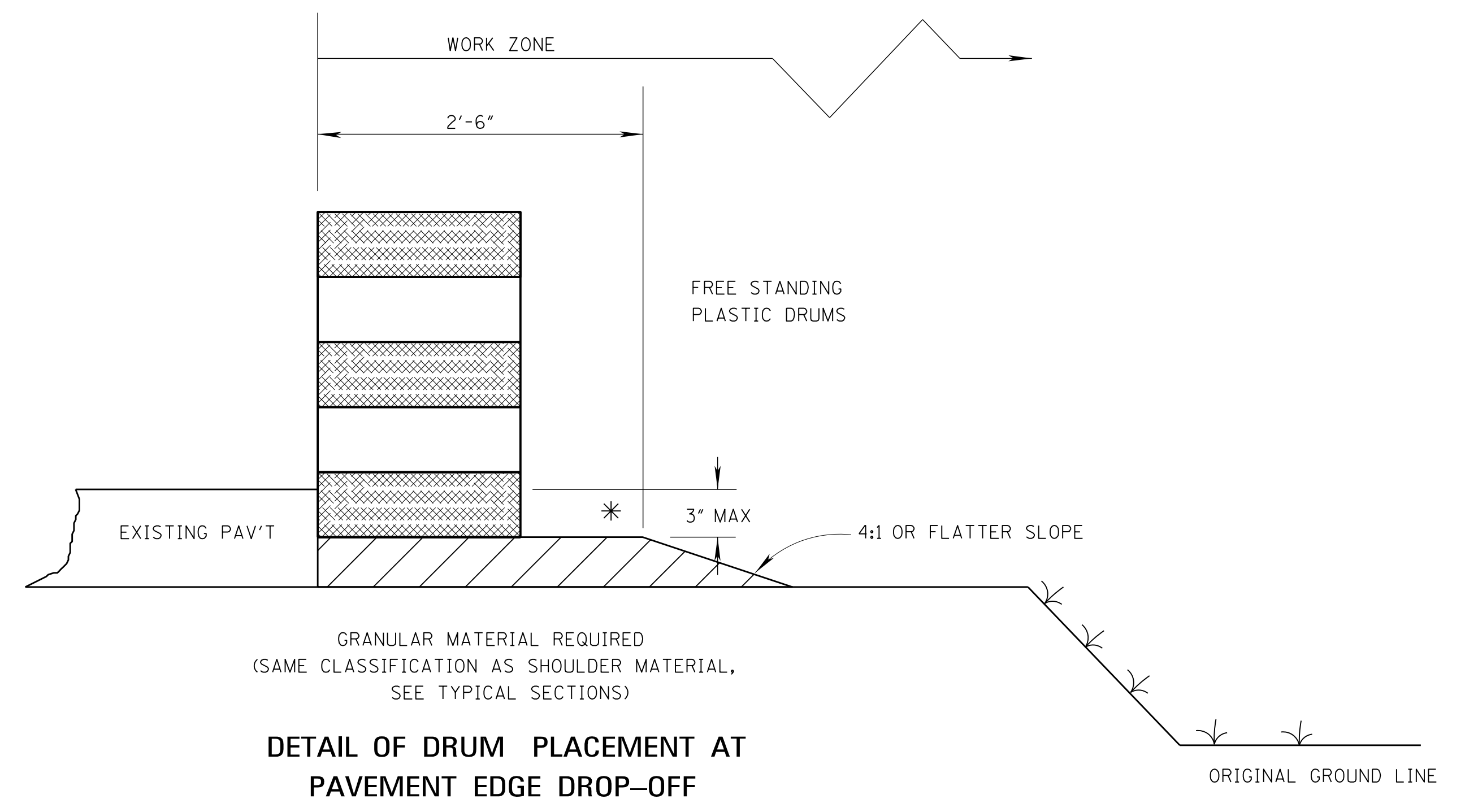
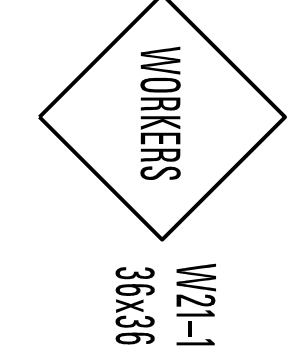

DETAIL OF DRUM PLACEMENT AT PAVEMENT EDGE DROP-OFF

NOTES:

- * A. PAVEMENT EDGE DROP-OFF
 1. IF LESS THAN TWO AND ONE QUARTER (2.25) INCHES-NO PROTECTION REQUIRED. PLACE A SHOULDER WORK SIGN (W21-5) 500 FEET IN ADVANCE OF WORK ZONE SHOULDER AND A LOW SHOULDER SIGN (W8-9) AT THE BEGINNING AND THROUGHOUT THE WORK ZONE @ (750'±O.C.).
 2. TWO AND ONE QUARTER TO THREE INCHES-PLACE DRUMS, VERTICAL PANELS OR BARRICADES EVERY 100 FEET ON TANGENT SECTIONS FOR SPEEDS OF 50 MILES PER HOUR OR GREATER. CONES MAY BE USED IN PLACE OF DRUMS, PANELS, AND BARRICADES DURING DAYLIGHT HOURS. FOR TANGENT SECTIONS WITH SPEEDS LESS THAN 50 MILES PER HOUR AND FOR CURVES, DEVICES SHOULD BE PLACED EVERY 50 FEET. SPACING FOR TAPERS SHOULD BE IN ACCORDANCE WITH THE M.U.T.C.D. (1 / 3 L, WHERE L IS THE TAPER LENGTH IN FEET.)
 3. GREATER THAN THREE (3) INCHES-POSITIVE SEPARATION OR WEDGE WITH 4:1 OR FLATTER SLOPE NEEDED. IF THERE IS EIGHT (8) FEET OR MORE DISTANCE BETWEEN THE EDGE OF TRAVEL LANE AND DROP-OFF, THEN DRUMS, PANELS OR BARRICADES MAY BE USED.
 4. FOR TEMPORARY CONDITIONS, DROP-OFFS GREATER THAN THREE (3) INCHES MAY BE PROTECTED WITH DRUMS, VERTICAL PANELS OR BARRICADES FOR SHORT DISTANCES DURING DAYLIGHT HOURS WHILE WORK IS BEING DONE IN THE DROP-OFF AREA.
 5. LESSER TREATMENTS THAN THOSE DESCRIBED ABOVE MAY BE CONSIDERED FOR LOW-VOLUME LOCAL STREETS.
- B. DRUM SPACING
 1. TANGENTS = 2 X S
 2. TAPERS = L / 3

WHERE L = S X W
L = TAPER LENGTH IN FEET
S = SPEED IN MPH (POSTED OR 85 PERCENTILE)
W = WIDTH OF OFFSET IN FEET
- C. ALL TRAFFIC CONTROL ITEMS SHOWN ON THIS SHEET SHALL BE PAID FOR UNDER MAINTENANCE OF TRAFFIC.

TABLE VI-1. GUIDELINES FOR LENGTH OF LONGITUDINAL BUFFER SPACE

** SPEED (MPH)	LENGTH (FEET)
20	35
25	55
30	85
35	120
40	170
45	220
50	280
55	335
60	415
65	485

** POSTED SPEED, OFF-PEAK 85 PERCENTILE SPEED PRIOR TO WORK STARTING, OR THE ANTICIPATED OPERATING SPEED IN MPH.

MISSISSIPPI DEPARTMENT OF TRANSPORTATION ROADWAY DESIGN DIVISION STANDARD PLAN	
TRAFFIC CONTROL DETAILS DRUM PLACEMENT AND SHOULDER CLOSURE	
BY	
REVISION	
DATE	ISSUE DATE: AUGUST 01, 2017
WORKING NUMBER TCP-16 SHEET NUMBER 6366	

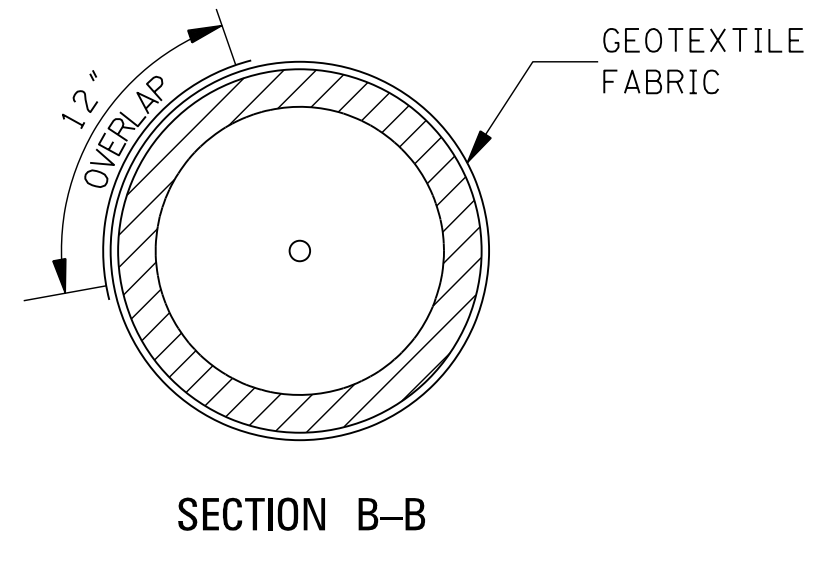
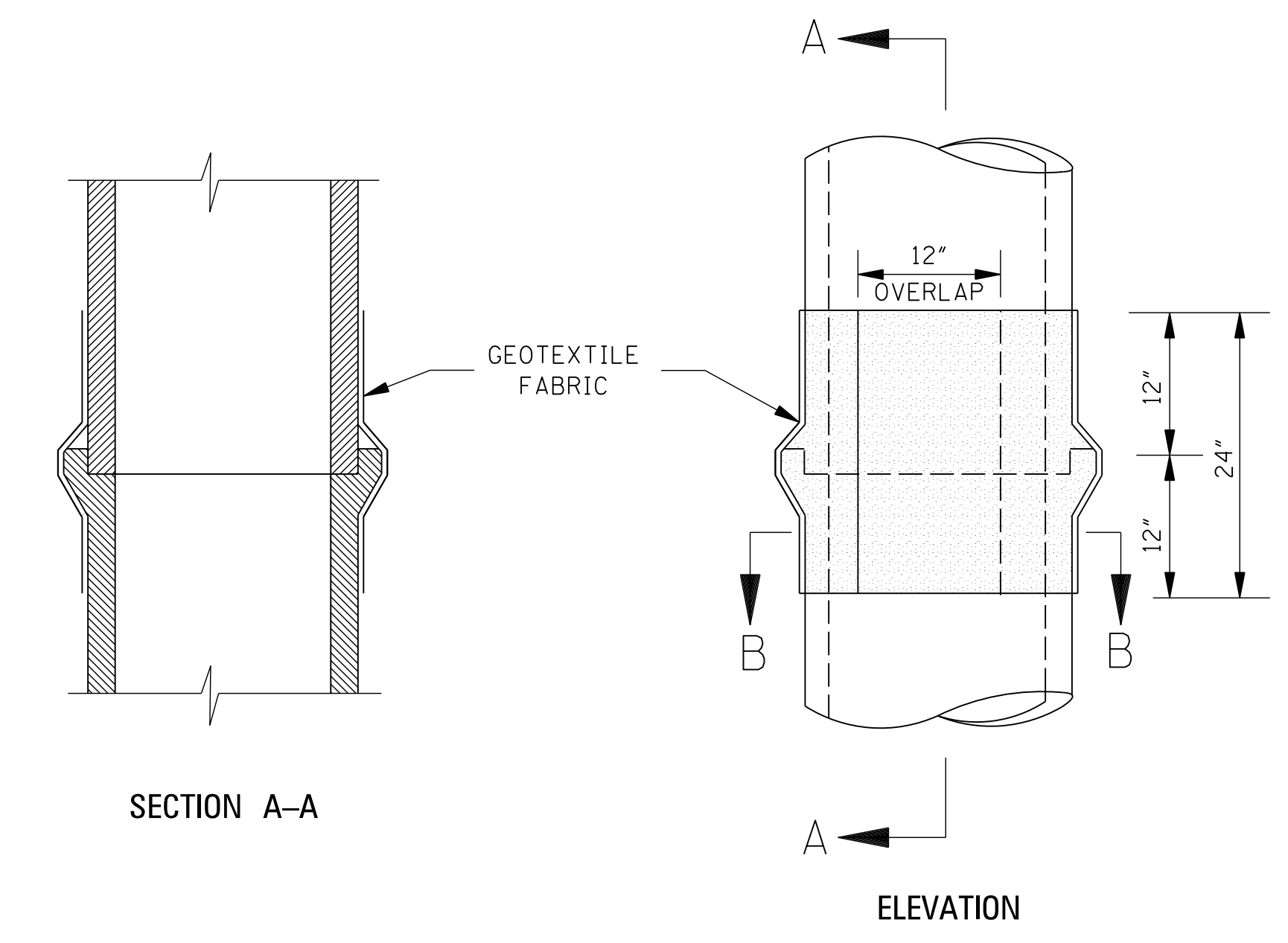

STACKED PIPE JOINTS

NOTE: EACH STACKED PIPE JOINT SHALL BE TREATED FIRST WITH A BITUMINOUS PLASTIC SEALER MATERIAL AND SECONDLY WRAPPED WITH 24" WIDE TYPE V GEOTEXTILE FABRIC (AASHTO M 288). THE FABRIC SHALL OVERLAP A MINIMUM OF 12" AT THE WRAP AND SHALL BE SECURED WITH STRING OR WIRE AS APPROVED BY THE ENGINEER PRIOR TO BACKFILLING. THE COST SHALL BE ABSORBED IN OTHER ITEMS BID.

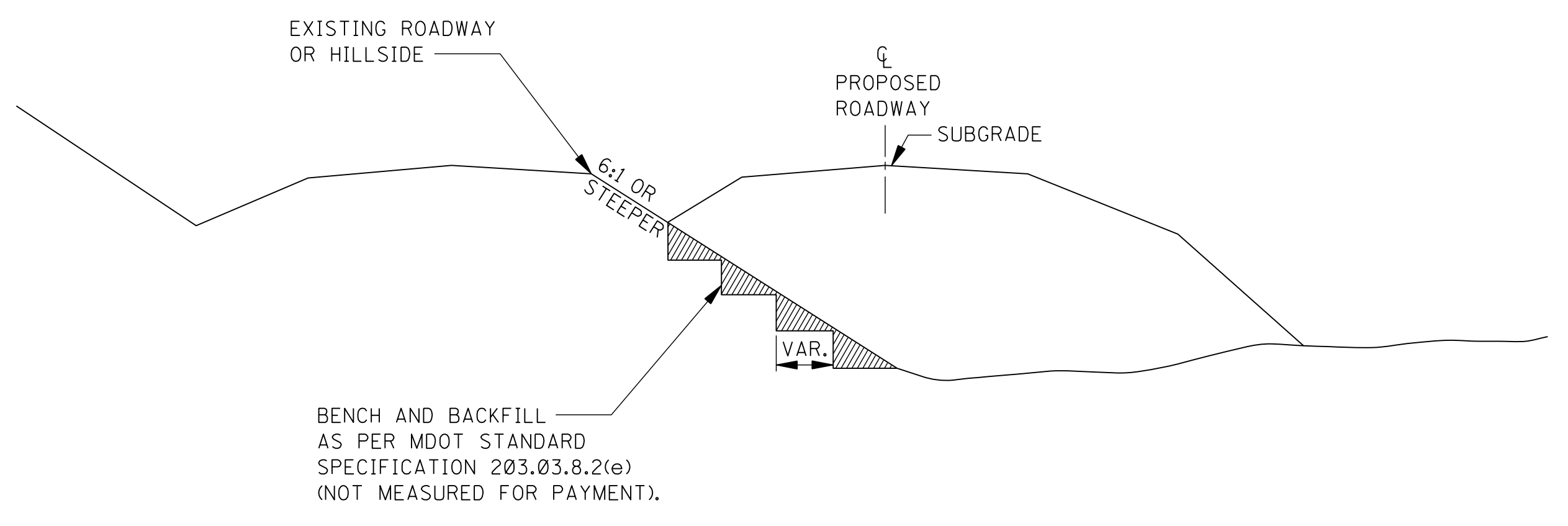
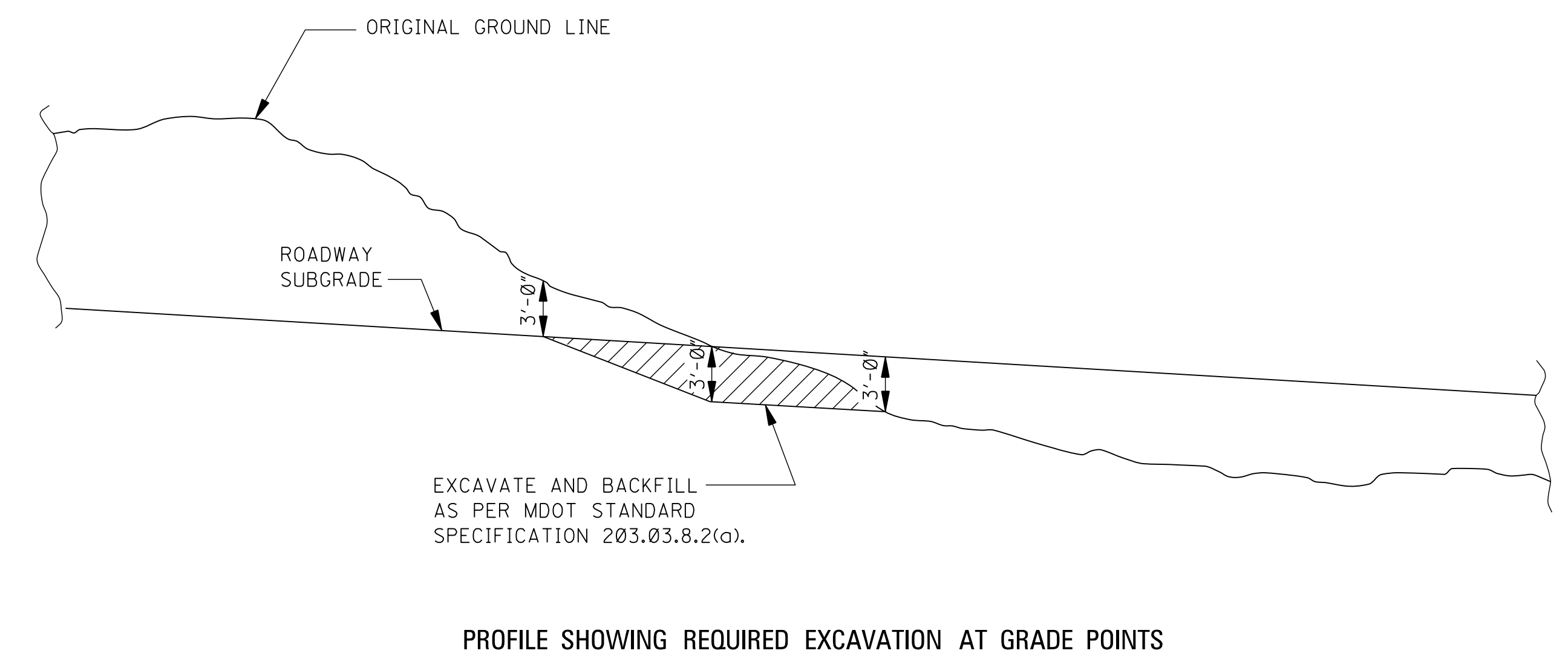

CROSS-SECTION SHOWING REQUIRED BENCHING UNDER EMBANKMENTS ON STEEP SLOPES

EXCAVATION AT GRADE POINTS

MISSISSIPPI DEPARTMENT OF TRANSPORTATION ROADWAY DESIGN DIVISION STANDARD PLAN	
MISCELLANEOUS DETAIL SHEET	
<ol style="list-style-type: none"> 1. STACKED PIPE JOINTS 2. EXCAVATION AT GRADE POINTS 	
DATE	ISSUE DATE: AUGUST 01, 2017
BY	
REVISION	
WORKING NUMBER	MDS-1
SHEET NUMBER	6425

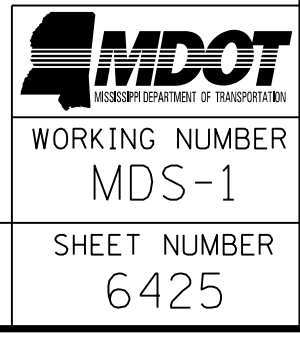

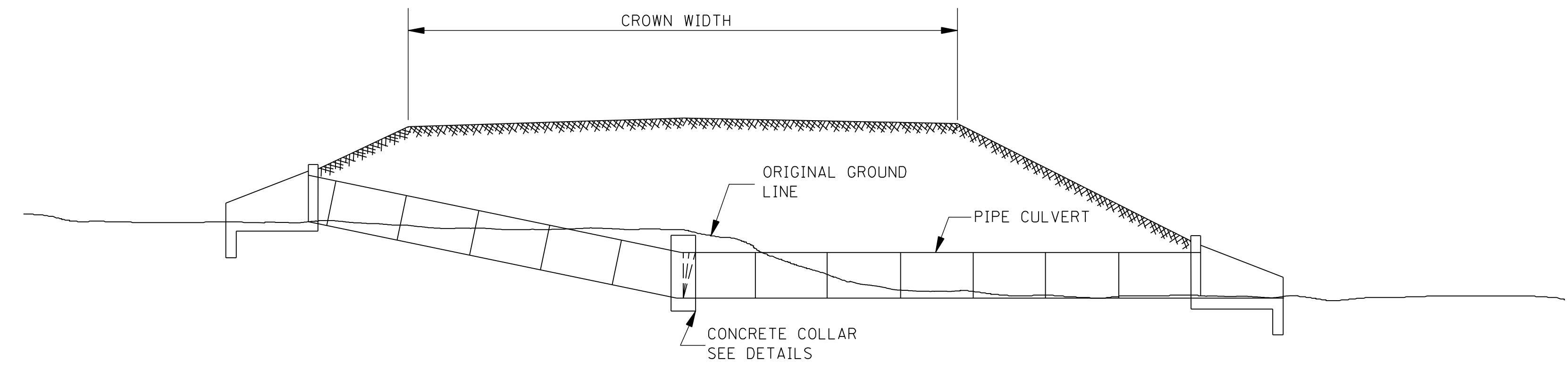

TYPICAL INSTALLATION FOR PIPE CULVERT WITH BROKEN FLOW LINE

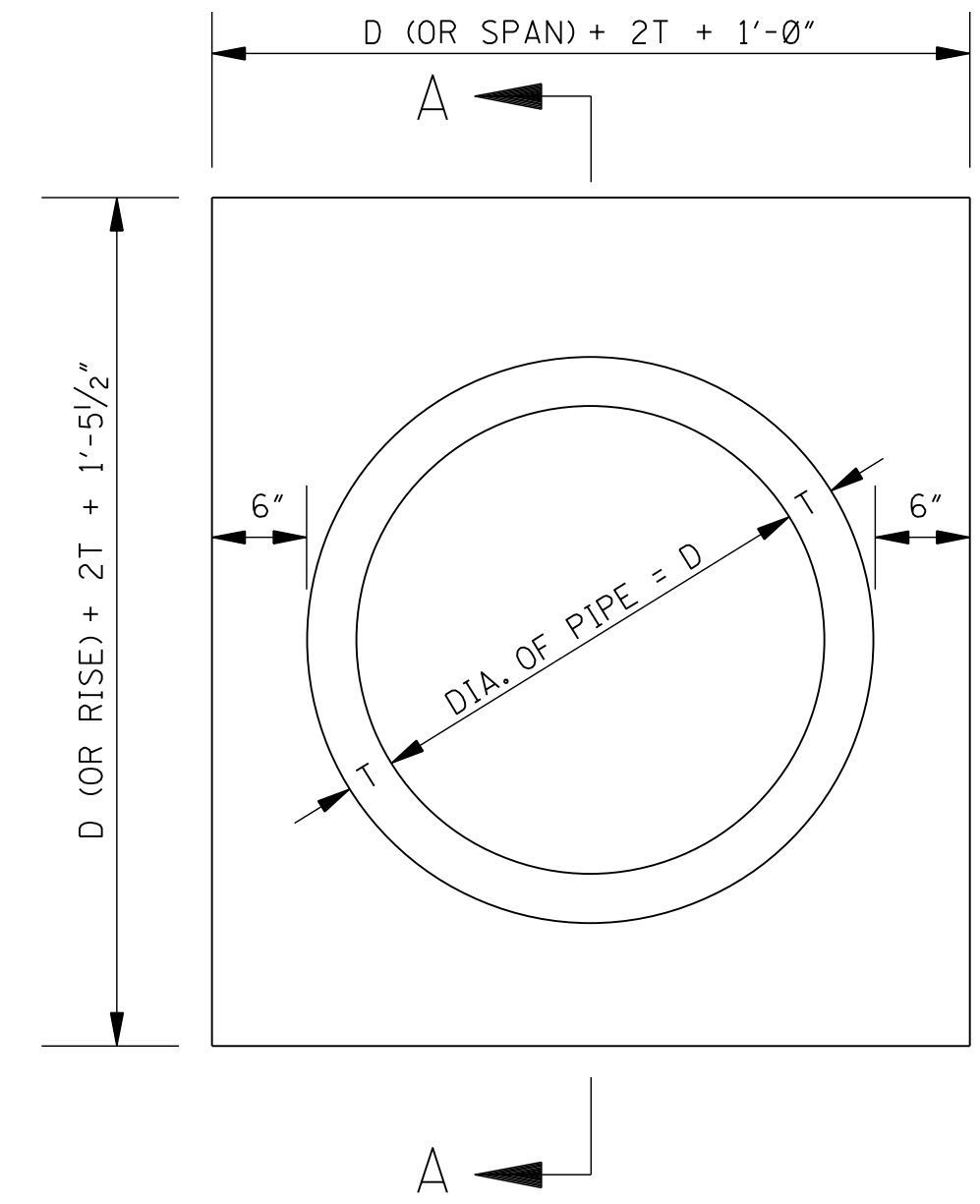

ELEVATION OF CONCRETE COLLAR
NOTE: CIRCULAR PIPE IS SHOWN, ARCH PIPE IS SIMILAR.

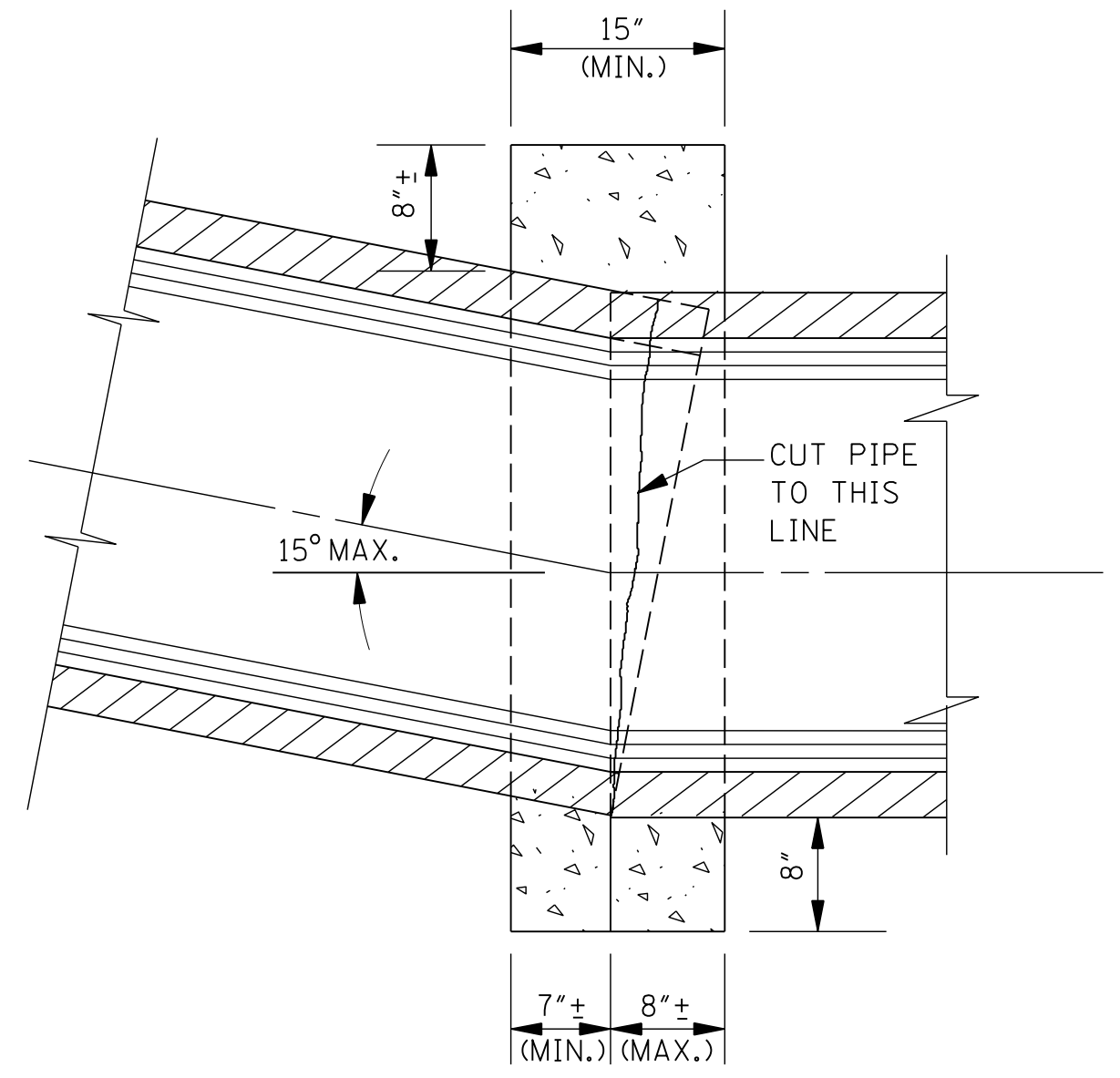

SECTION A-A

GENERAL NOTES:

1. THE MAXIMUM BEND ANGLE IS 15 DEGREES.
2. THE FOLLOWING QUANTITIES SHALL BE THE BASIS FOR PAYMENT UNLESS AUTHORIZED MODIFICATIONS ARE MADE:

QUANTITIES FOR CONCRETE COLLAR FOR PIPE CULVERTS			
CIRCULAR PIPE		ARCH PIPE	
DIA. OF PIPE	CLASS "B" CONCRETE (yd ³)	SIZE OF PIPE	CLASS "B" CONCRETE (yd ³)
12"	0.240		
15"	0.260	18 x 11	0.280
18"	0.320	22 x 13	0.310
24"	0.410	29 x 18	0.410
30"	0.510	36 x 23	0.490
36"	0.620	44 x 27	0.600
42"	0.730	51 x 31	0.690
48"	0.850	58 x 36	0.820
54"	0.980	65 x 40	0.920
60"	1.110	73 x 45	1.070
66"	1.248	88 x 54	1.366
72"	1.393		

BY	MISSISSIPPI DEPARTMENT OF TRANSPORTATION ROADWAY DESIGN DIVISION STANDARD PLAN
REVISION	CONCRETE PIPE COLLAR
DATE	ISSUE DATE: AUGUST 01, 2017

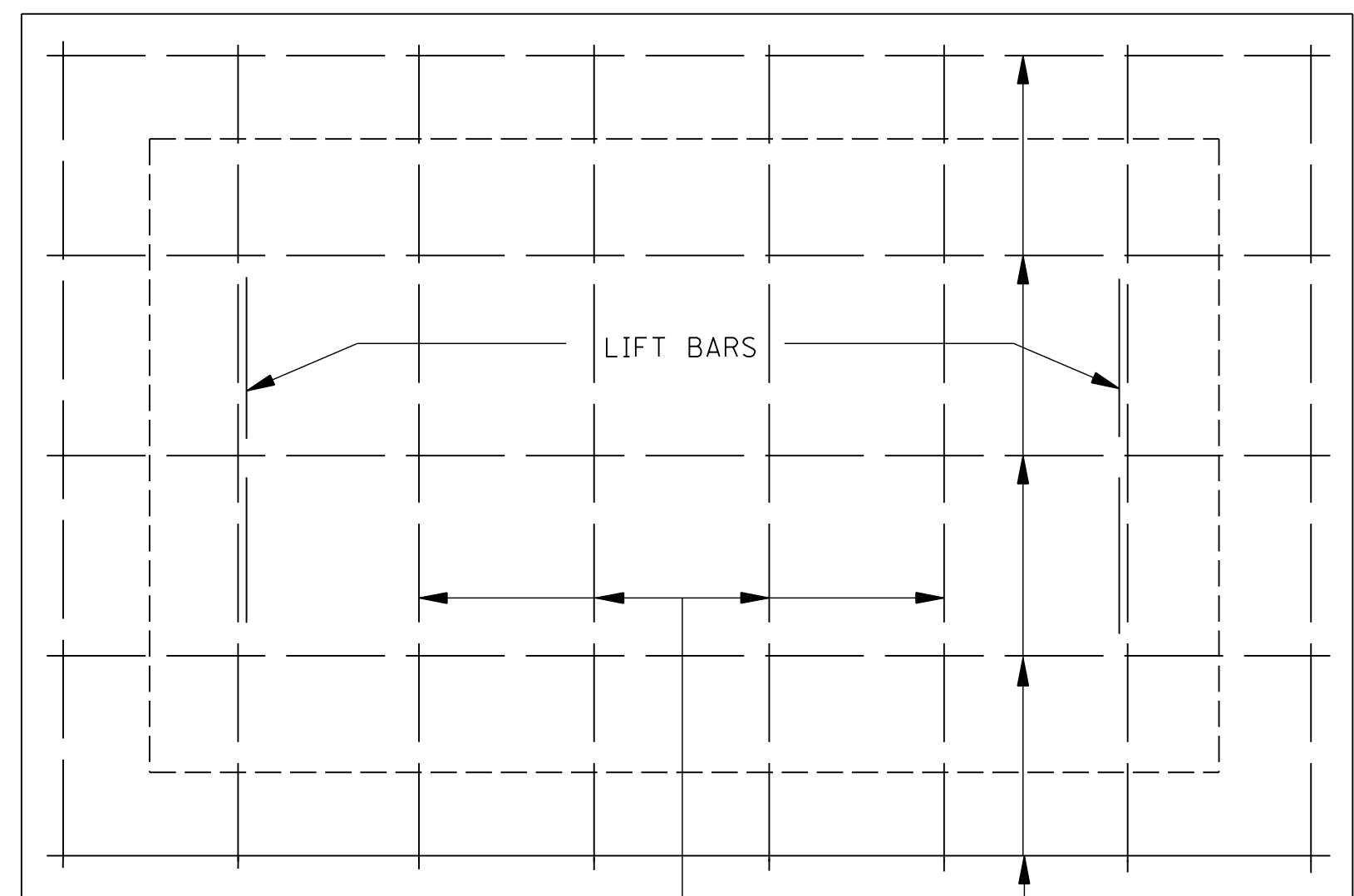

 WORKING NUMBER
 PC-1
 SHEET NUMBER
 6503

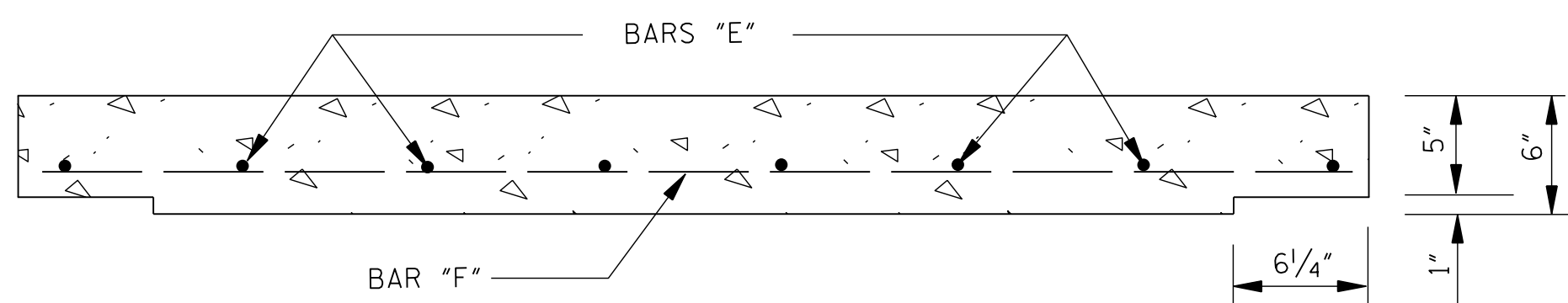

PLAN OF COVER

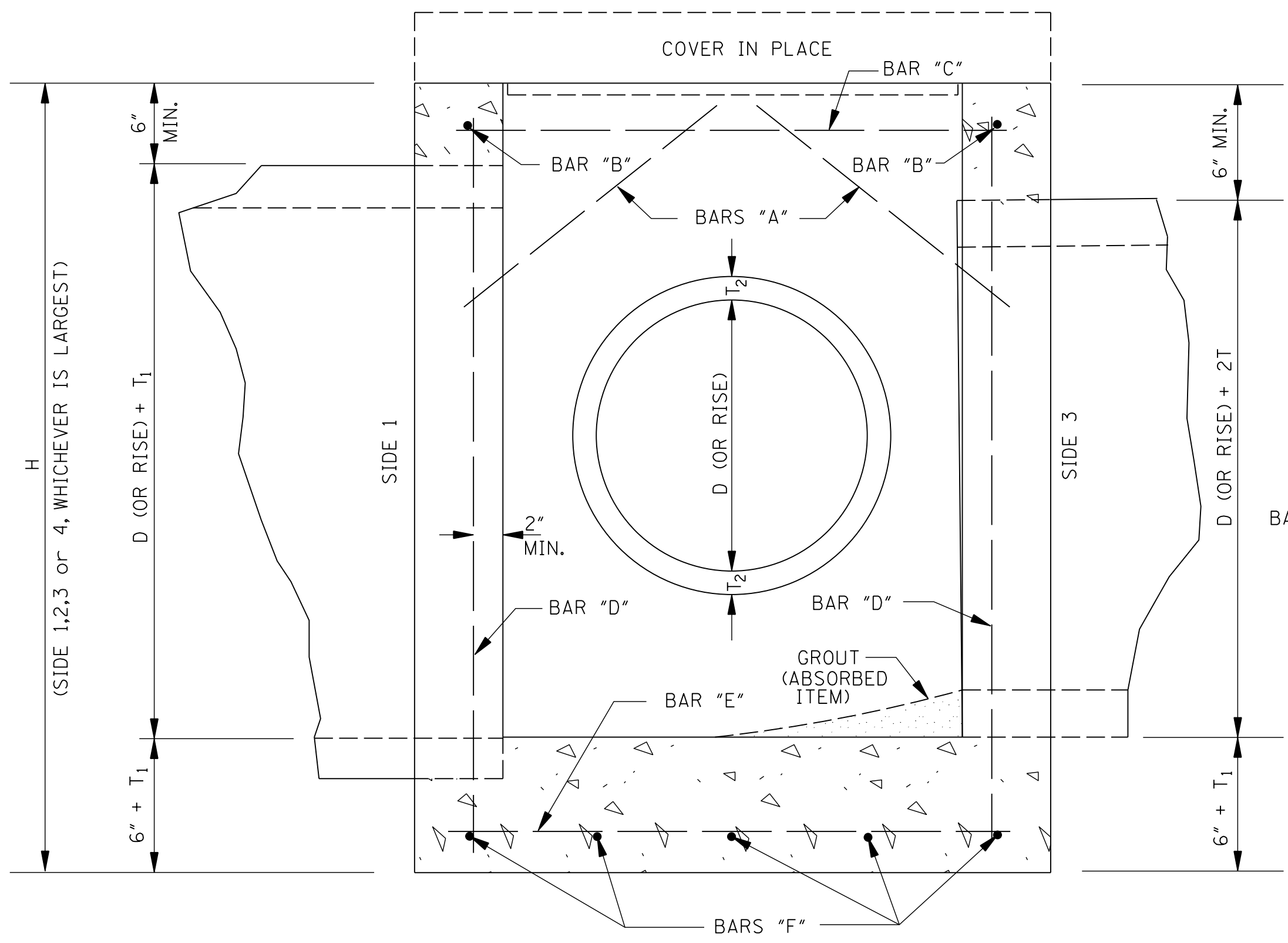

ELEVATION OF COVER



SECTION B-B

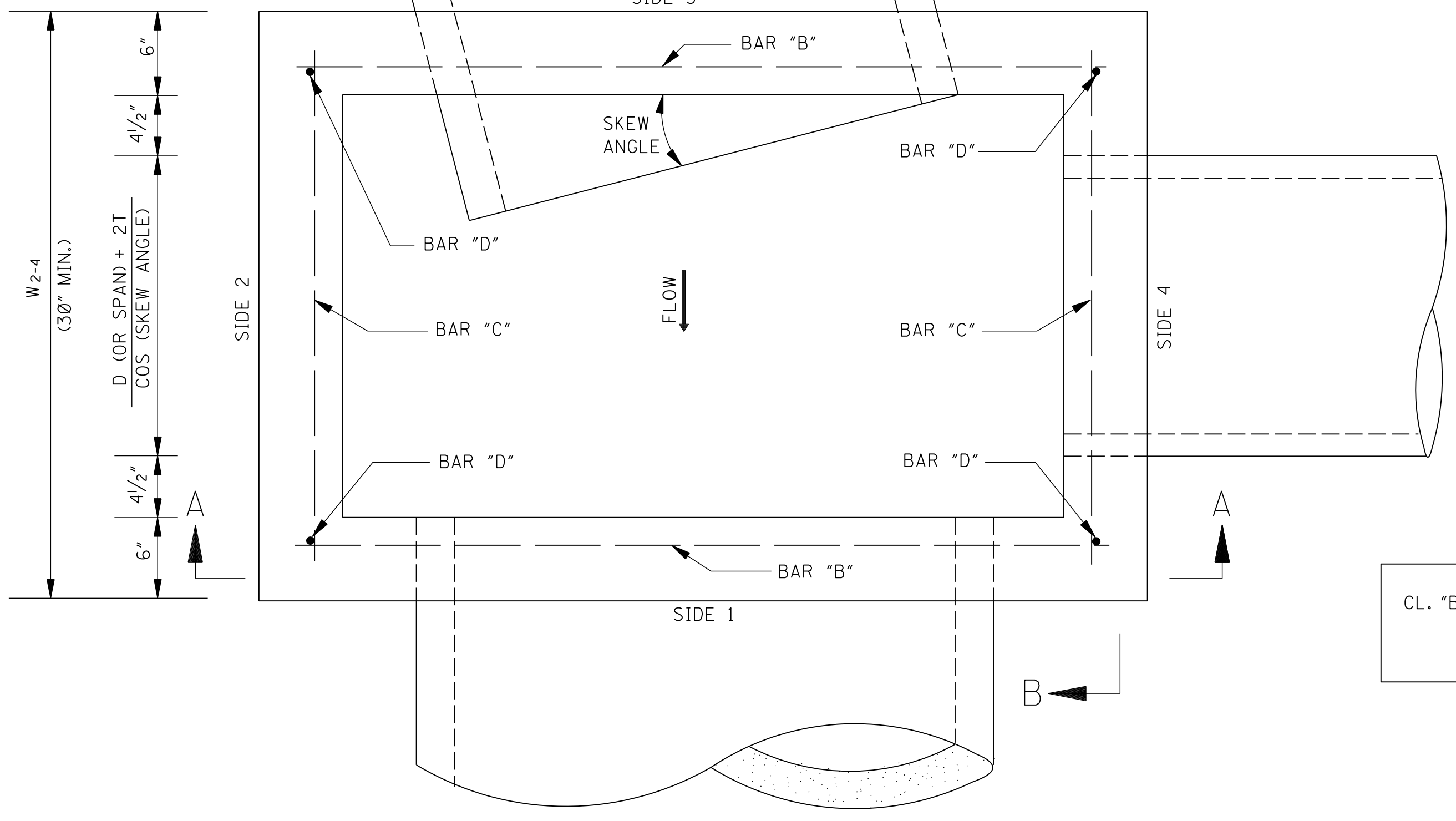

PLAN

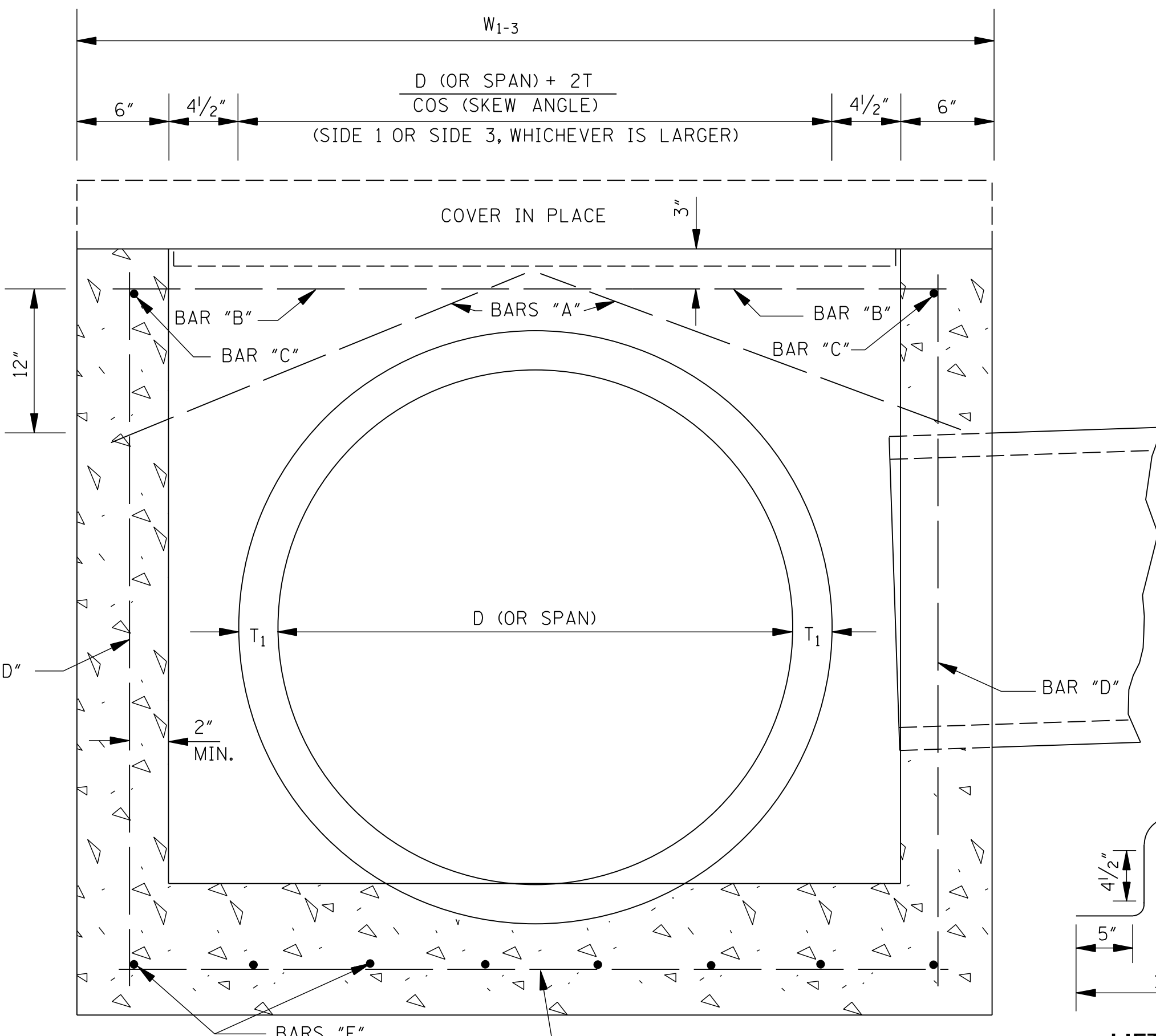

SECTION A-A

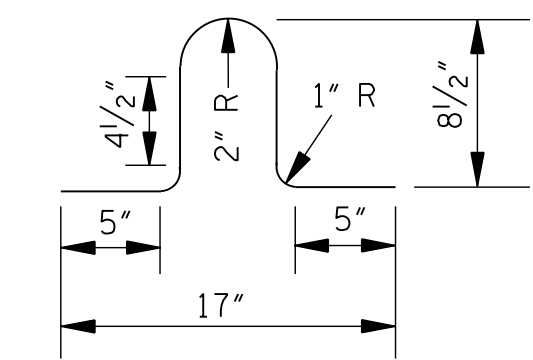

LIFT BAR

NOTE: LIFT BAR TO BE FABRICATED FROM A #4 BAR 30" LONG. TWO LIFT BARS ARE REQUIRED. REINFORCING STEEL FOR 2 LIFT BARS = 3.3 lbs.

BAR	SIZE	NUMBER REQUIRED	LENGTH
A	#4	2 PER PIPE OPENING	$\sqrt{196 + \left(\frac{W^*}{2} + 2\right)^2}$
B	#4	2	$W_{1-3} - 6"$
C	#4	2	$W_{2-4} - 6"$
D	#4	4	$H - 6"$
E	#4	$2 \left[\left(\frac{W_{1-3}}{9"} \right) ** + 1 \right]$	$W_{2-4} - 4"$
F	#4	$2 \left[\left(\frac{W_{2-4}}{9"} \right) ** + 1 \right]$	$W_{1-3} - 4"$

NOTE: VARIABLES AND DESIGNATIONS ARE AS FOLLOWS:
D (OR SPAN) = PIPE DIAMETER (OR SPAN)
W₁₋₃ = WIDTH OF SIDE 1 & SIDE 3
W₂₋₄ = WIDTH OF SIDE 2 & SIDE 4
W* = W₁₋₃ OR W₂₋₄ (SIDE OF ENTERING PIPE)
** = ROUND TO NEAREST WHOLE NUMBER

CL. "B" CONC. (yd³) = [(Q1 + Q2) / 46,656] - Σ PIPE OPENING DEDUCTIONS
WHERE: Q1 = [5"W₁₋₃W₂₋₄] + [1"(W₁₋₃ - 12.5"W₂₋₄ - 12.5") + [(T₁ + 6")W₁₋₃W₂₋₄]
Q2 = 12"[H - (T₁ + 6")][(W₁₋₃ - 12") + W₂₋₄]

CIRCULAR PIPE			ARCH PIPE		
PIPE SIZE	T	PIPE OPENING DEDUCTION (yd ³)	PIPE SIZE	T	PIPE OPENING DEDUCTION (yd ³)
18"	2 1/2"	0.053	22" x 13"	2 1/2"	0.053
24"	3"	0.091	29" x 18"	3"	0.087
30"	3 1/2"	0.138	36" x 23"	3 1/2"	0.129
36"	4"	0.196	44" x 27"	4"	0.185
42"	4 1/2"	0.263	51" x 31"	4 1/2"	0.245
48"	5"	0.340	58" x 36"	5"	0.318
54"	5 1/2"	0.427	65" x 40"	5 1/2"	0.394
60"	6"	0.524	73" x 45"	6"	0.489
66"	6 1/2"	0.630			
72"	7"	0.747			

GENERAL NOTES:

1. REINFORCING STEEL QUANTITIES TO BE COMPUTED FROM BAR LIST AND SHOWN ELSEWHERE ON THE PLANS.
2. QUANTITIES FOR JUNCTION BOXES SHOWN ON THE PLANS WILL BE THE BASIS FOR PAYMENT UNLESS AUTHORIZED MODIFICATIONS ARE MADE.
3. CONCRETE SHALL BE CLASS "B" AND REINFORCING STEEL SHALL BE DEFORMED BARS.
4. SIDE 1 OF THE JUNCTION BOX WILL ALWAYS BE THE OUTFLOW SIDE.
5. IF PIPES ARE SKEWED MORE THAN 15° OR IF SKEWED PIPES PRODUCE CONFLICTS WITH ANOTHER OPENING, THE PIPE SHALL BE BROKEN BACK TO THE WALL OF THE JUNCTION BOX.

BY		MISSISSIPPI DEPARTMENT OF TRANSPORTATION ROADWAY DESIGN DIVISION STANDARD PLAN	
REVISION		<p align="center">JUNCTION BOX FOR PIPE CULVERTS</p> 	
DATE			
ISSUE DATE: AUGUST 01, 2017		WORKING NUMBER JB-1	SHEET NUMBER 6504

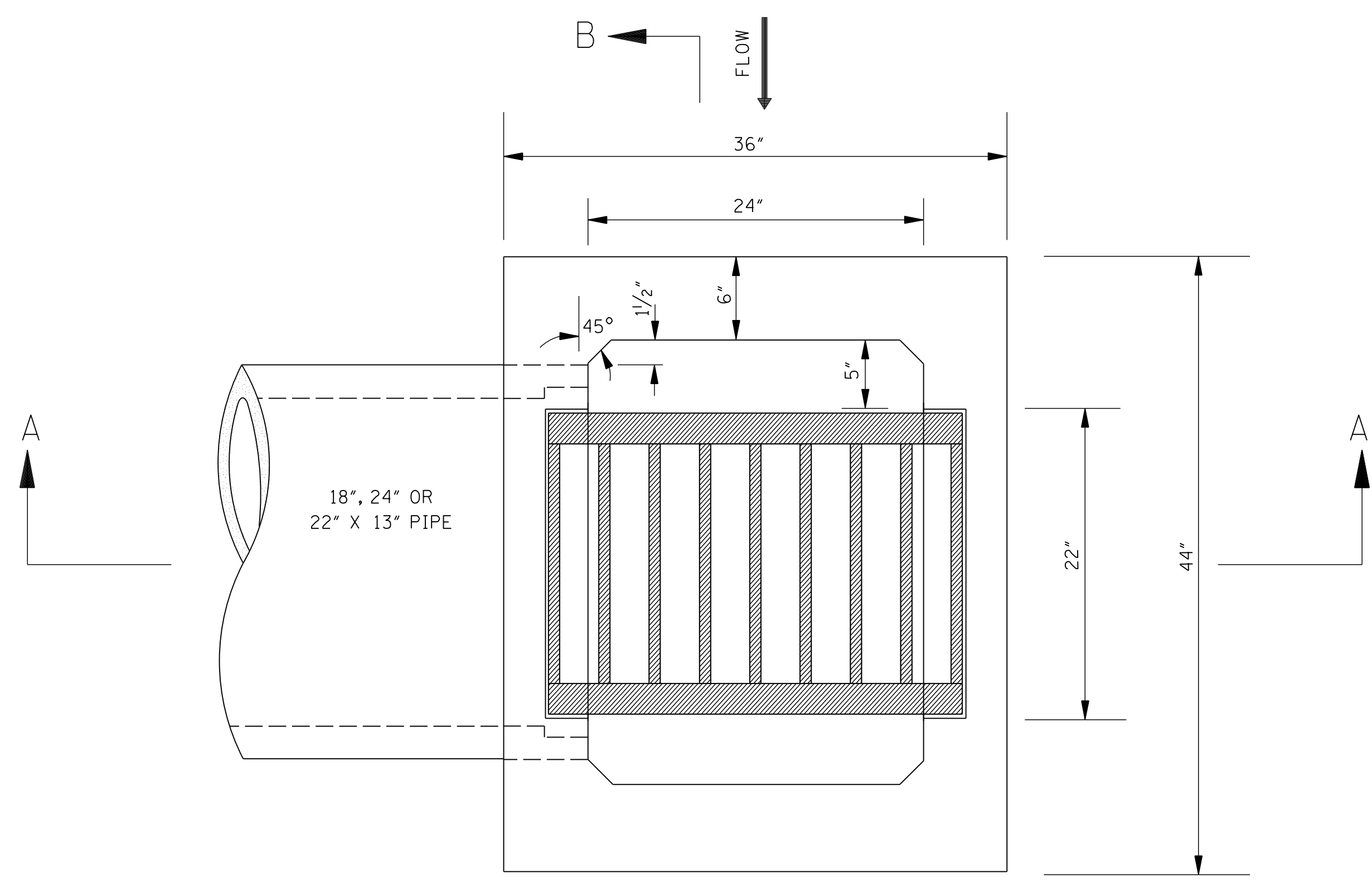

PLAN OF CONCRETE DIMENSIONS

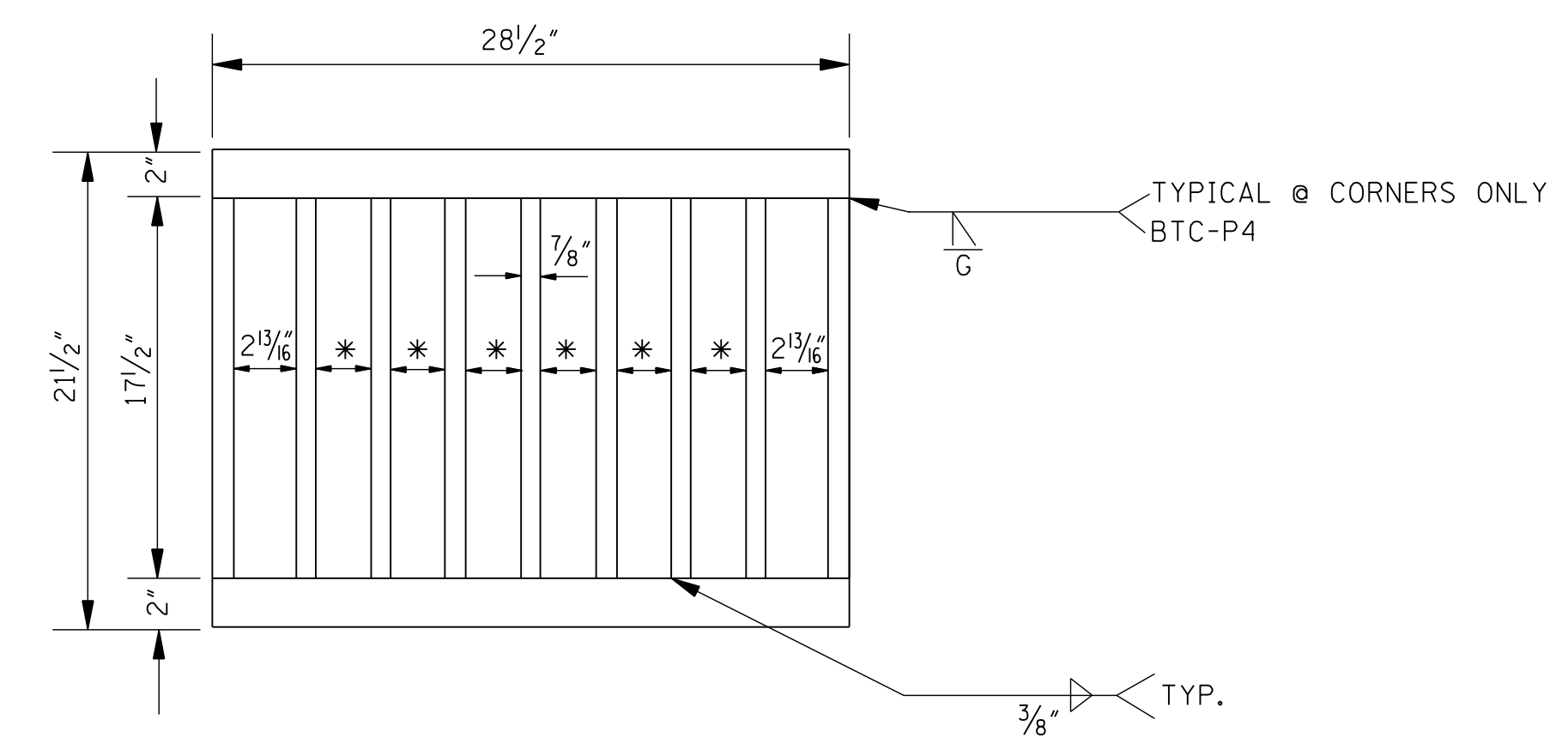

PLAN OF GRATE NO.1

* NOTE: TYPICAL SPACING 2 1/8"

PIPE SIZE	MIN. DEPTH TO F.L.	QUANTITIES				T	PIPE OPENING DEDUCTION (yd ³)
		MIN. DEPTH INLET		EACH ADDED FOOT			
		CONC. (yd ³)	STEEL (lbs)	CONC. (yd ³)	STEEL (lbs)		
18"	2.500'	0.670	48	0.211	10	2 1/2"	0.053
24"	3.042'	0.747	54	0.211	10	3"	0.091
22" X 13"	2.125'	0.591	46	0.211	10	2 1/2"	0.053

NOTE: ONE (1) PIPE OPENING DEDUCTED FROM INLET.

PIPE SIZE	BARS/SIZES			
	"A" #4	"B" #4	"C" #4	"D" #4
	NO. @ LGTH.	NO. @ LGTH.	NO. @ LGTH.	NO. @ LGTH.
18"	2 @ 1'-6"	6 @ 3'-2"	10 @ 2'-5"	10 @ 2'-6"
24"	2 @ 1'-6"	7 @ 3'-2"	10 @ 2'-5"	10 @ 3'-1"
22" X 13"	2 @ 1'-6"	6 @ 3'-2"	10 @ 2'-5"	10 @ 2'-4"

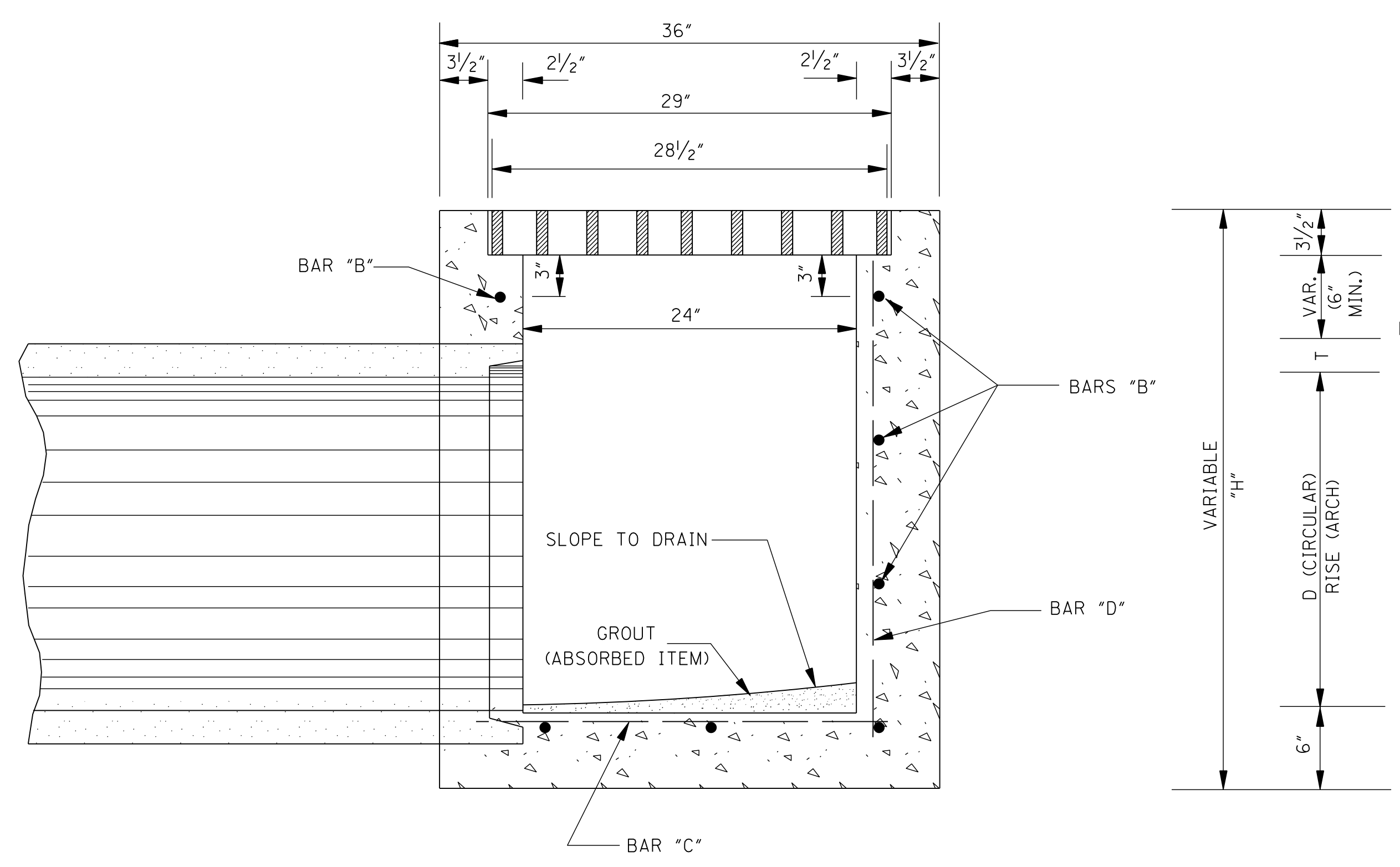

SECTION A-A

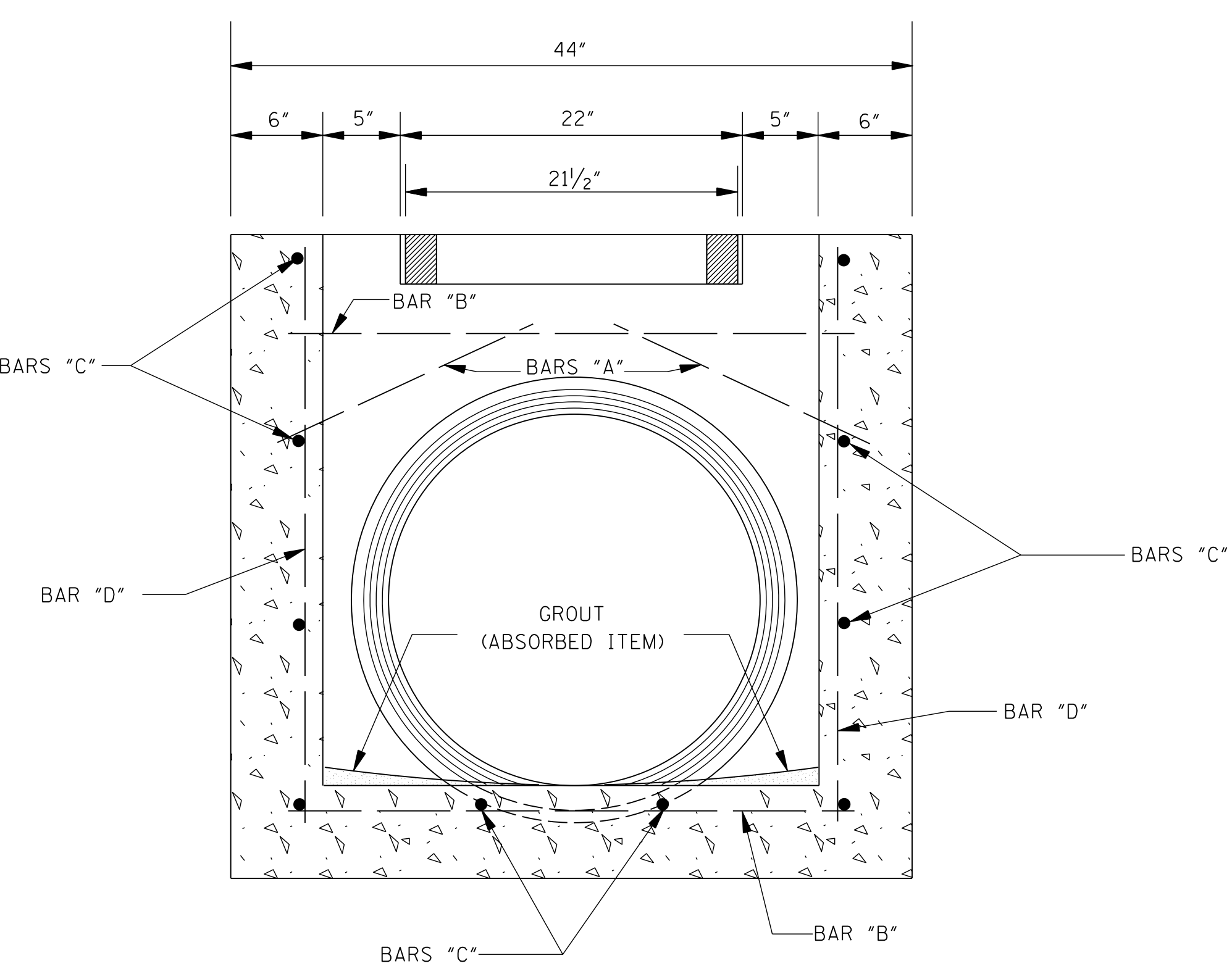

SECTION B-B

GENERAL NOTES:

- QUANTITIES SHOWN WILL BE THE BASIS OF PAYMENT UNLESS AUTHORIZED MODIFICATIONS ARE MADE.
- INLET:
 - THE INLET ON THIS DRAWING IS SHOWN AS THE ENTRANCE TO A PIPE CULVERT BUT MAY ALSO BE USED ON A CROSSDRAIN.
 - THE CONCRETE SHALL BE CLASS "B".
 - THE REINFORCEMENT SHALL BE SPACED A MAXIMUM OF 12" ON CENTER BOTH WAYS WITH A MINIMUM CLEARANCE OF 1" TO THE INSIDE OF THE INLET WALLS.
- GRATE: THE CONTRACTOR HAS THE OPTION TO PROVIDE GRATE NO. 1 OR GRATE NO. 2 AS SHOWN ON SHEET IG-1.

BY	MISSISSIPPI DEPARTMENT OF TRANSPORTATION ROADWAY DESIGN DIVISION STANDARD PLAN
REVISION	
DATE	ISSUE DATE: AUGUST 01, 2017

**TYPE I MEDIAN INLET
(24" PIPE AND UNDER)**

WORKING NUMBER	MI-1
SHEET NUMBER	6508

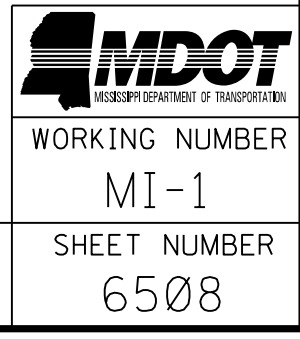

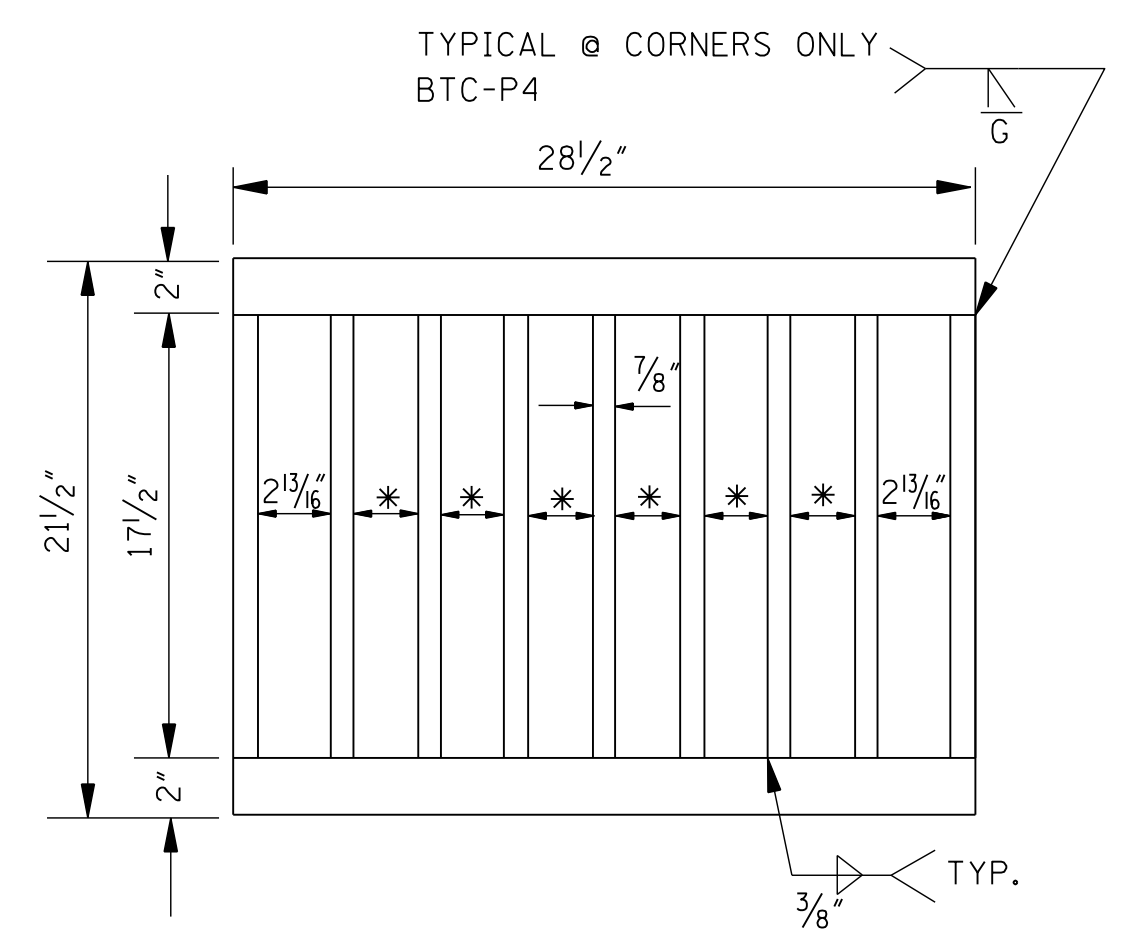

PLAN OF GRATE NO. 1

*NOTE: TYPICAL SPACING 2 1/2"

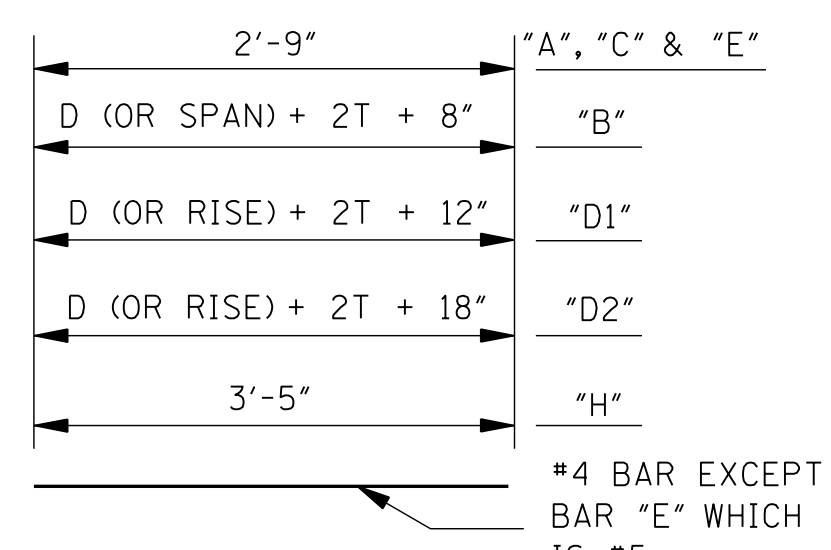

BARS "A", "C", "E", "B", "D1", "D2" & "H"

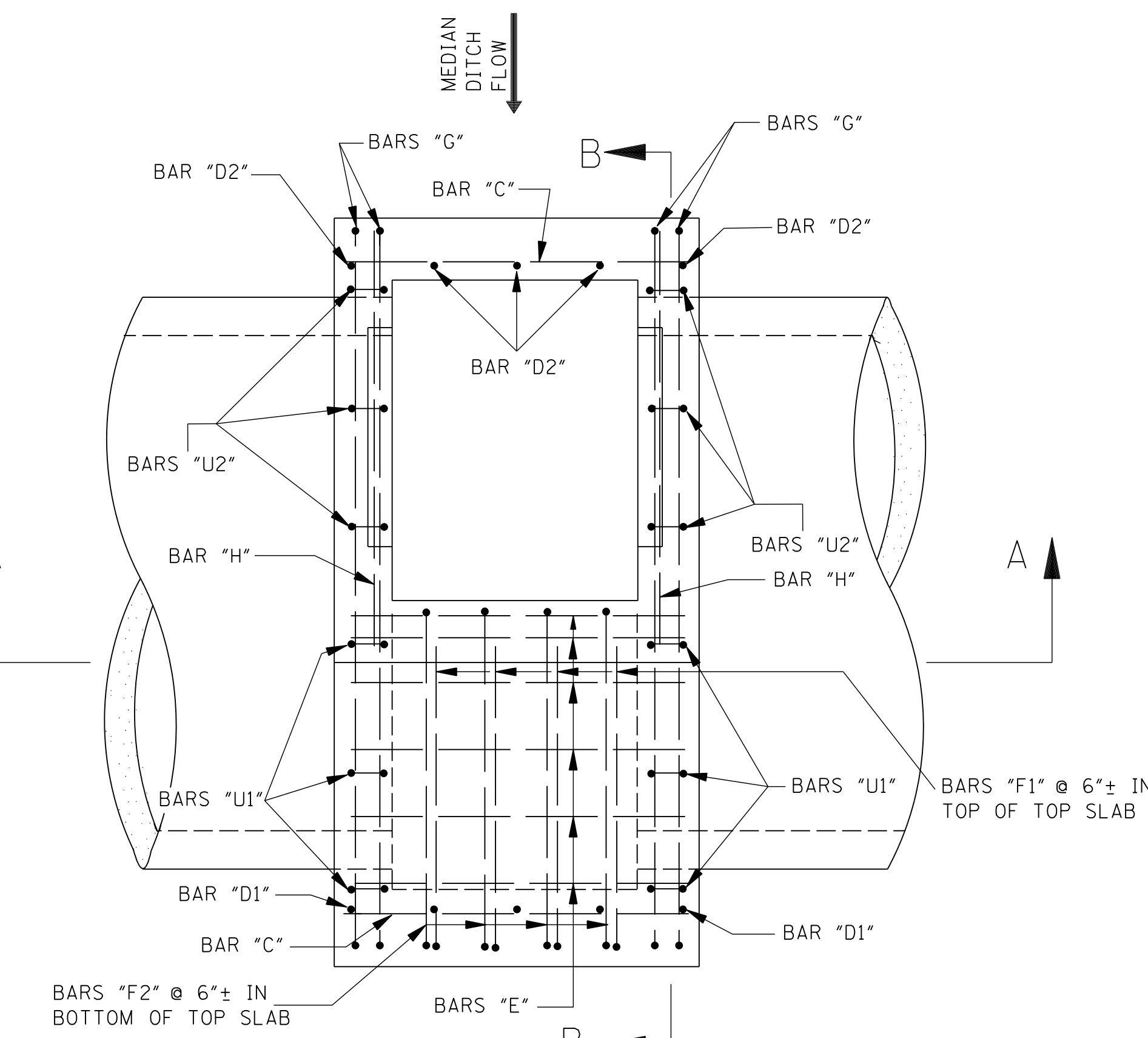

PLAN OF REBAR LAYOUT

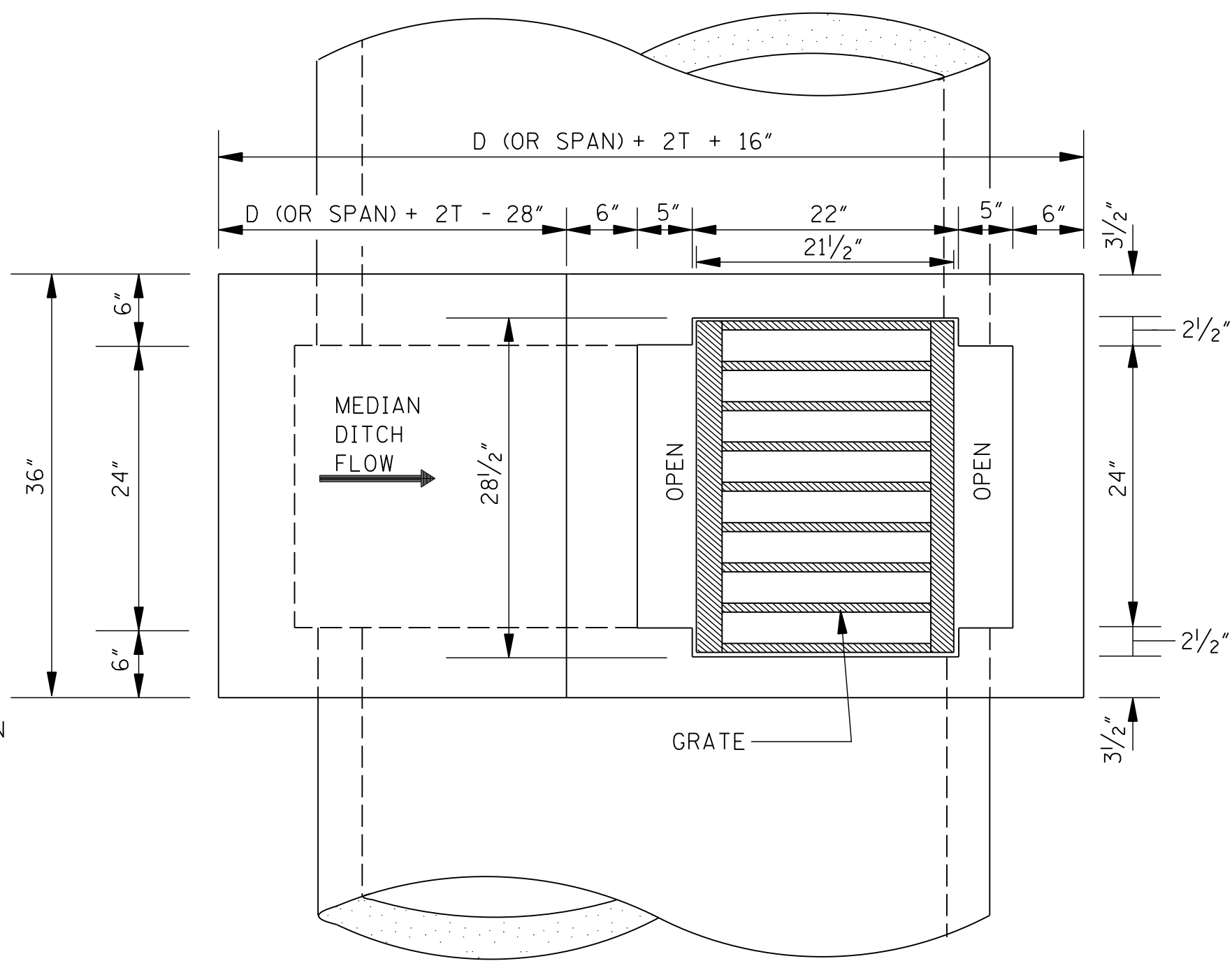

PLAN OF CONCRETE DIMENSIONS

PIPE SIZES	BAR LIST											
	BARS/SIZES											
	"A"	"B"	"C"	"D1"	"D2"	"E"	"F1"	"F2"	"G"	"H"	"U1"	"U2"
	#4	#4	#4	#4	#4	#5	#5	#5	#5	#4	#4	#4
LENGTHS												
	2'-9"	L _B	2'-9"	L _{D1}	L _{D2}	2'-9"	L _{F1}	L _{F2}	L _G	3'-5"	1'-10"	L _{U2}
NUMBER OF BARS												
30"	4	4	15	4	4	4	4	4	8	2	2	6
36"	4	4	17	4	4	6	4	4	8	2	2	6
42"	4	4	18	4	4	7	4	4	8	2	4	6
48"	4	4	20	4	4	8	4	4	8	2	4	6
29" X 18"	4	4	12	4	4	4	4	4	8	2	2	6
36" X 23"	4	4	13	4	4	6	4	4	8	2	2	6
44" X 27"	4	4	16	4	4	7	4	4	8	2	4	6
51" X 31"	4	4	17	4	4	8	4	4	8	2	6	6

NOTES:
 *1. USE #6 BARS FOR A 51" X 31" ARCH PIPE.
 2. BAR SPACINGS FOR ADDITIONAL INLET HEIGHTS:
 BARS "E" @ 6"±
 BARS "H" @ 11"±
 BARS "C" @ 11"±

PIPE SIZE	MIN. DEPTH TO F.L.	MIN. DEPTH INLET		EACH ADDED FOOT		T	PIPE OPENING DEDUCTION (yd ³)
		CONC. (yd ³)	STEEL (lbs)	CONC. (yd ³)	STEEL (lbs)		
30"	4.29'	1.138	161	0.210	25	3 1/2"	0.138
36"	4.85'	1.341	185	0.210	25	4"	0.196
42"	5.38'	1.554	206	0.210	25	4 1/2"	0.263
48"	5.92'	1.776	227	0.210	25	5"	0.340
29" X 18"	3.25'	0.935	146	0.210	25	3"	0.087
36" X 23"	3.71'	1.139	170	0.210	25	3 1/2"	0.129
44" X 27"	4.08'	1.343	197	0.210	25	4"	0.185
51" X 31"	4.46'	1.543	259	0.210	25	4 1/2"	0.245

NOTE: TWO PIPE OPENINGS HAVE BEEN DEDUCTED.

- GENERAL NOTES:
- QUANTITIES SHOWN WILL BE THE BASIS OF PAYMENT UNLESS AUTHORIZED MODIFICATIONS ARE MADE.
 - INLET:
 - THE CONCRETE SHALL BE CLASS "B".
 - THE REINFORCEMENT SHALL BE SPACED A MAXIMUM OF 12" ON CENTER BOTH WAYS WITH A MINIMUM CLEARANCE OF 1" TO THE INSIDE OF THE INLET WALLS. SEE CHART FOR BAR SIZES.
 - GRATE: THE CONTRACTOR HAS THE OPTION TO PROVIDE GRATE NO. 1 OR GRATE NO. 2 AS SHOWN ON SHEET IG-1.

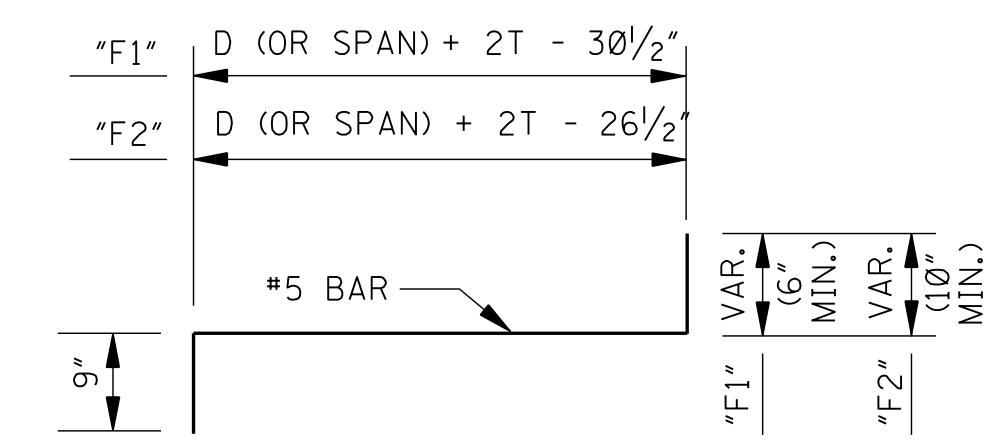

BARS "F1" & "F2"

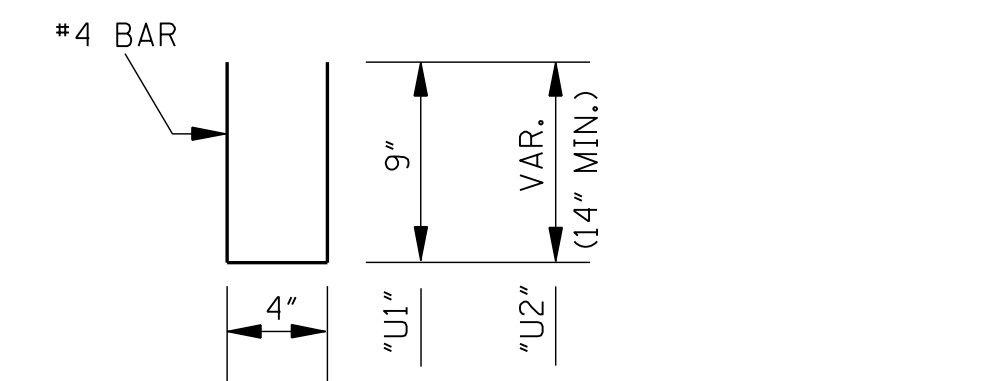

BARS "U1" & "U2"

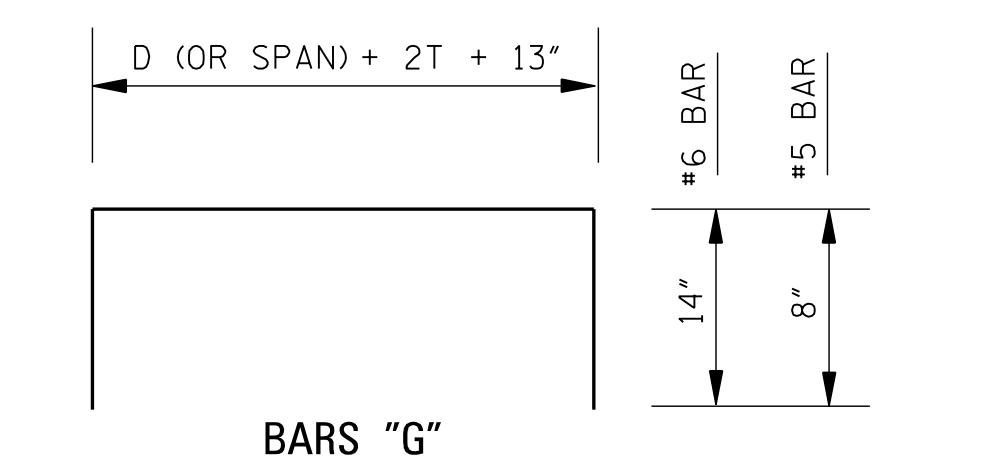

BARS "G"

NOTE: BARS "G" ARE #5 BARS FOR ALL CIRCULAR PIPES AND FOR PIPE ARCHES UP TO AND INCLUDING A 44" SPAN. FOR PIPE ARCHES WITH A SPAN LARGER THAN 44", USE #6 BARS FOR BARS "G".

BAR DETAILS

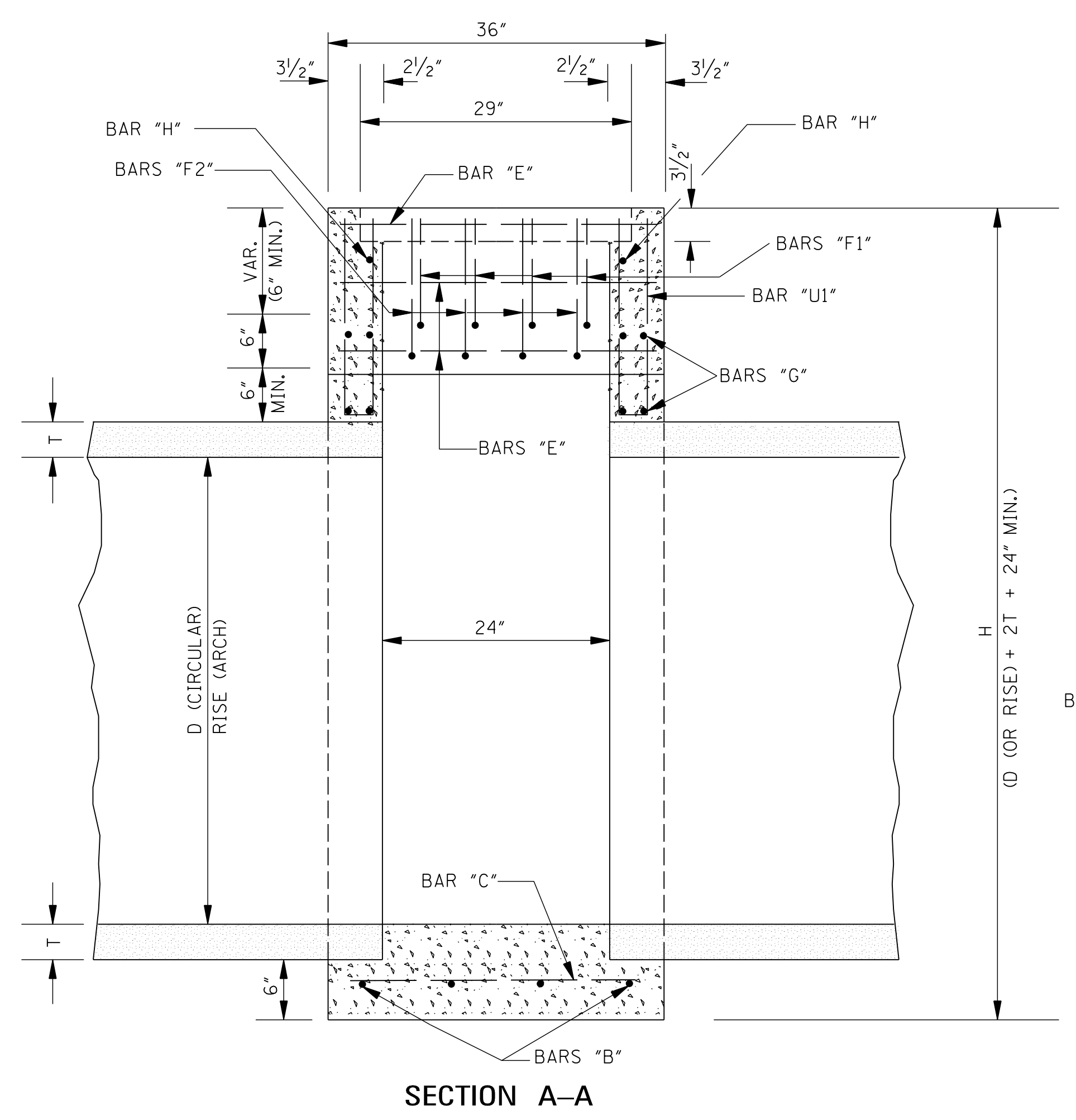

SECTION A-A

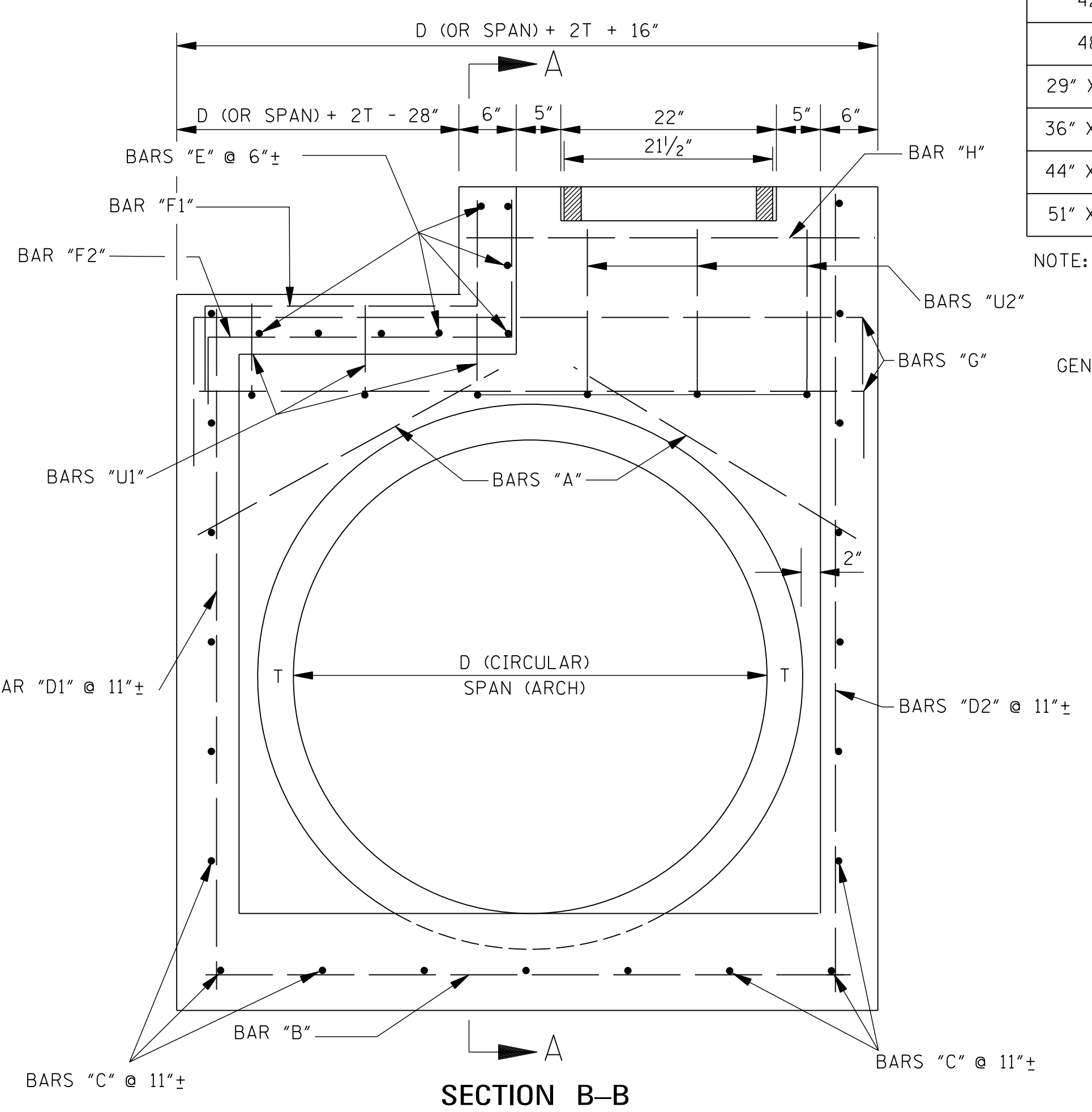

SECTION B-B

BY	MISSISSIPPI DEPARTMENT OF TRANSPORTATION ROADWAY DESIGN DIVISION STANDARD PLAN
REVISION	
DATE	ISSUE DATE: AUGUST 01, 2017

TYPE I MEDIAN INLET
(29" TO 51" PIPE)

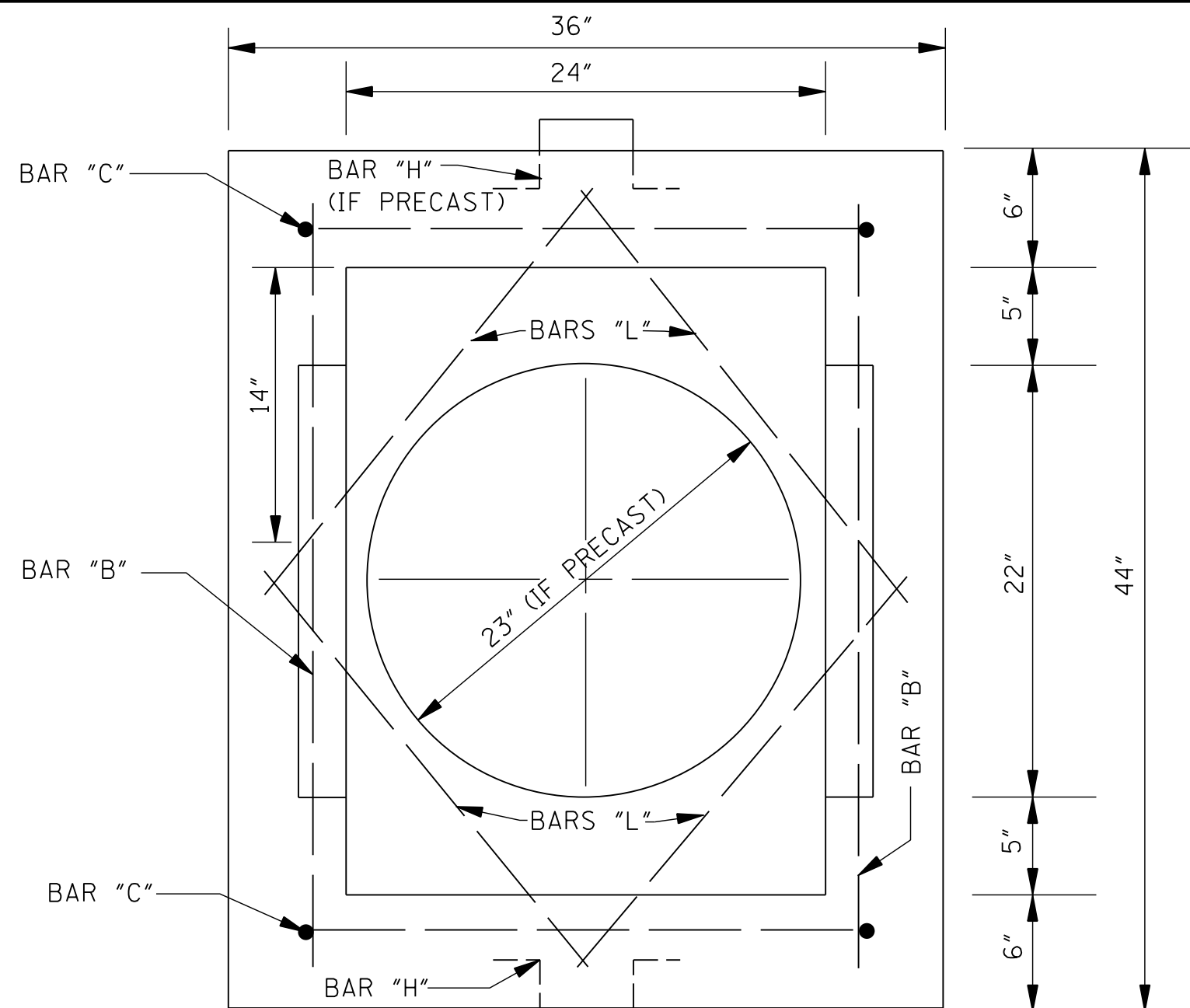

 WORKING NUMBER MI-1A
 SHEET NUMBER 6509

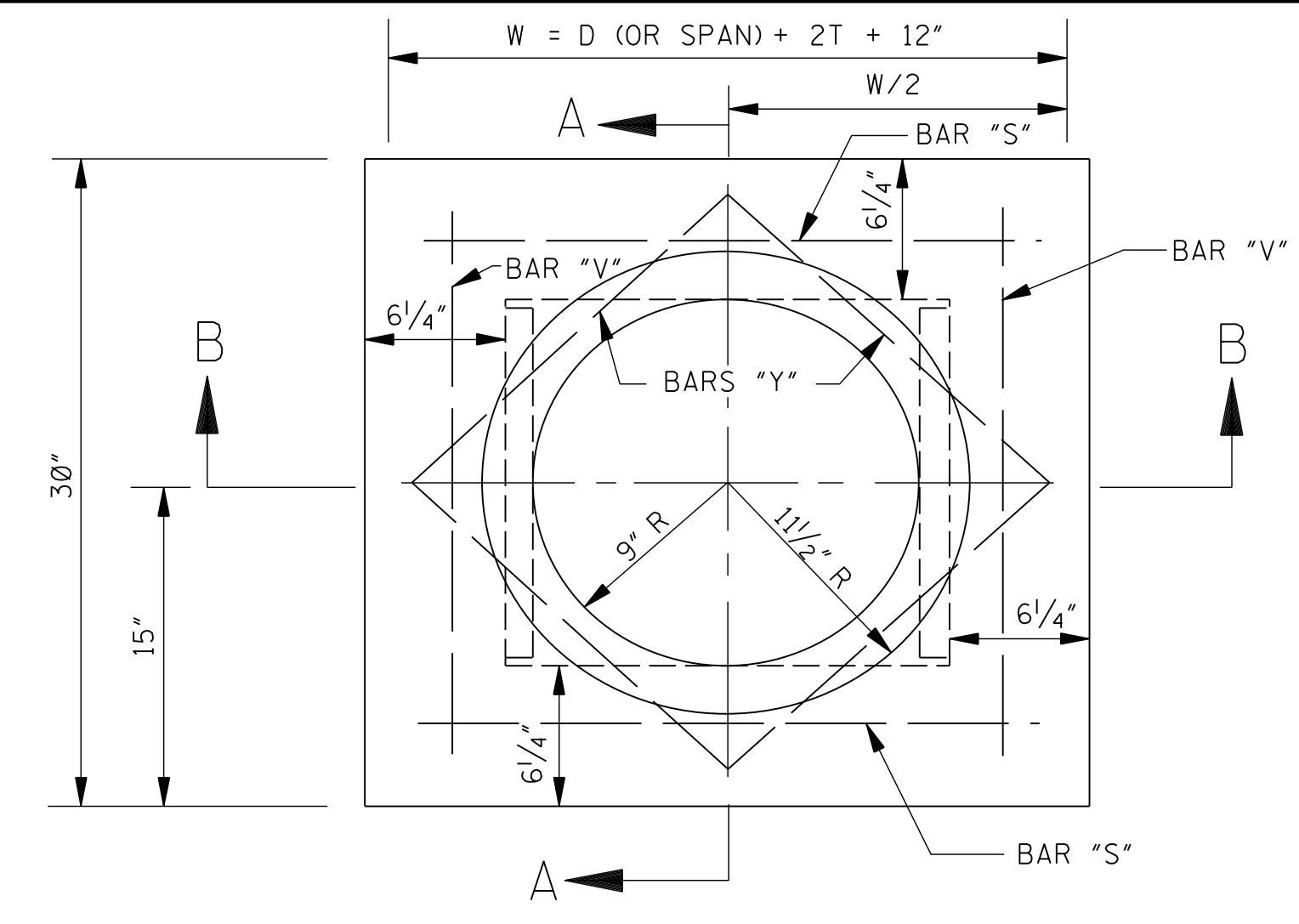

PLAN OF INLET

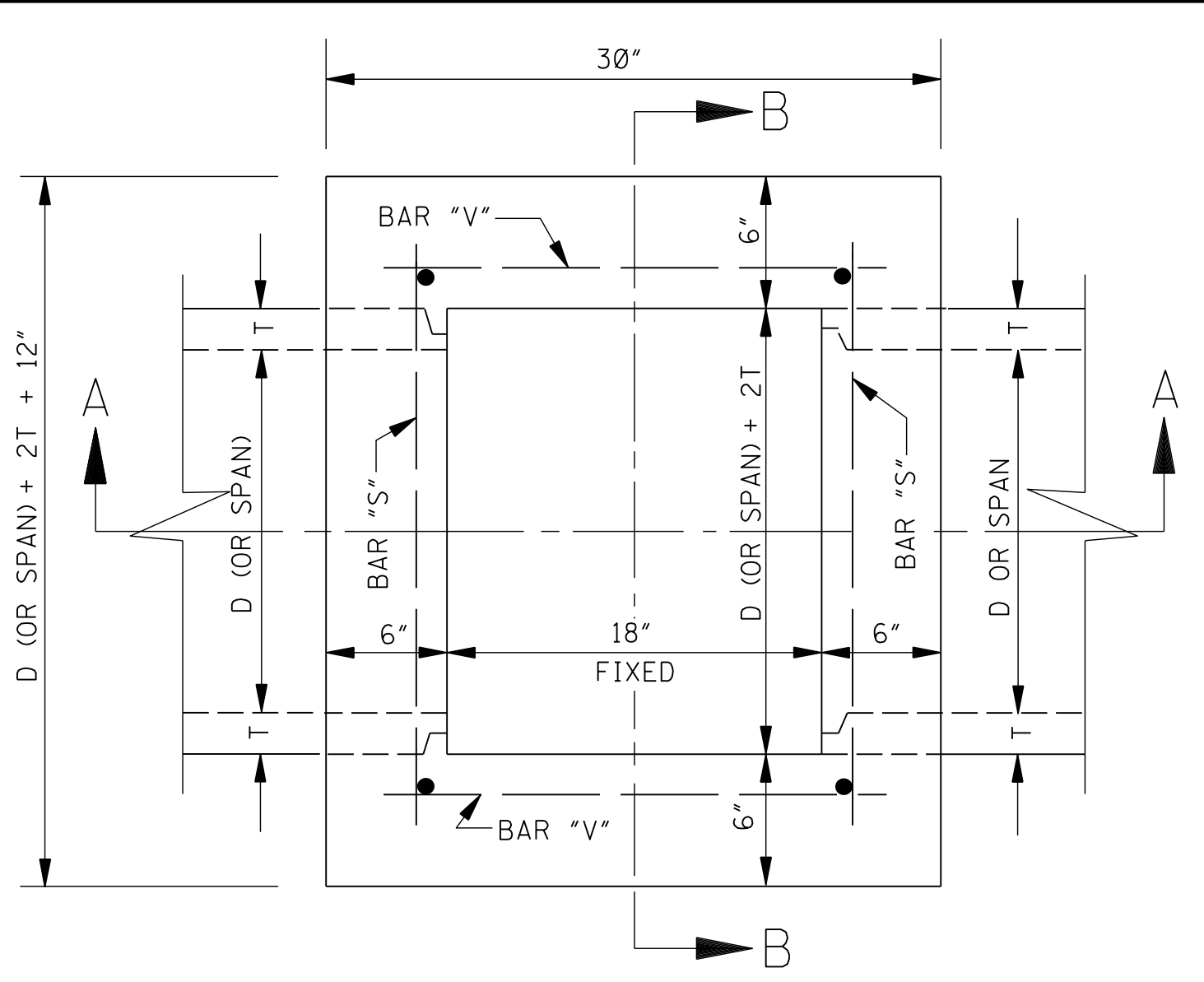

PLAN OF PRECAST COVER



PLAN OF JUNCTION BOX

QUANTITIES FOR JUNCTION BOX & INLET				
PIPE SIZE	T	CONC. (yd ³)	STEEL (lbs)	PIPE OPENING DEDUCTION (yd ³)
18"	2 1/2"	0.914	64	0.053
24"	3"	1.065	69	0.091
30"	3 1/2"	1.225	74	0.138
36"	4"	1.393	79	0.196
42"	4 1/2"	1.570	84	0.263
48"	5"	1.754	89	0.340
22" x 13"	2 1/2"	0.923	67	0.053
29" x 18"	3"	1.068	70	0.087
36" x 23"	3 1/2"	1.244	75	0.129
44" x 27"	4"	1.408	81	0.185
51" x 31"	4 1/2"	1.600	86	0.245

- NOTES:
- 2 PIPE OPENINGS HAVE BEEN DEDUCTED FROM JUNCTION BOX.
 - 0.378 yd³ CLASS "B" CONCRETE AND 24 lbs REINFORCING STEEL INCLUDED FOR INLET.

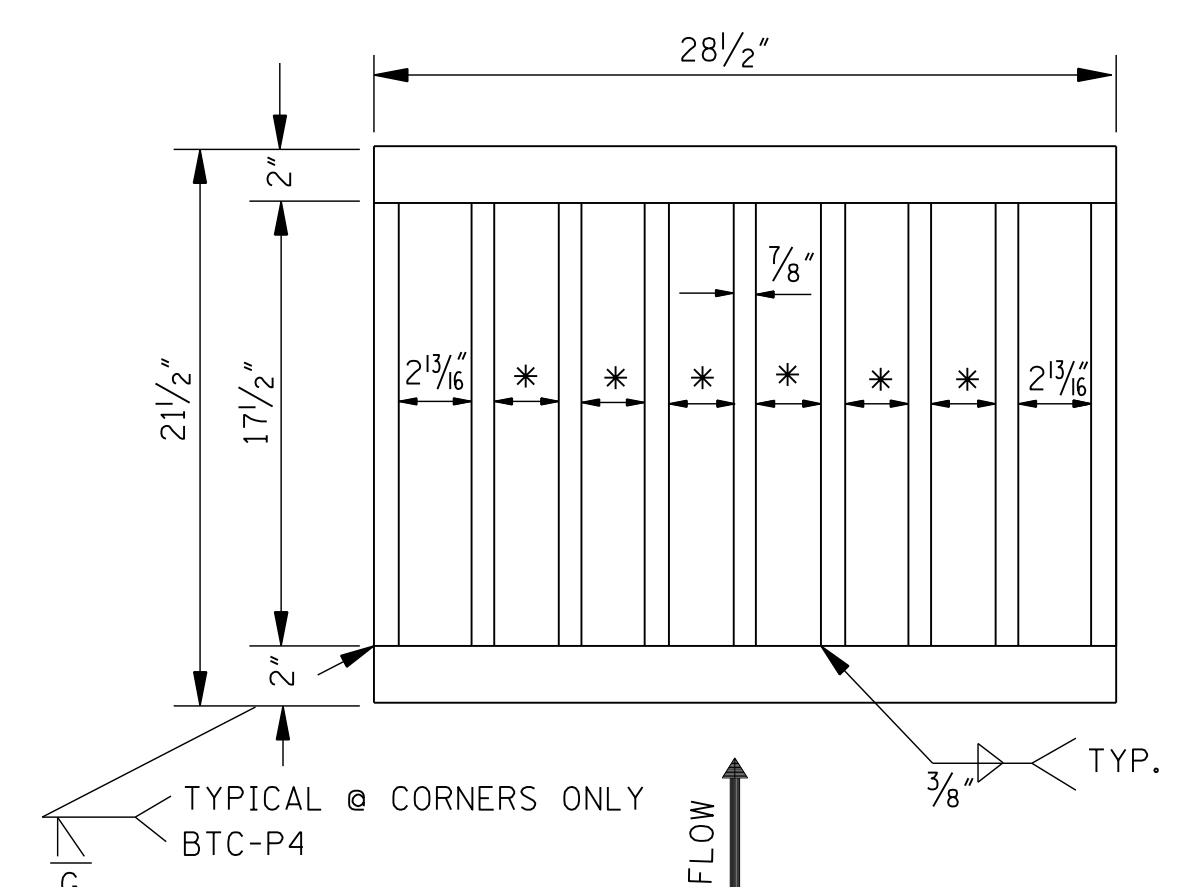

PLAN OF GRATE NO. 1
* NOTE: TYPICAL SPACING 2 1/2".

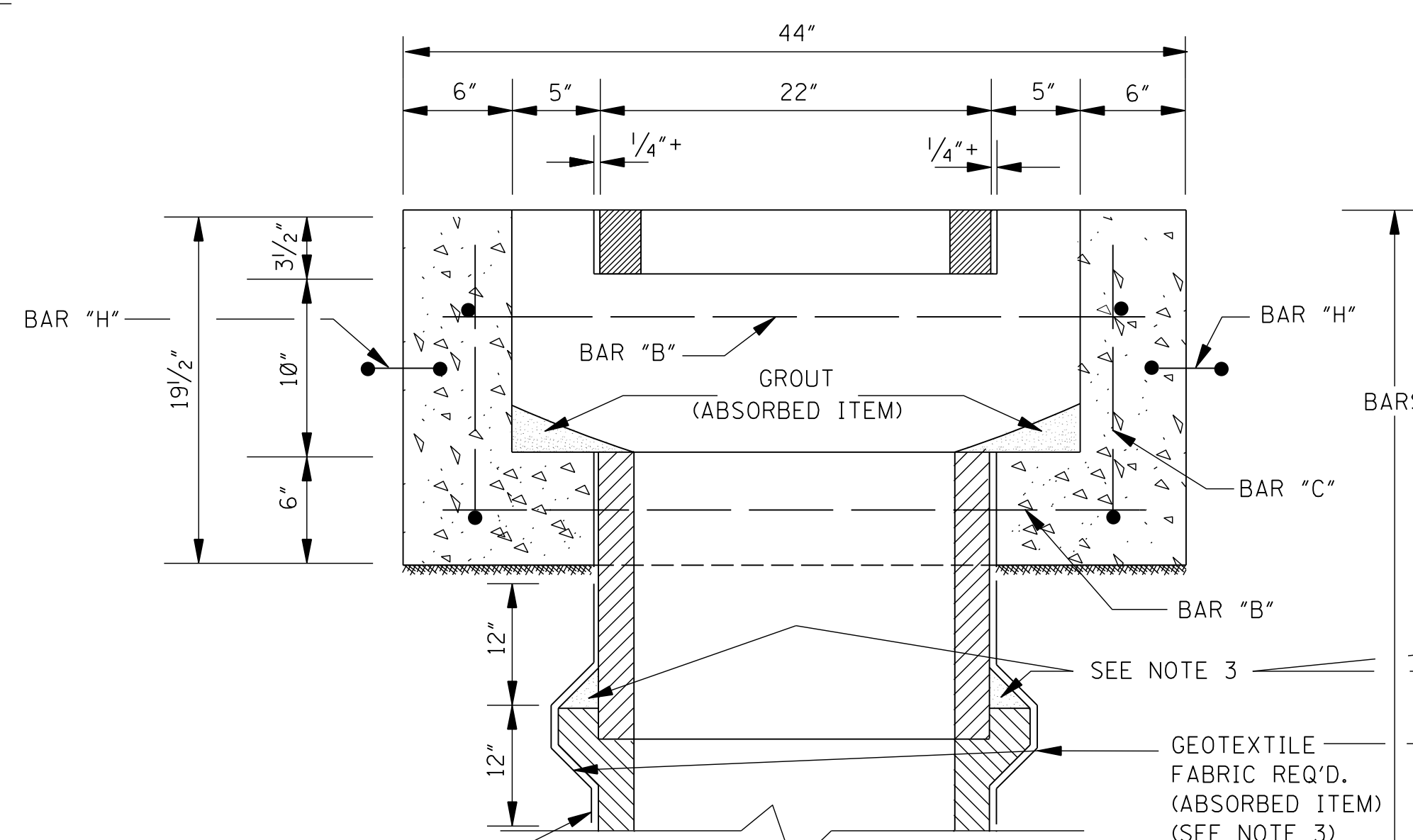

SECTION B-B

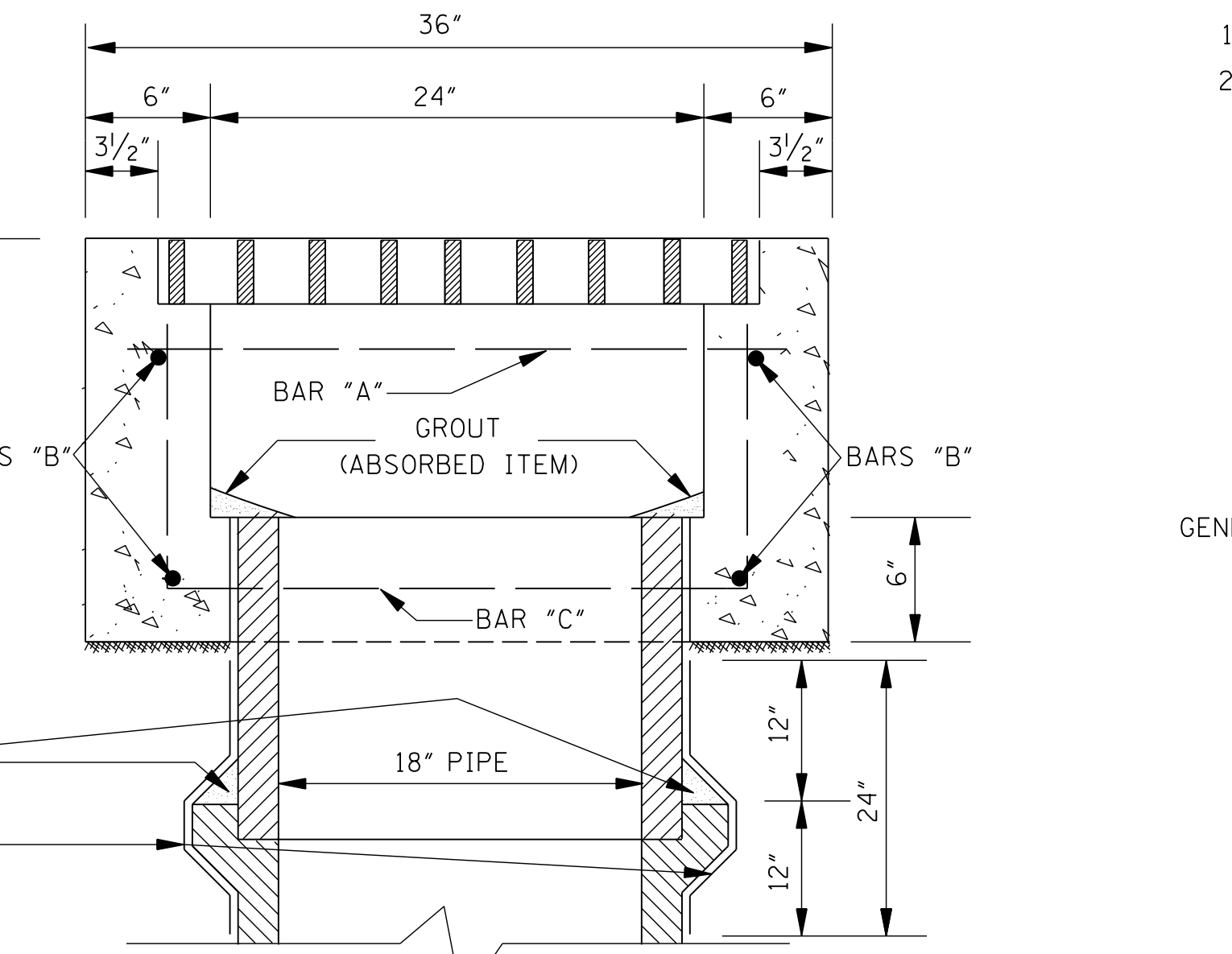

SECTION A-A

- GENERAL NOTES:
- QUANTITIES SHOWN WILL BE THE BASIS OF PAYMENT UNLESS AUTHORIZED MODIFICATIONS ARE MADE.
 - ANY STACK PIPE THAT MUST BE CUT OFF WILL BE PAID FOR AT FULL PIPE LENGTH AS THOUGH INSTALLED.
 - EACH STACKED PIPE JOINT SHALL BE SEALED WITH BUTYL PER C990 OR RUBBER GASKET PER C443 AND C1619, THEN WRAPPED WITH GEOTEXTILE FABRIC, 24" WIDE, AASHTO M 288 EOS= 100+. THE FABRIC SHALL OVERLAP A MINIMUM OF 12" AT THE WRAP AND SHALL BE SECURED WITH STRING OR WIRE FOR BACKFILLING. THE COST SHALL BE ABSORBED IN OTHERS ITEMS BID.
 - THE CONTRACTOR HAS THE OPTION TO PROVIDE GRATE NO. 1 OR GRATE NO. 2 AS SHOWN ON SHEET IG-1.
 - CONCRETE SHALL BE CLASS "B" CONCRETE AND REINFORCING STEEL SHALL BE DEFORMED BARS.

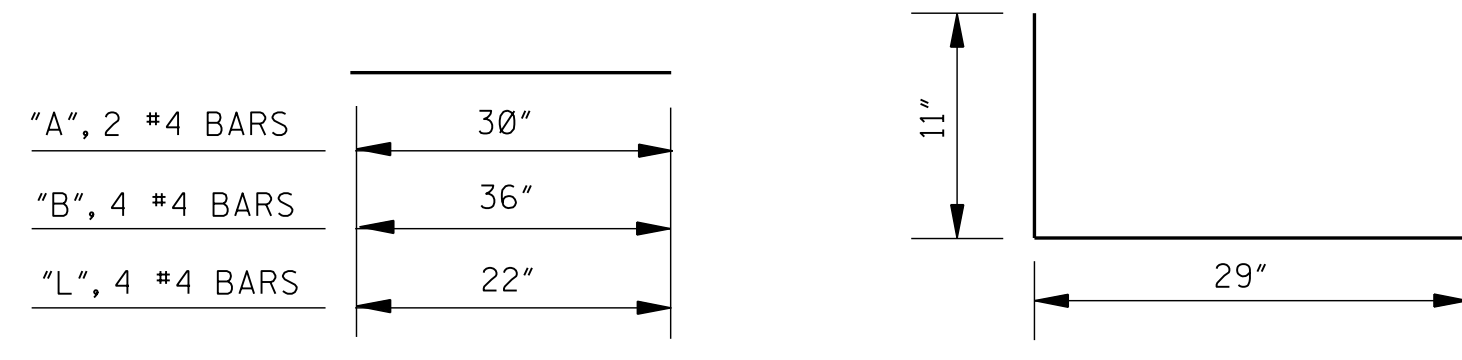

BARS "A", "B" & "L"

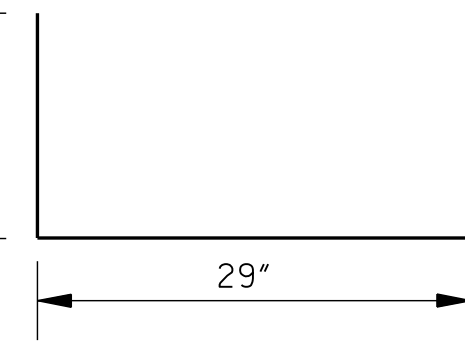

BARS "C"

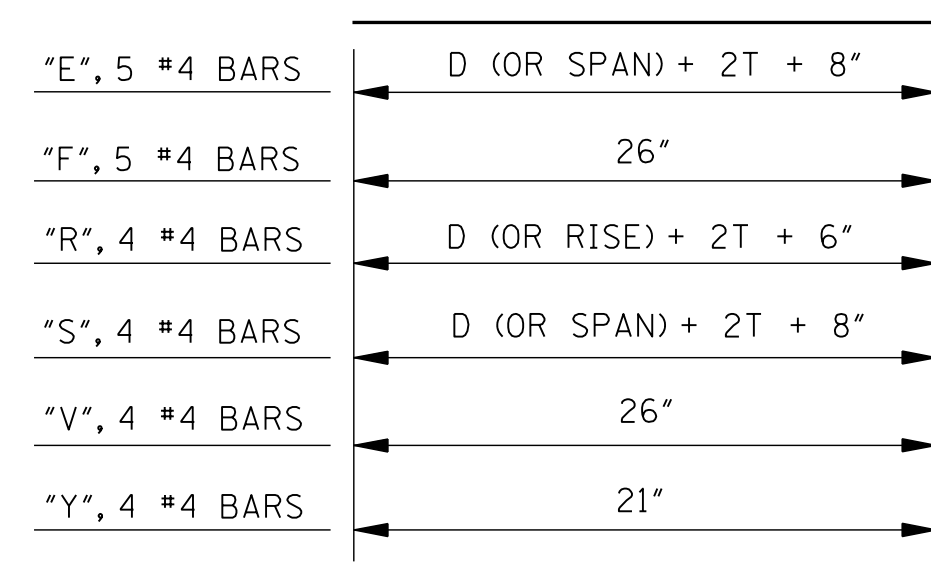

BARS "E", "F", "R", "S", "V" & "Y"

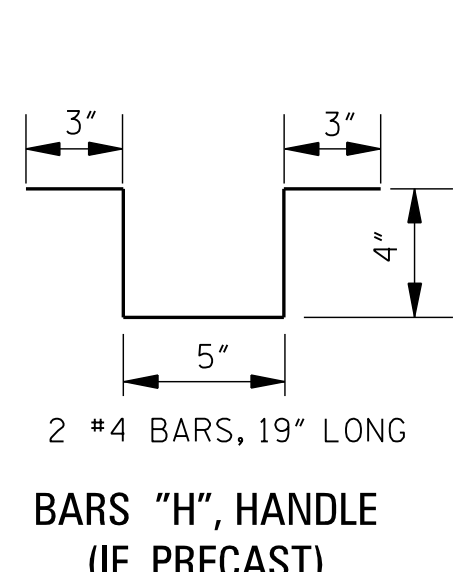

BARS "H", HANDLE (IF PRECAST)

BAR DETAILS

MISSISSIPPI DEPARTMENT OF TRANSPORTATION
ROADWAY DESIGN DIVISION
STANDARD PLAN

TYPE II MEDIAN INLET
(51" PIPE AND UNDER)

ISSUE DATE: AUGUST 01, 2017

WORKING NUMBER MI-2
SHEET NUMBER 6511

TYPE I INLET

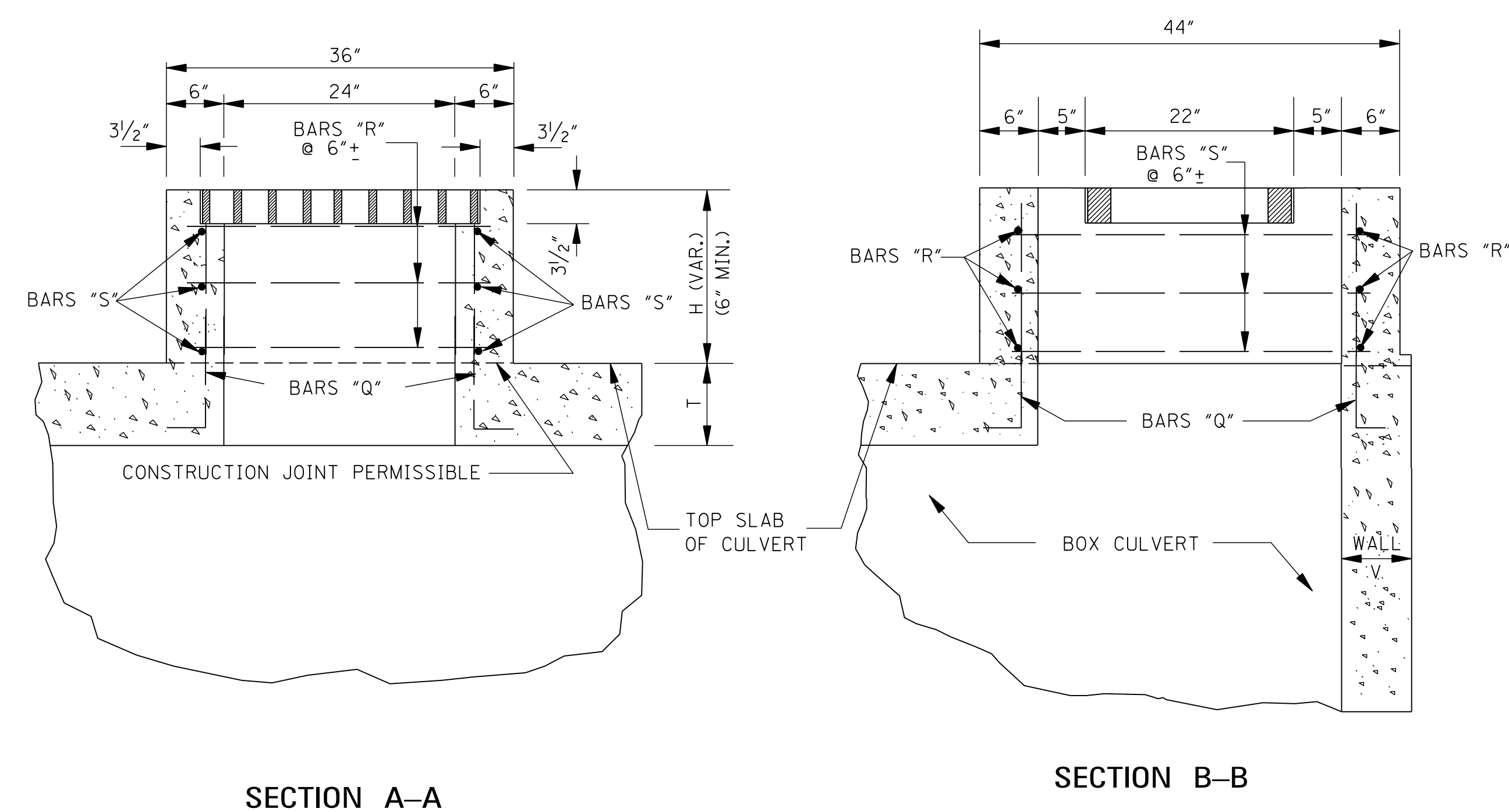
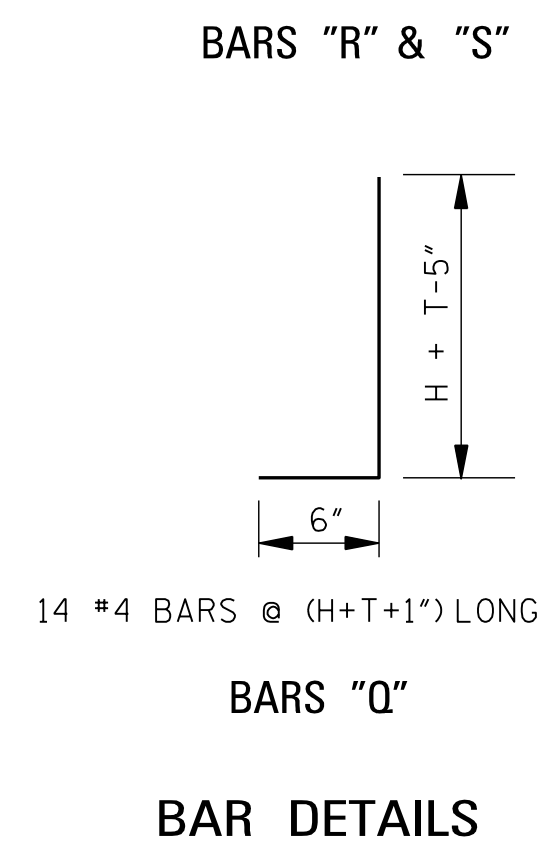
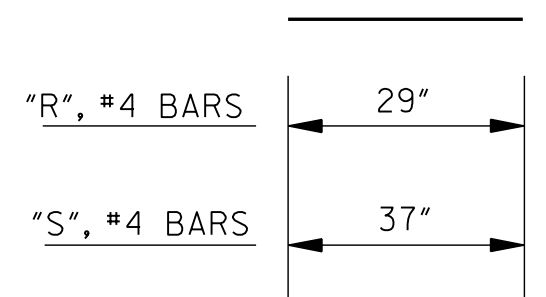
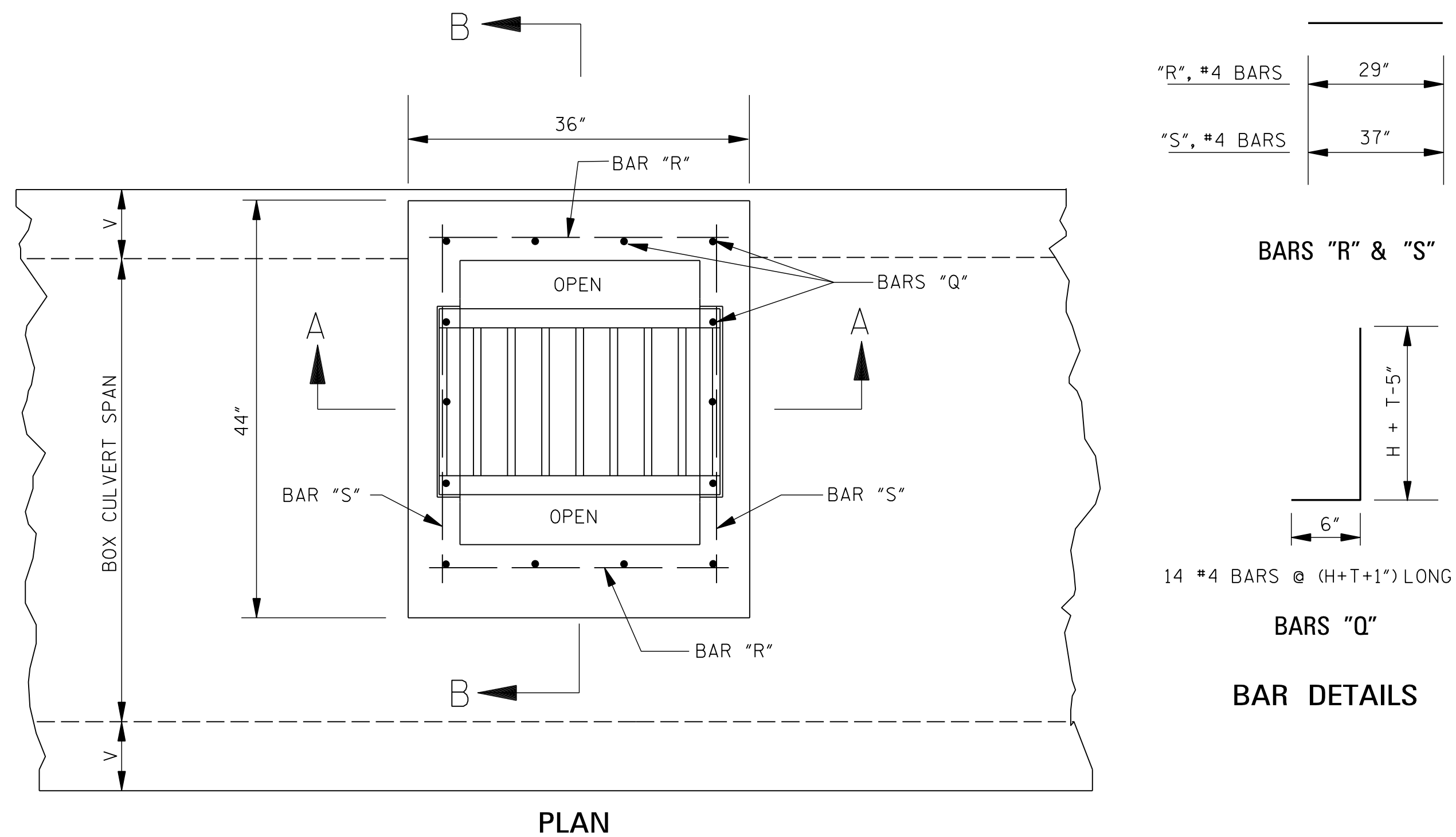

TYPE II INLET

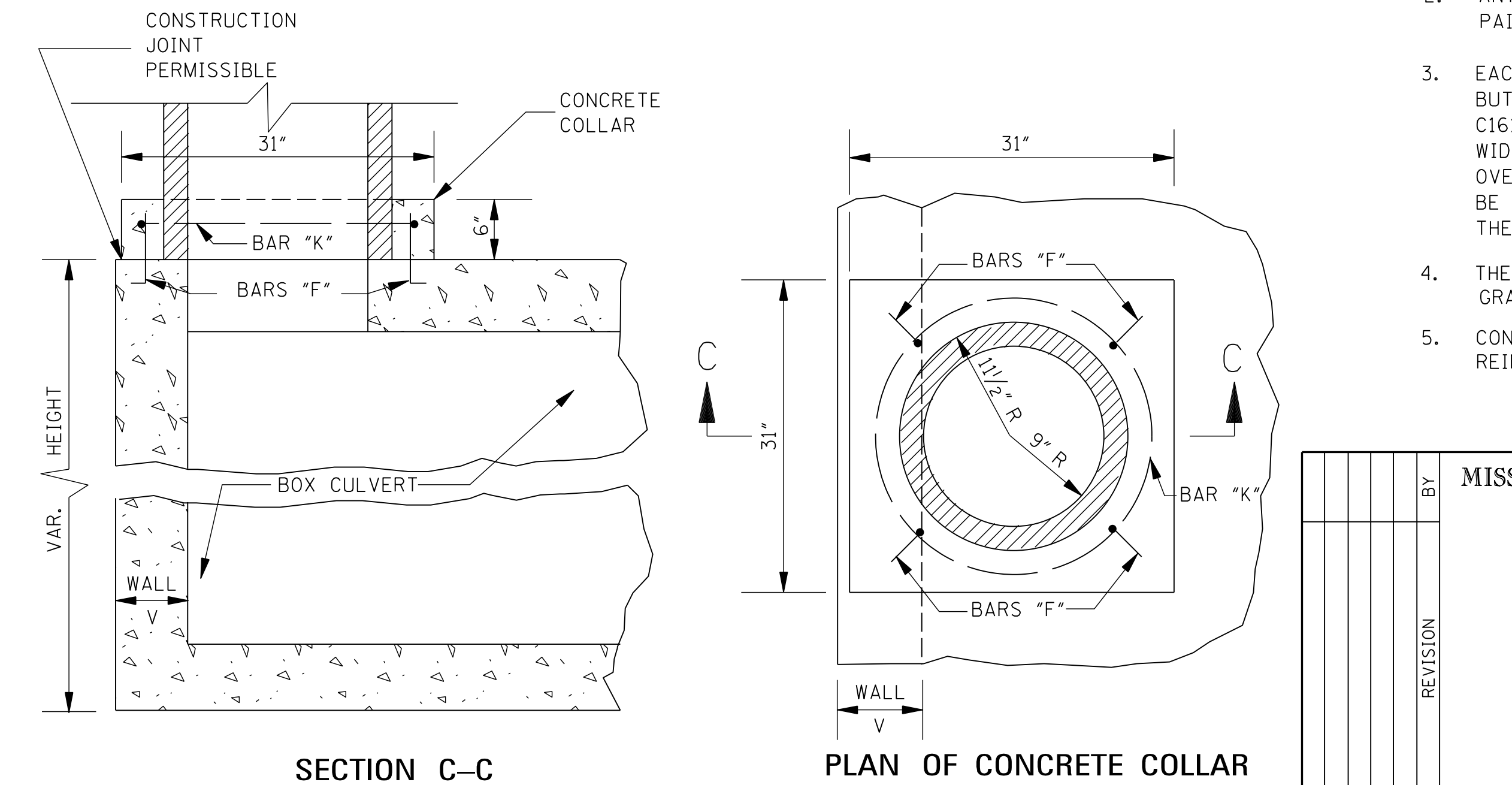
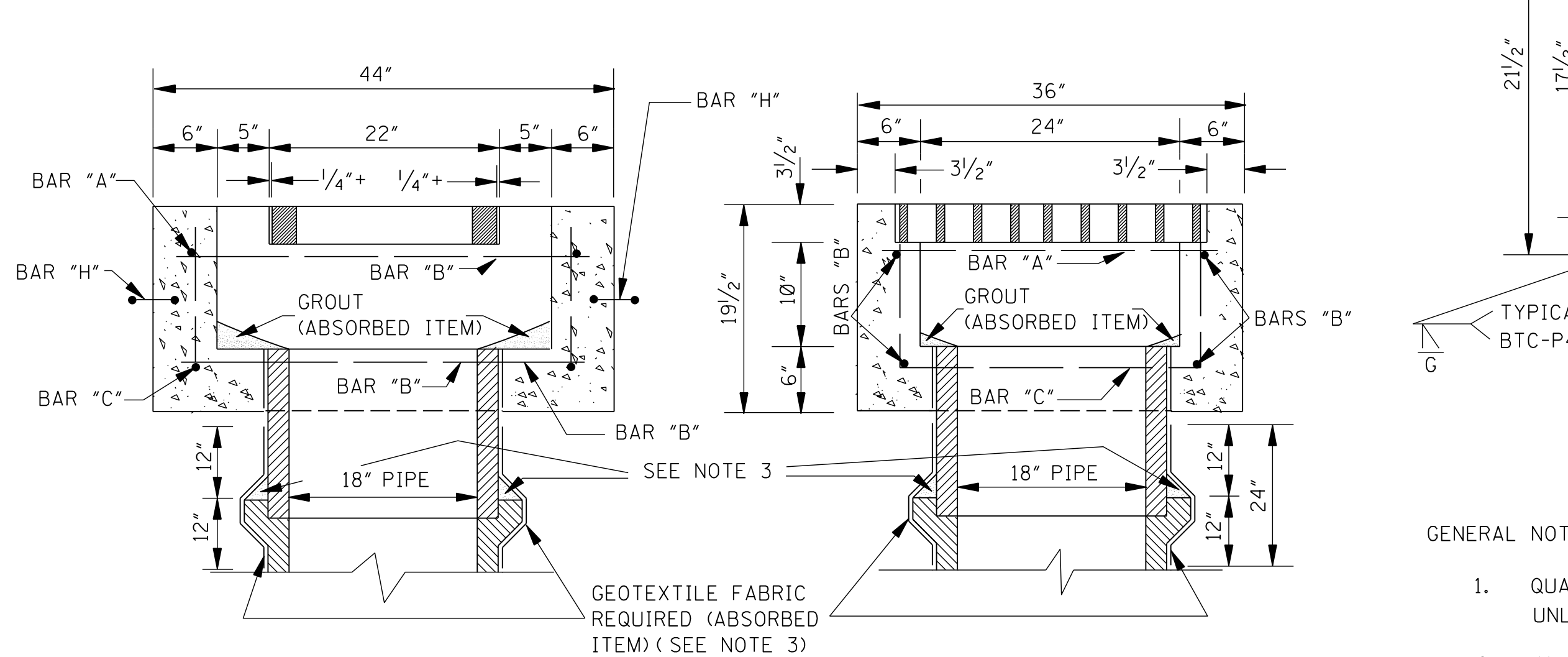
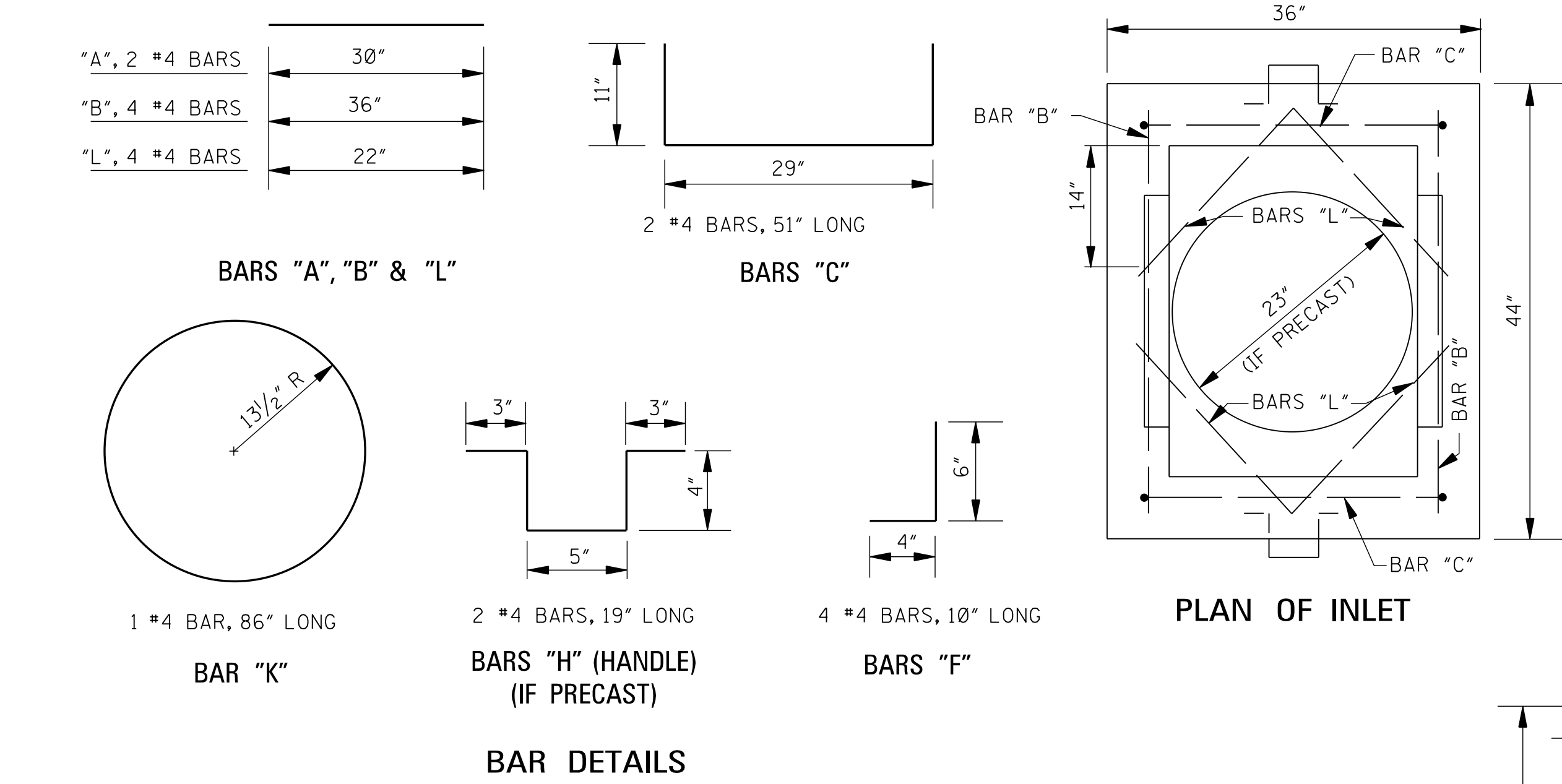

INLET TYPE	CONC. (yd ³)	STEEL (lbs)	EACH ADDED FOOT	
			CONC. (yd ³)	STEEL (lbs)
I	0.097*	18*	0.210	24
II	0.448	30		

*NOTE: 6" MINIMUM HEIGHT INLET WITH AN ASSUMED BOX CULVERT THICKNESS (T) OF 6".

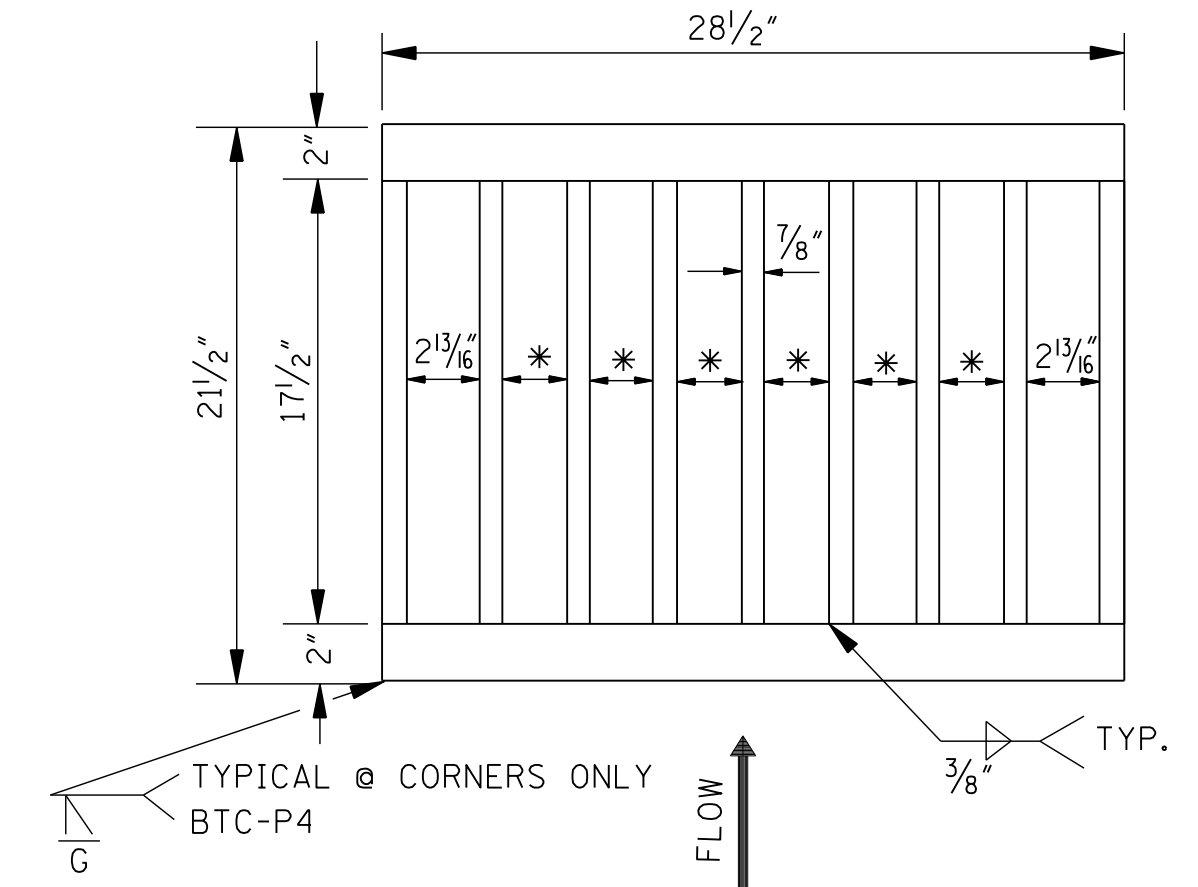

- GENERAL NOTES:
- QUANTITIES SHOWN WILL BE THE BASIS OF PAYMENT UNLESS AUTHORIZED MODIFICATIONS ARE MADE.
 - ANY STACK PIPE THAT MUST BE CUT OFF WILL BE PAID FOR AT FULL PIPE LENGTH AS THOUGH INSTALLED.
 - EACH STACKED PIPE JOINT SHALL BE SEALED WITH BUTYL PER C990 OR RUBBER GASKET PER C443 AND C1619, THEN WRAPPED WITH GEOTEXTILE FABRIC, 24" WIDE, AASHTO M 288 EOS= 100+. THE FABRIC SHALL OVERLAP A MINIMUM OF 12" AT THE WRAP AND SHALL BE SECURED WITH STRING OR WIRE FOR BACKFILLING. THE COST SHALL BE ABSORBED IN OTHERS ITEMS BID.
 - THE CONTRACTOR HAS THE OPTION TO PROVIDE GRATE NO. 1 OR GRATE NO. 2 AS SHOWN ON SHEET IG-1.
 - CONCRETE SHALL BE CLASS "B" CONCRETE AND REINFORCING STEEL SHALL BE DEFORMED BARS.

BY	MISSISSIPPI DEPARTMENT OF TRANSPORTATION ROADWAY DESIGN DIVISION STANDARD PLAN
REVISION	MEDIAN INLETS FOR BOX CULVERTS (TYPE I AND II)
DATE	ISSUE DATE: AUGUST 01, 2017

MDOT
WORKING NUMBER MI-3
SHEET NUMBER 6513

GRATE NO. 1

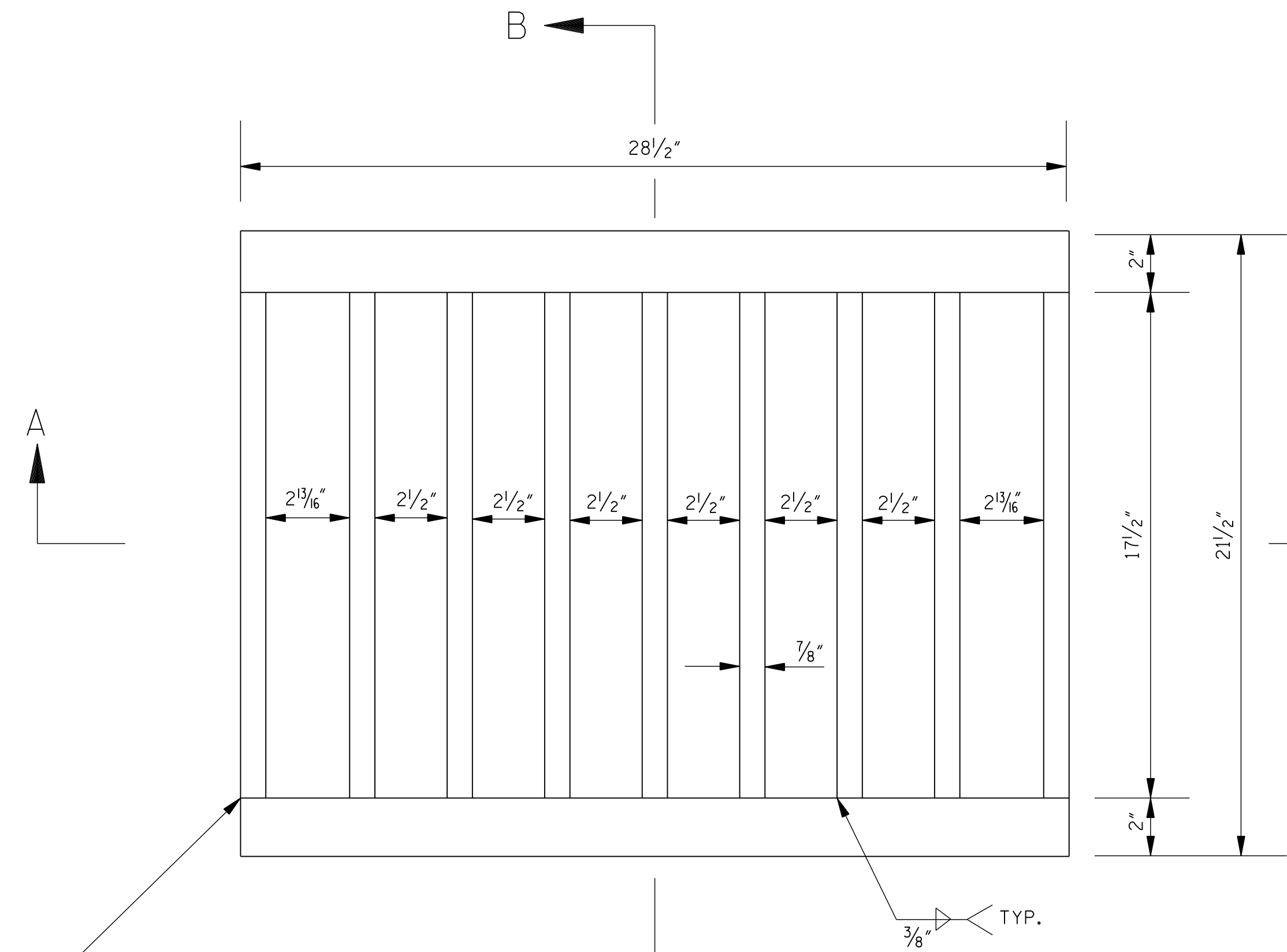

PLAN OF GRATE NO. 1

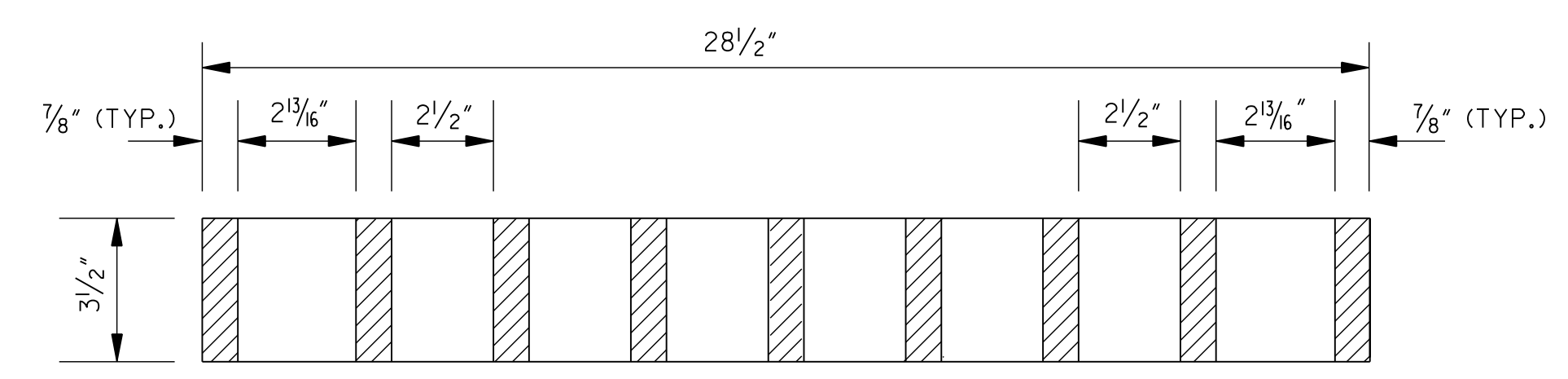

SECTION A-A

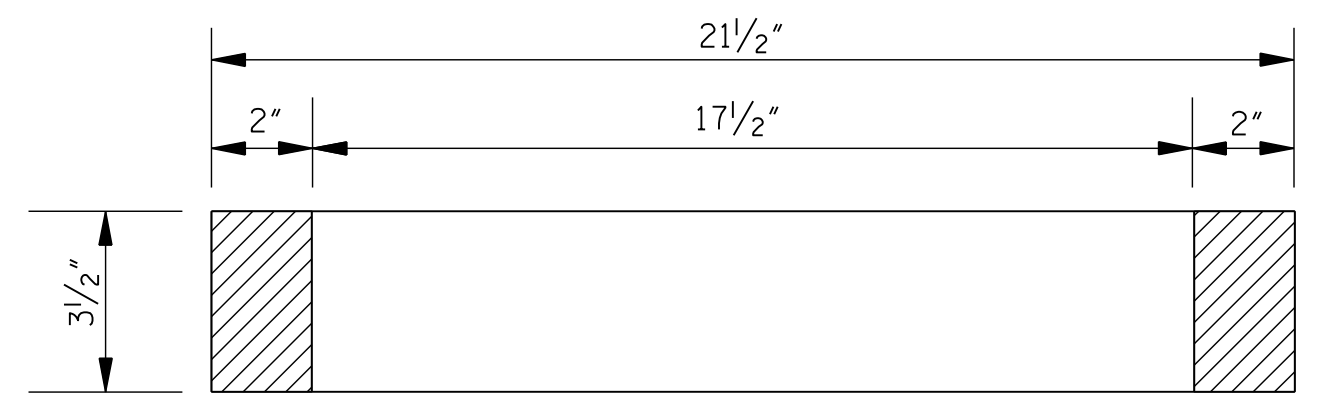

SECTION B-B

GRATE NO. 2

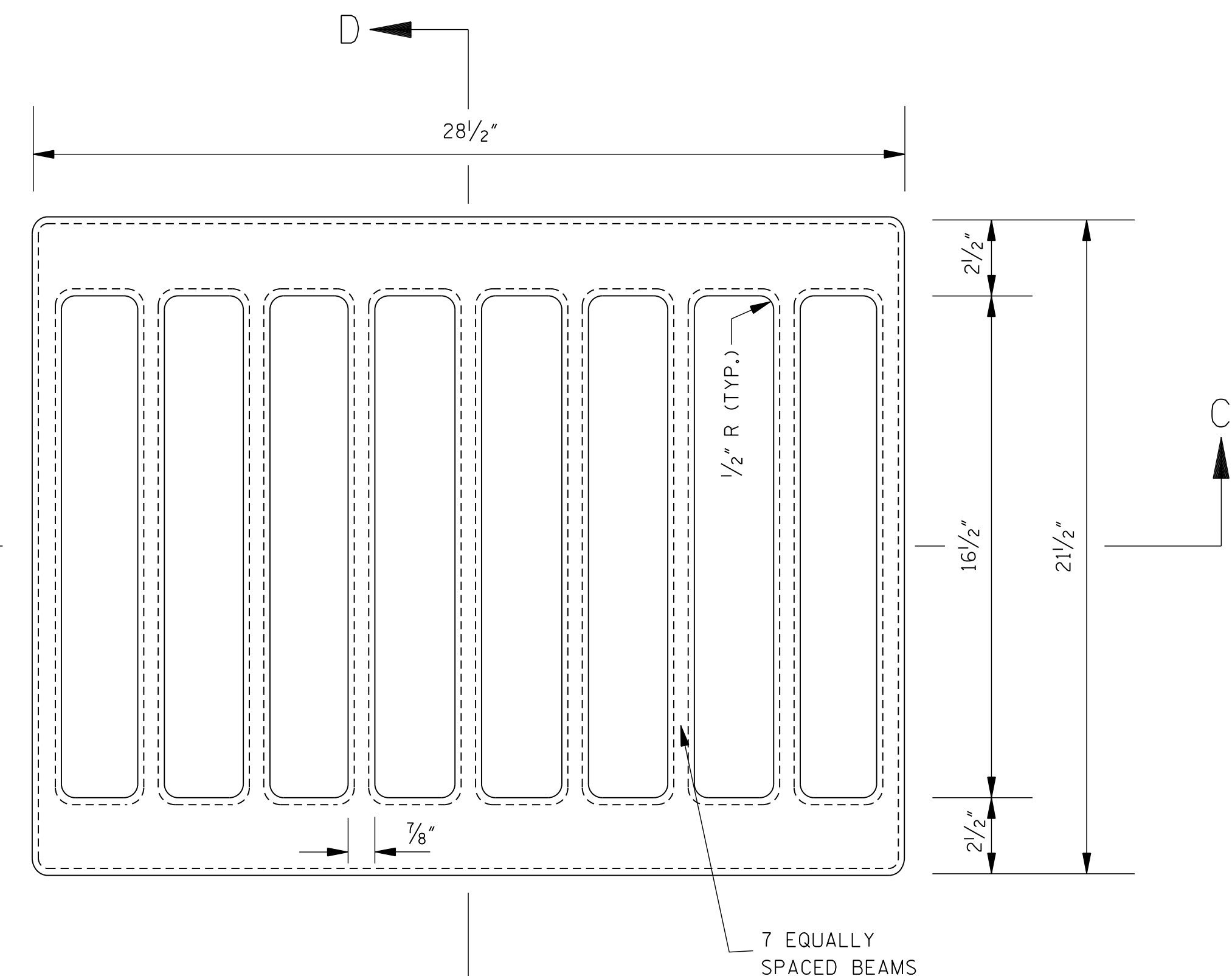

PLAN OF GRATE NO. 2

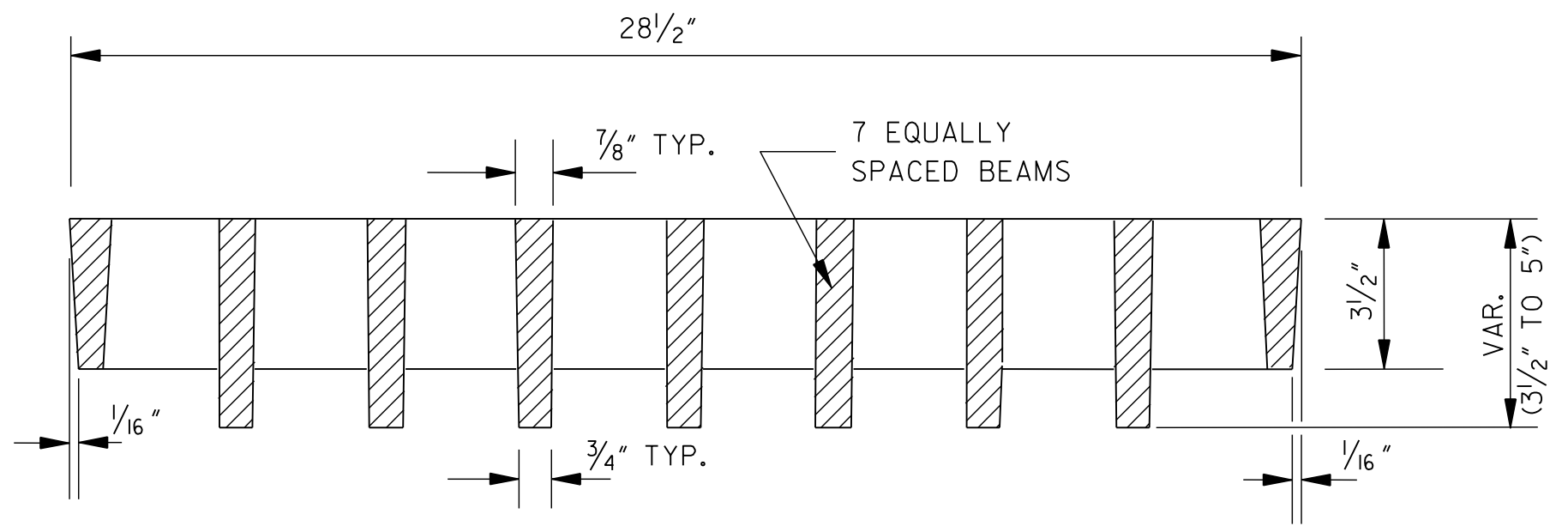

SECTION C-C

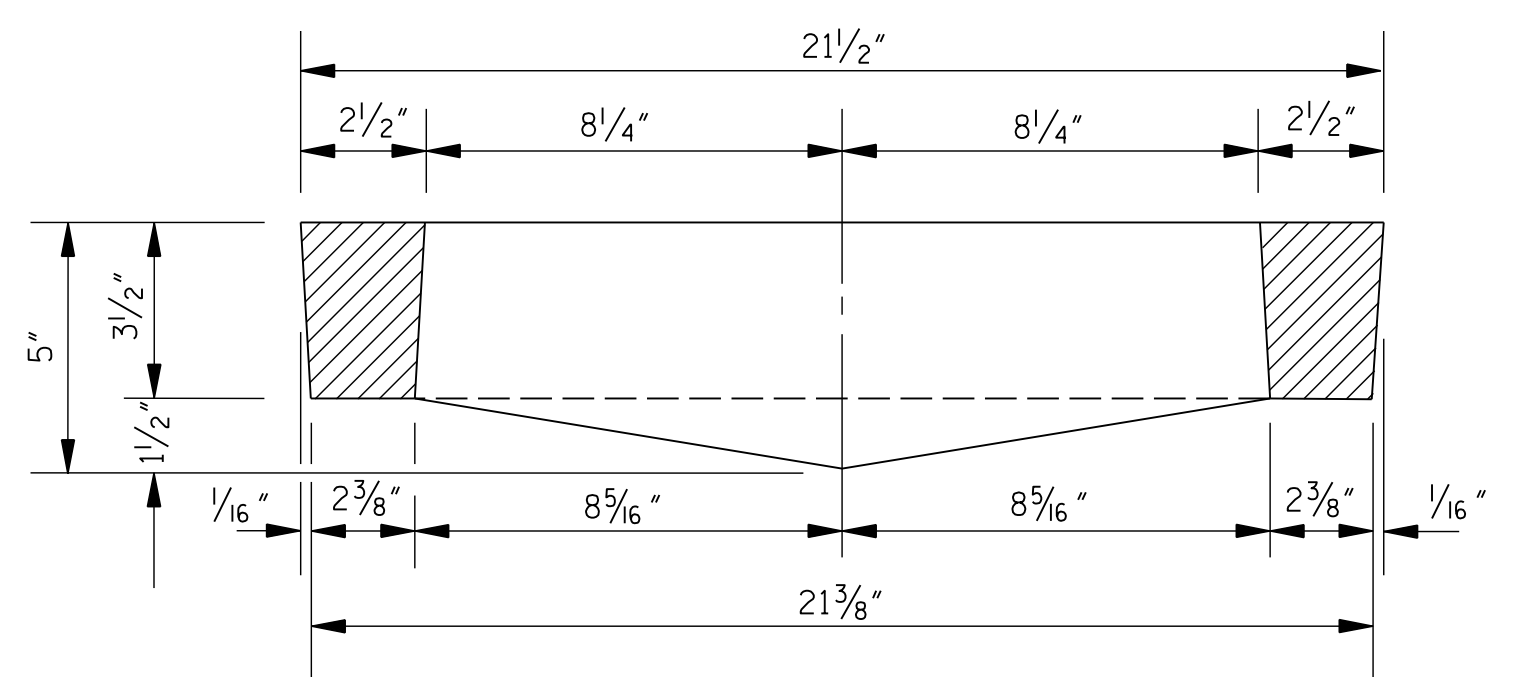

SECTION D-D

GENERAL NOTES:

1. BASIS OF PAYMENT WILL BE 250 lbs OF GRATING FOR EITHER GRATE.
2. GRATE NO.1
THE GRATE SHALL BE WELDED STEEL (ASTM A 588).
3. GRATE NO.2
THE GRATE SHALL BE DUCTILE IRON (ASTM A 536, GRADE 80-55-06).

BY		MISSISSIPPI DEPARTMENT OF TRANSPORTATION ROADWAY DESIGN DIVISION STANDARD PLAN	
REVISION		<p>DETAILS OF GRATES FOR MEDIAN INLETS</p> 	
DATE			
ISSUE DATE: AUGUST 01, 2017		WORKING NUMBER IG-1	SHEET NUMBER 6516

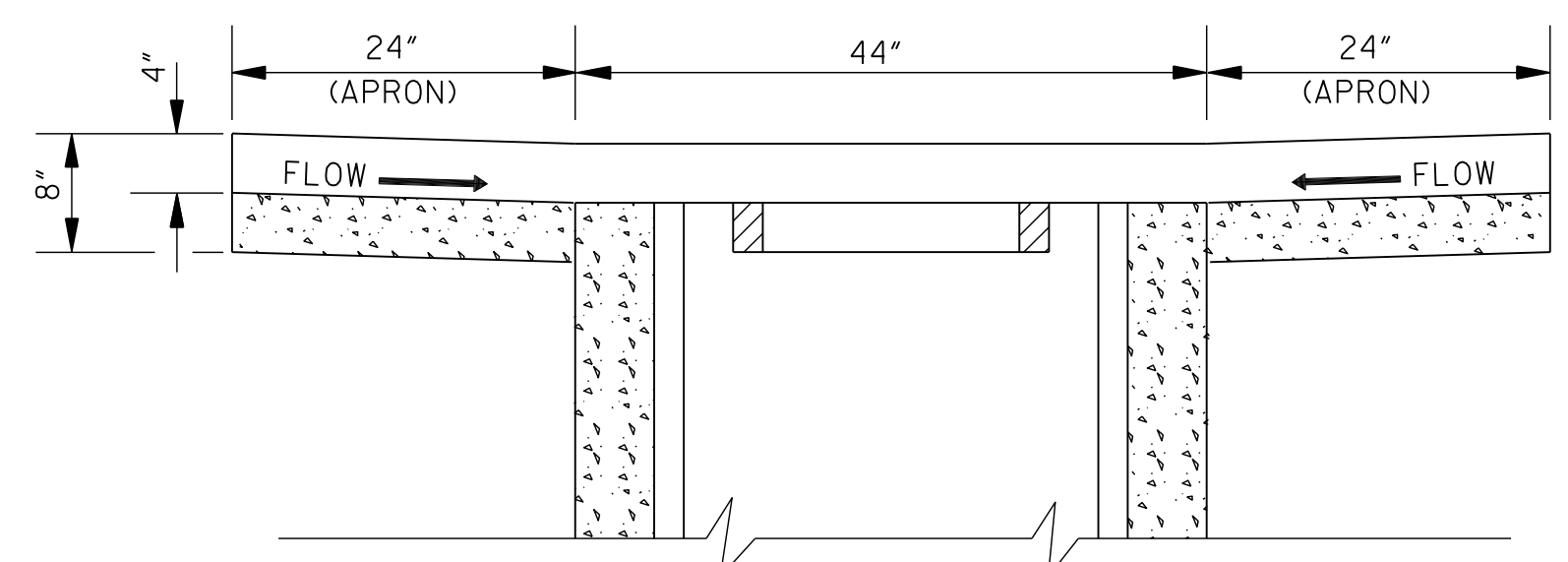

SECTION A-A
NOTE: APRON REINFORCEMENT & SOLID SOD NOT SHOWN (SEE SECTION C-C).

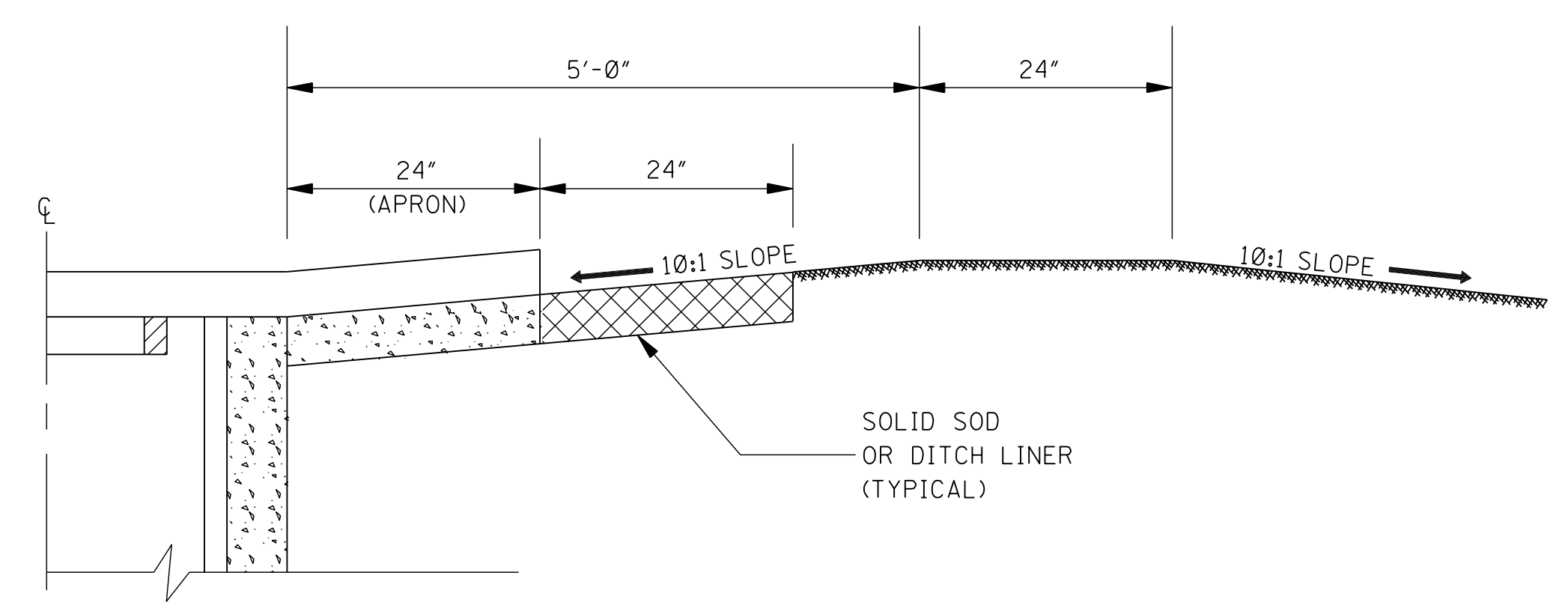

HALF SECTION A-A SHOWING DITCH PLUG

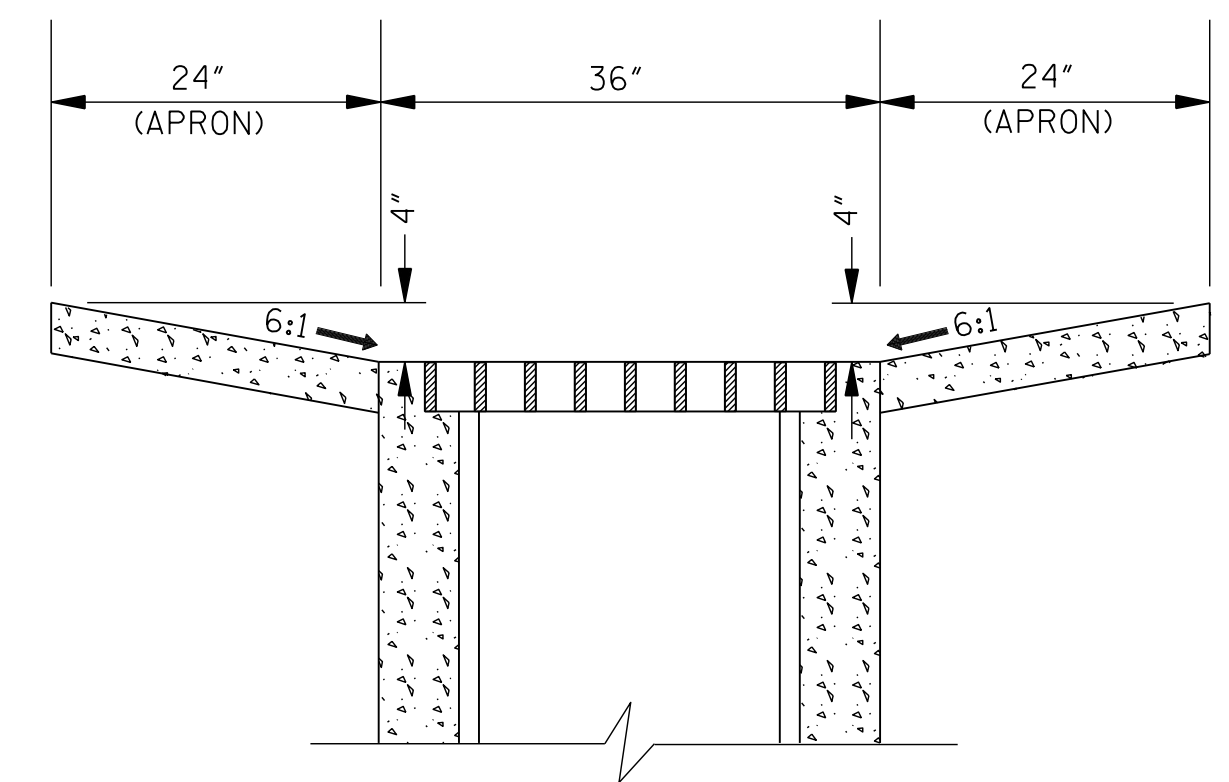

SECTION B-B
NOTE: APRON REINFORCEMENT & SOLID SOD NOT SHOWN (SEE SECTION C-C).

TYPICAL #4 BARS, 30" LONG, SPACED 18" ON CENTER (REQUIRED WHERE PAVED DITCH IS USED. NOT A PAY ITEM).

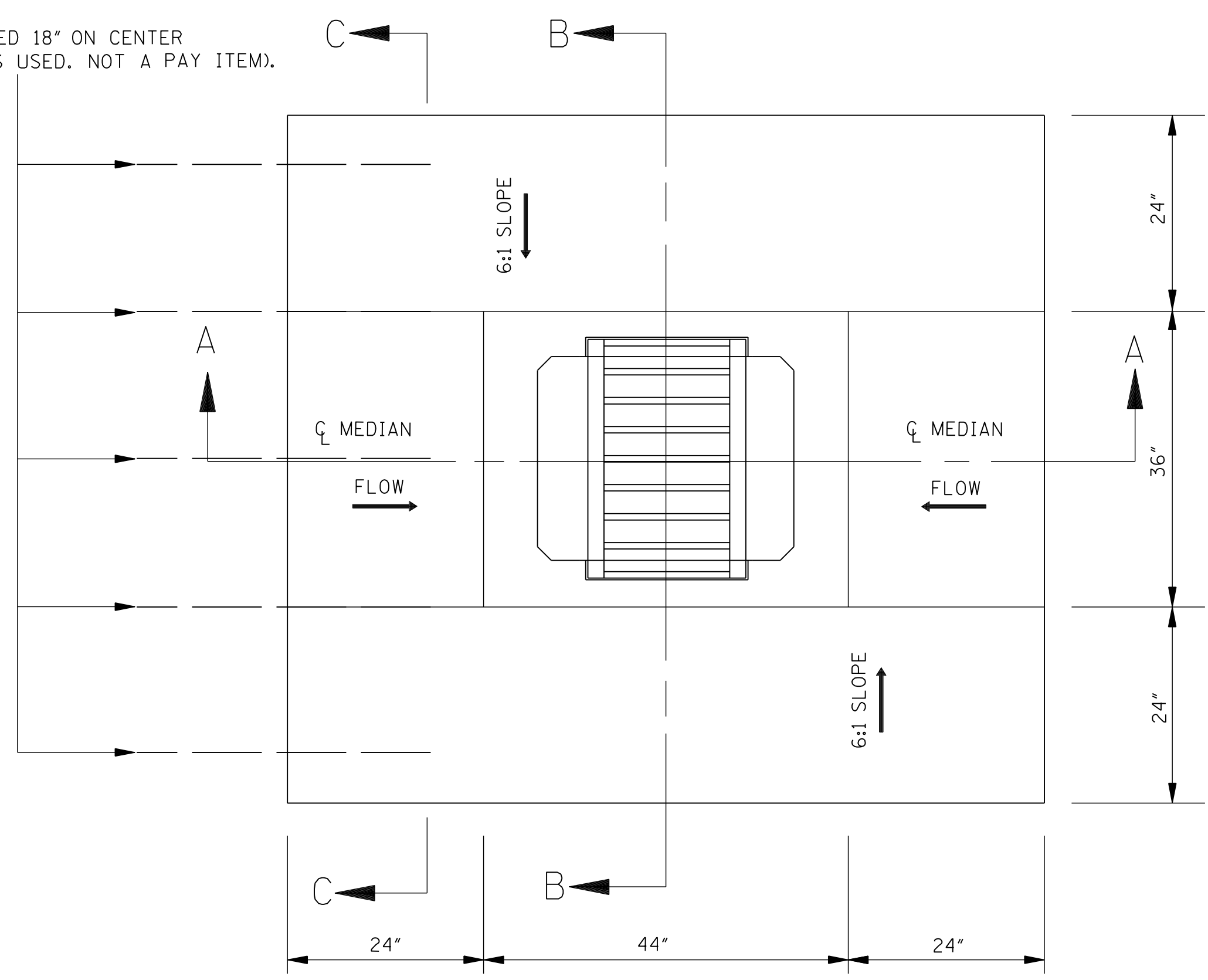

PLAN OF INLET & PAVED APRON

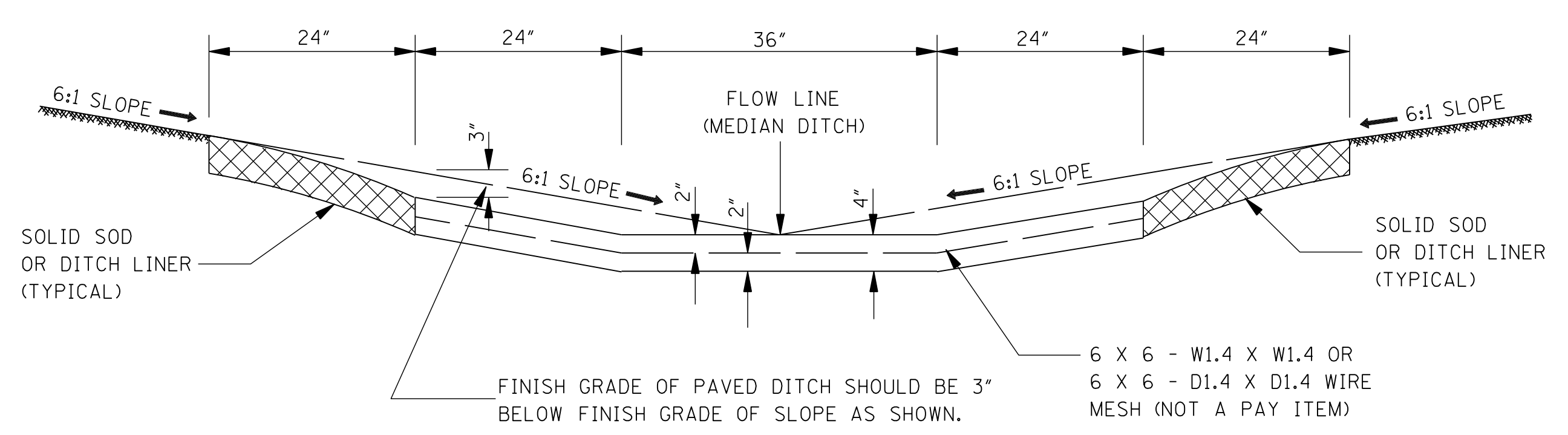

SECTION C-C

GENERAL NOTES:

1. CONSTRUCTION JOINTS TO BE TIED WITH 5 #4 BARS, 30" LONG, SPACED 18" ON CENTER. EXPANSION JOINT WILL NOT BE USED. CHAIR SUPPORTS FOR THE WIRE MESH WILL NOT BE REQUIRED. HOWEVER, THE CONTRACTOR SHALL PLACE THE WIRE MESH IN A SATISFACTORY AND WORKMANLIKE MANNER TO ENSURE THAT THE FINAL POSITION IS REASONABLY NEAR THE POSITION INDICATED.
2. PAVED APRON TO BE CONSTRUCTED AND PAID FOR IN ACCORDANCE WITH THE REQUIREMENTS FOR PAVED DITCHES.
3. 0.532 yd³ CLASS "C" CONCRETE REQUIRED.
4. QUANTITY SHOWN WILL BE USED AS THE BASIS FOR FINAL PAYMENT UNLESS AUTHORIZED MODIFICATIONS ARE MADE.

FINISH GRADE OF PAVED DITCH SHOULD BE 3" BELOW FINISH GRADE OF SLOPE AS SHOWN.

6 X 6 - W1.4 X W1.4 OR 6 X 6 - D1.4 X D1.4 WIRE MESH (NOT A PAY ITEM)

MISSISSIPPI DEPARTMENT OF TRANSPORTATION ROADWAY DESIGN DIVISION STANDARD PLAN	
PAVED INLET APRON AND MEDIAN DITCH PLUG	
BY	
REVISION	
DATE	ISSUE DATE: AUGUST 01, 2017

 WORKING NUMBER
 PA-1
 SHEET NUMBER
 6520

BELL AND SPIGOT END OPTION

NOTE: BELL-END ON DOWNSTREAM SECTION
SPIGOT-END ON UPSTREAM SECTION.

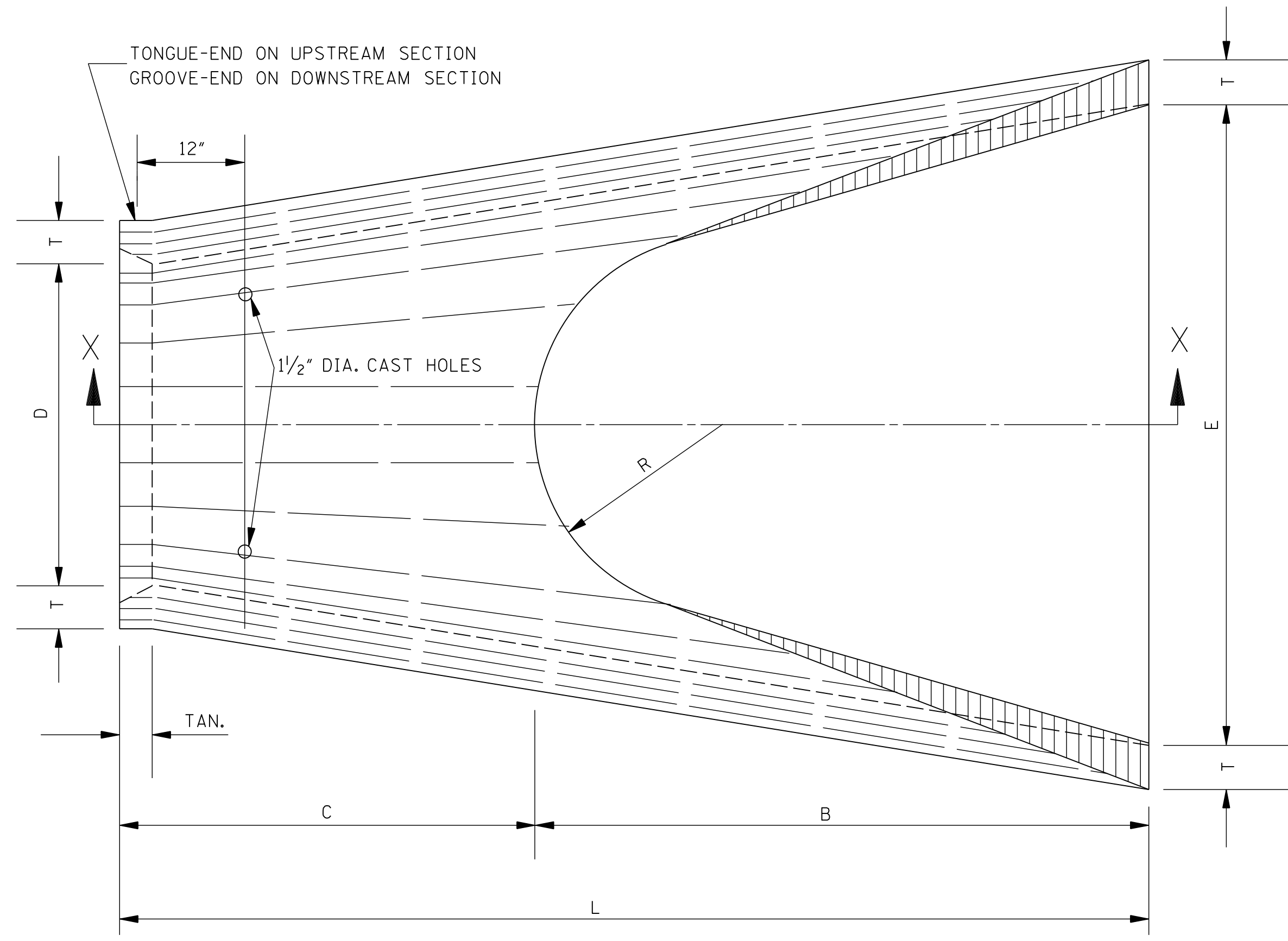

PLAN OF DOWNSTREAM END

D	T	H:V	A	B	C	E	L
15"	2 1/4"	3:1	6"	2'-3"	4'-1"	2'-8"	6'-1"
18"	2 1/2"	3:1	9"	2'-3"	3'-10"	3'-0"	6'-1"
24"	3"	3:1	10"	3'-8"	2'-6"	4'-0"	6'-2"
30"	3 1/2"	3:1	1'-0"	4'-6"	1'-8"	5'-0"	6'-2"
36"	4"	3:1	1'-3"	5'-3"	2'-11"	6'-0"	8'-2"
42"	4 1/2"	3:1	1'-9"	5'-3"	2'-11"	6'-6"	8'-2"
48"	5"	3:1	2'-0"	6'-0"	2'-2"	7'-0"	8'-2"
54"	5 1/2"	3:1	2'-4"	6'-6"	1'-10"	7'-6"	8'-4"
* 60"	6"	3:1	2'-10"	6'-6"	1'-10"	8'-0"	8'-4"
* 66"	6 1/2"	3:1	3'-4"	6'-6"	1'-10"	8'-6"	8'-4"
* 72"	7"	3:1	3'-10"	6'-6"	1'-10"	9'-0"	8'-4"

0.056
0.063
0.083
0.102
0.123
0.134
0.145
0.156
0.167
0.177
0.188

* NOTE: SEE GENERAL NOTE 2.

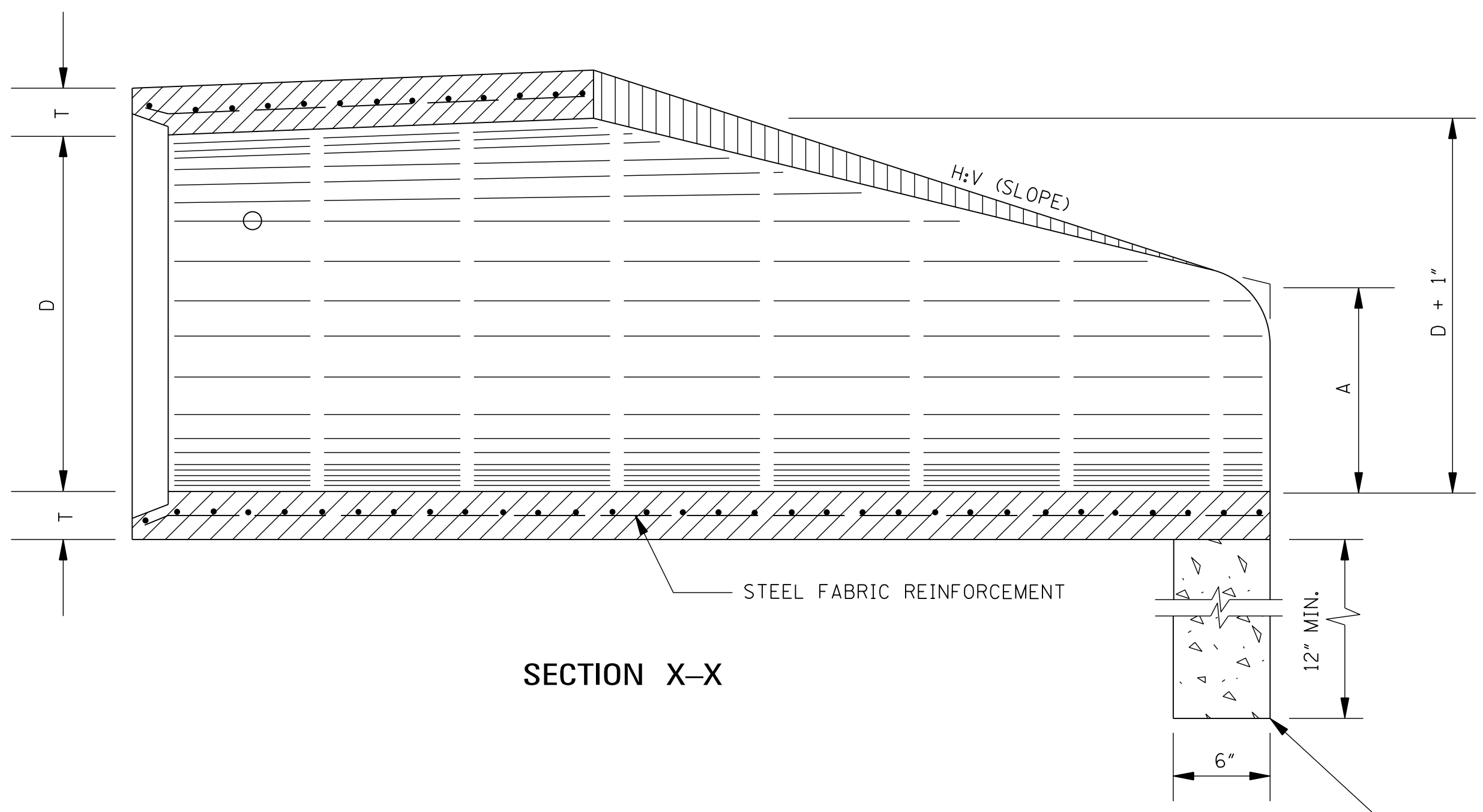

SECTION X-X

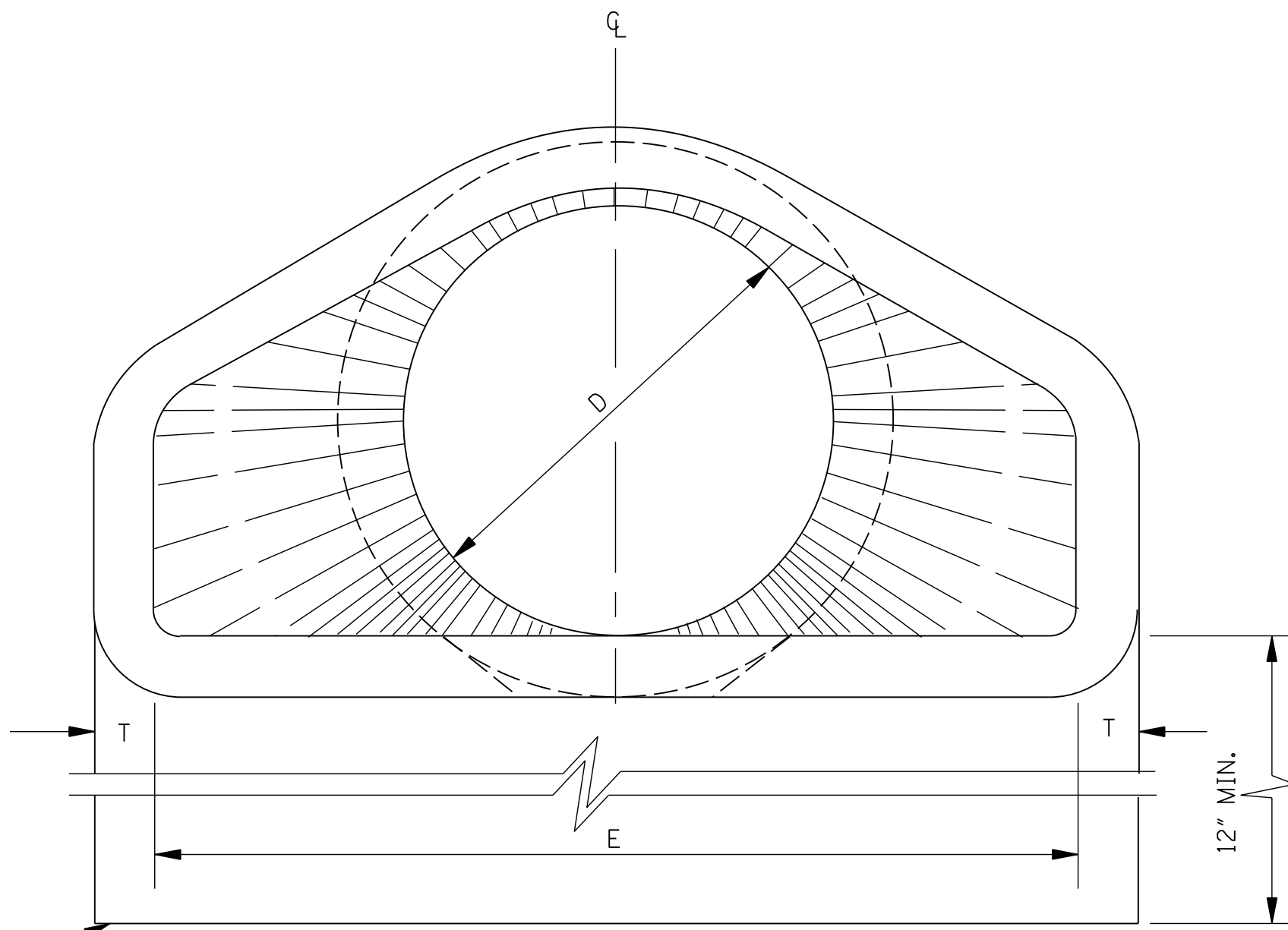

END ELEVATION

TOE WALL REQUIRED ON ALL FLARED END SECTIONS. TO BE PAID FOR AS CLASS "B" STRUCTURAL CONCRETE - MINOR STRUCTURES.

GENERAL NOTES:

- REINFORCEMENT SHALL CONFORM TO THE REQUIREMENTS OF REINFORCED CONCRETE PIPE OF LIKE DIAMETER PER AASHTO M 170, TABLE 2, WALL B.
- 2 - 1 1/2" DIA. CAST HOLES REQUIRED AS SHOWN TO ACCOMMODATE 2 - 1" DIA. TIE BOLTS, USED IN TIEING SECTION TO PIPE CULVERT.
- LENGTH (L) OF A BELL-END OPTION MAY VARY BY A NOMINAL EXTENSION ON THE BELL END.
- FLARED END SECTIONS SHOULD BE REGARDED AS OBSTACLES UNDER THE BELOW CONDITIONS AND AS SUCH SHOULD BE LOCATED OUTSIDE OF THE CLEAR ZONE:
 - CROSS DRAINS WITH SINGLE ROUND PIPES OF DIAMETER GREATER THAN 36" OR EQUIVALENT FOR ARCH PIPES.
 - CROSS DRAINS WITH MULTIPLE ROUND PIPES OF DIAMETER GREATER THAN 30" OR EQUIVALENT FOR ARCH PIPES.
 - PARALLEL SIDE DRAINS WITH SINGLE ROUND PIPES OF DIAMETER GREATER THAN 24" OR EQUIVALENT FOR ARCH PIPES.
- ALL SIZES OF FLARED END SECTIONS FOR CIRCULAR CONCRETE PIPE MAY BE FURNISHED WITH EITHER BELL AND SPIGOT OR TONGUE AND GROOVE ENDS.

BY		MISSISSIPPI DEPARTMENT OF TRANSPORTATION ROADWAY DESIGN DIVISION STANDARD PLAN	
REVISION		<p align="center">FLARED END SECTION FOR CONCRETE PIPE</p> 	
DATE			
ISSUE DATE:		AUGUST 01, 2017	
WORKING NUMBER		FE-1	
SHEET NUMBER		6530	

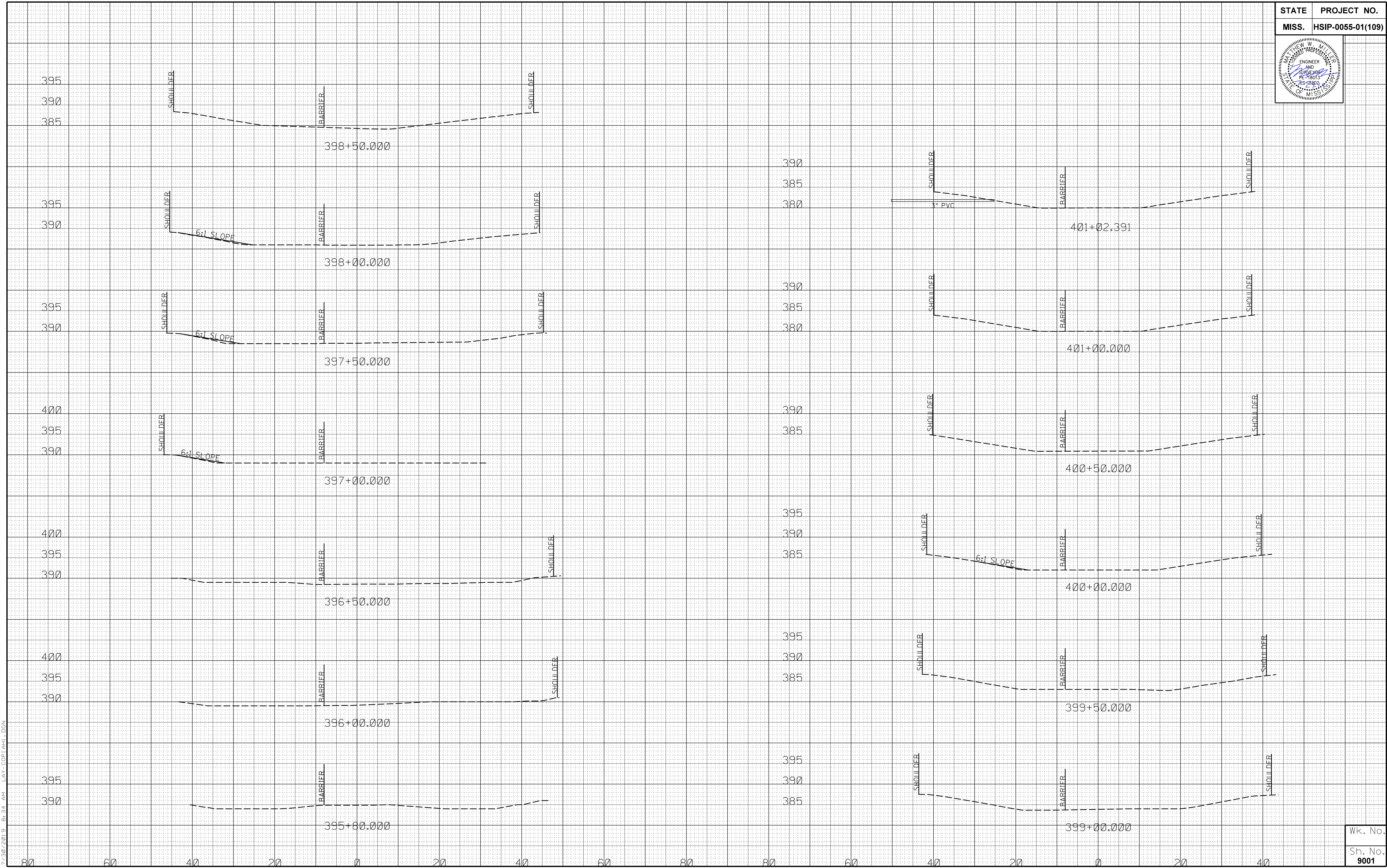
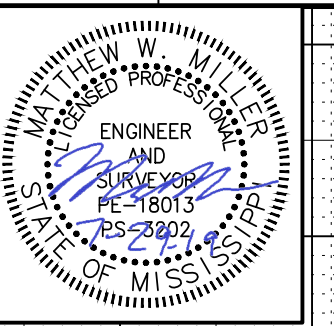

7/30/2019 8:34 AM LAY-COPI.AHI.DGN

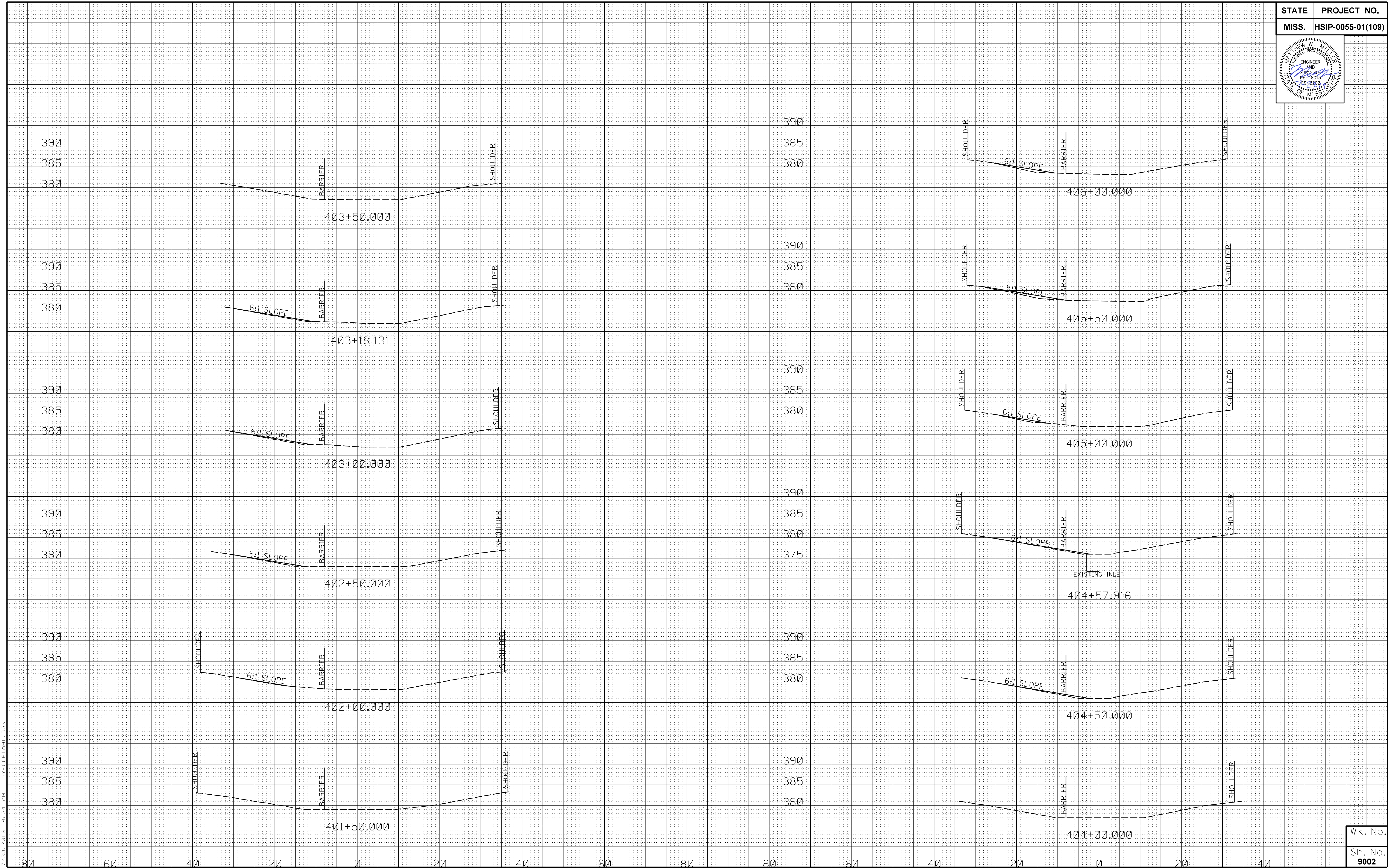
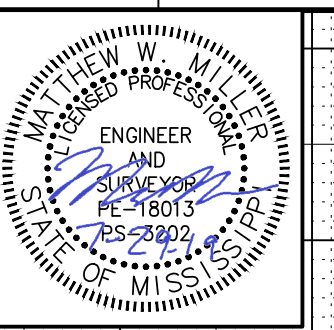

7/30/2019 8:34 AM LAY-COPI.AHI.DGN

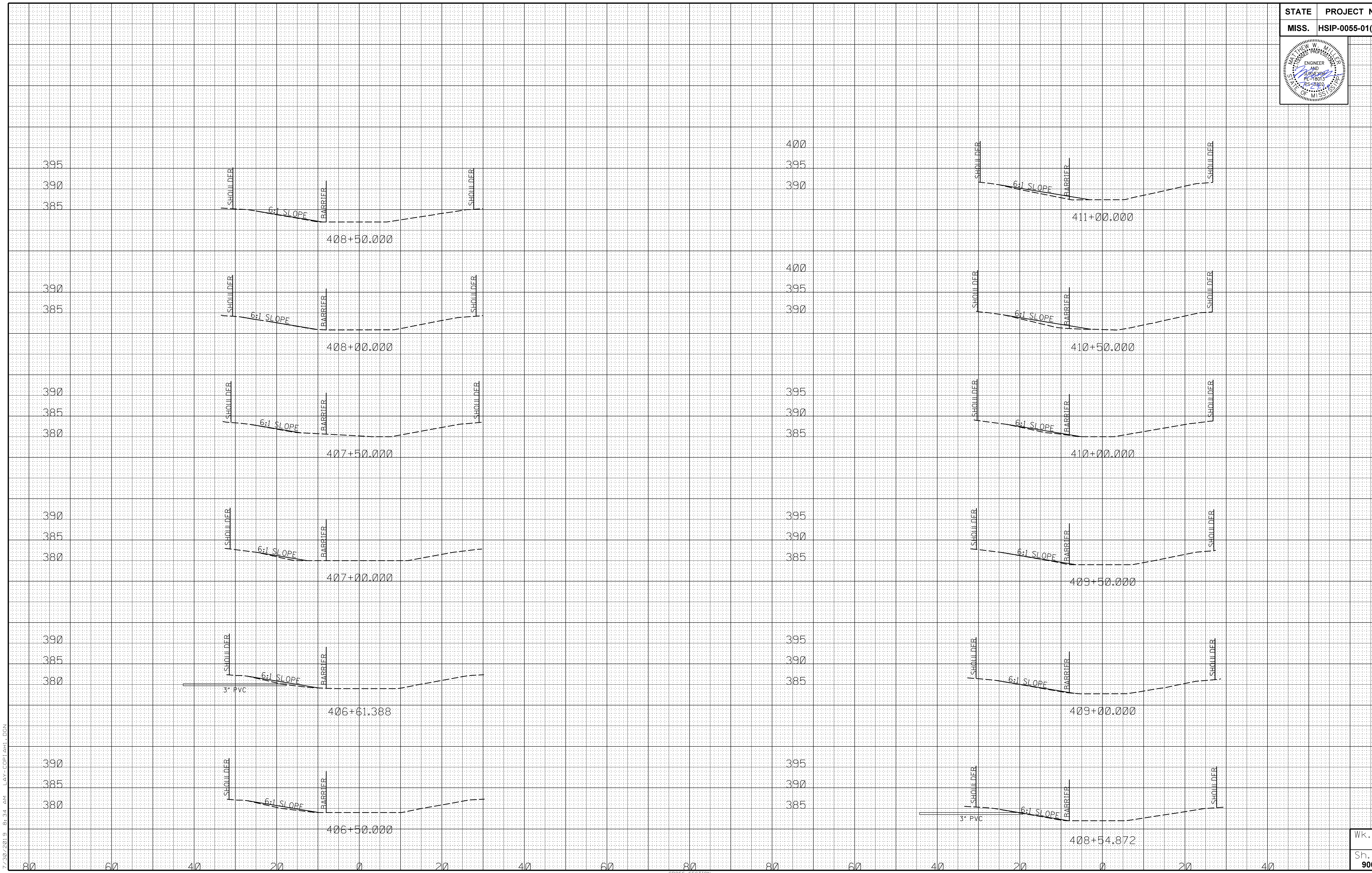
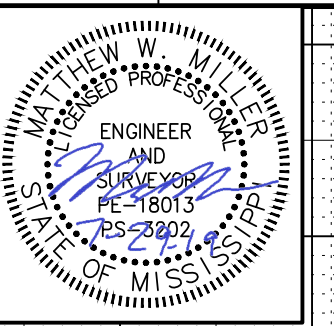

7/30/2019 8:34 AM LAY-COPI.AHI.DGN

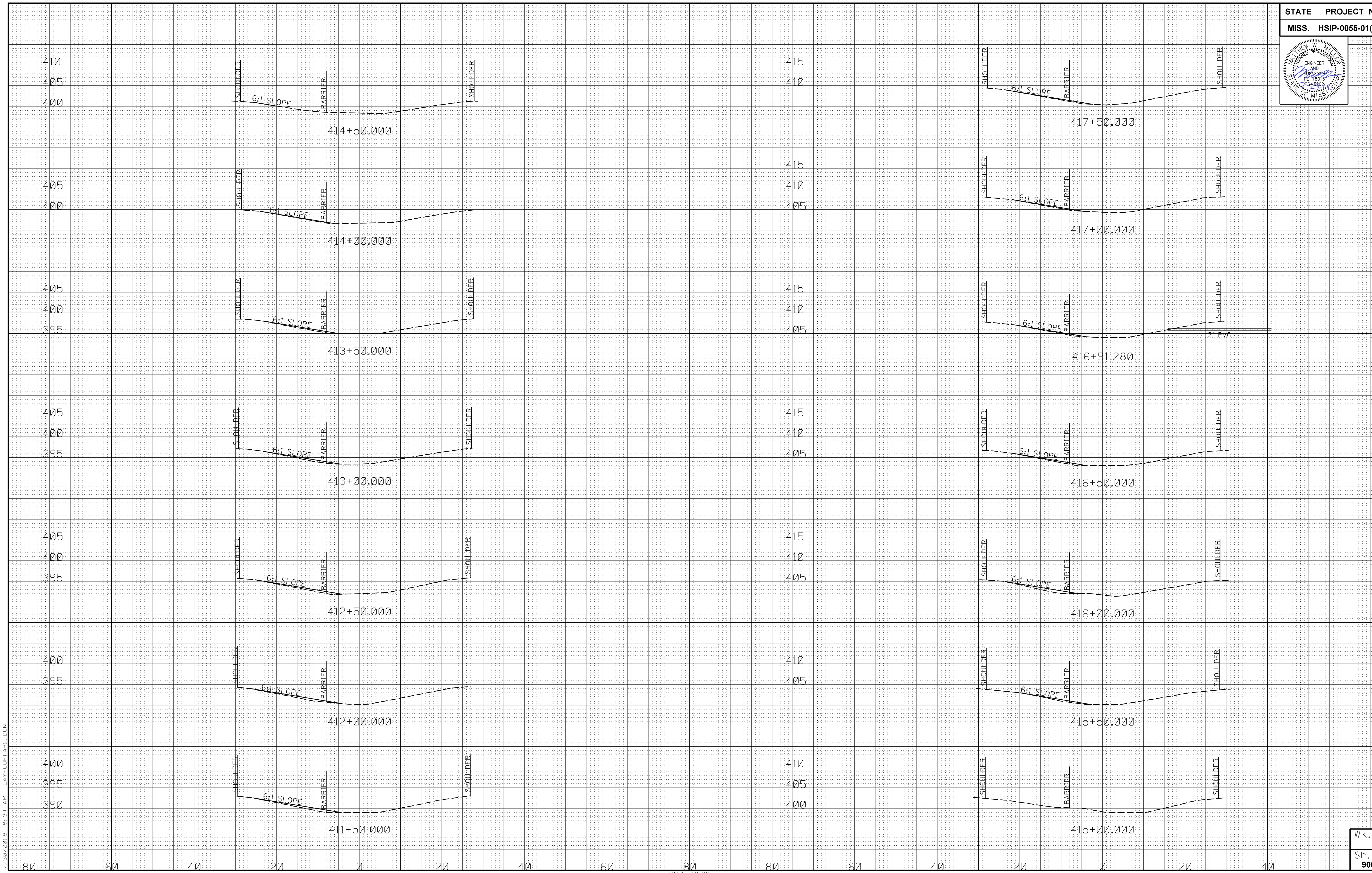
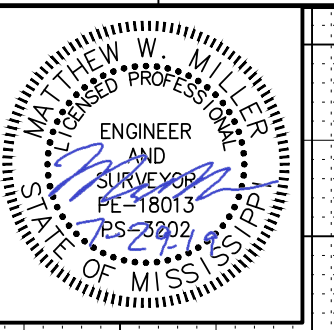

7/30/2019 8:34 AM LAY-COPI.AHI.DGN

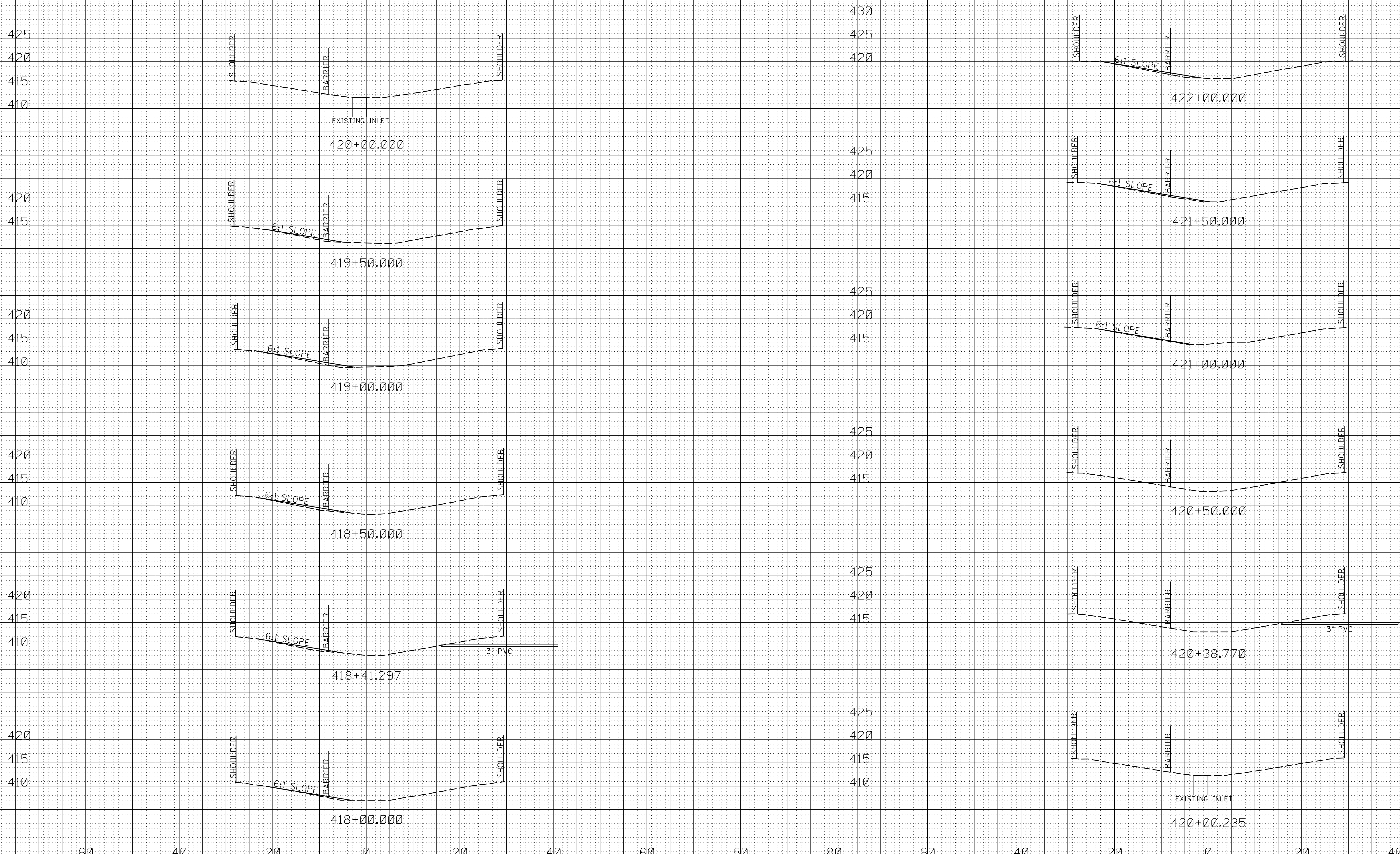
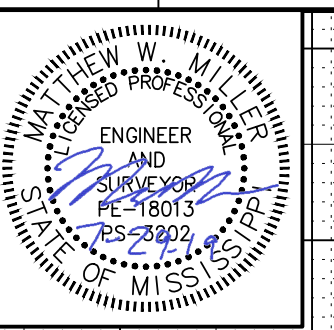

7/30/2019 8:34 AM LAY-COPI.AHI.DGN

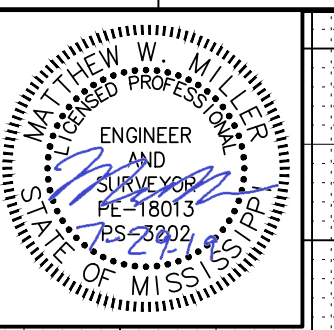

430
425
430
425
420
430
425
420
430
425
420
430
425
420
430
425
420
430
425
420

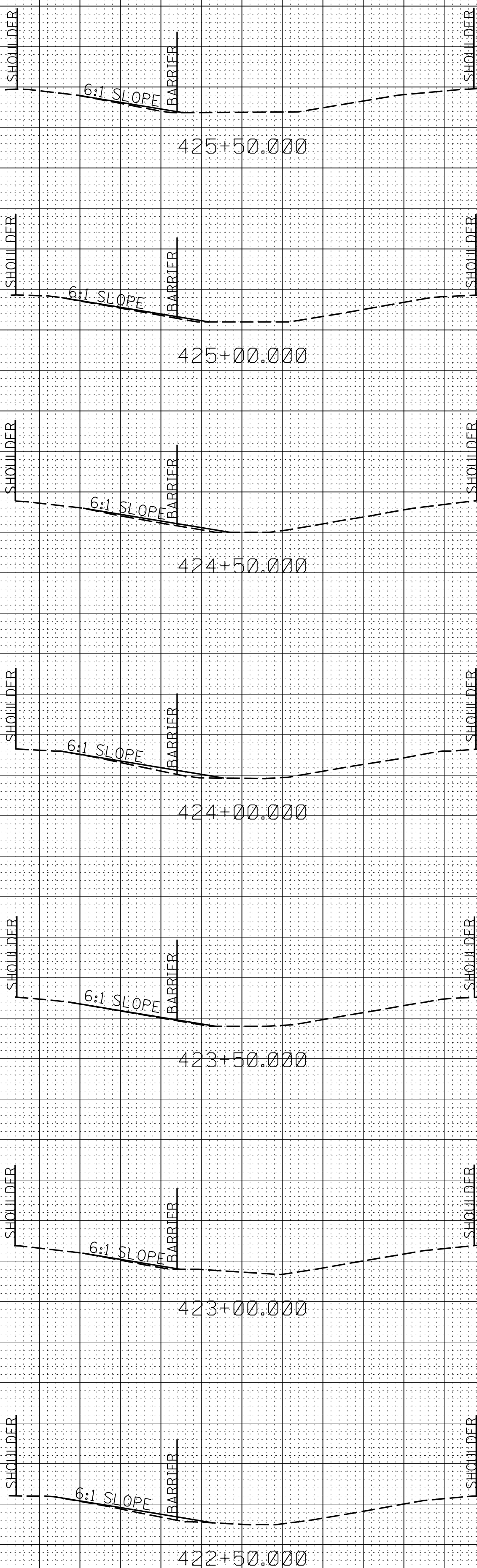

430
425
425
425
430
425
430
425
430
425
430
425
430
425
430
425
430
425
430
425
435
430
425

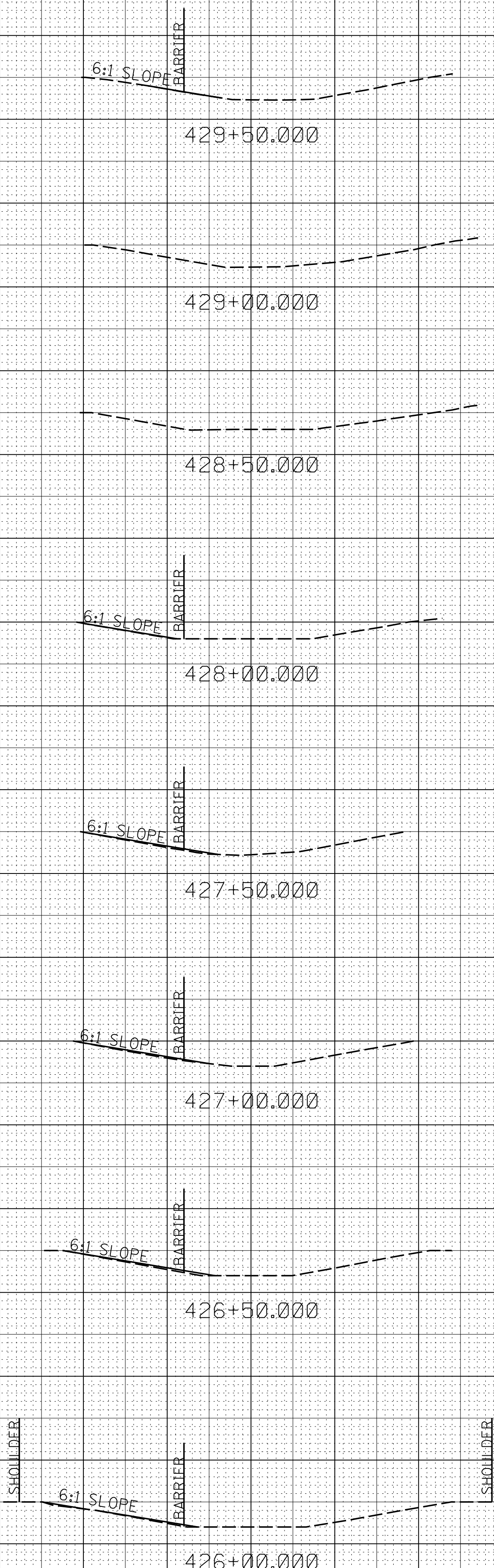

7/30/2019 8:34 AM LAY-COPI.AHI.DGN

80 60 40 20 0 20 40 60 80 80 60 40 20 0 20 40

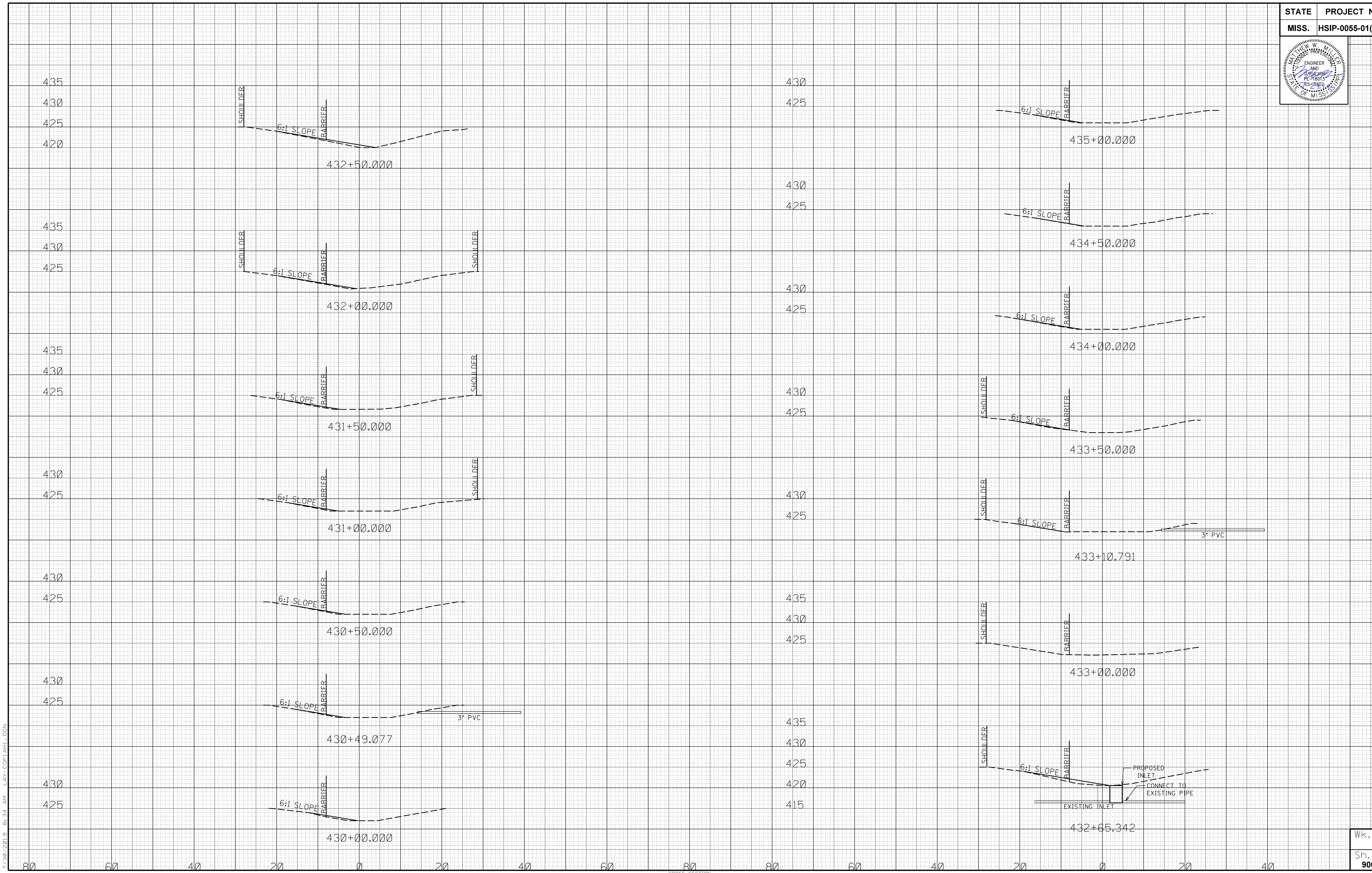
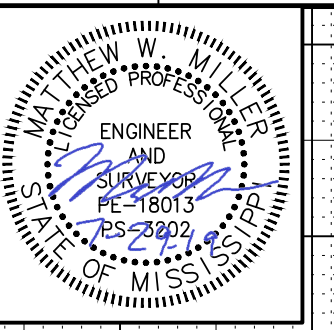

7/30/2019 8:34 AM LAY-COPI.AHI - DGN

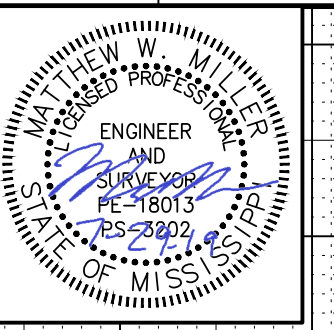

430
425
420

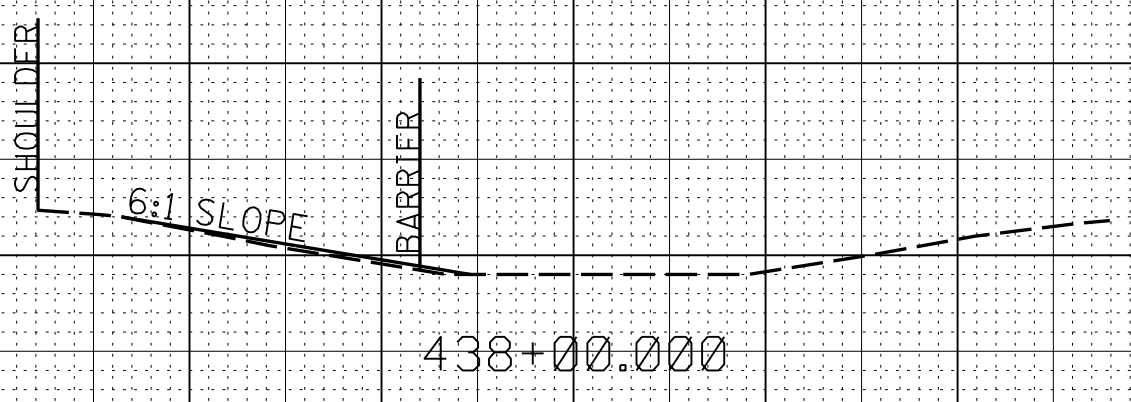

425
420
415

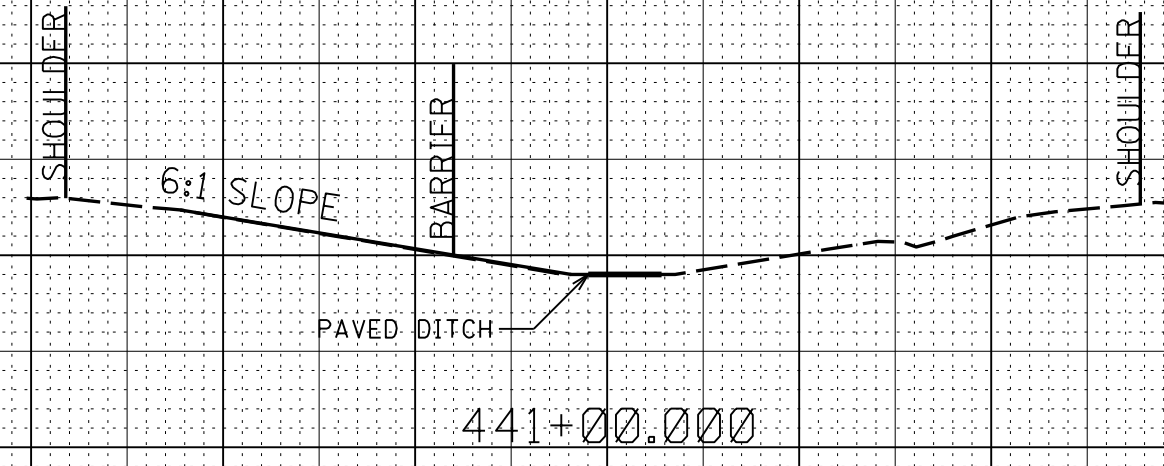

430
425
420

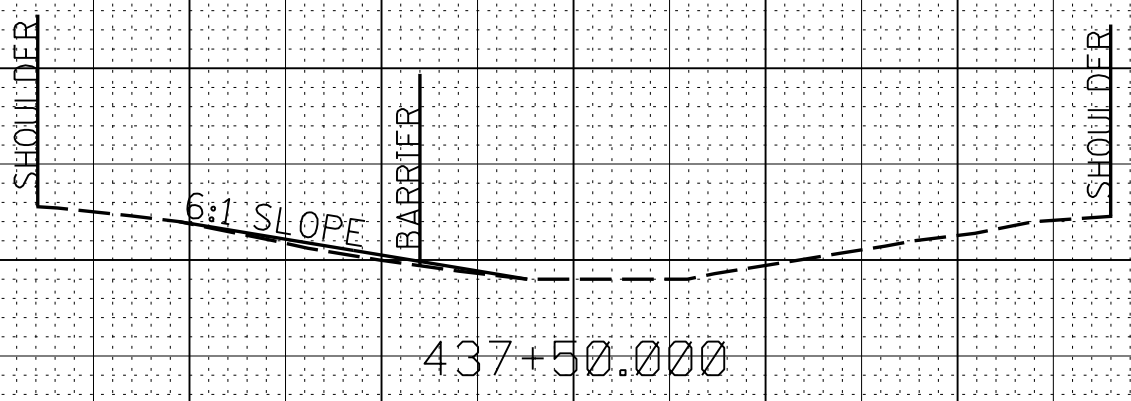

425
420
415

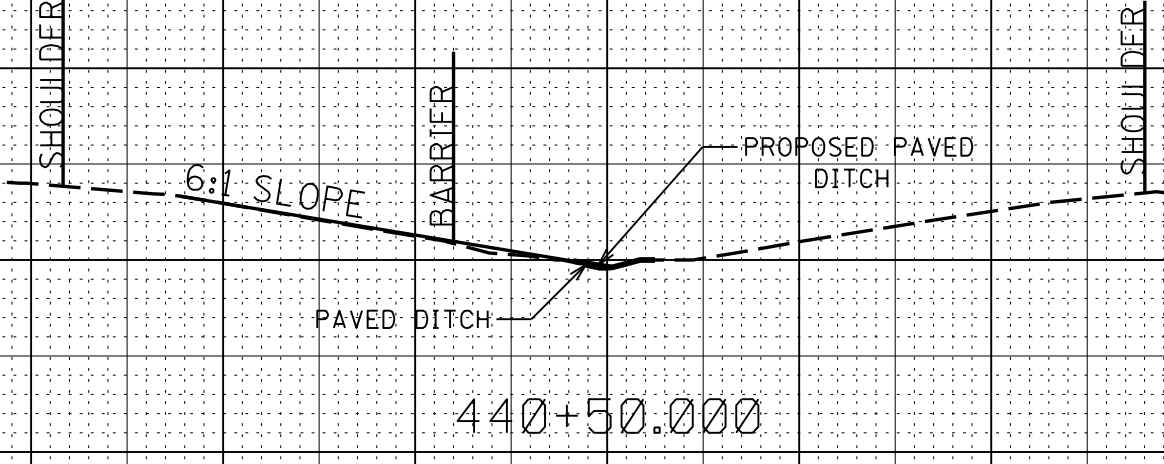

430
425
420

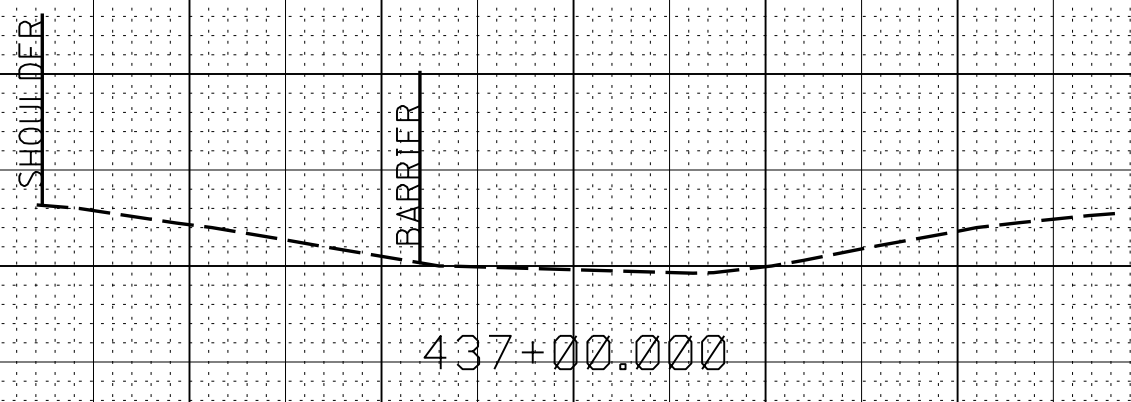

425
420

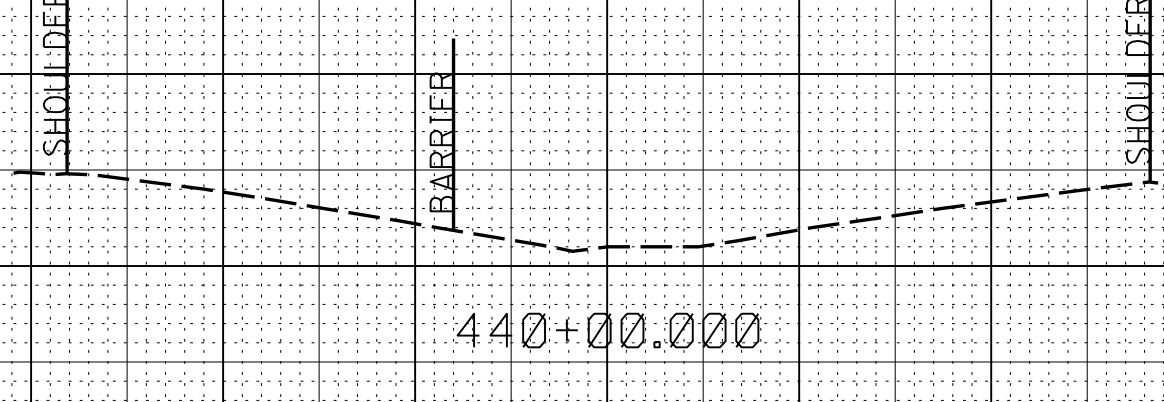

430
425
420

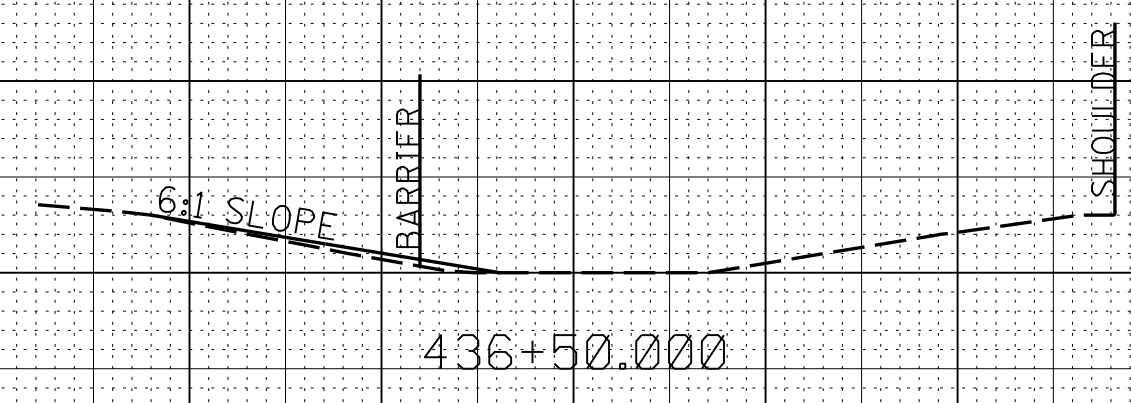

430
425
420

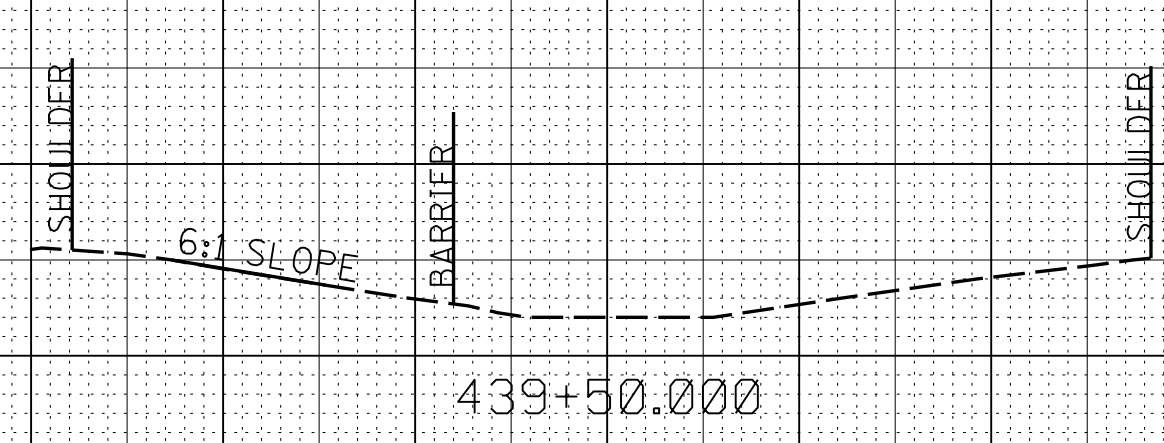

430
425
420

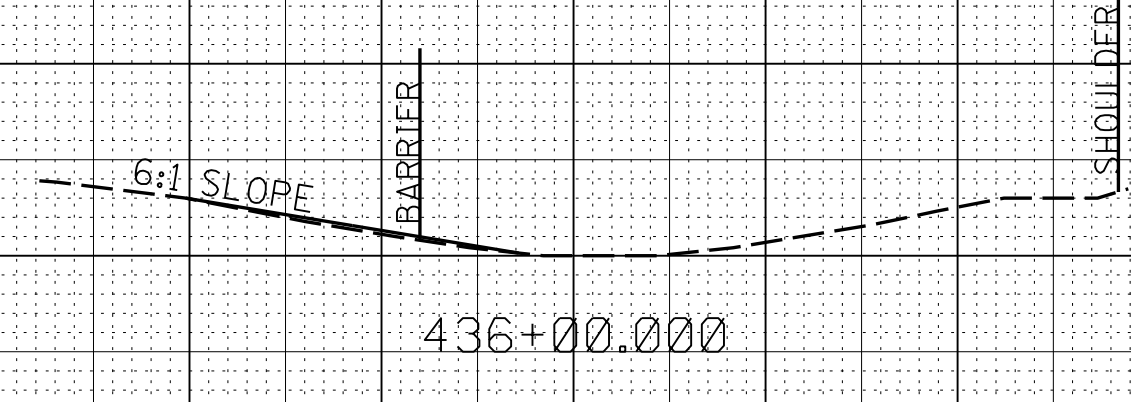

430
425
420

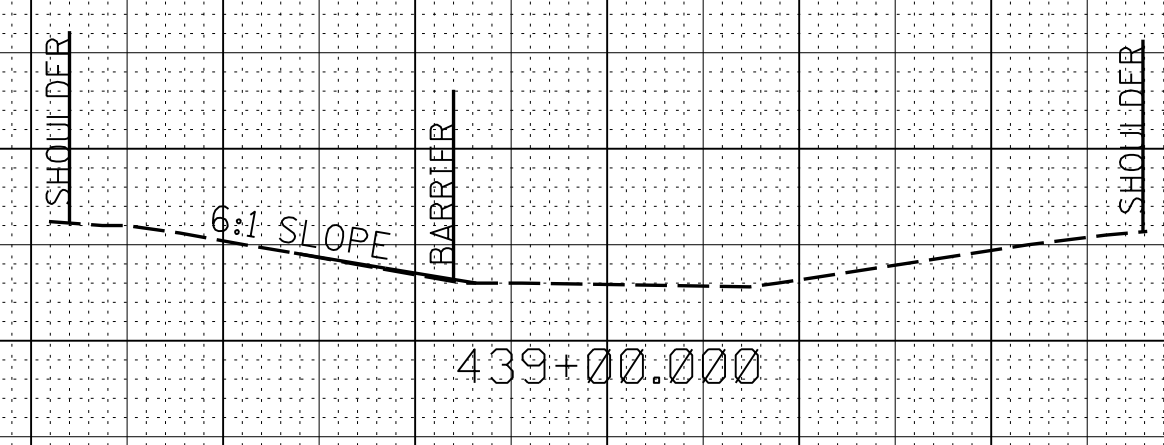

430
425

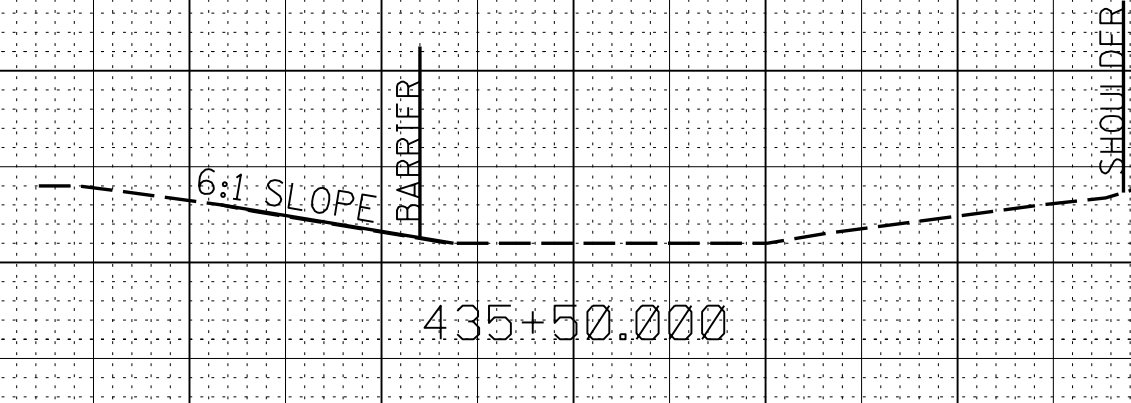

430
425
420

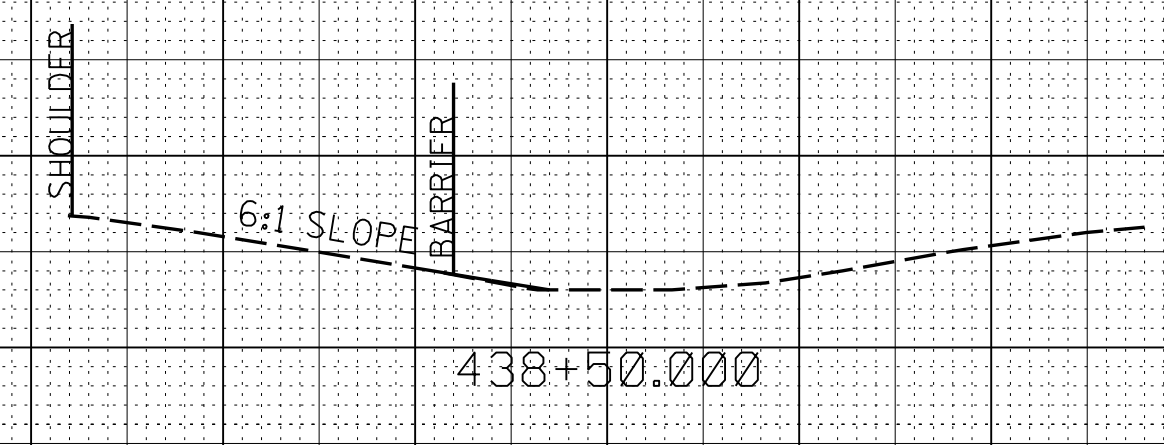

7/30/2019 8:34 AM LAY-COPI.AHI.DGN

80 60 40 20 0 20 40 60 80 80 60 40 20 0 20 40

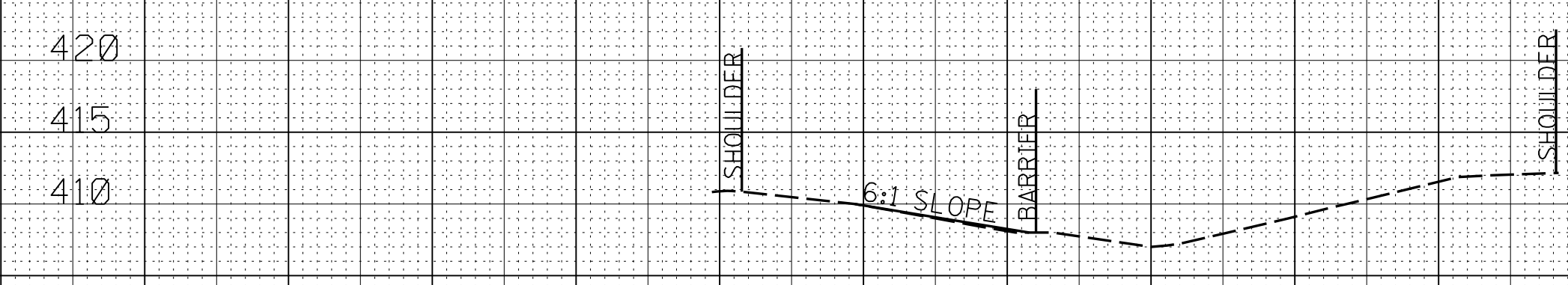
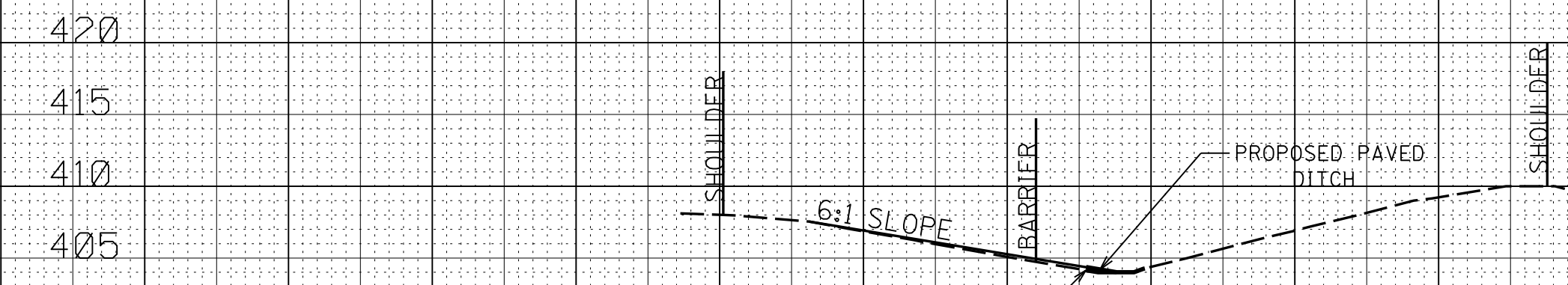
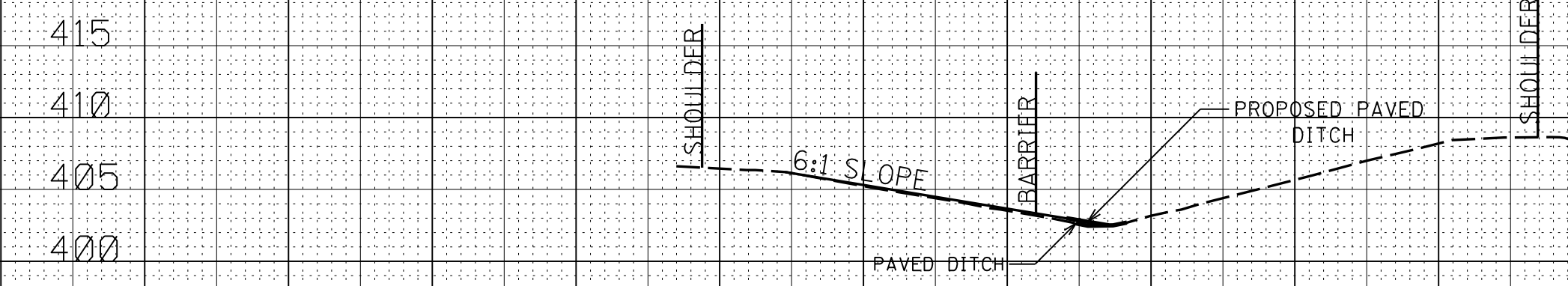
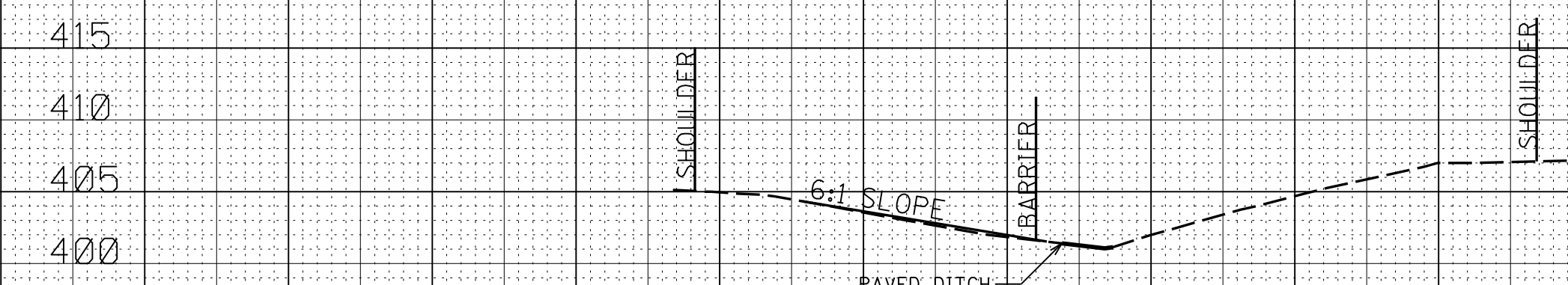
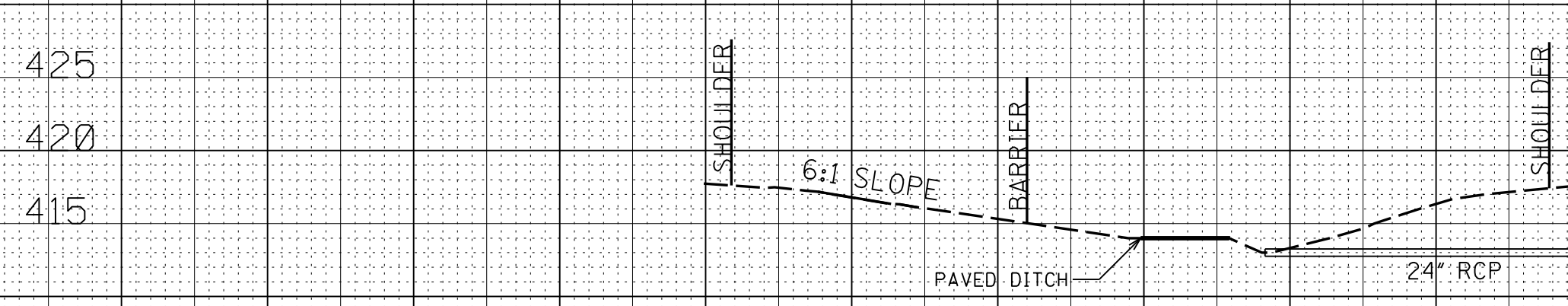
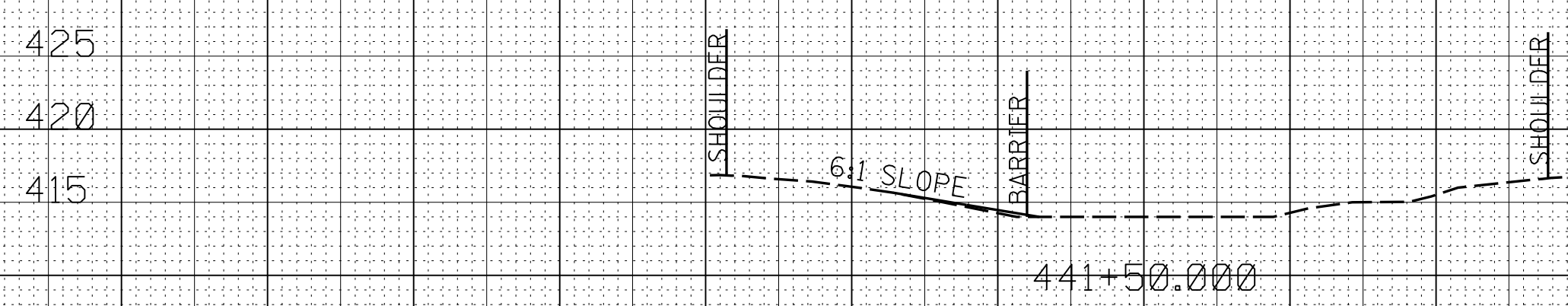
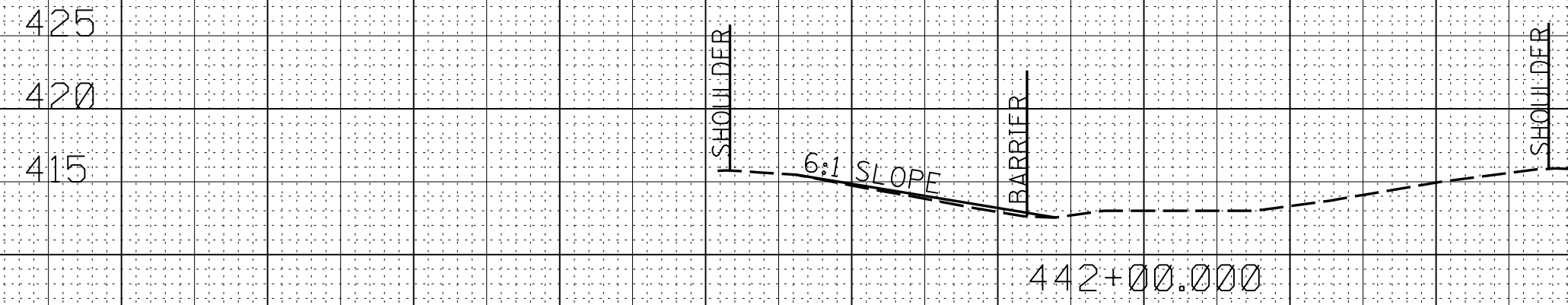
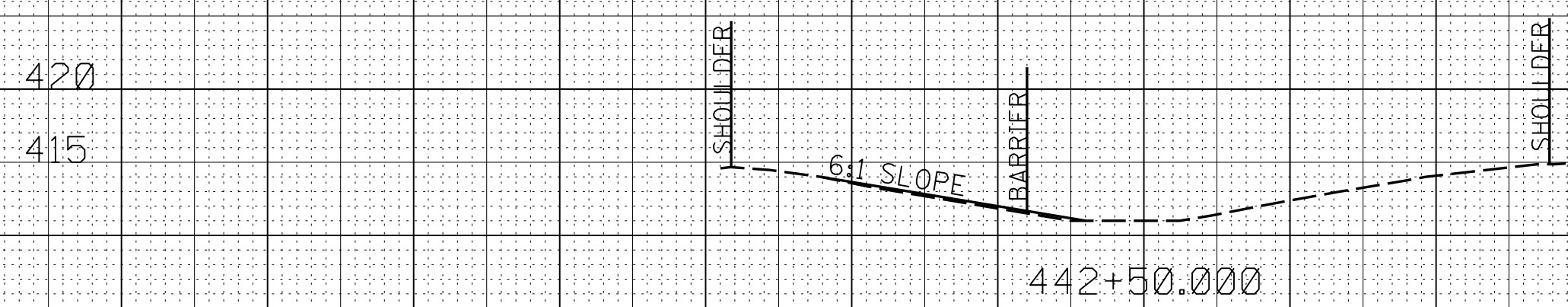
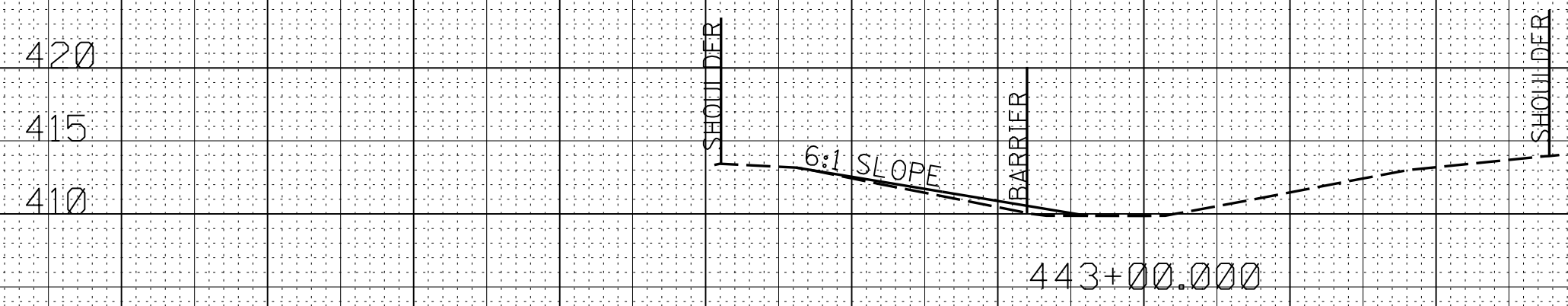
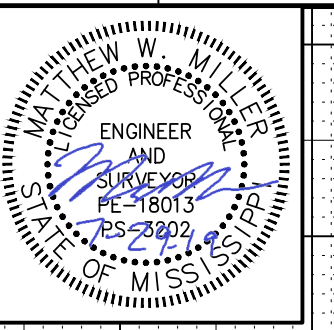

7/30/2019 8:34 AM LAY-COPI.AHI.DGN

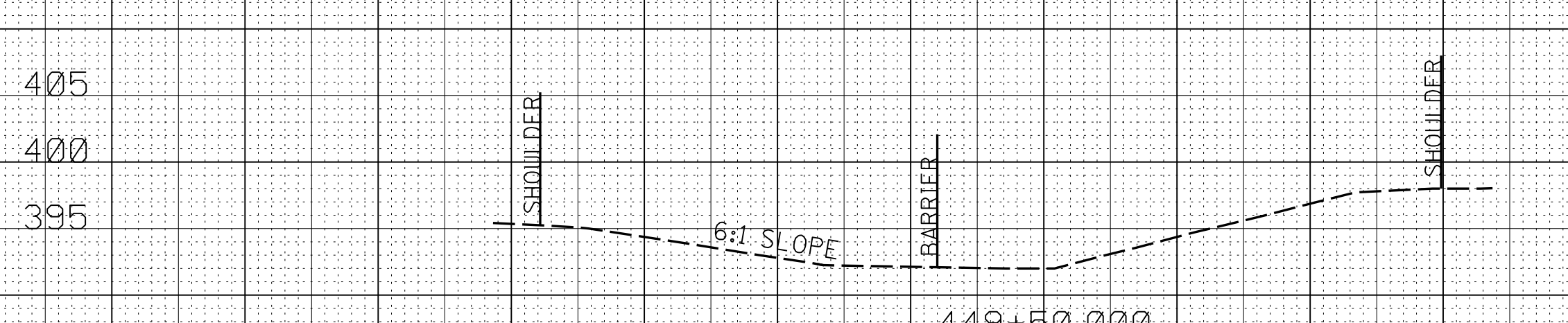
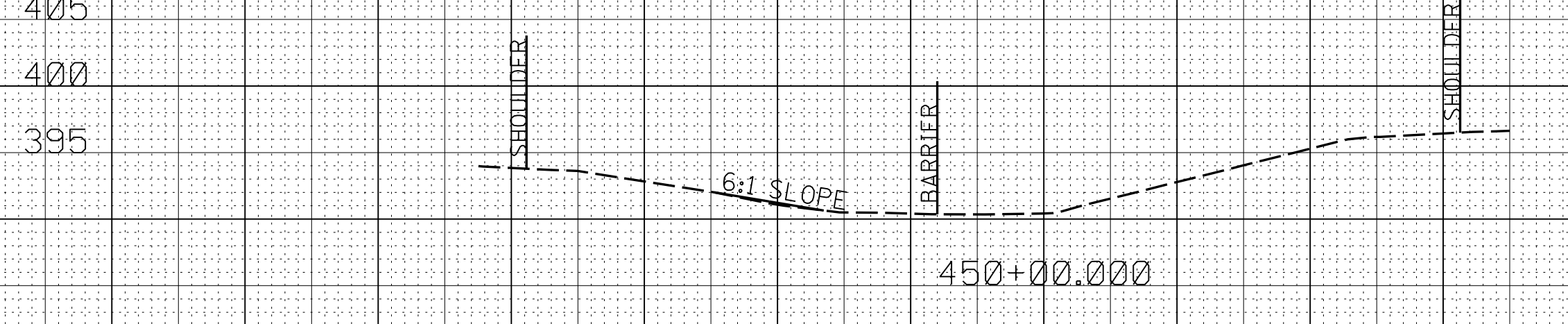
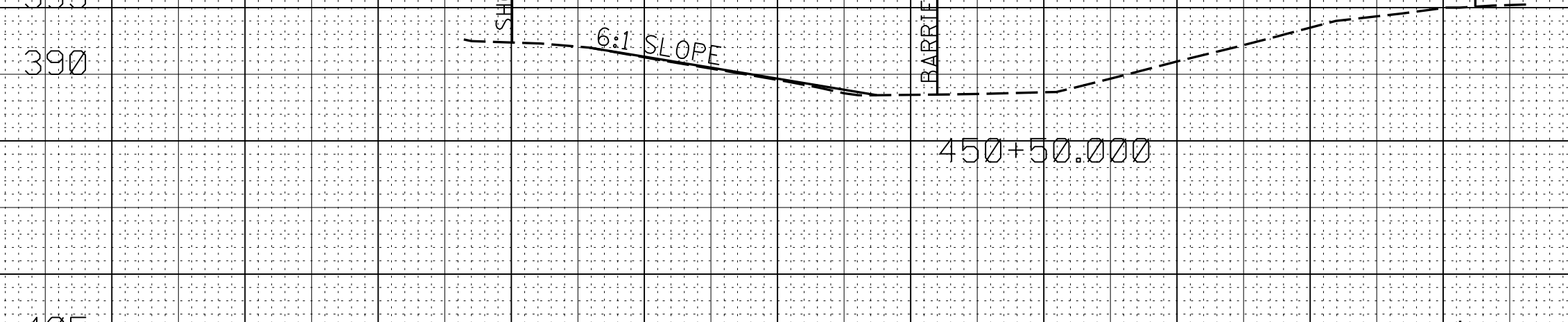
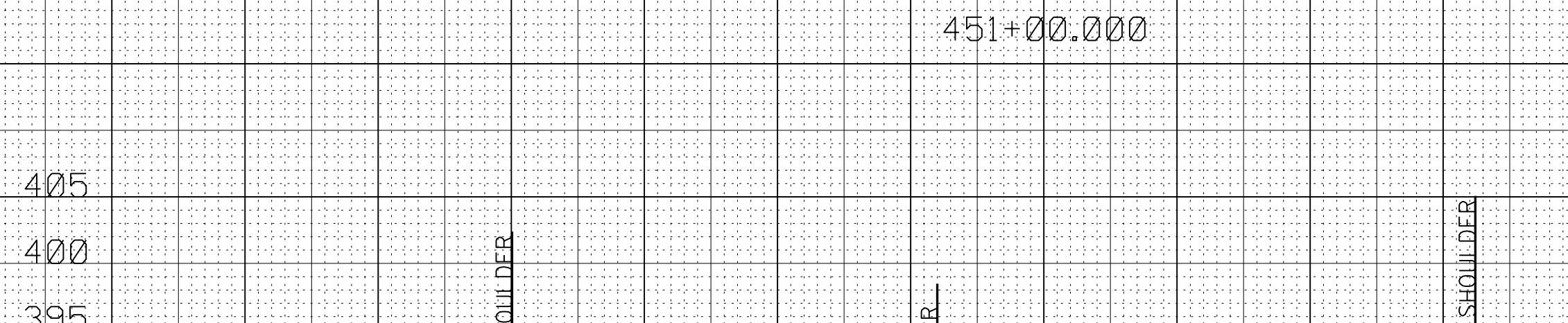
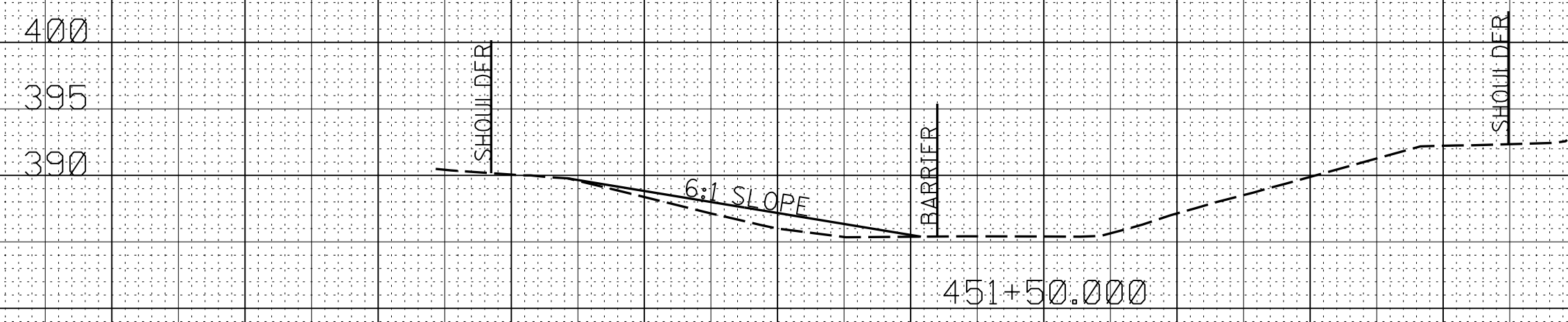
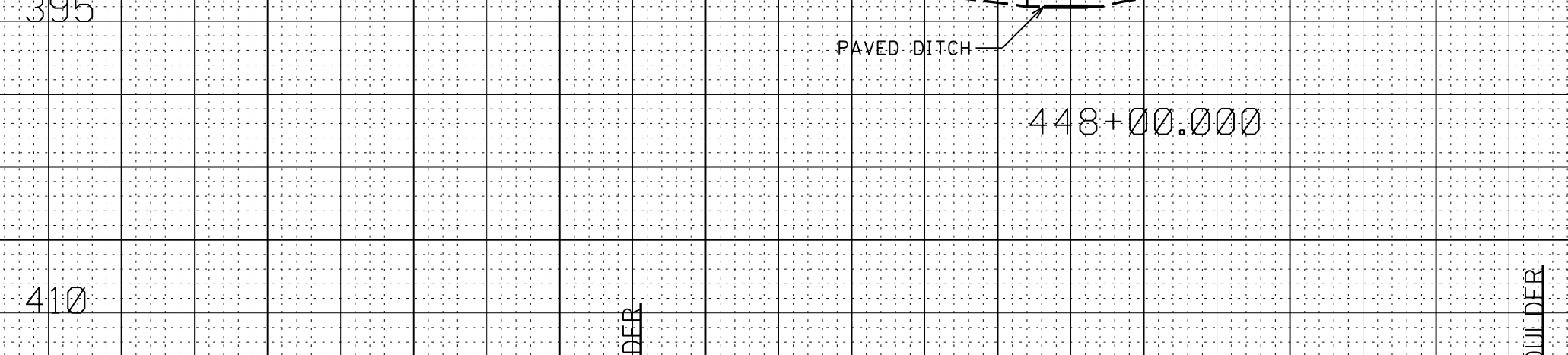
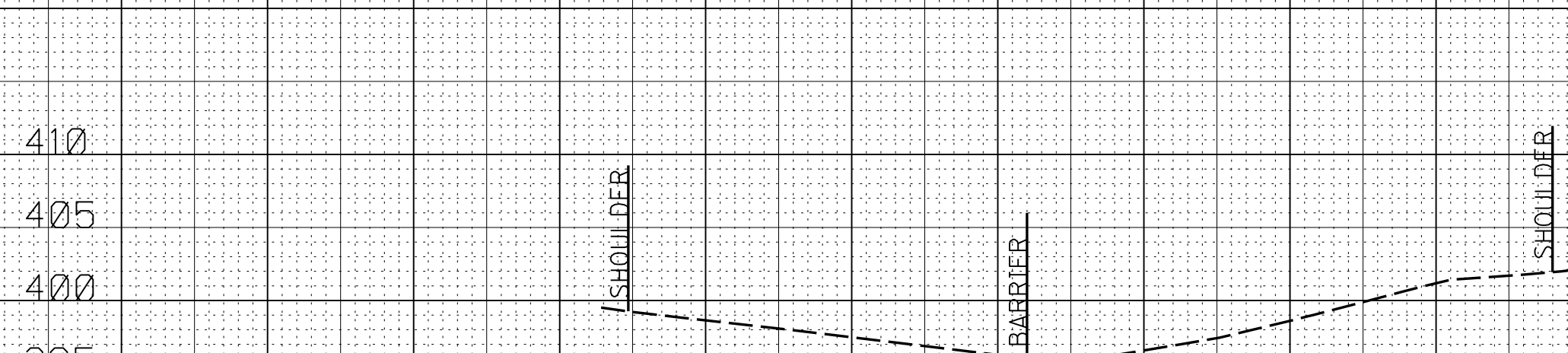
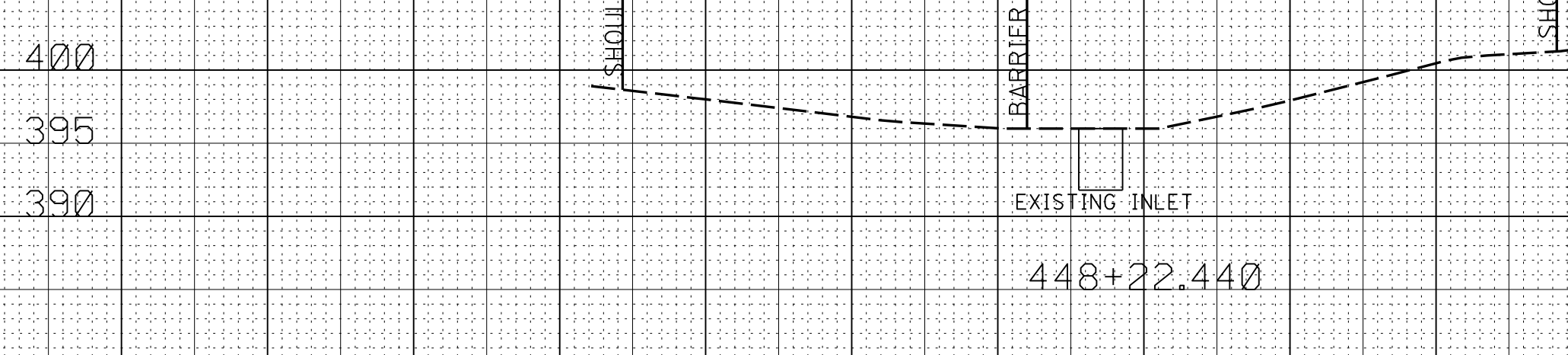
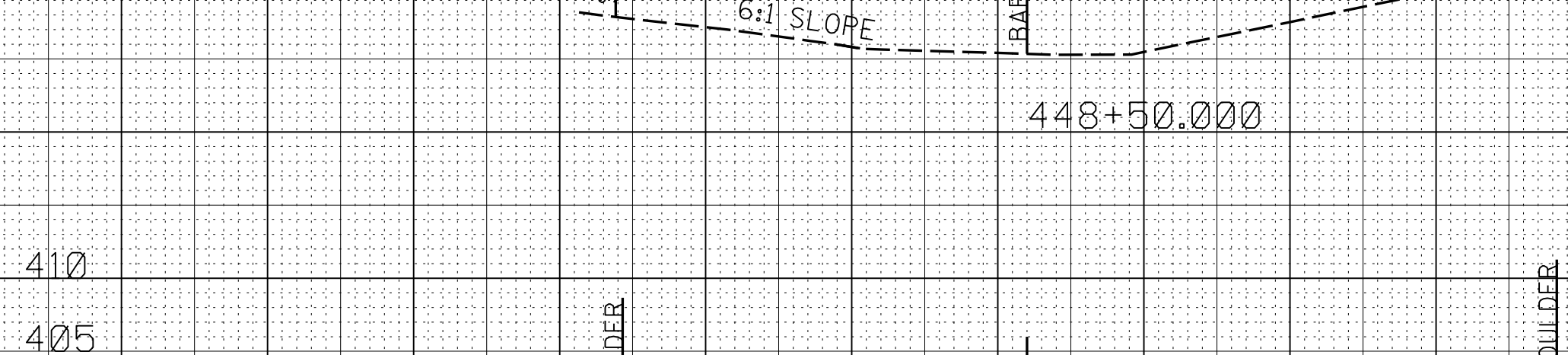
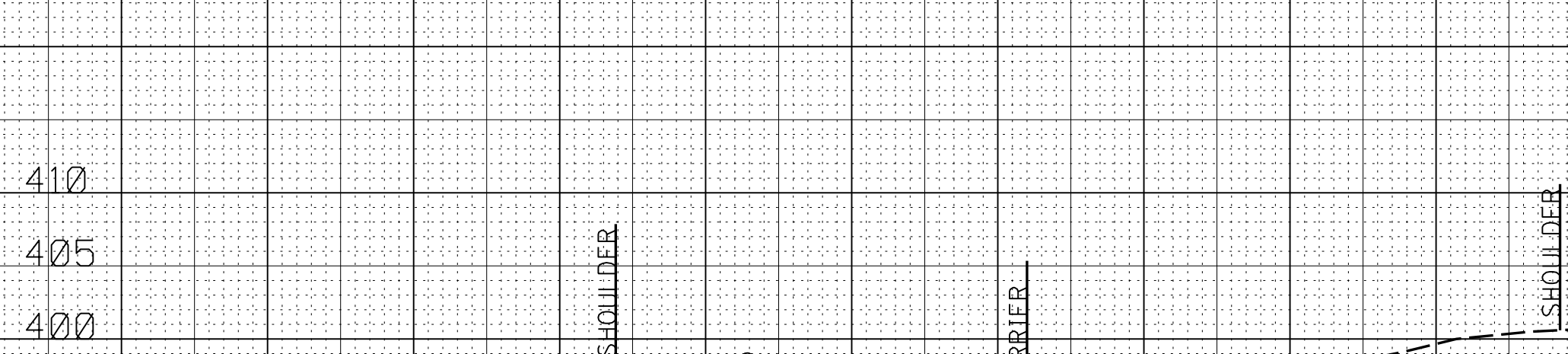
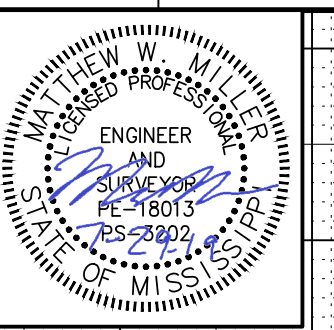

7/30/2019 8:34 AM LAY-COPI.AHI-DGN

80 60 40 20 0 20 40 60 80 80 60 40 20 0 20 40

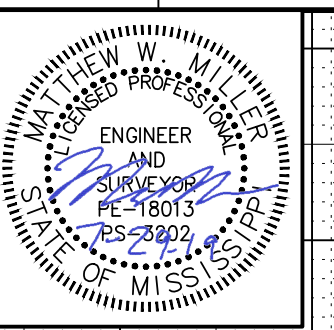

390

385

380

6:1 SLOPE

BARRIER

454+50.000

395

390

385

SHOULDER

6:1 SLOPE

BARRIER

454+00.000

SHOULDER

395

390

385

SHOULDER

6:1 SLOPE

BARRIER

453+50.000

SHOULDER

395

390

385

SHOULDER

6:1 SLOPE

BARRIER

453+00.000

SHOULDER

400

395

390

385

SHOULDER

6:1 SLOPE

BARRIER

452+50.000

SHOULDER

400

395

390

385

SHOULDER

6:1 SLOPE

BARRIER

452+00.000

SHOULDER

7/30/2019 8:34 AM LAY-COPI.AHI.DGN

80 60 40 20 0 20 40 60 80 80 60 40 20 0 20 40

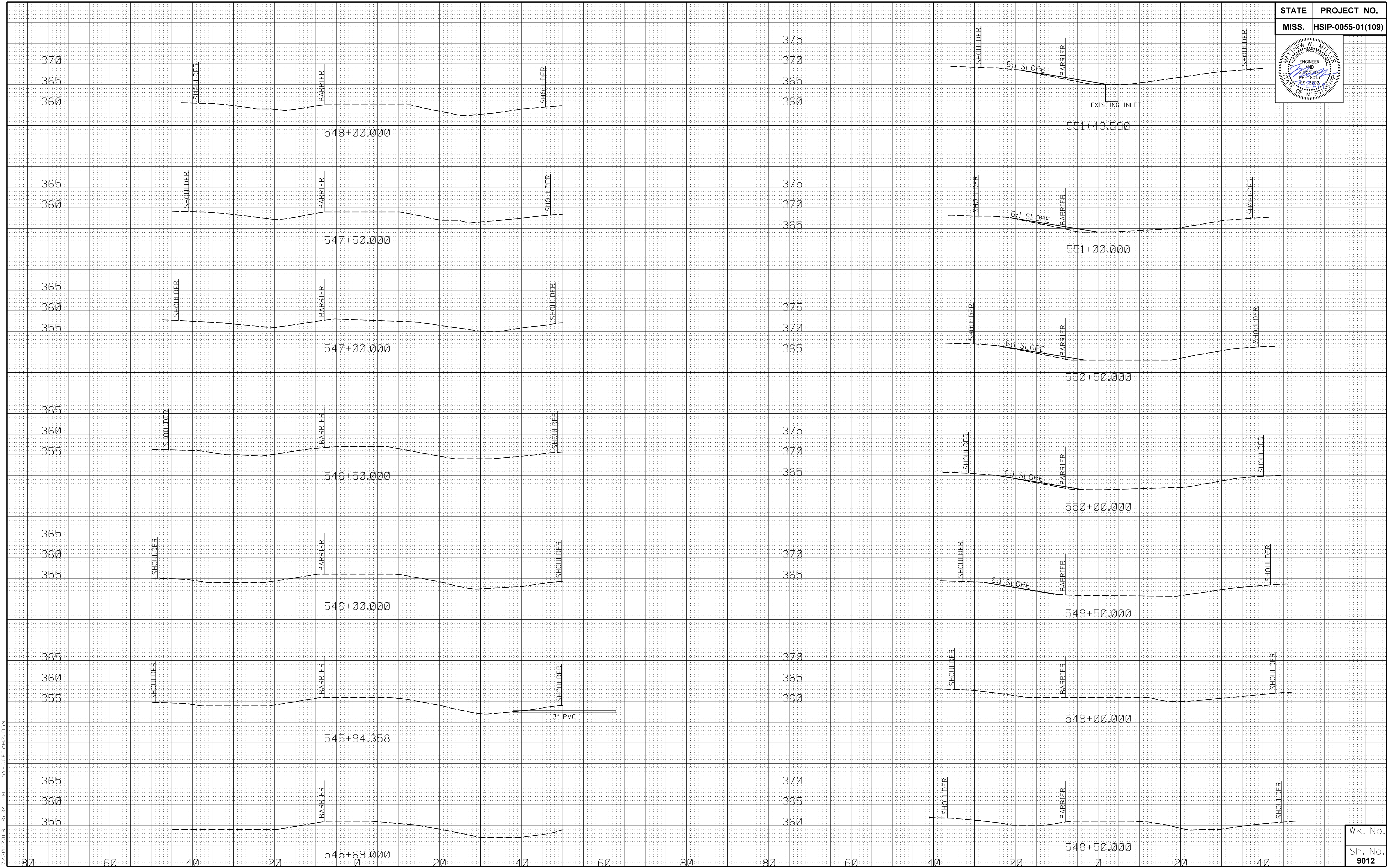
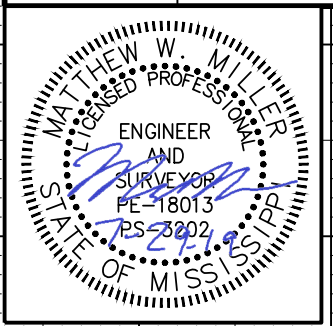

7/26/2019 8:34 AM LAY-COPI-AH2.DGN

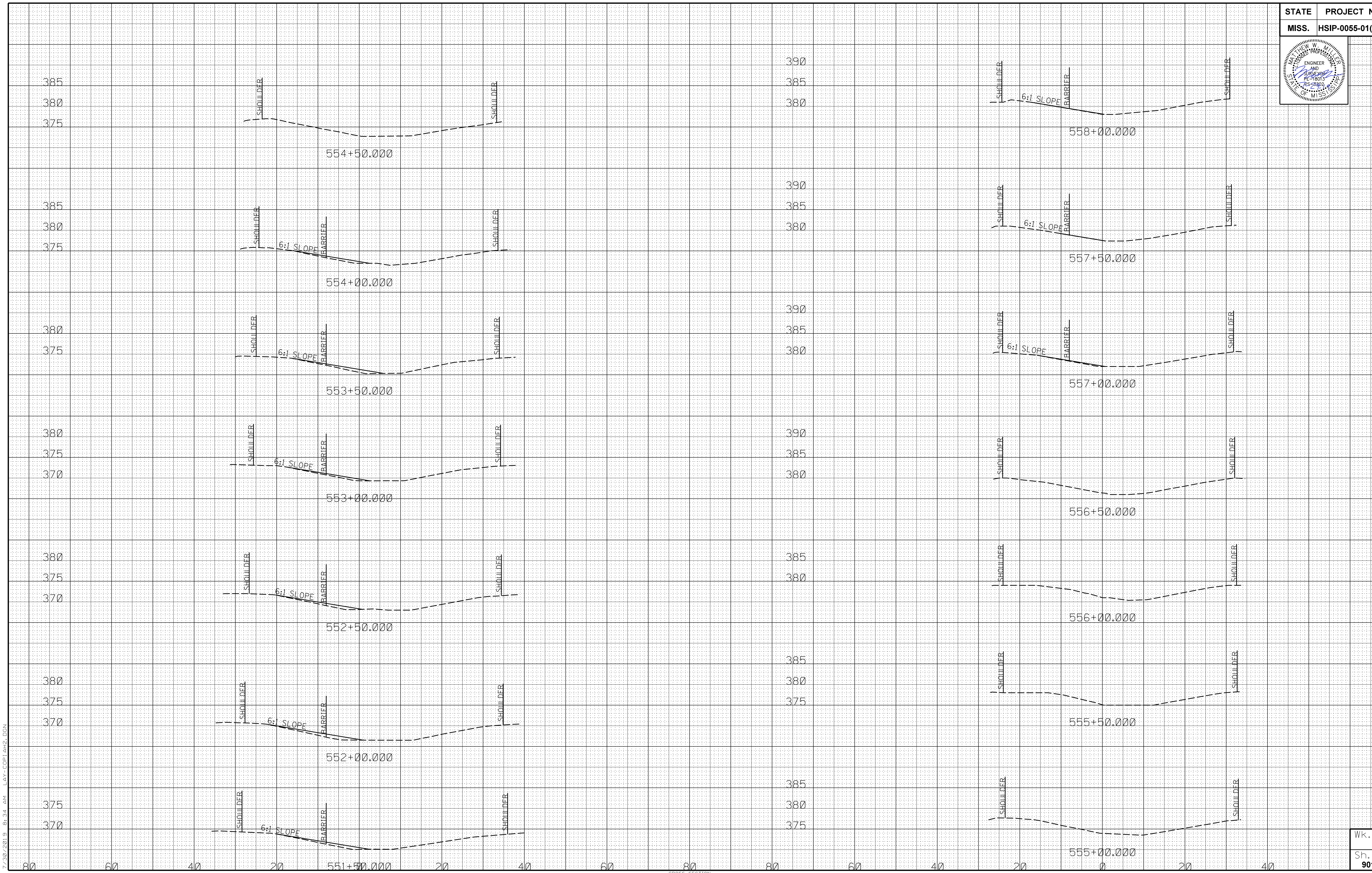
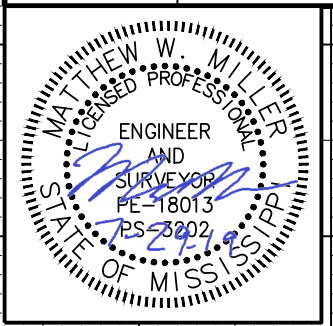

7/26/2019 8:34 AM LAY-COPI.AH2.DGN

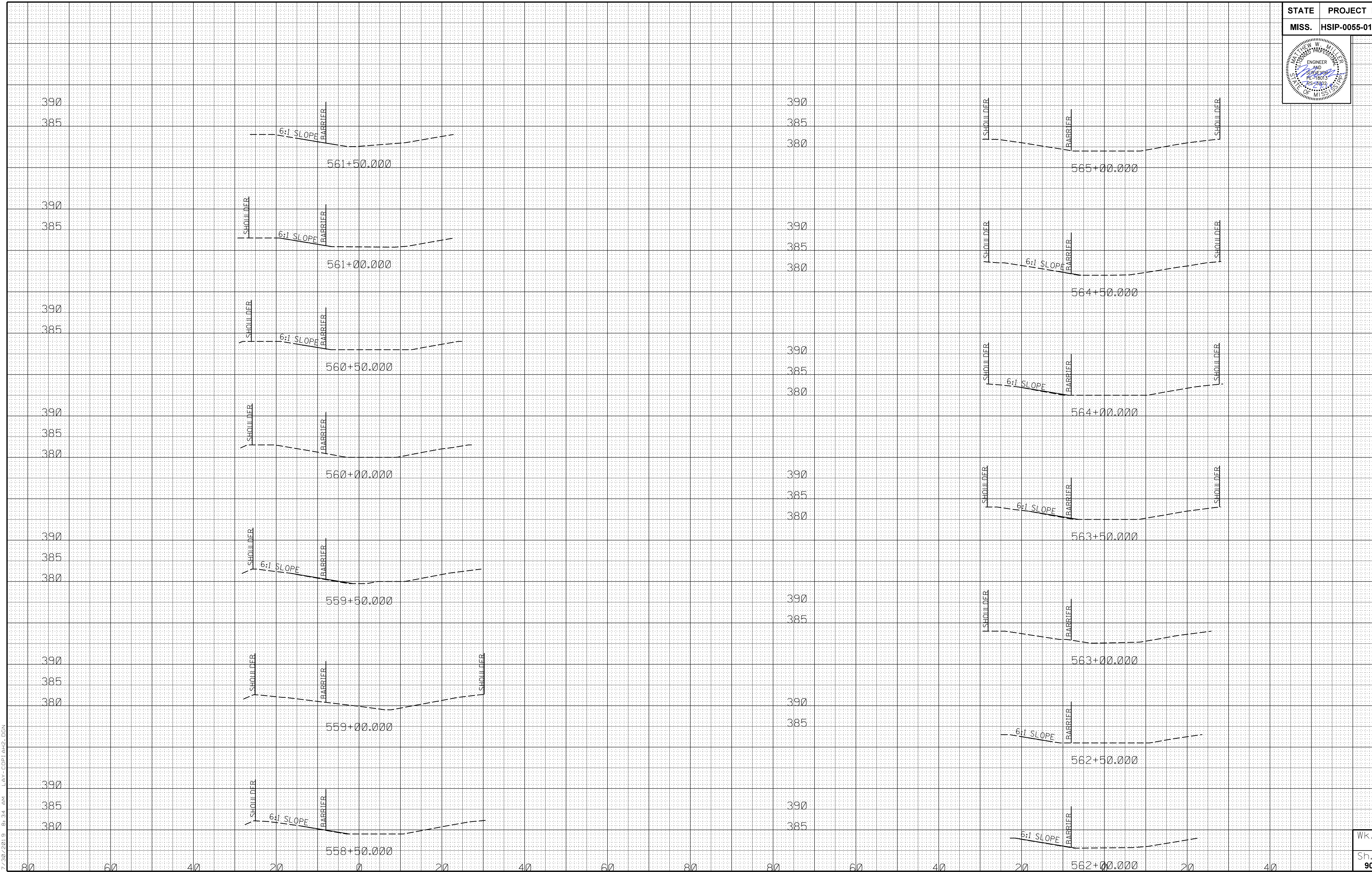
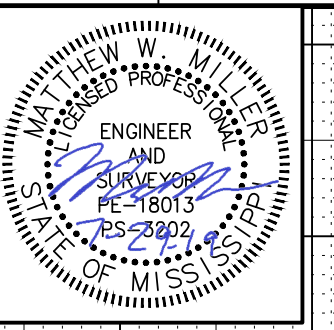

7/30/2019 8:34 AM LAY-COPI-AH2.DGN

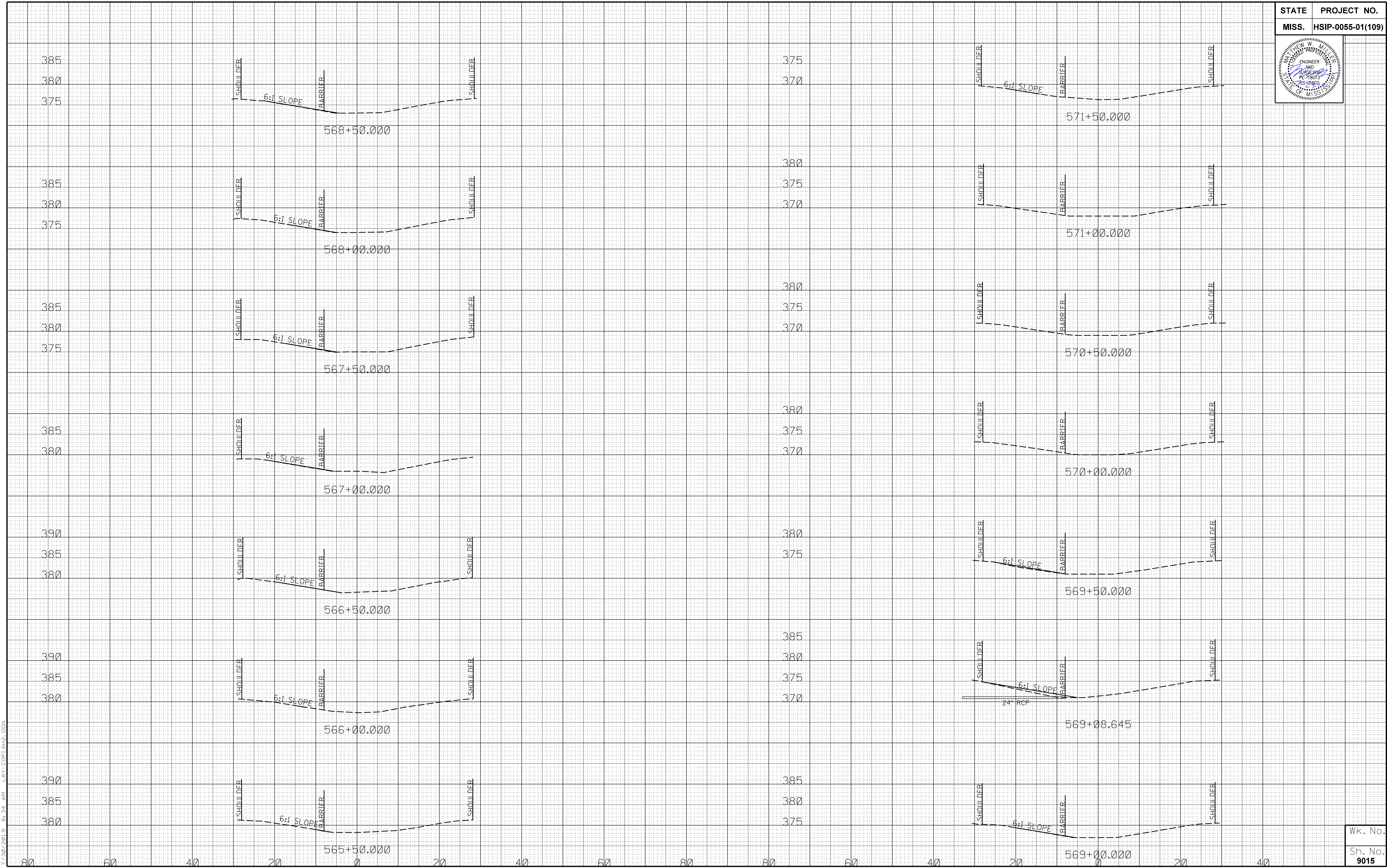
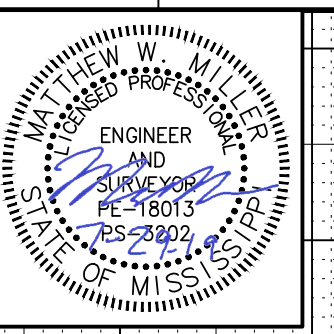

7/30/2019 8:34 AM LAY-COPI-AH2.DGN

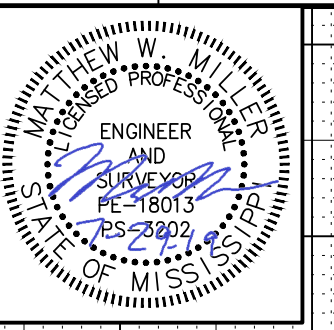

370
365
360

370
365
360

370
365

375
370
365

375
370
365

375
370
365

375
370
365

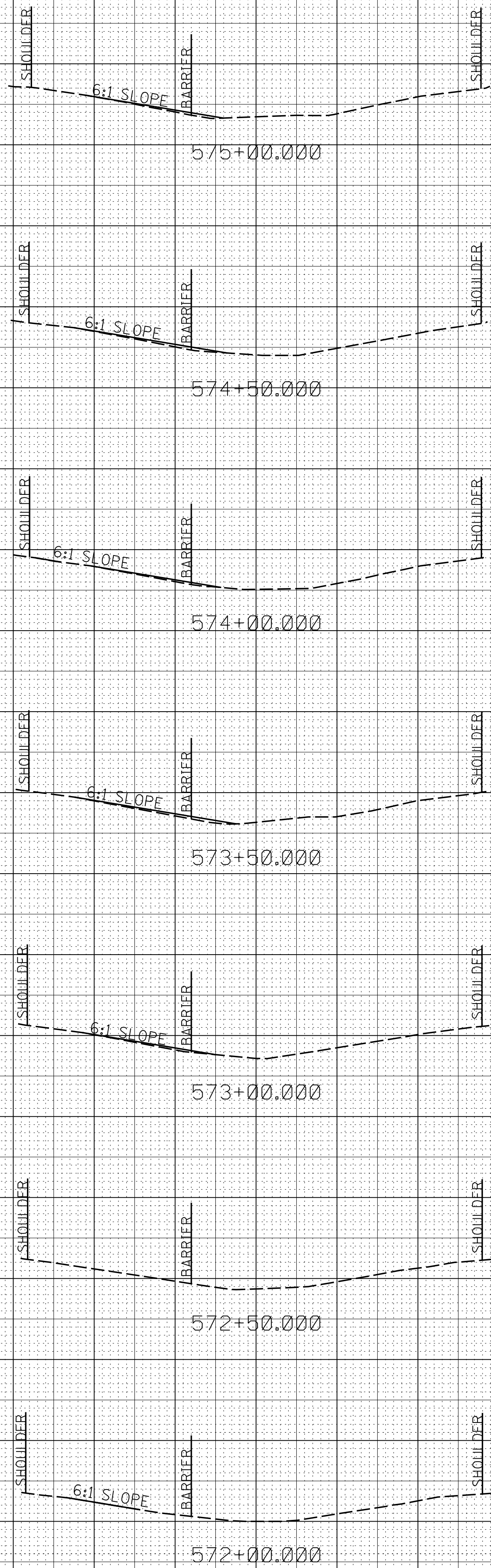

365
360
355

365
360
355

365
360
355

365
360
355

365
360

370
365
360
355

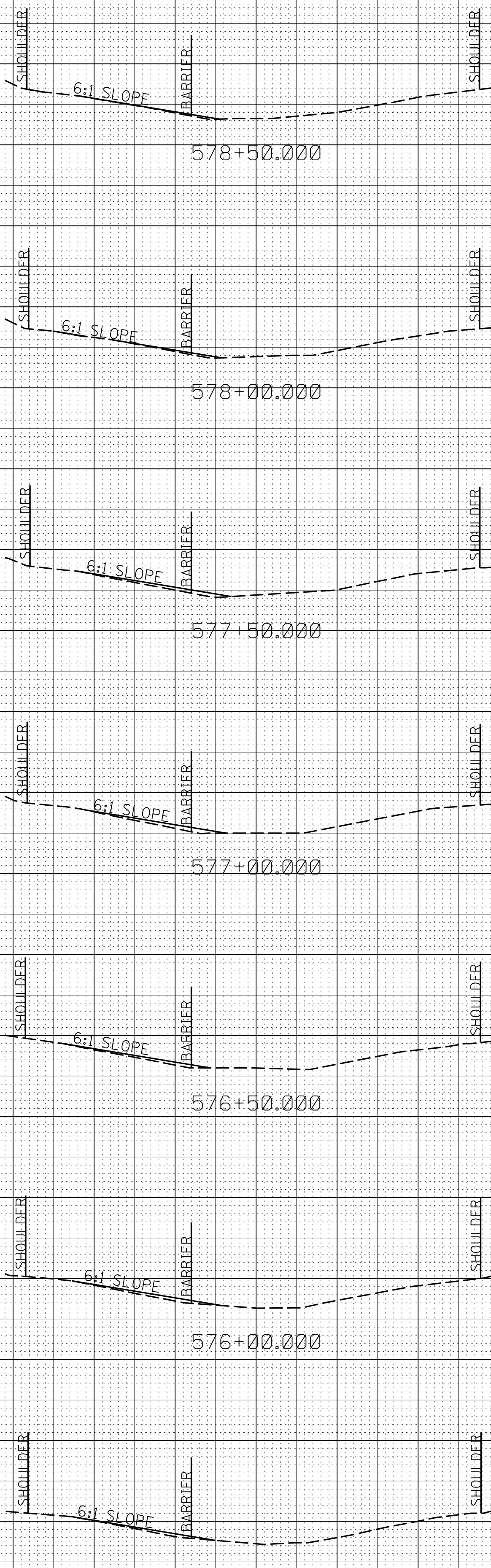

80 60 40 20 0 20 40 60 80 80 60 40 20 0 20 40

7/30/2019 8:34 AM LAY-COPI-AH2.DGN

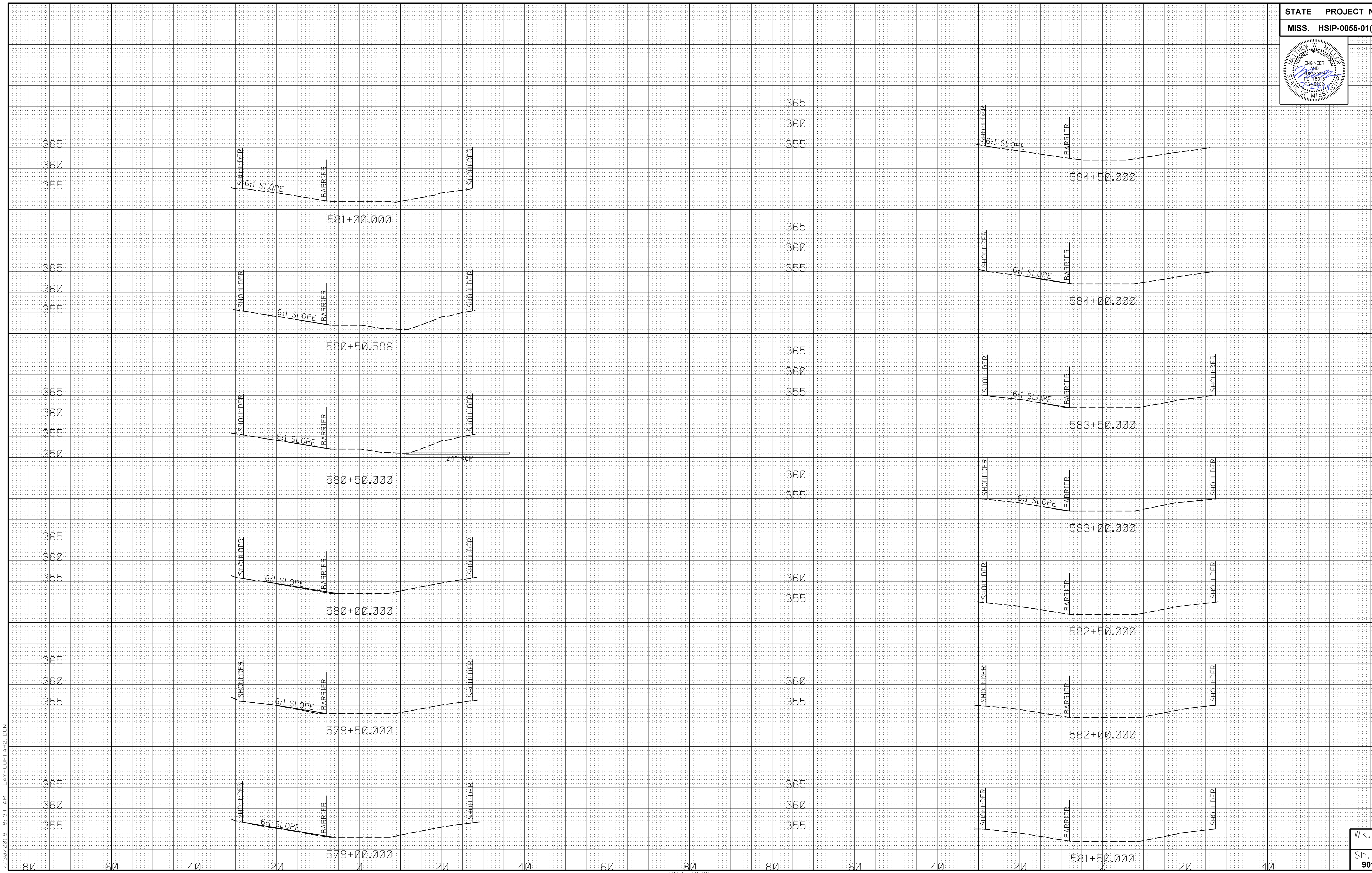
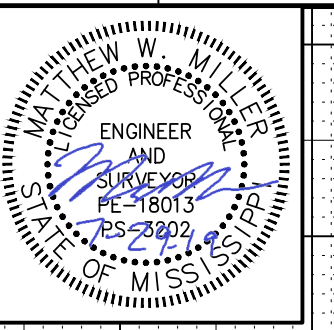

7/30/2019 8:34 AM LAY-COPI-AH2.DGN

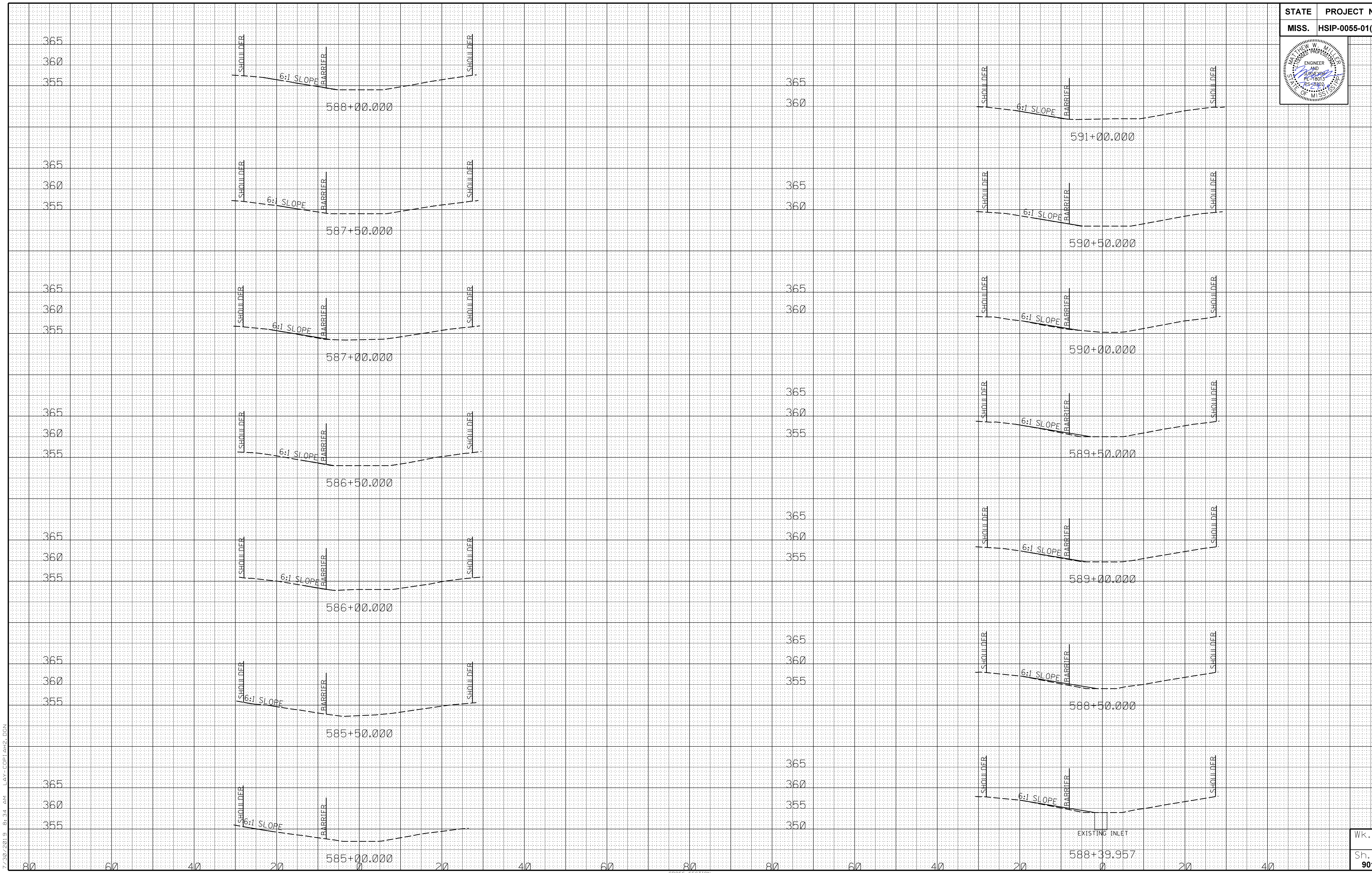
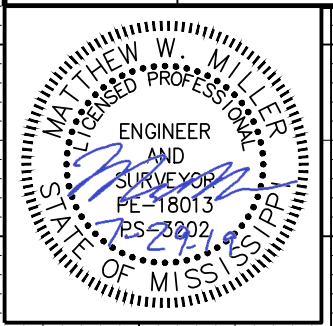

7/30/2019 8:34 AM LAY-COPI-AH2.DGN

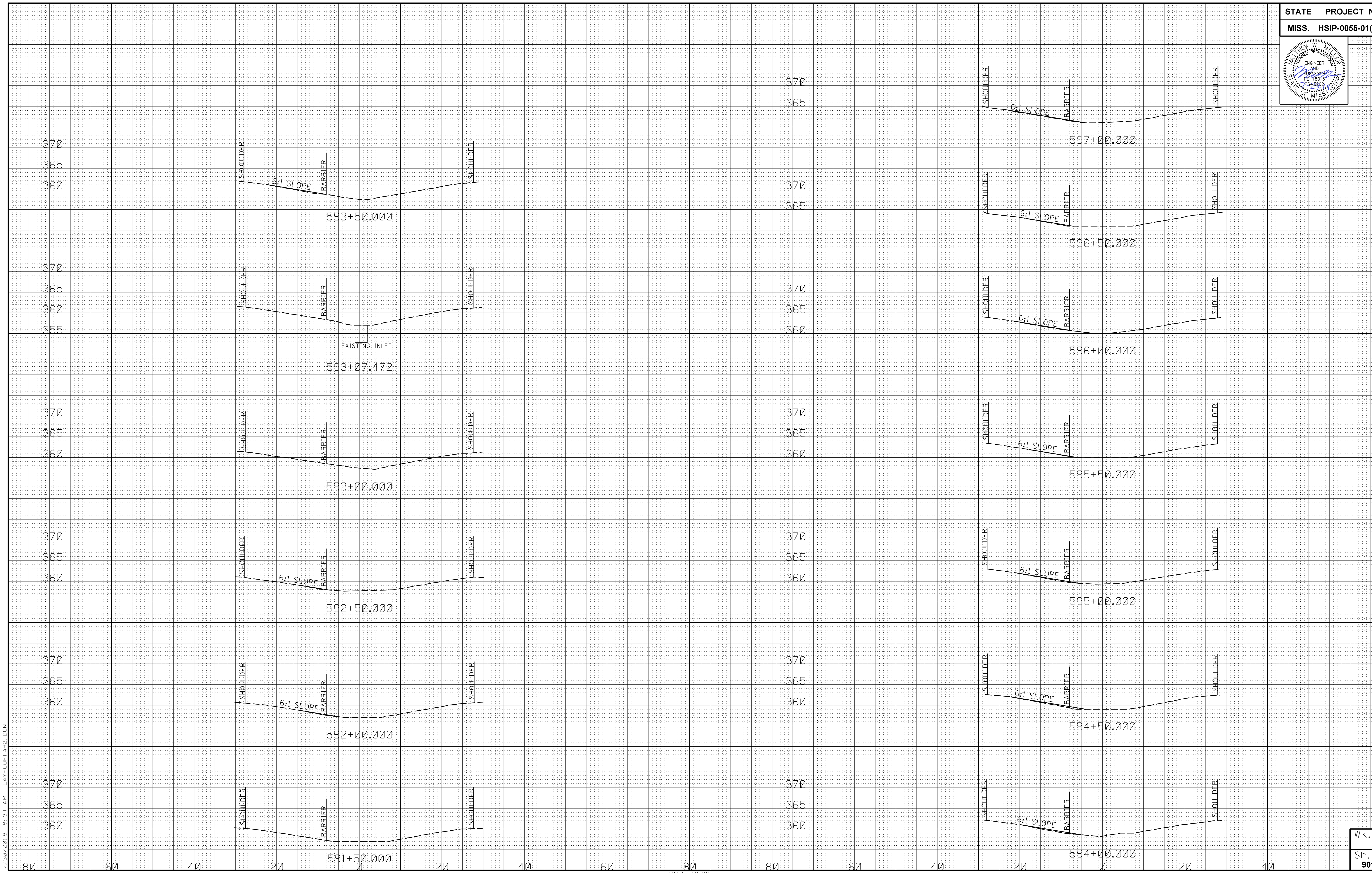
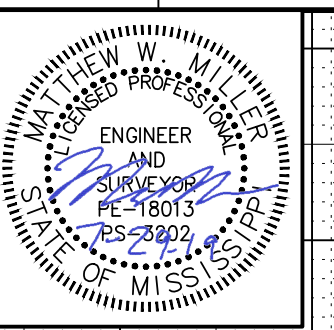

7/30/2019 8:34 AM LAY-COPI-AH2.DGN

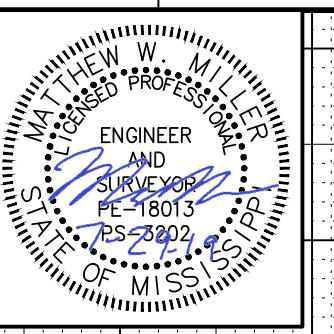

375
370
365
375
370
365
375
370
365
375
370
365
375
370
365
375
370
365

385
380
375
380
375
380
375
370
380
375
370
375
370
370
365

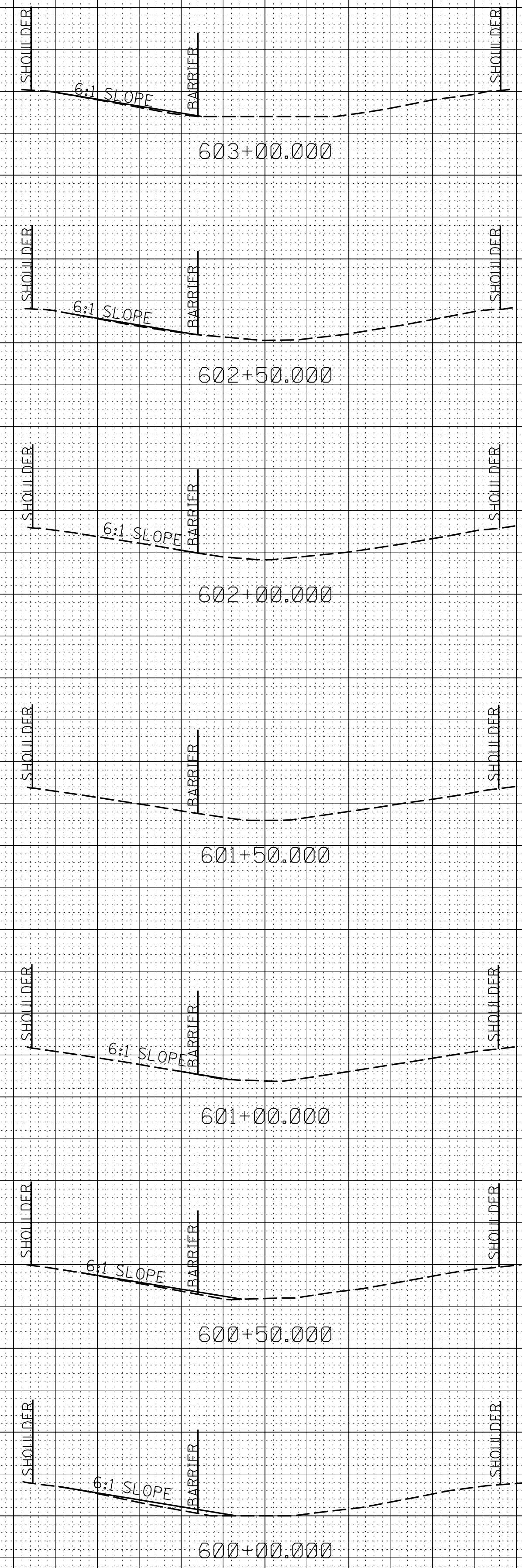
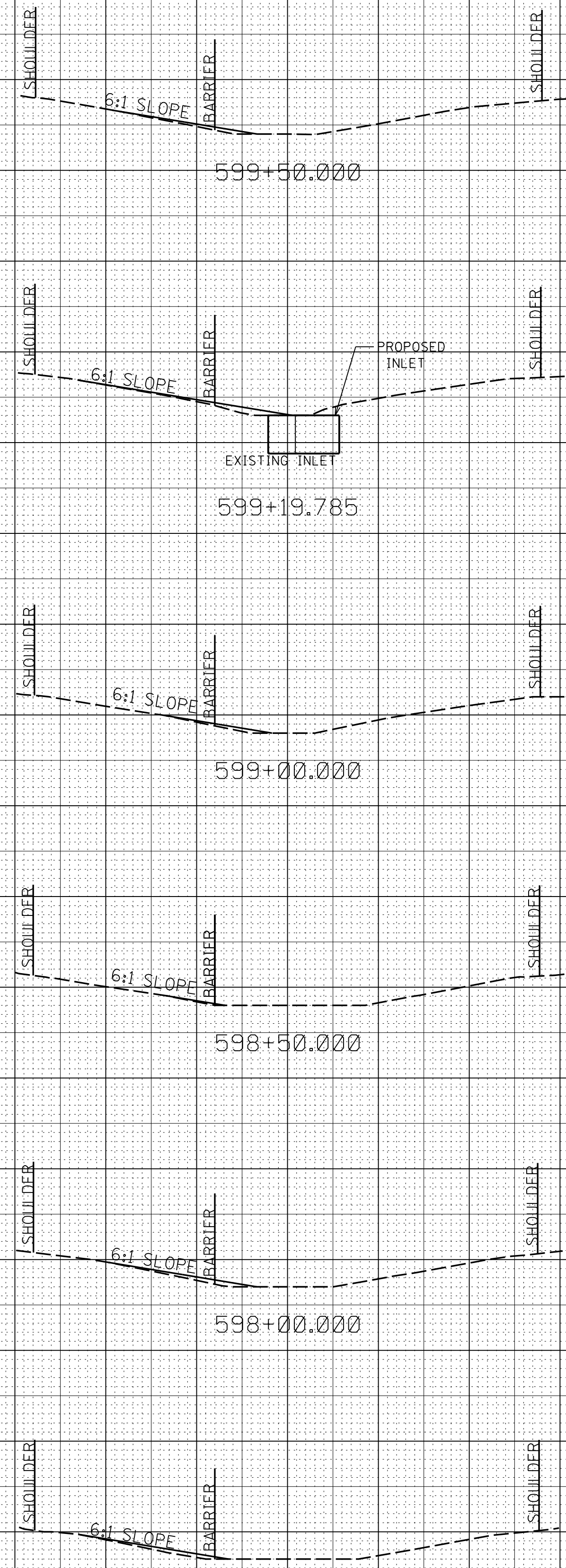

7/30/2019 8:34 AM LAY-COPI-AH2.DGN

80 60 40 20 0 20 40 60 80 80 60 40 20 0 20 40

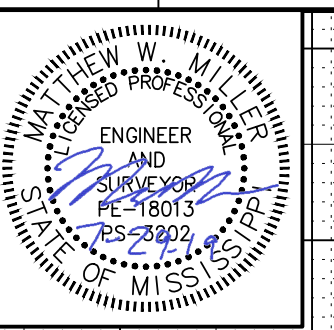

7/30/2019 8:34 AM LAY-COPI-AH2.DGN

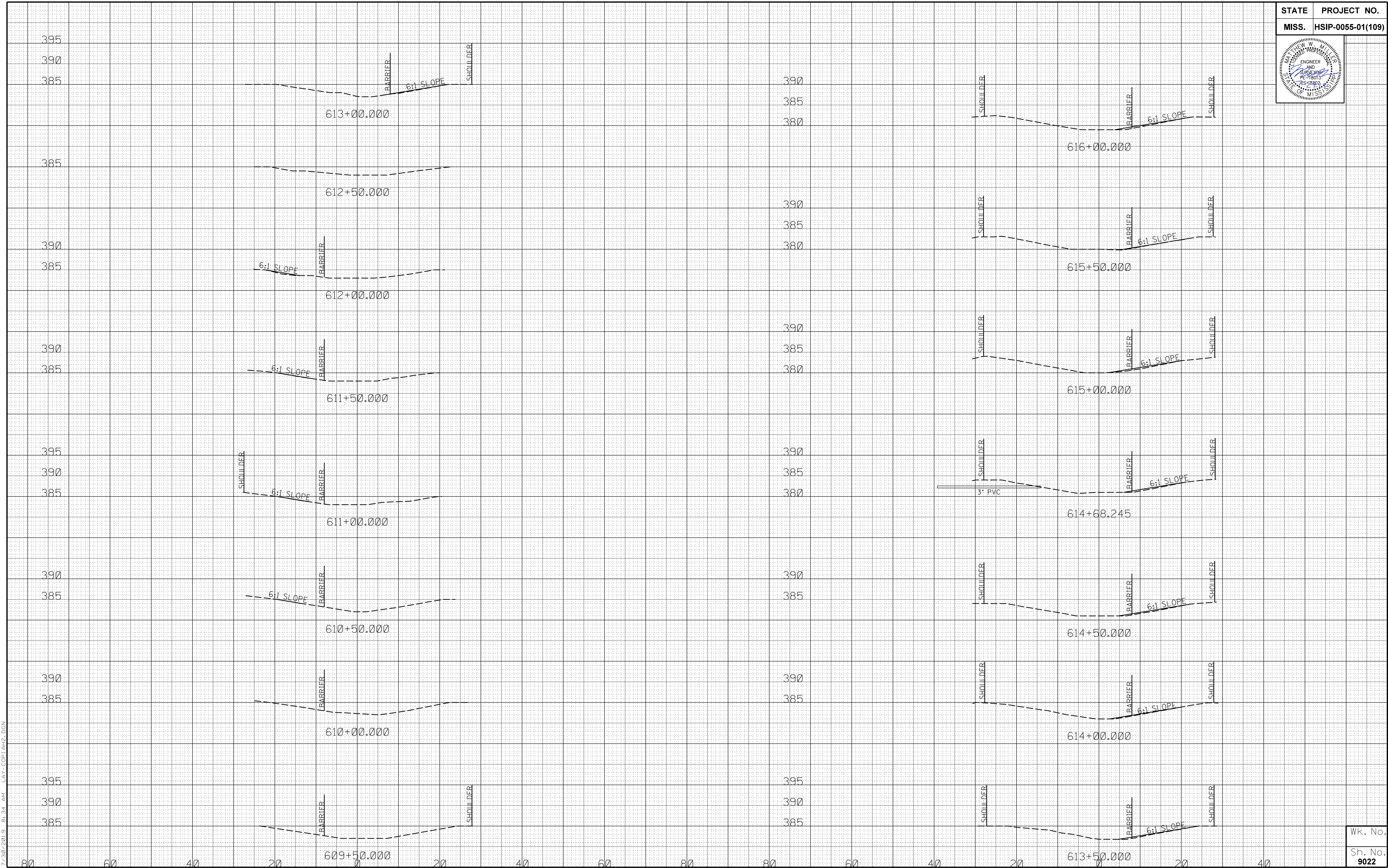
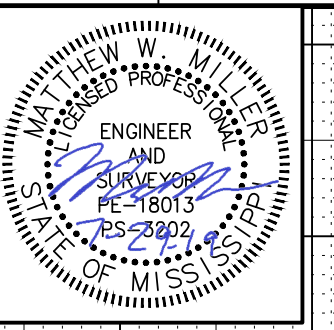

7/30/2019 8:34 AM LAY-COPI-AH2.DGN

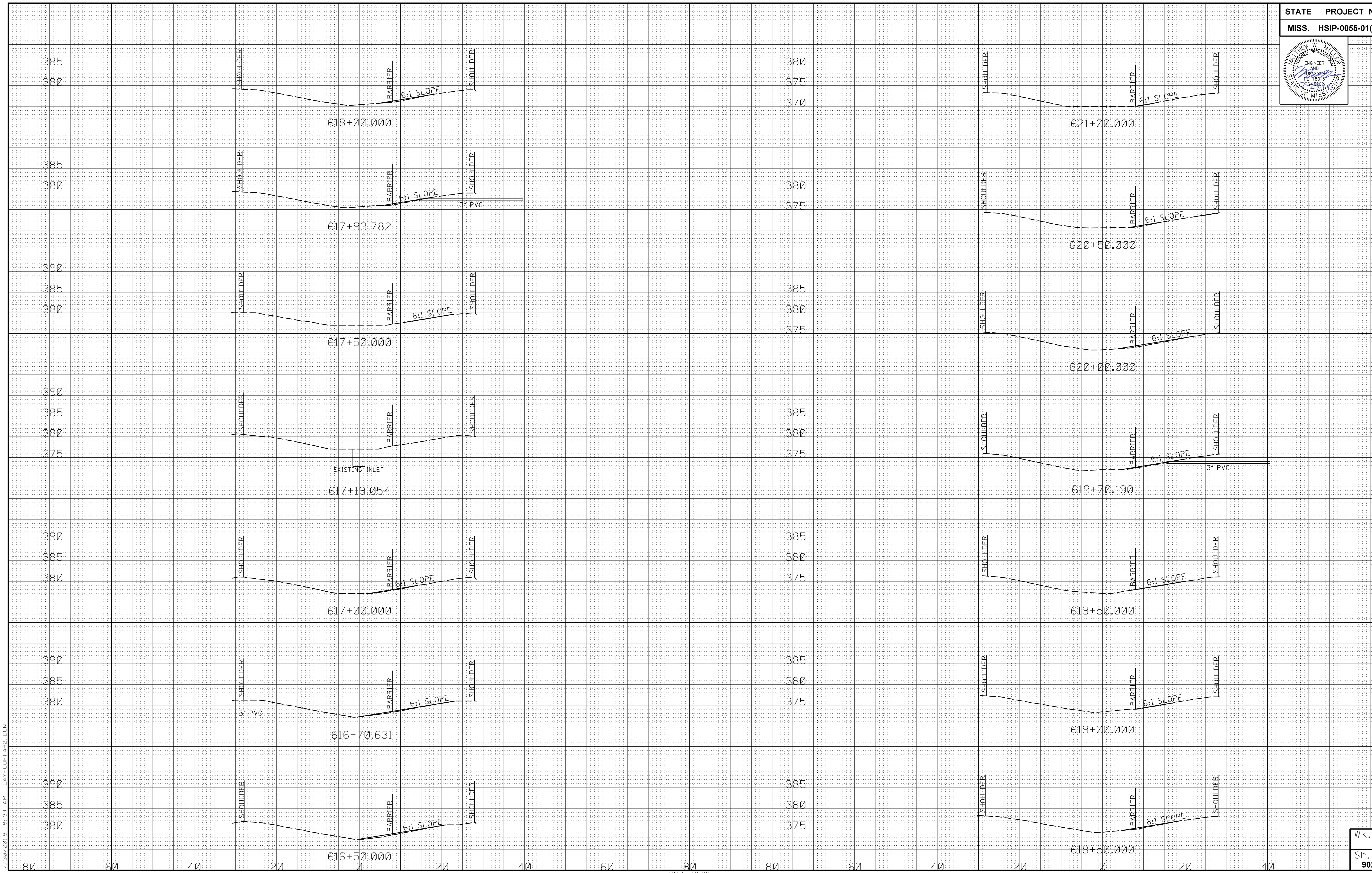
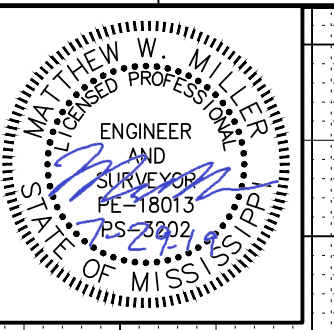

7/30/2019 8:34 AM LAY-COPI-AH2.DGN

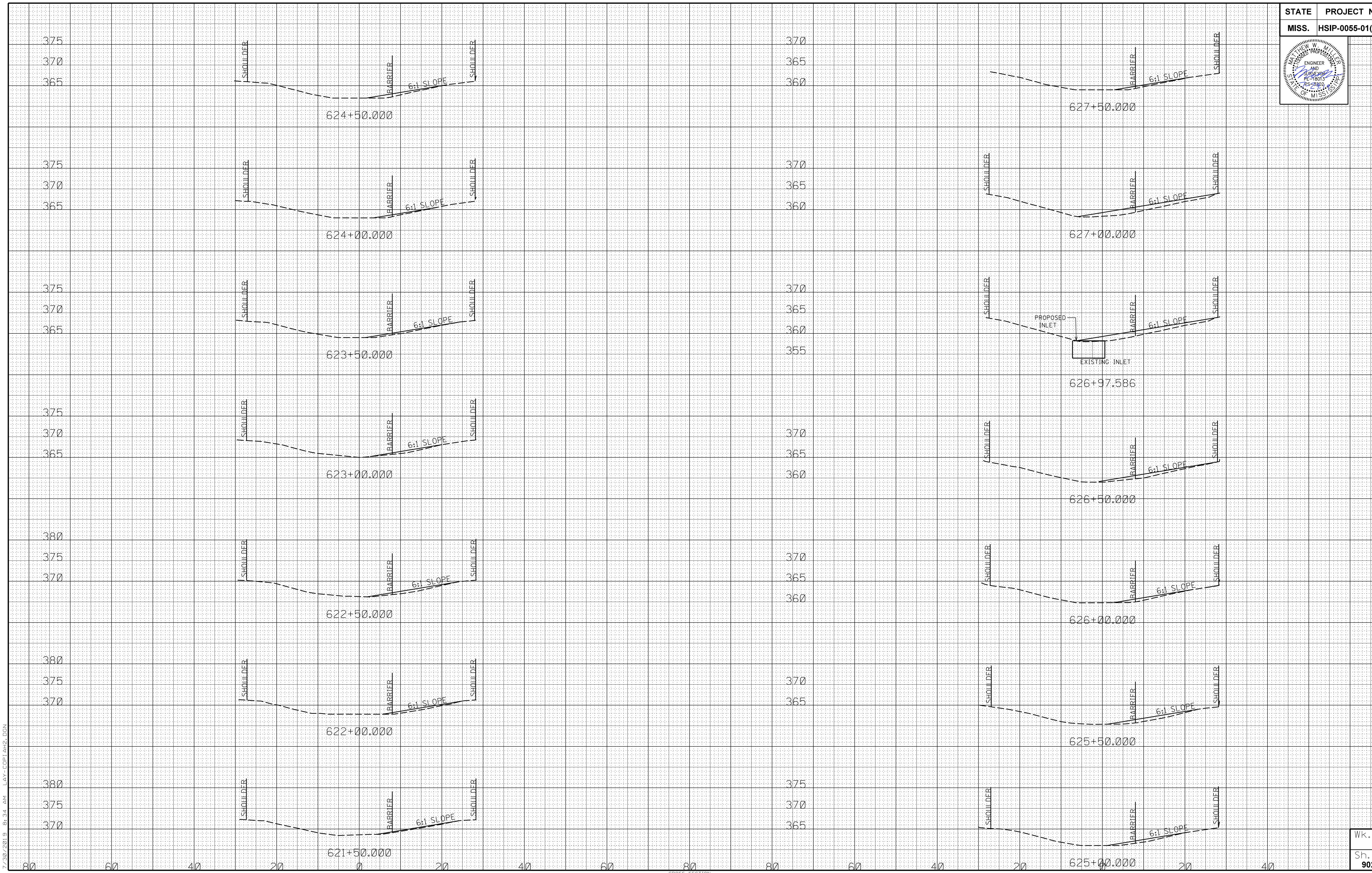
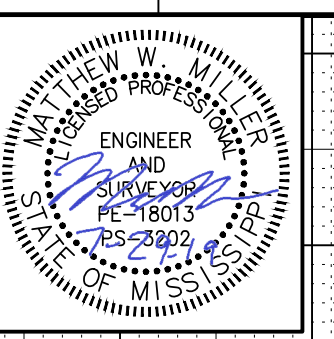

7/30/2019 8:34 AM LAY-COPI-AH2.DGN

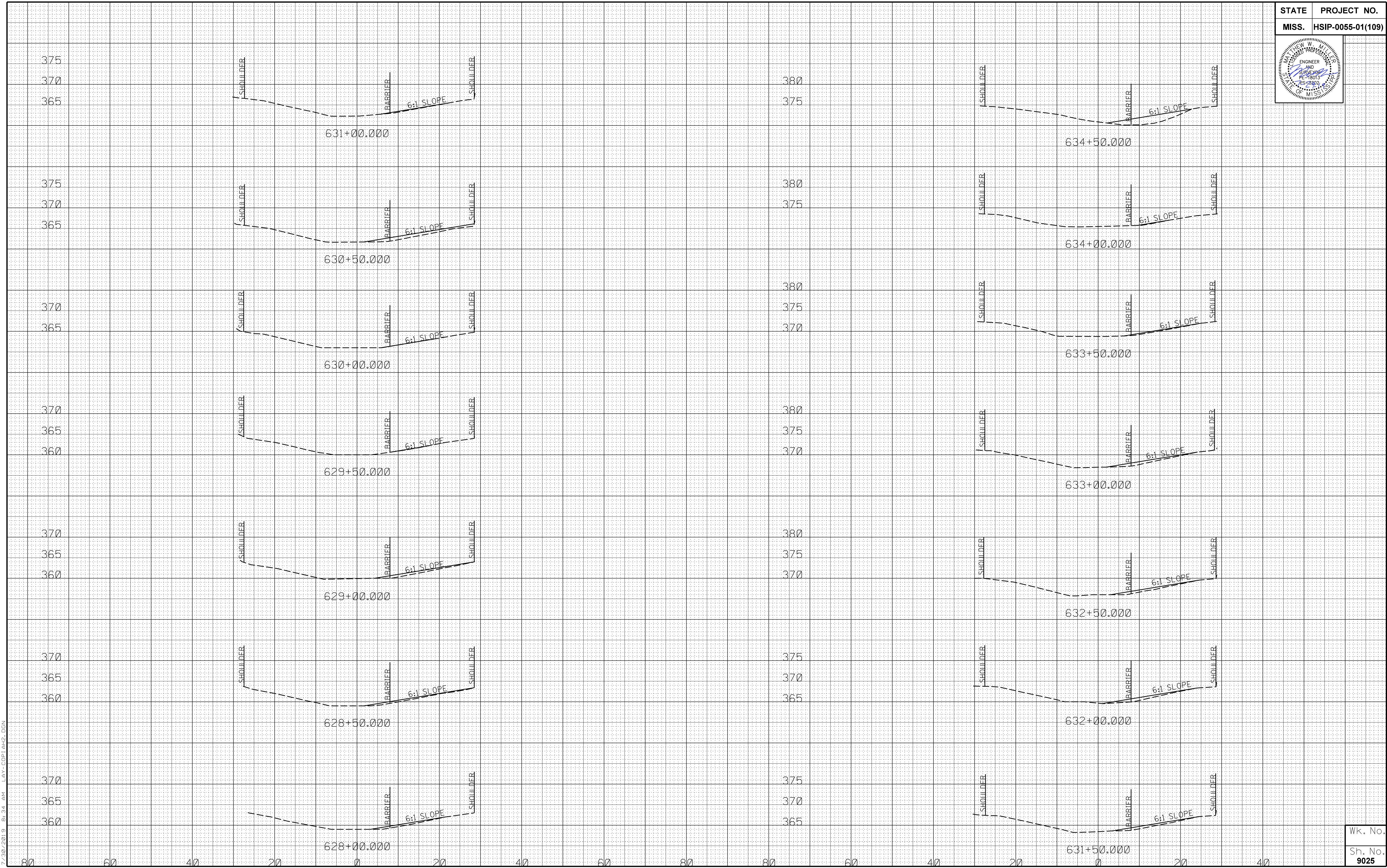
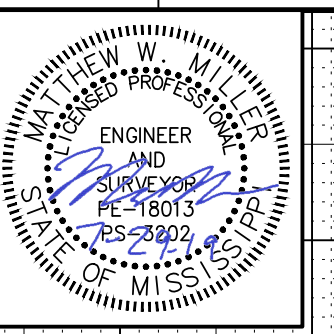

7/30/2019 8:34 AM LAY-COPI-AH2.DGN

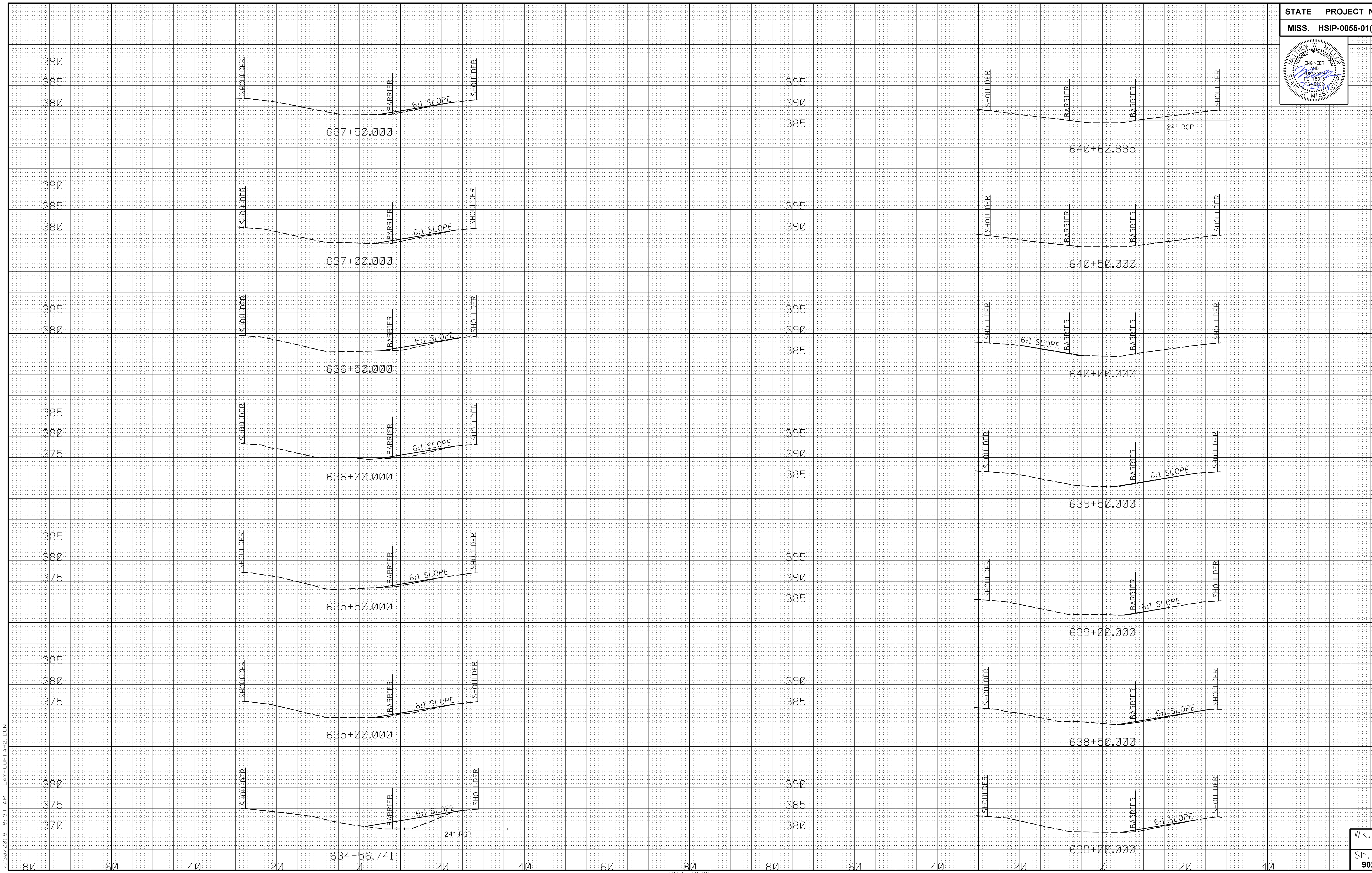
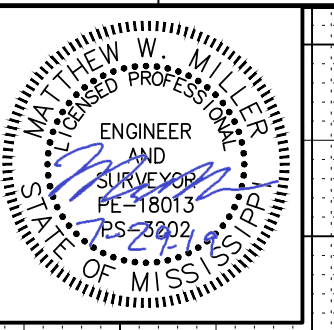

7/30/2019 8:34 AM LAY-COPI-AH2.DGN

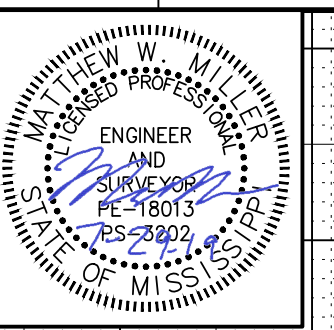

7/30/2019 8:34 AM LAY-COPI-AH2.DGN

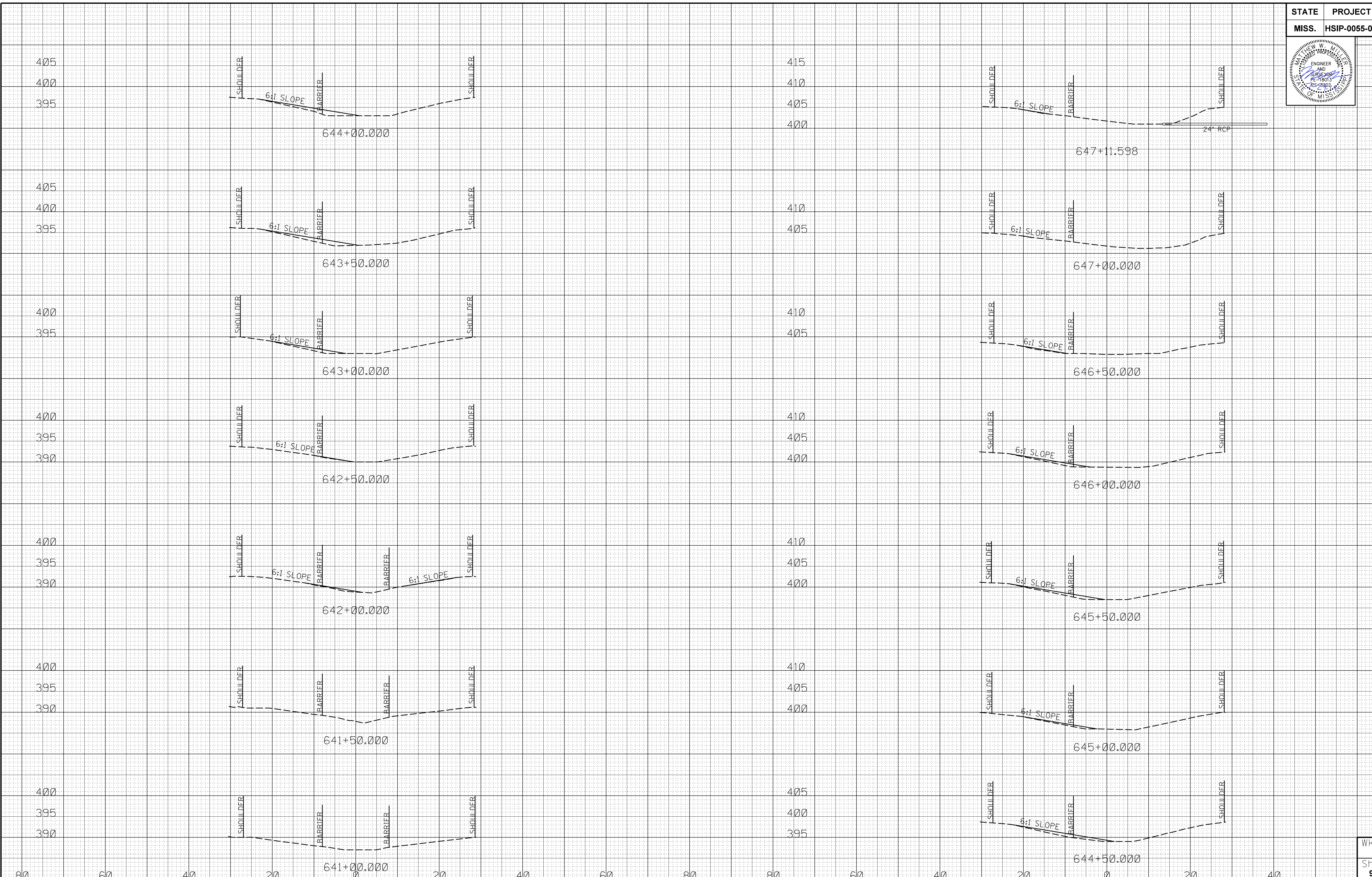

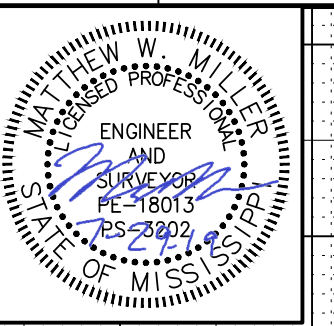

7/30/2019 8:34 AM LAY-COPI-AH2.DGN

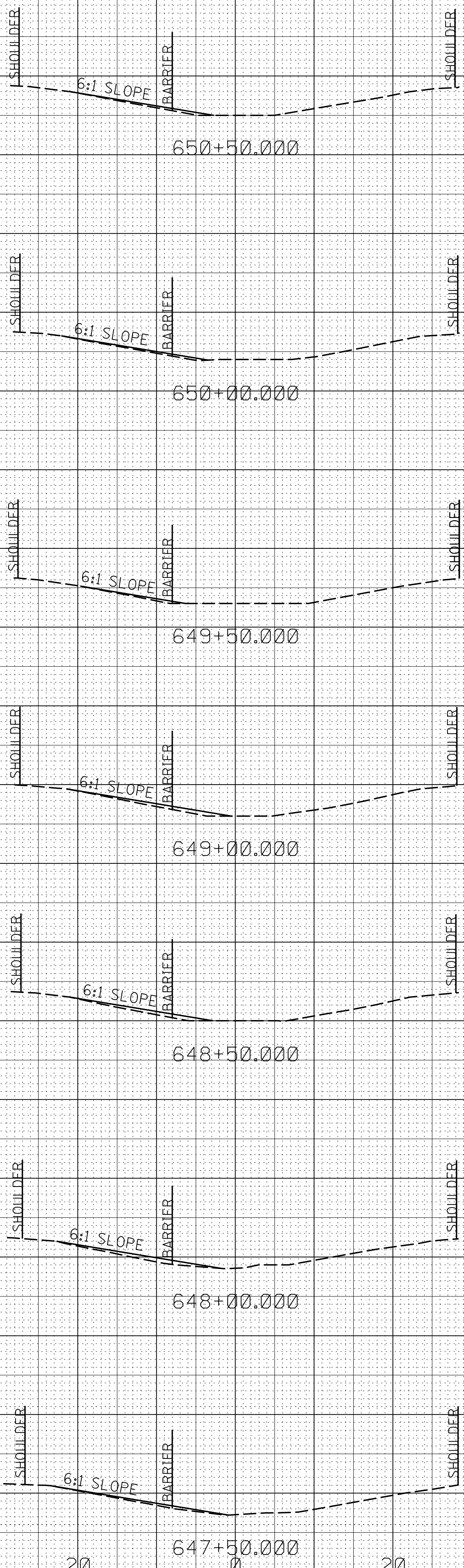

430
425
420
430
425
420
430
425
420
425
420
415
425
420
415
425
420
415
420
415

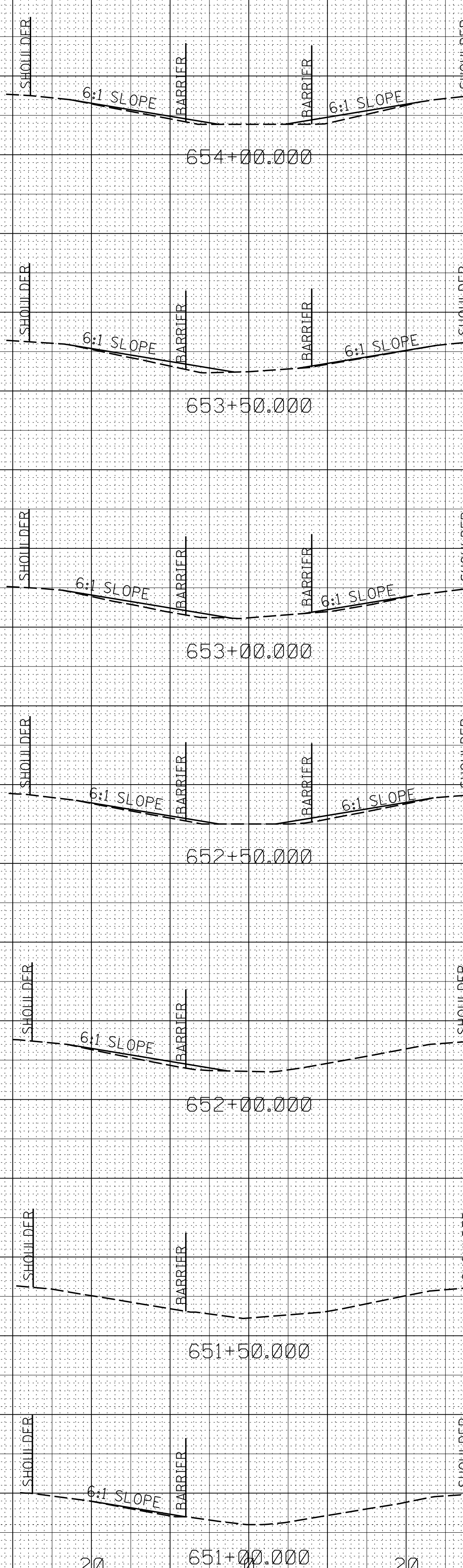

80 60 40 20 0 20 40 60 80 80 60 40 20 0 20 40 60 80 20 40 60 80 20 40

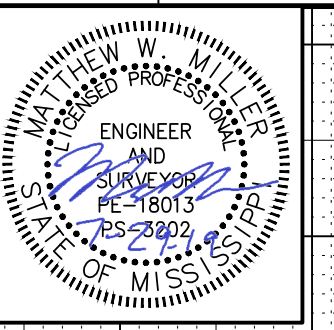

440
435
430

440
435
430

435
430
425

435
430
425

435
430
425

435
430
425

430
425
420

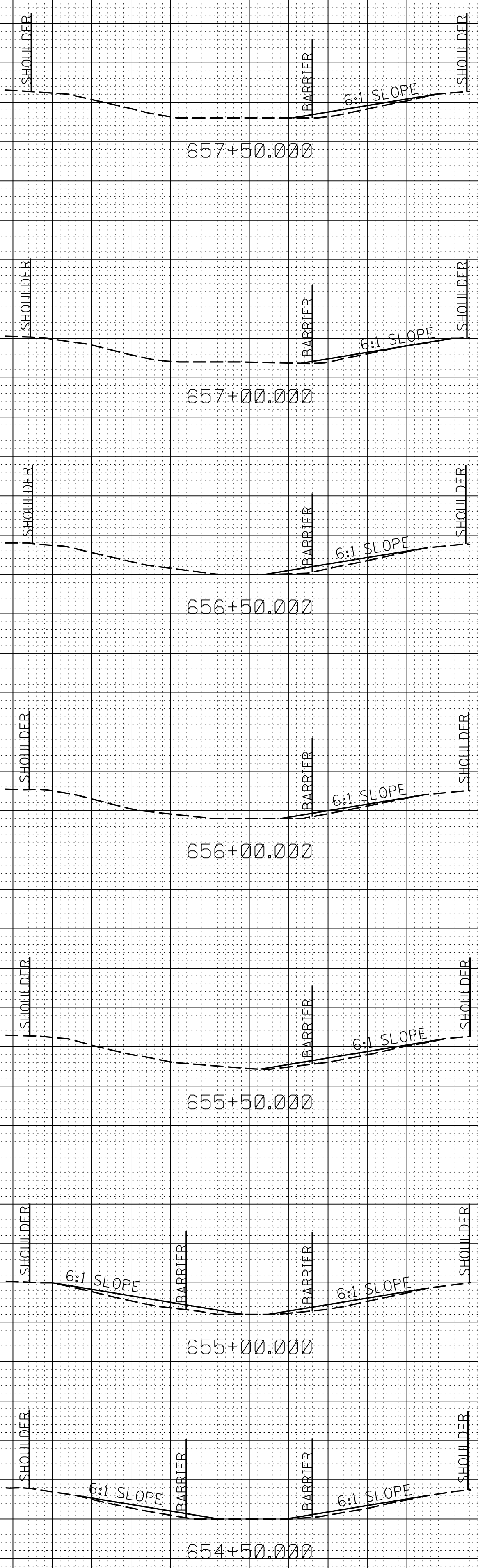

445
440
435

445
440
435

445
440
435

440
435
430

440
435
430

440
435
430

440
435
430
425

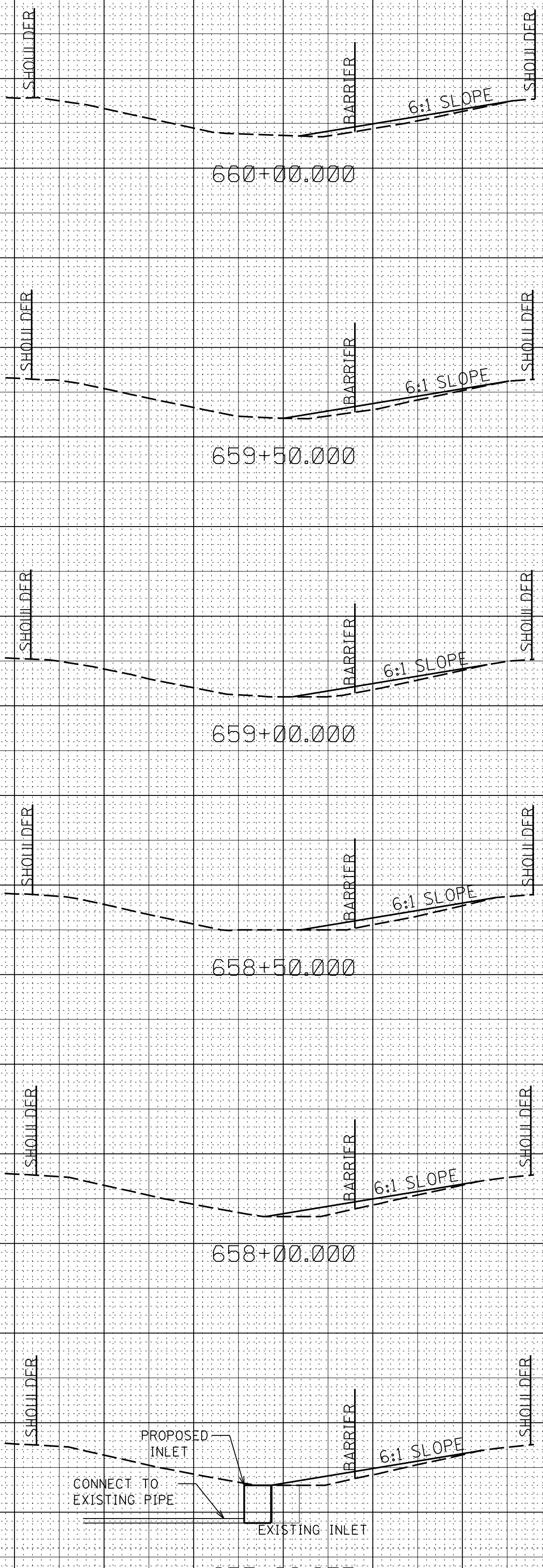

7/30/2019 8:34 AM LAY-COPI-AH2.DGN

80 60 40 20 0 20 40 60 80 80 60 40 20 40

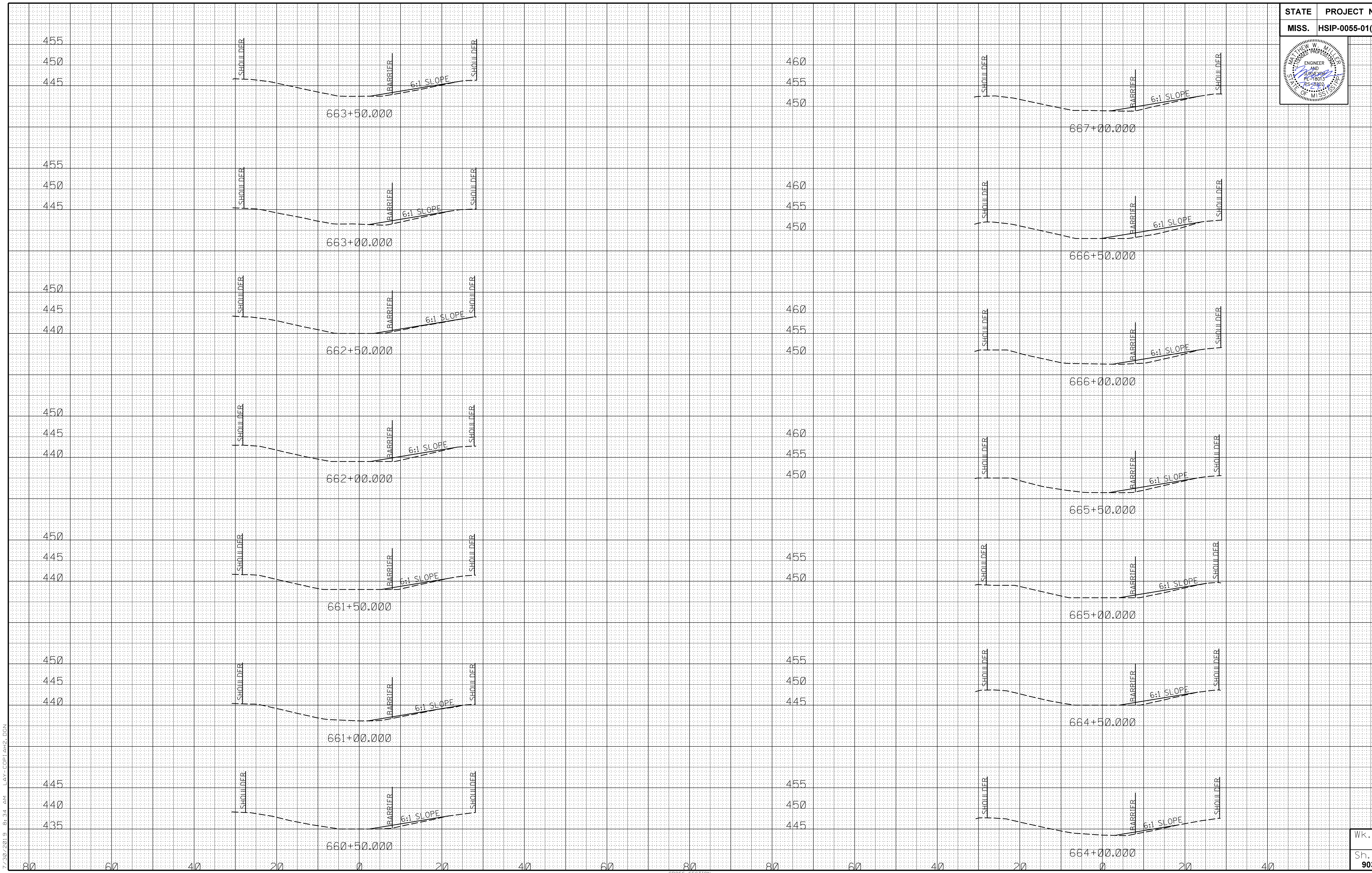
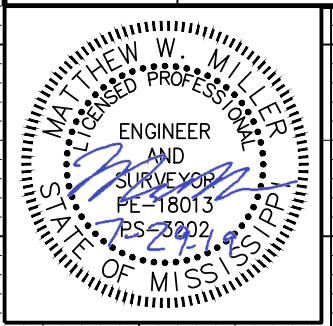

7/30/2019 8:34 AM LAY-COPI-AH2.DGN

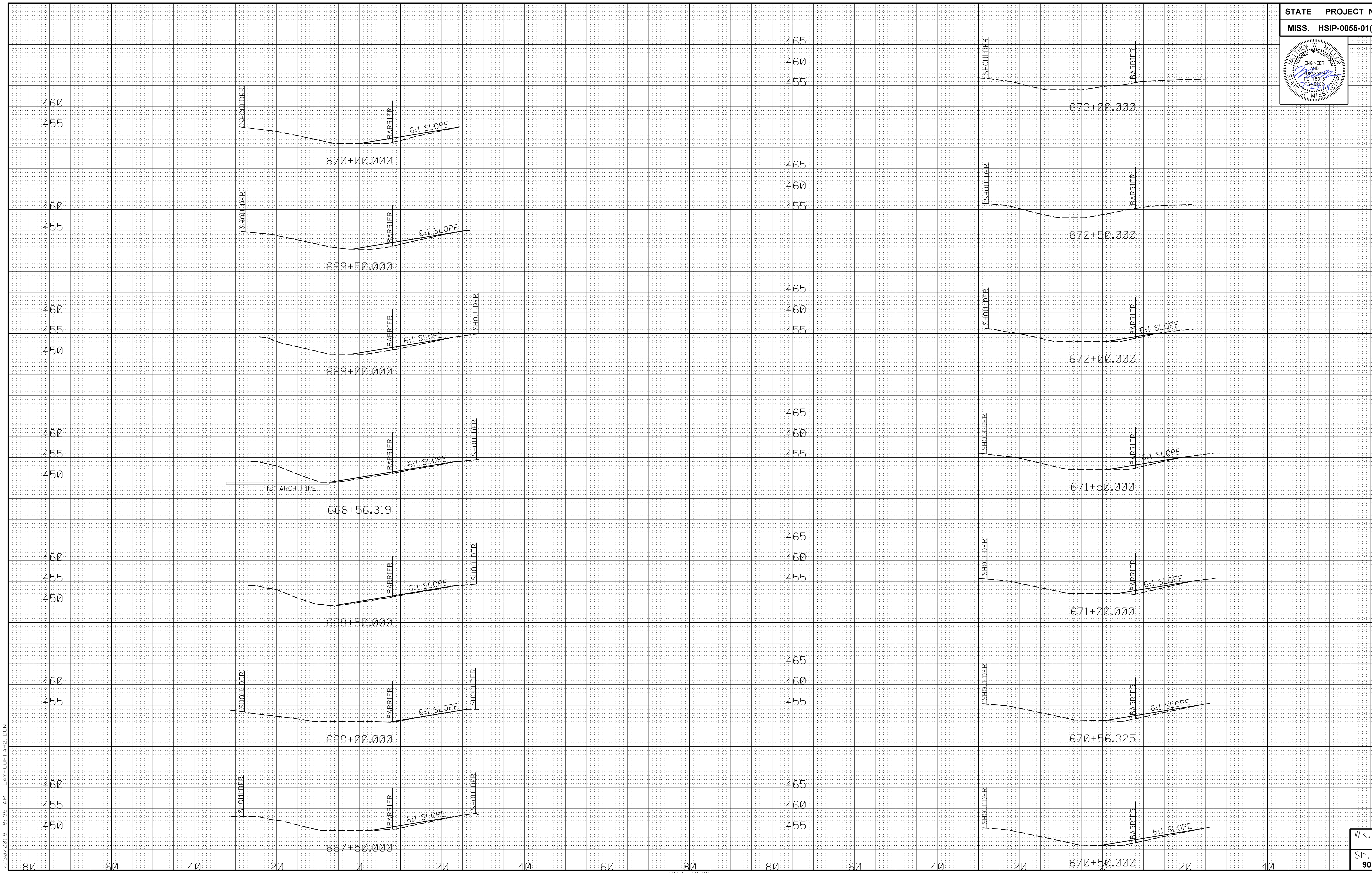
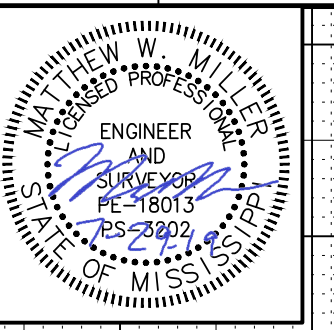

7/30/2019 8:35 AM LAY-COPI-AH2.DGN

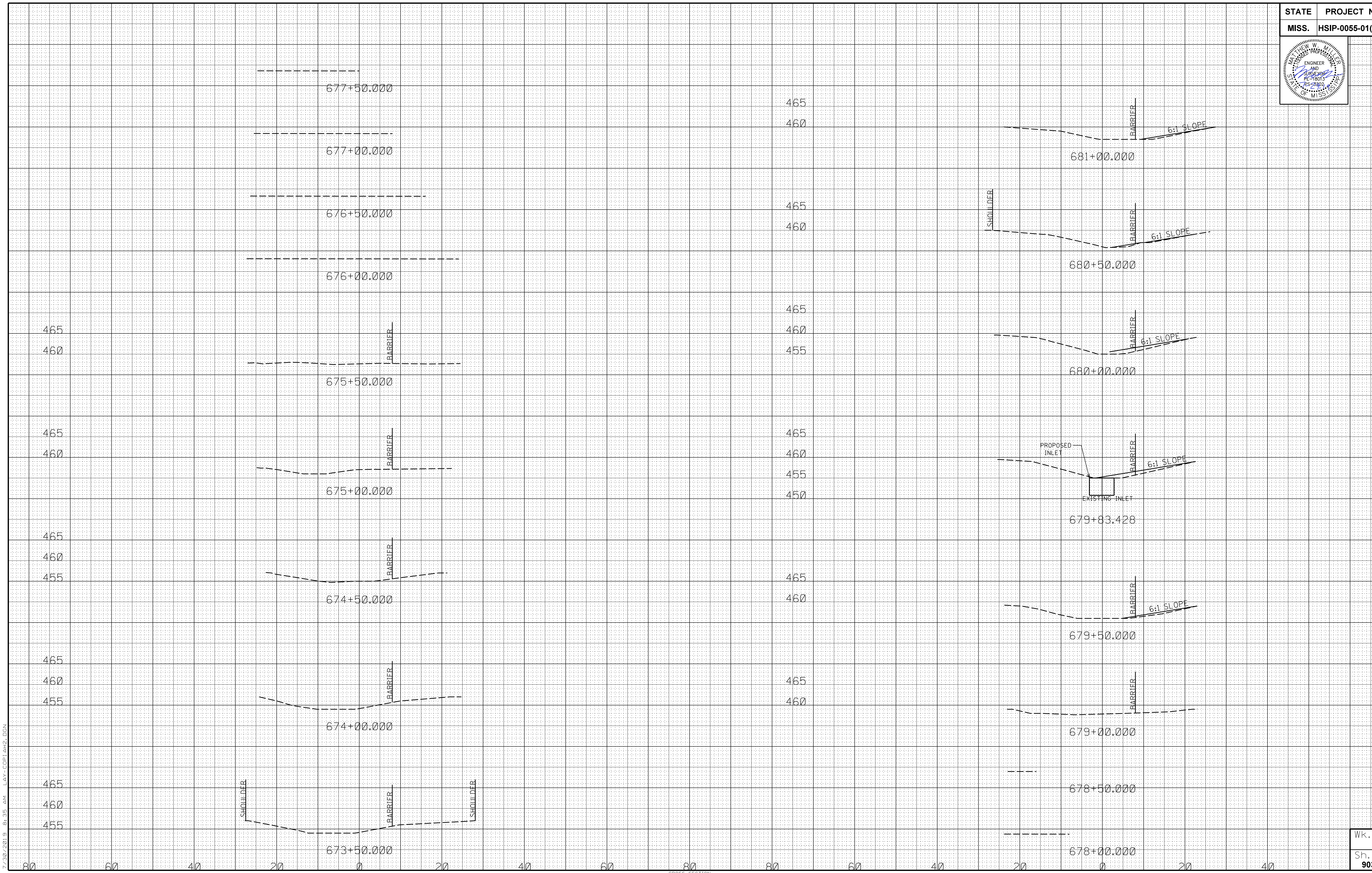
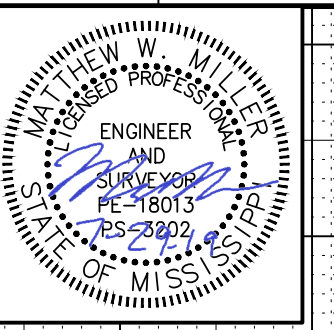

7/30/2019 8:35 AM LAY-COPI-AH2.DGN

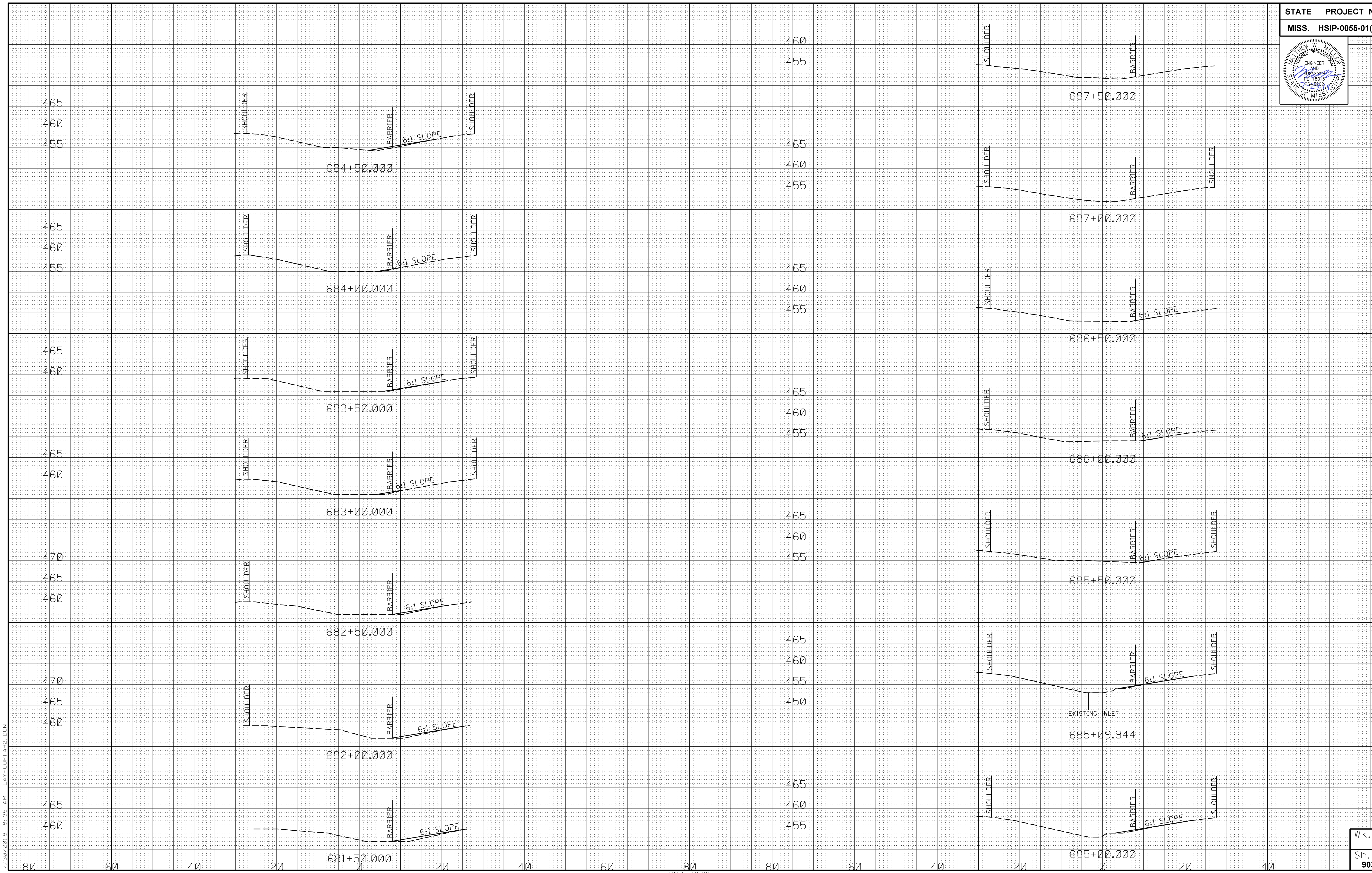
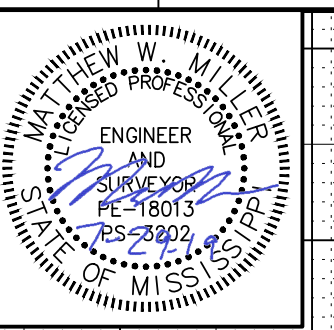

7/30/2019 8:35 AM LAY-COPI-AH2.DGN

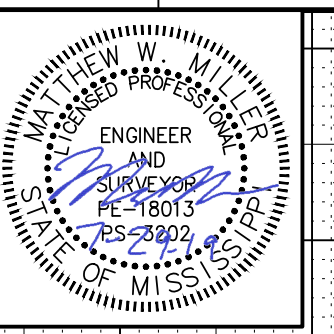

460
455
450

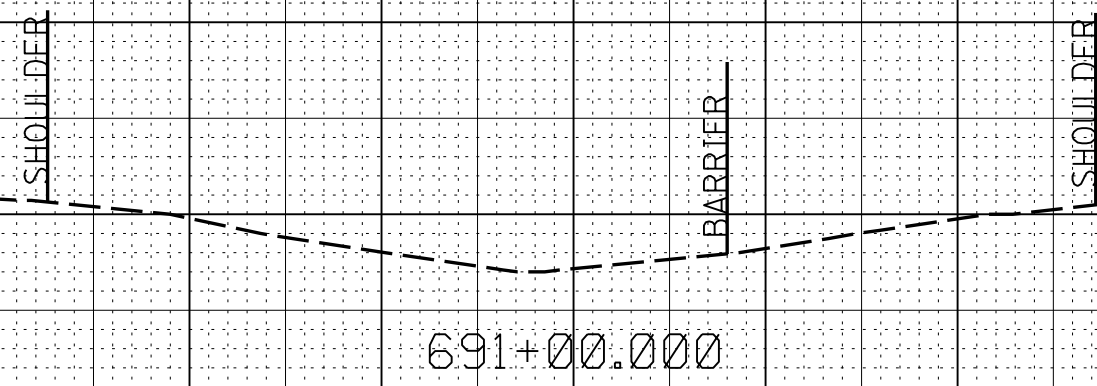

460
455
450

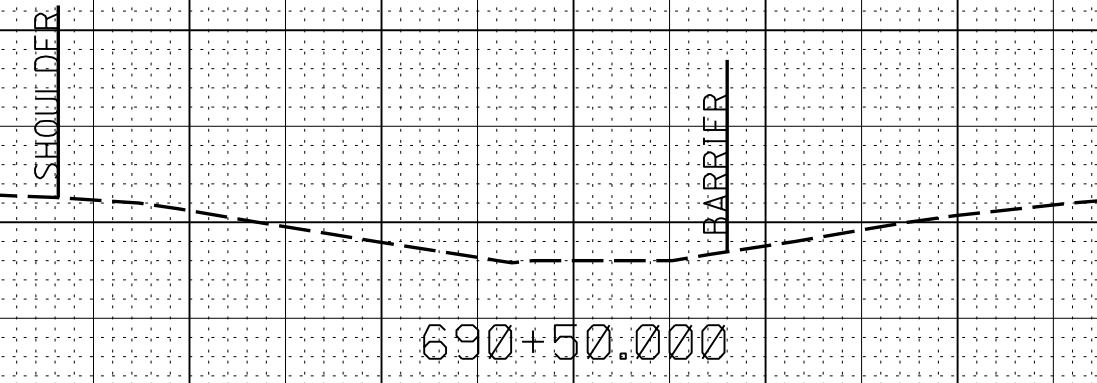

460
455
450

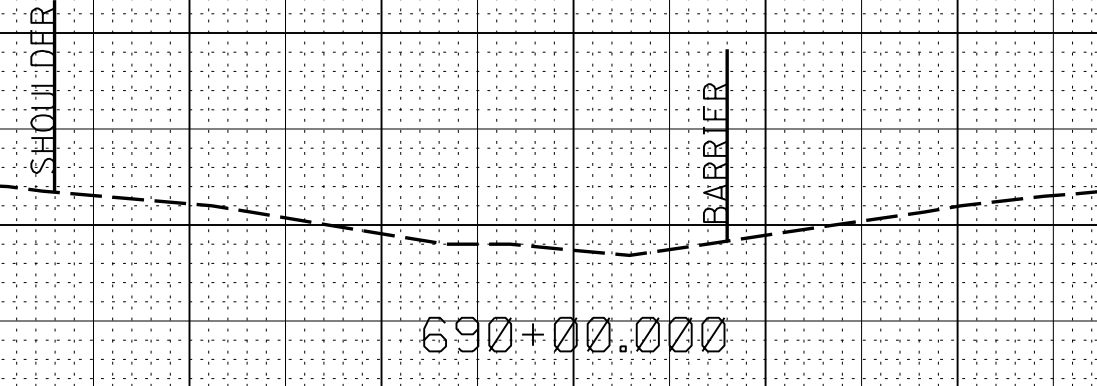

460
455
450

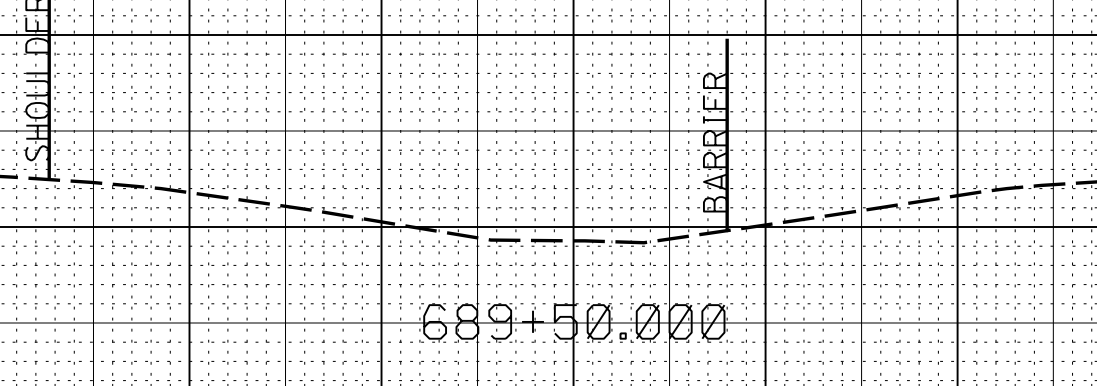

460
455
450

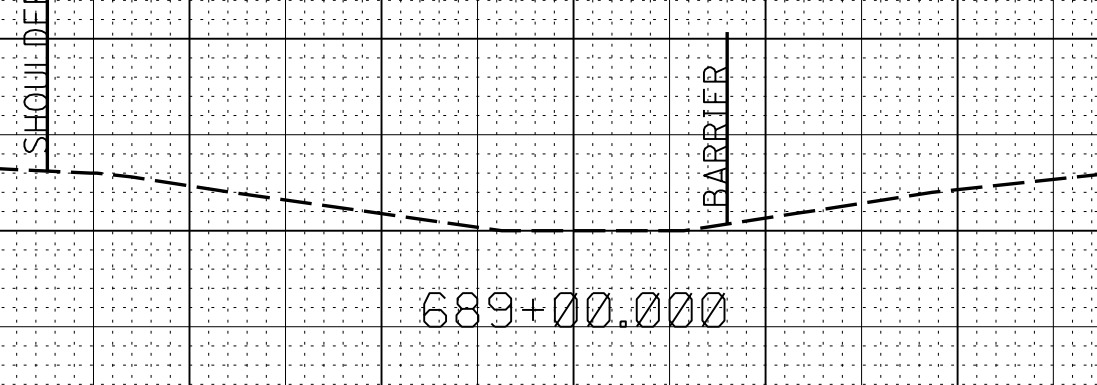

460
455

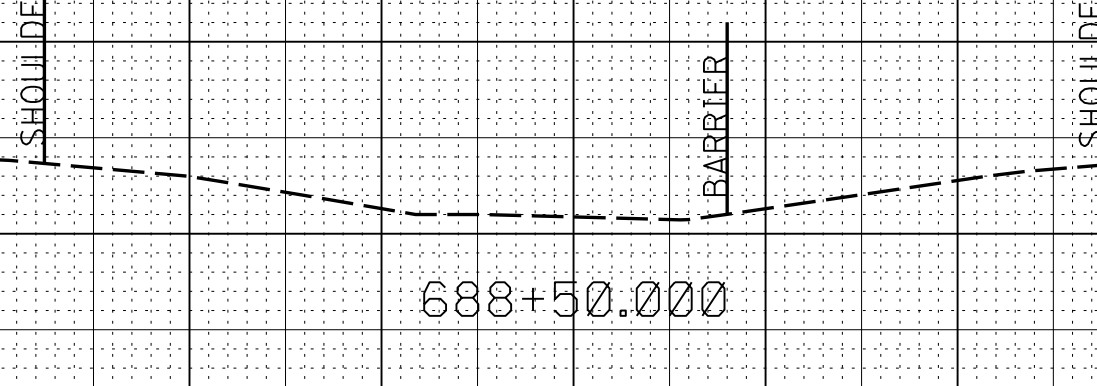

460
455

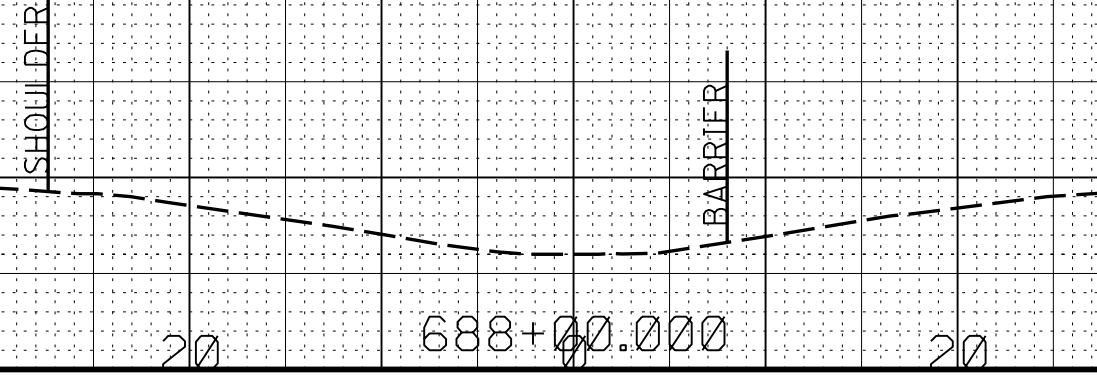

455
450
445

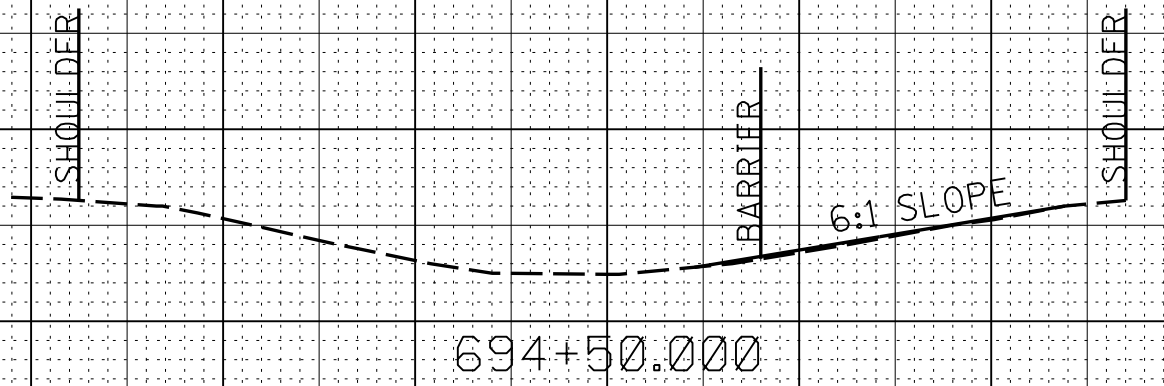

455
450
445

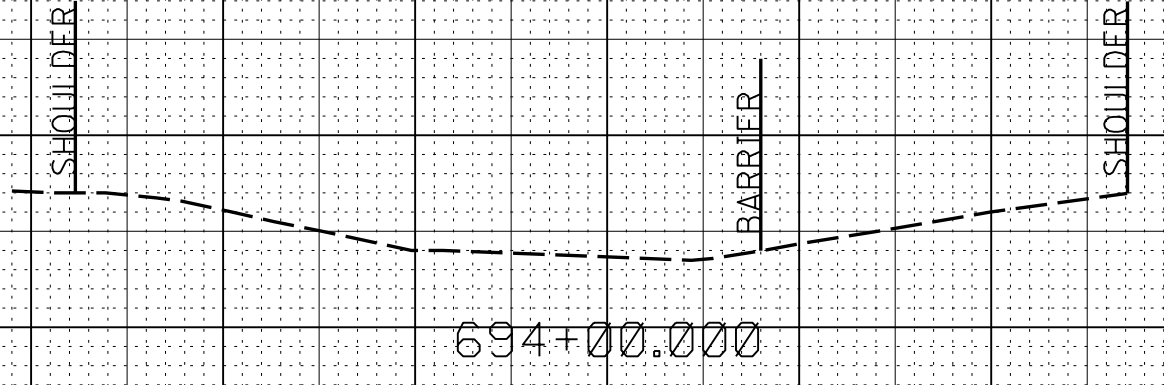

455
450
445

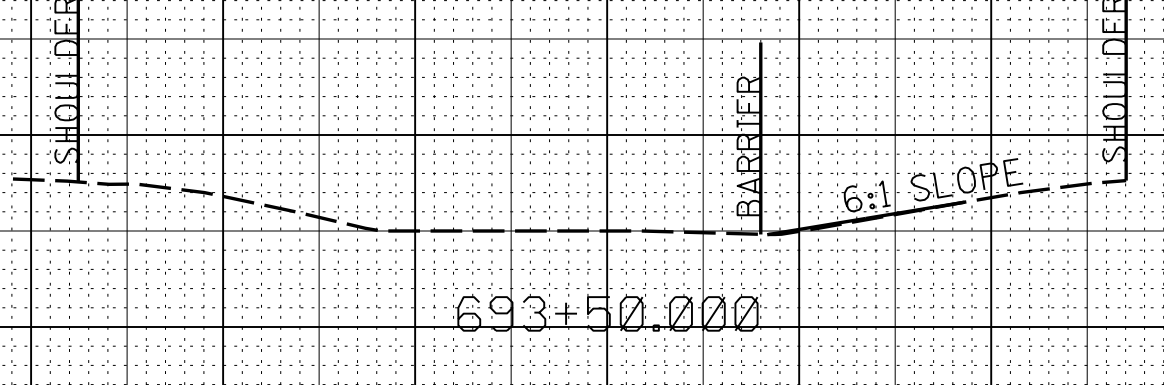

455
450

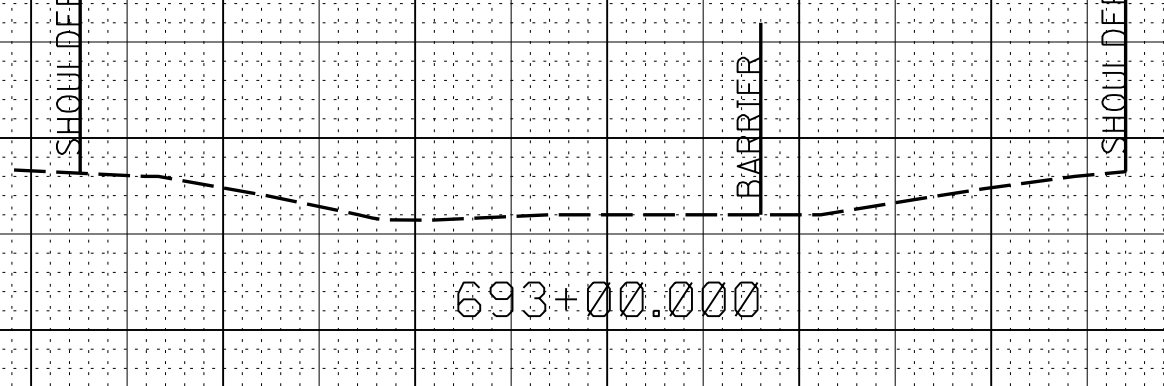

455
450

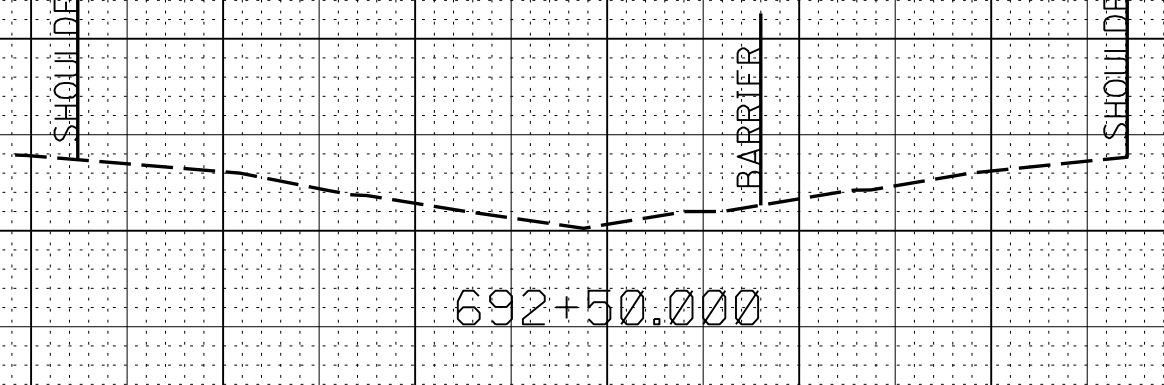

455
450

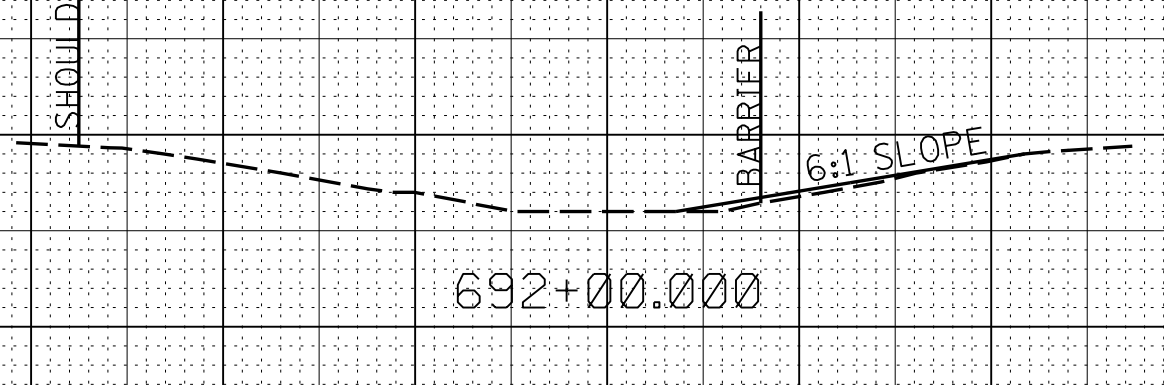

460
455
450

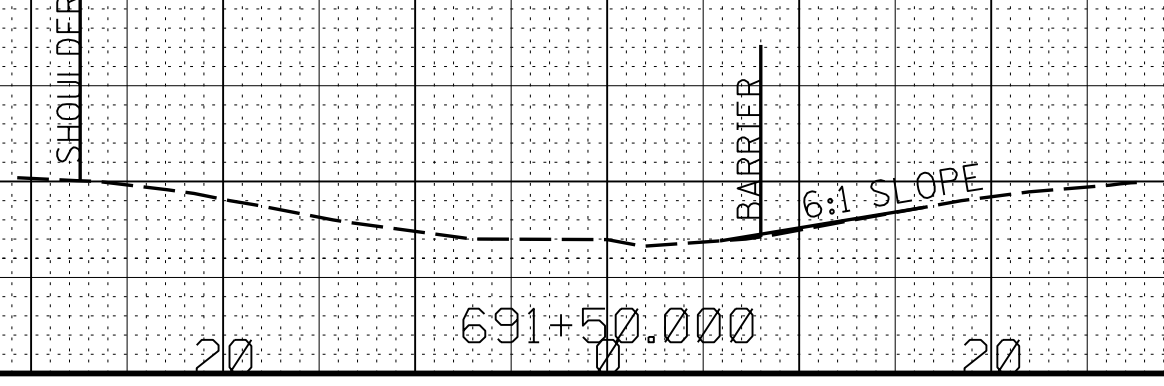

7/30/2019 8:35 AM LAY-COPI-AH2.DGN

80 60 40 20 688+00.000 20 40 60 80 80 60 40 20 691+50.000 20 40

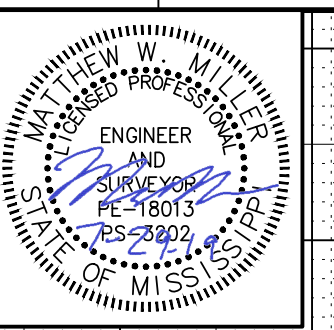

7/30/2019 8:35 AM LAY-COPI-AH2.DGN

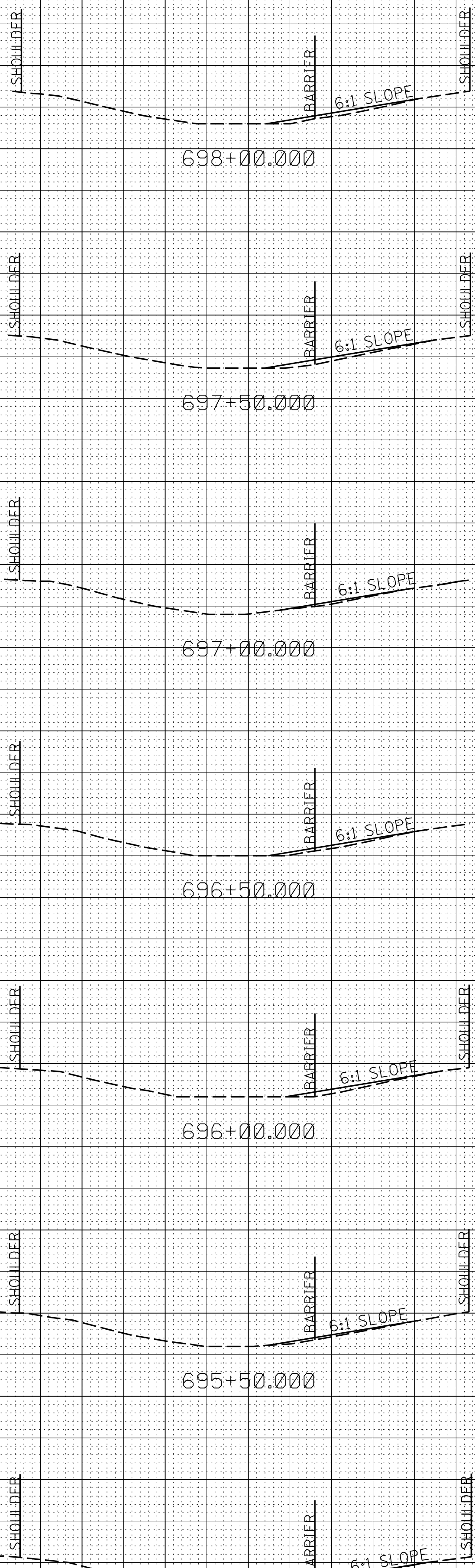

445
440
435
445
440
435
445
440
435
450
445
440
450
445
440
450
445
440

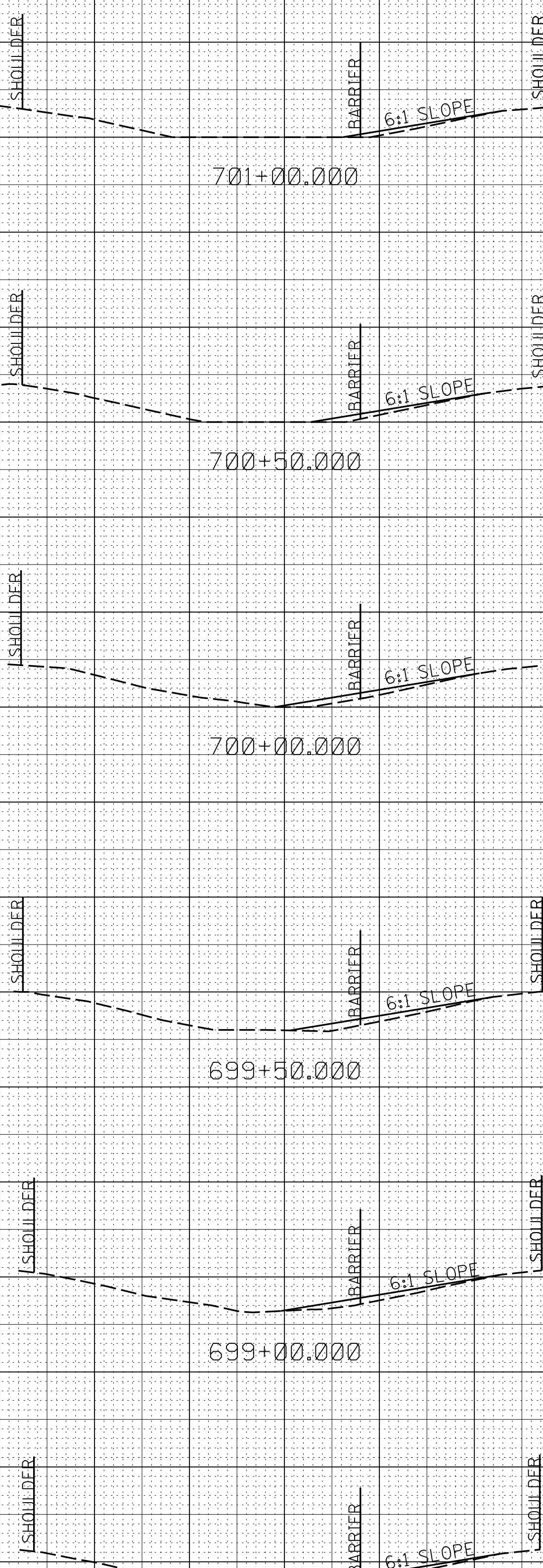

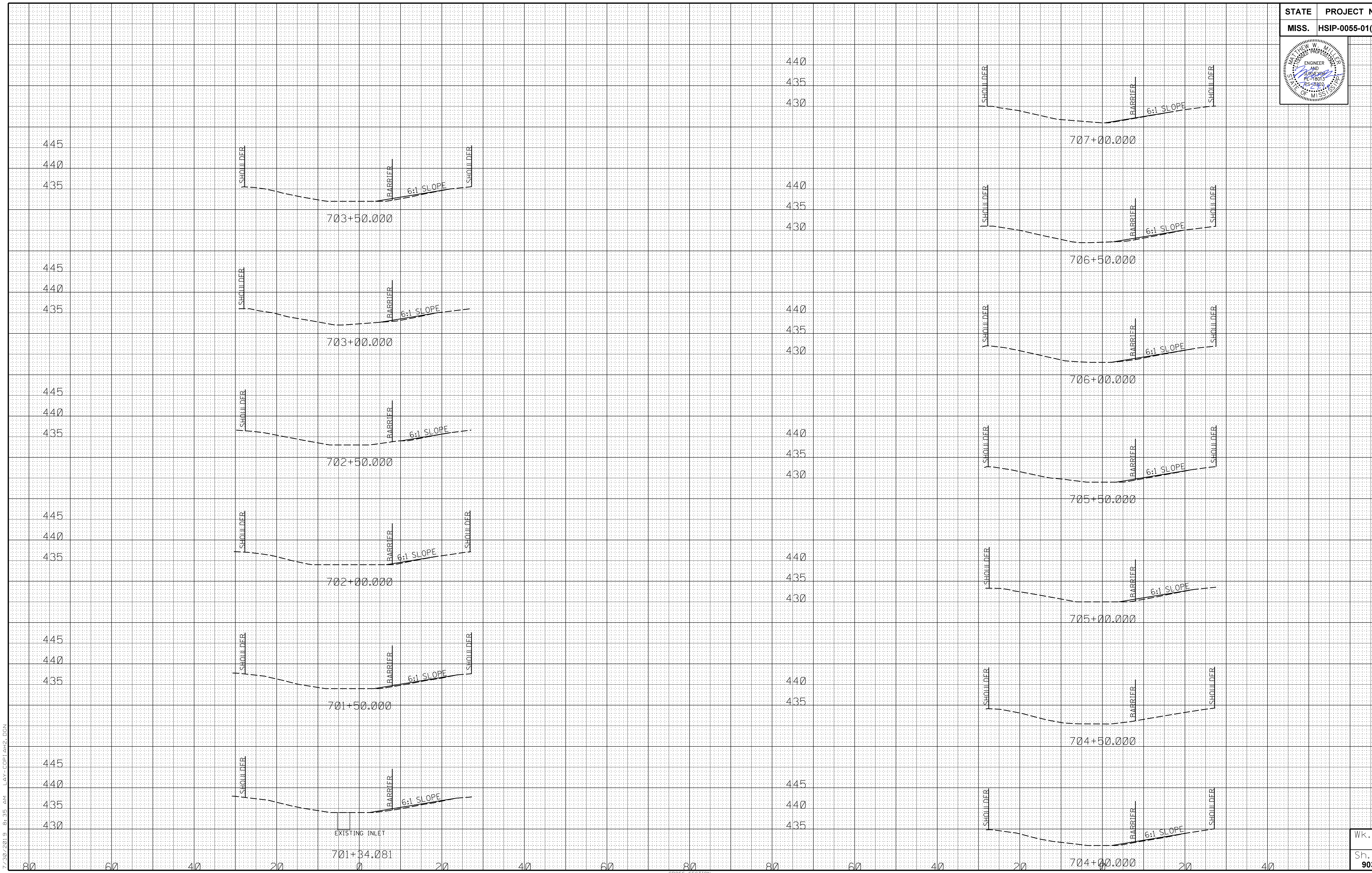
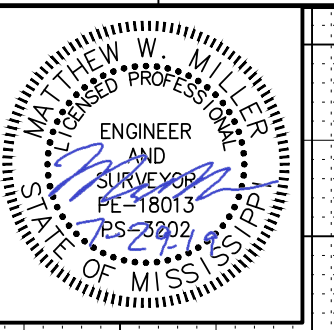

7/30/2019 8:35 AM LAY-COPI-AH2.DGN

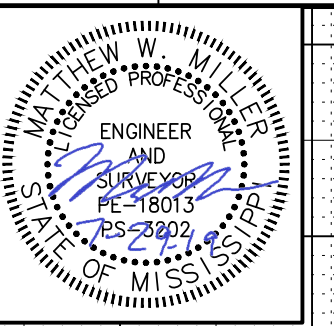

430
425
435
430
425
435
430
425
435
430
425
435
430
425
435
430
425
435
430
425

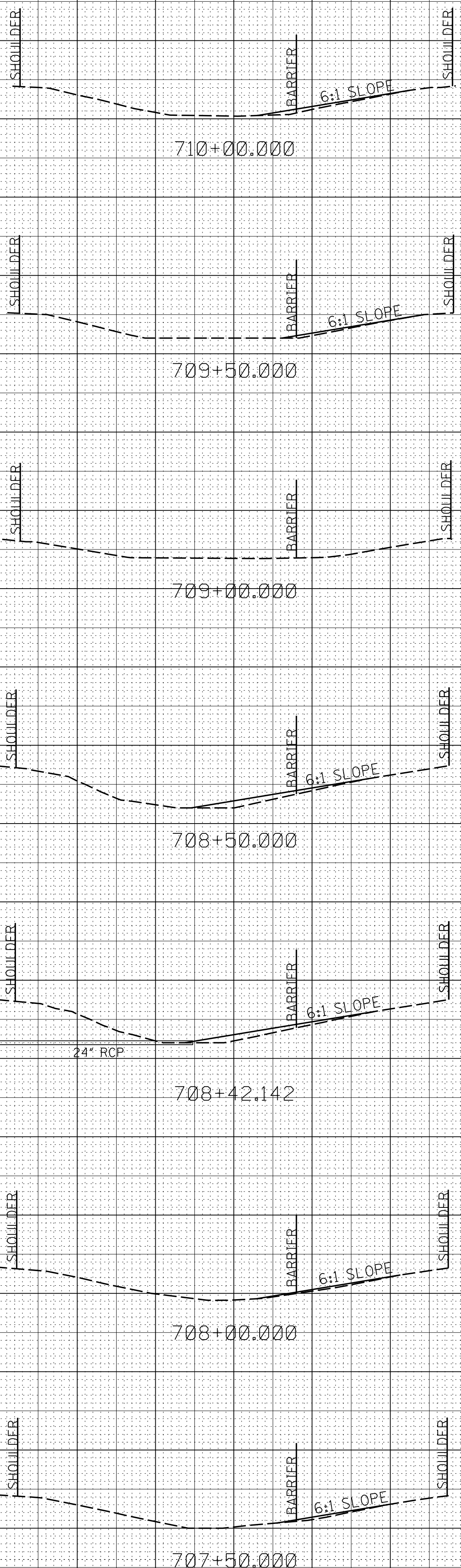

425
420
415
425
420
415
425
420
415
430
425
420
430
425
420
430
425
420

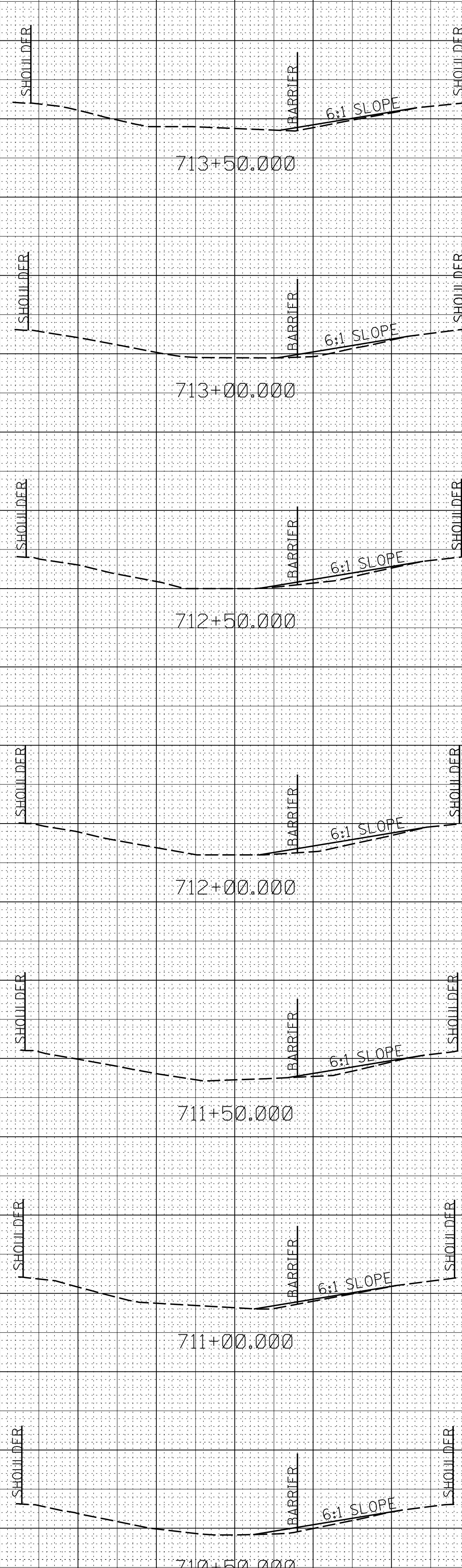

7/20/2019 8:35 AM LAY-COPI-AH2.DGN

80 60 40 20 0 20 40 60 80 80 60 40 20 40

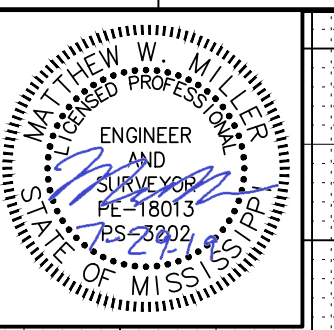

420
415
410
420
415
410
420
415
410
420
415
410
420
415
410
425
420
415
425
420
415

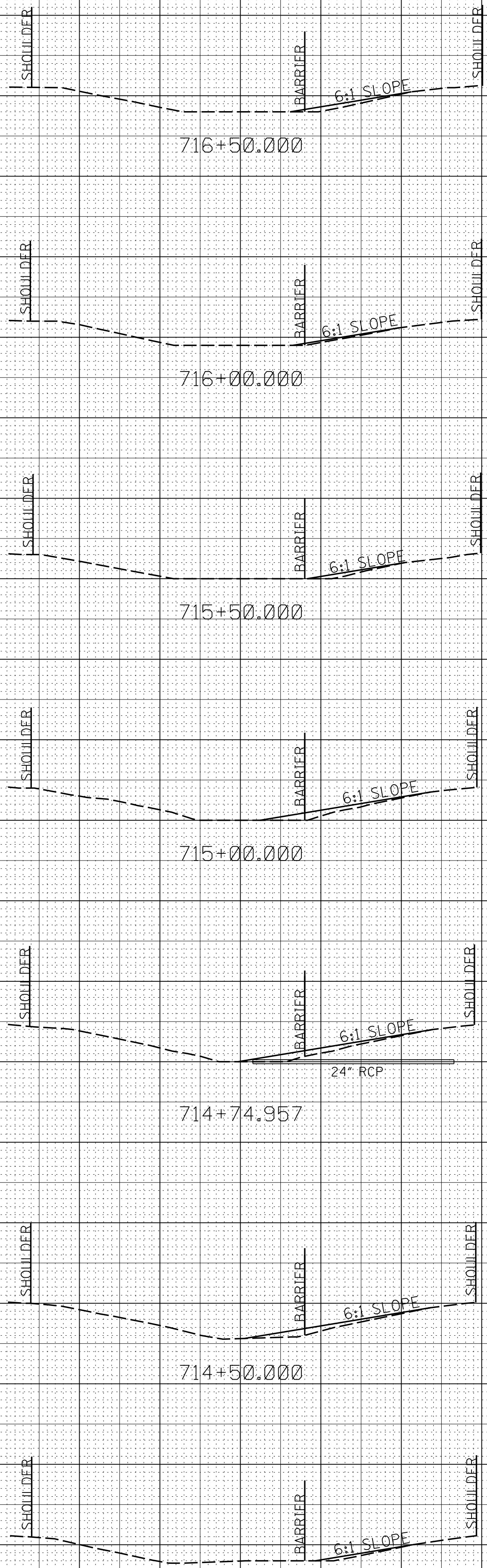

410
405
415
410
405
415
410
405
415
410
405
415
410
405
420
415
410

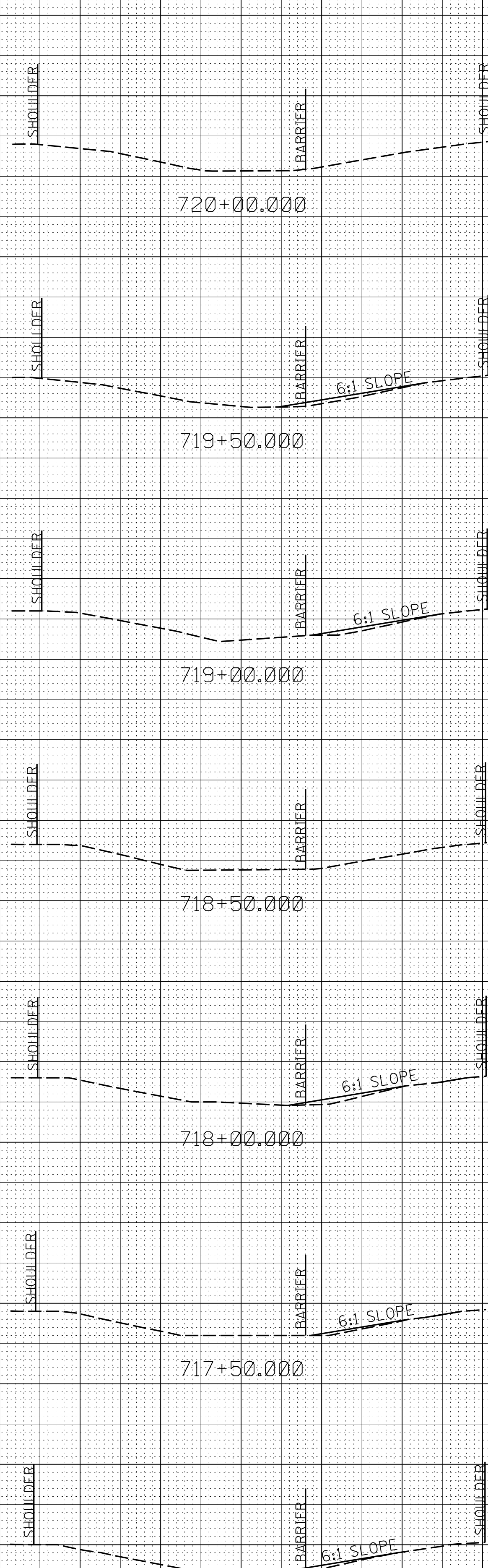

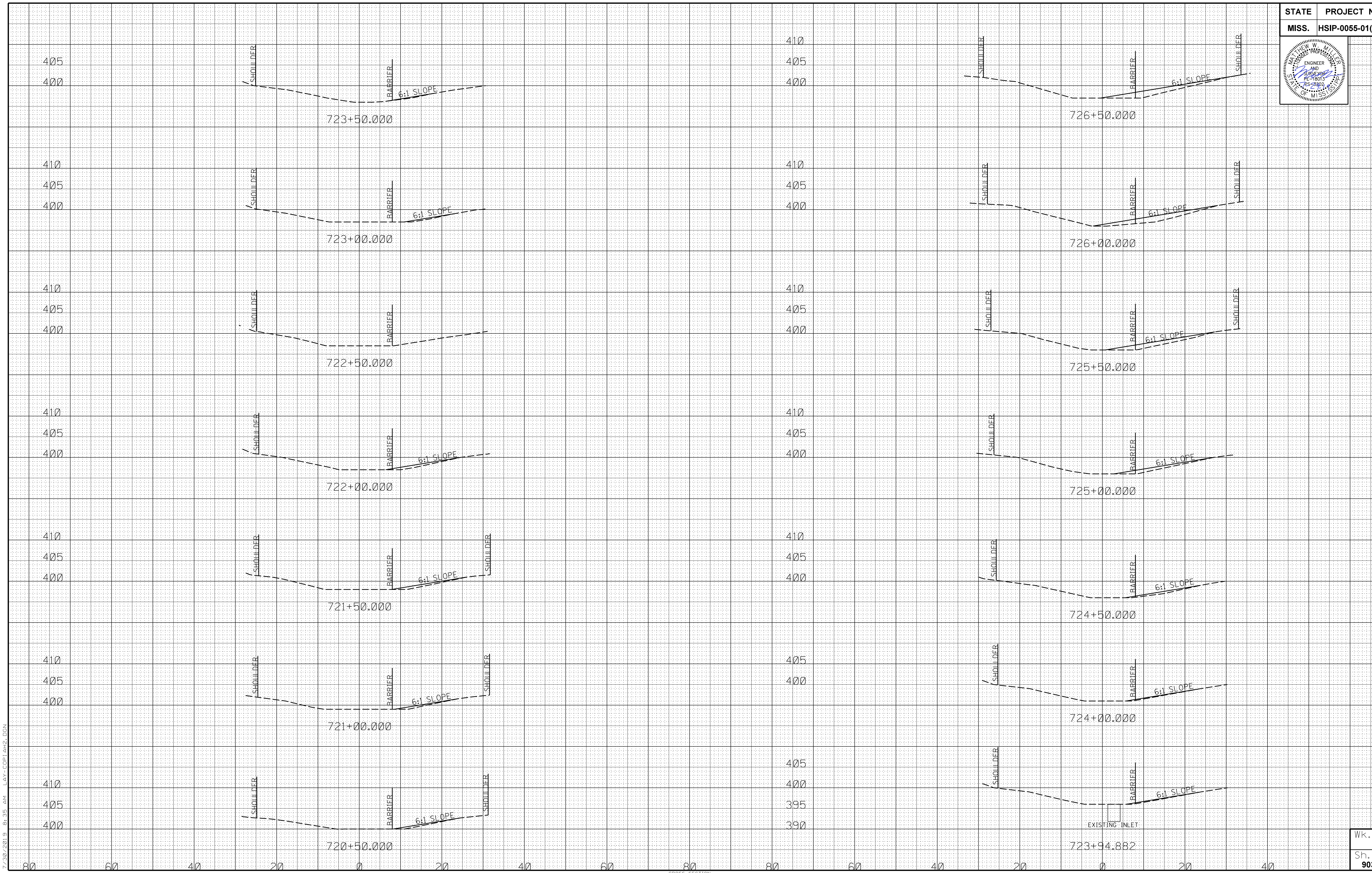
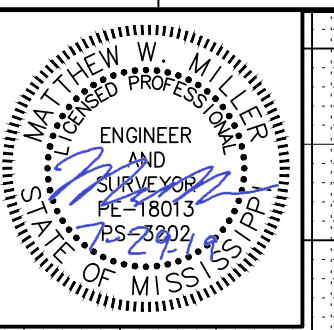

7/30/2019 8:35 AM LAY-COPI-AH2.DGN

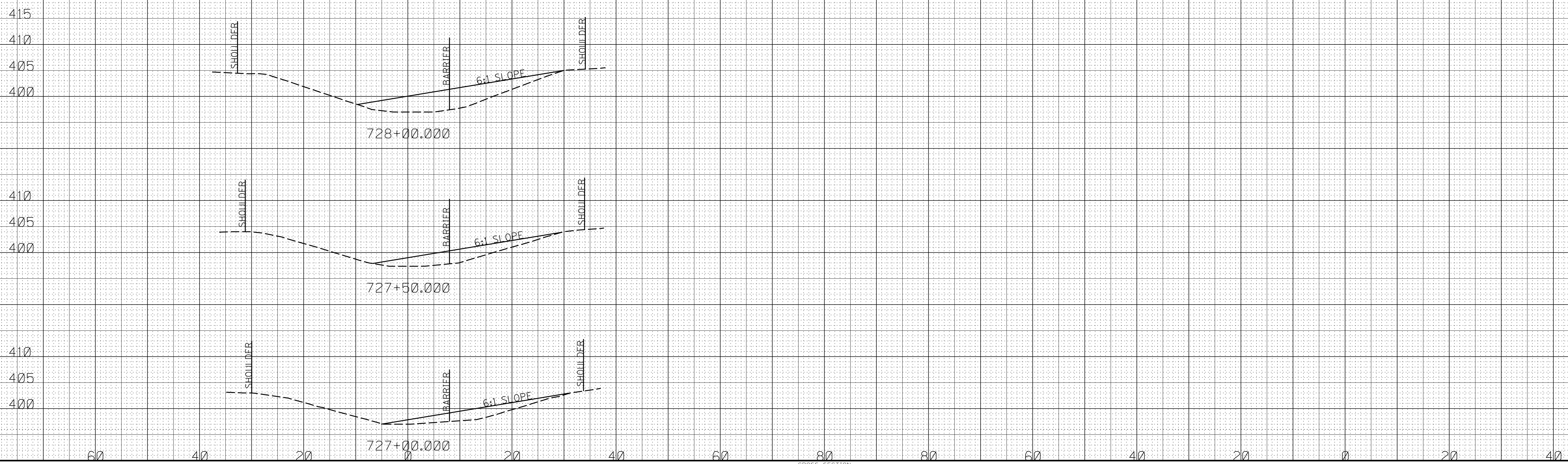
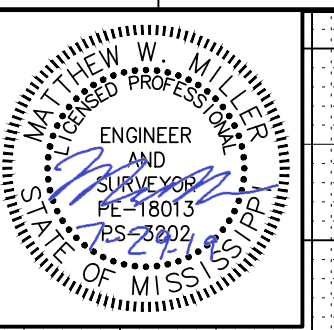

7/30/2019 8:35 AM LAY-COPI-AH2.DGN

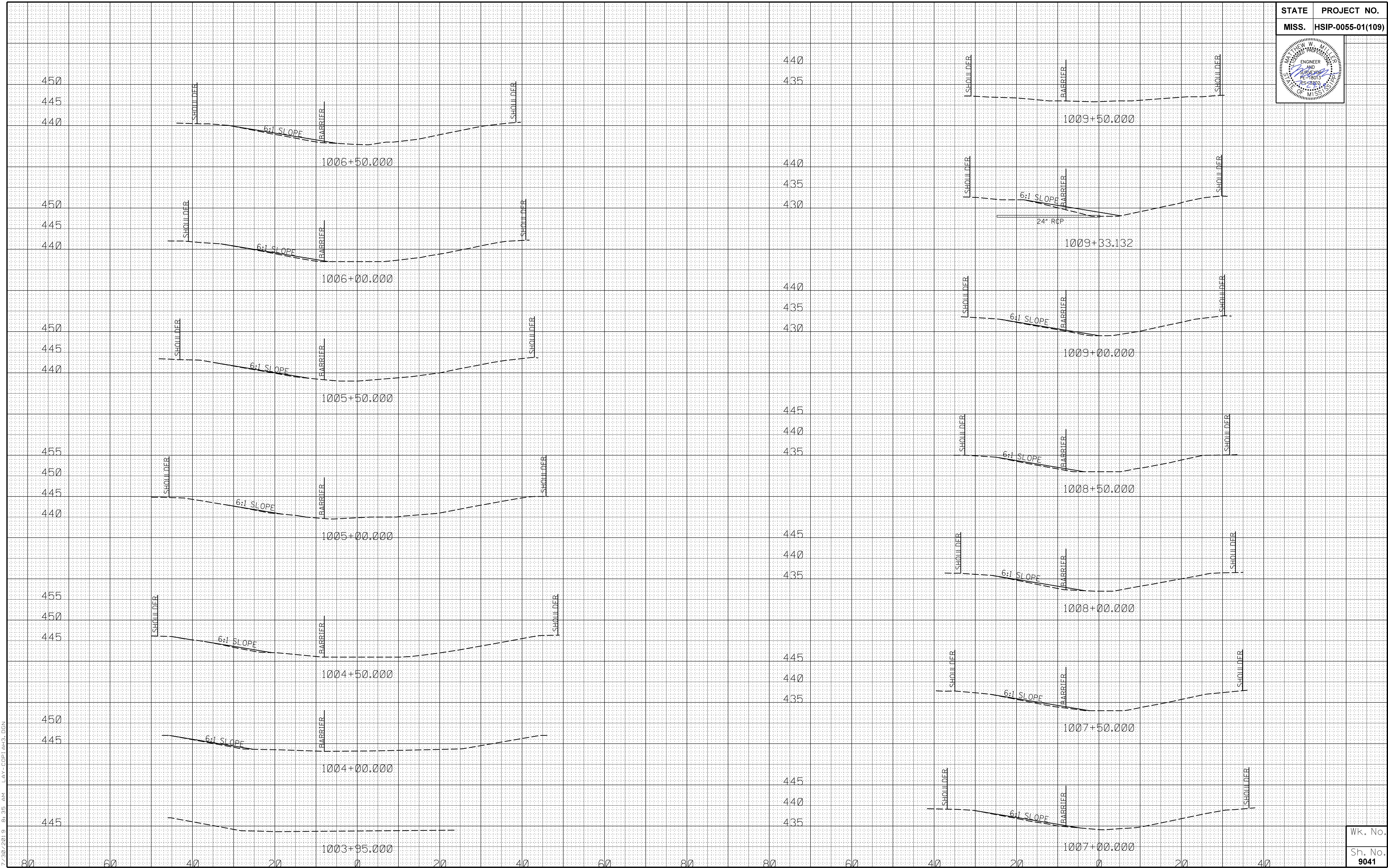
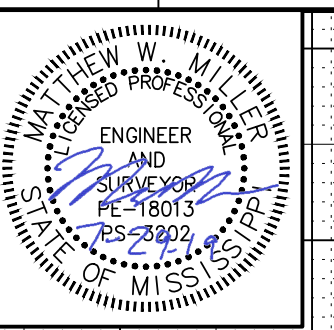

7/30/2019 8:35 AM LAY-COPI-AH3.DGN

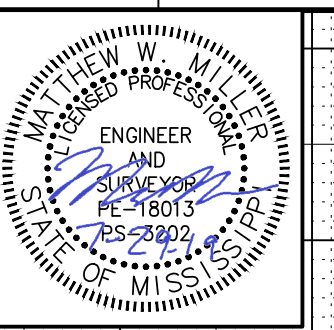

430
425
420
430
425
420
435
430
425
435
430
425
435
430
425
435
430
425
440
435
430

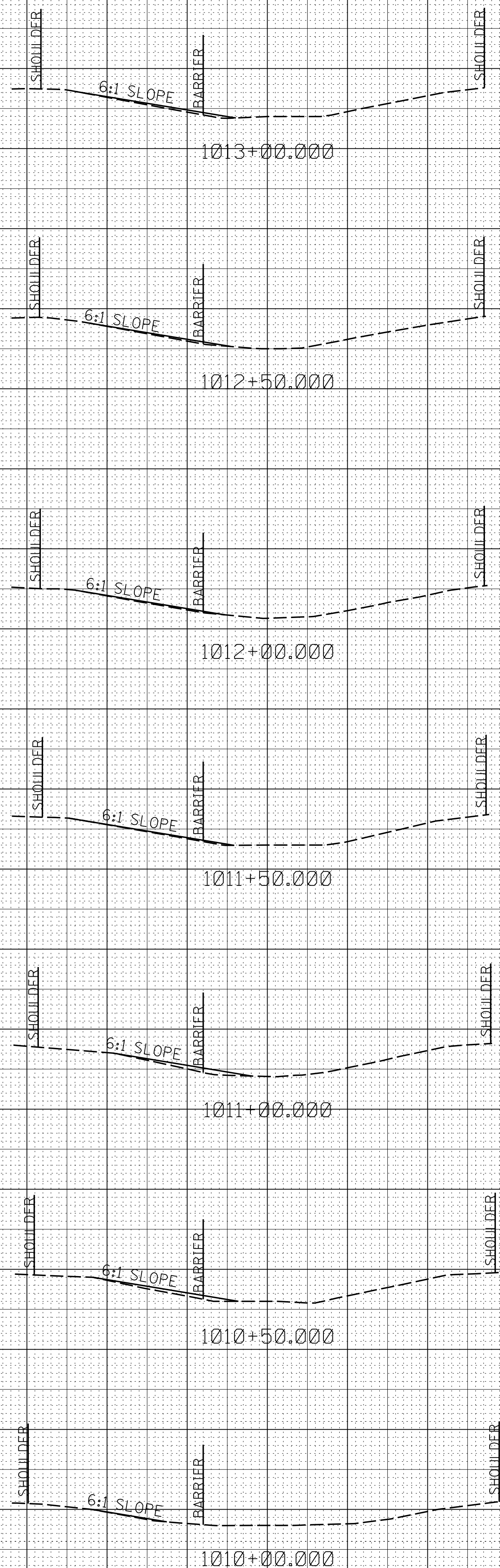

420
415
410
420
415
425
420
415
425
420
415
425
420
415
430
425
420

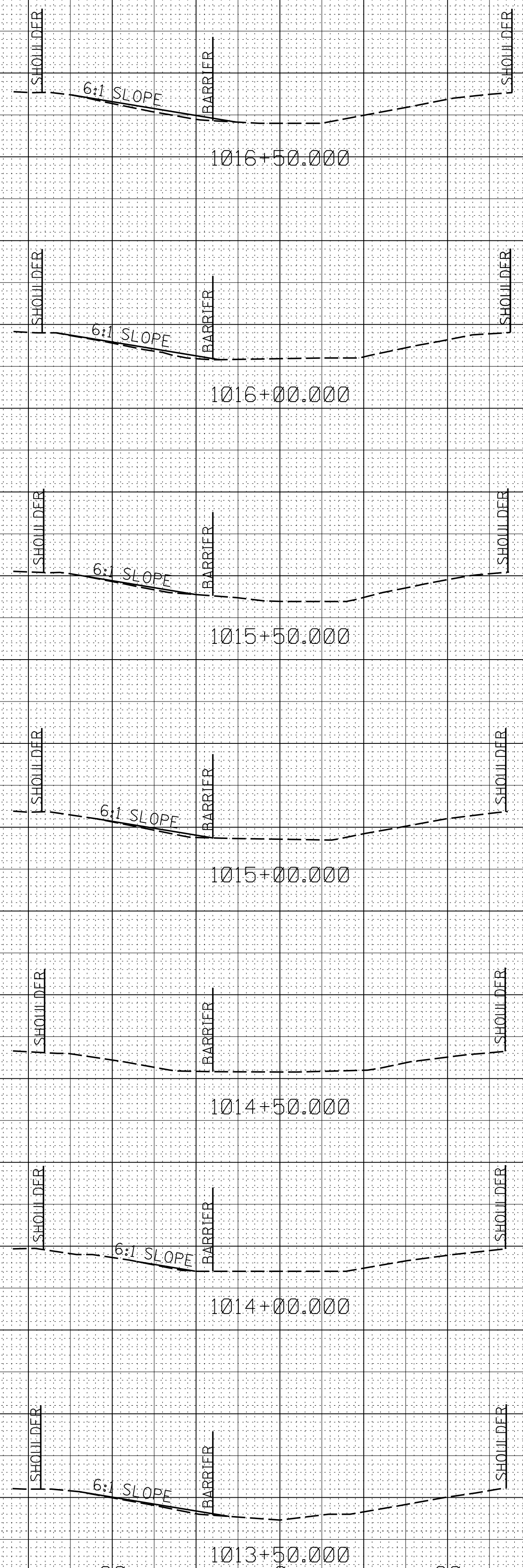

7/30/2019 8:35 AM LAY-COPI-AH3.DGN

80 60 40 20 0 20 40 60 80 80 60 40 20 0 20 40

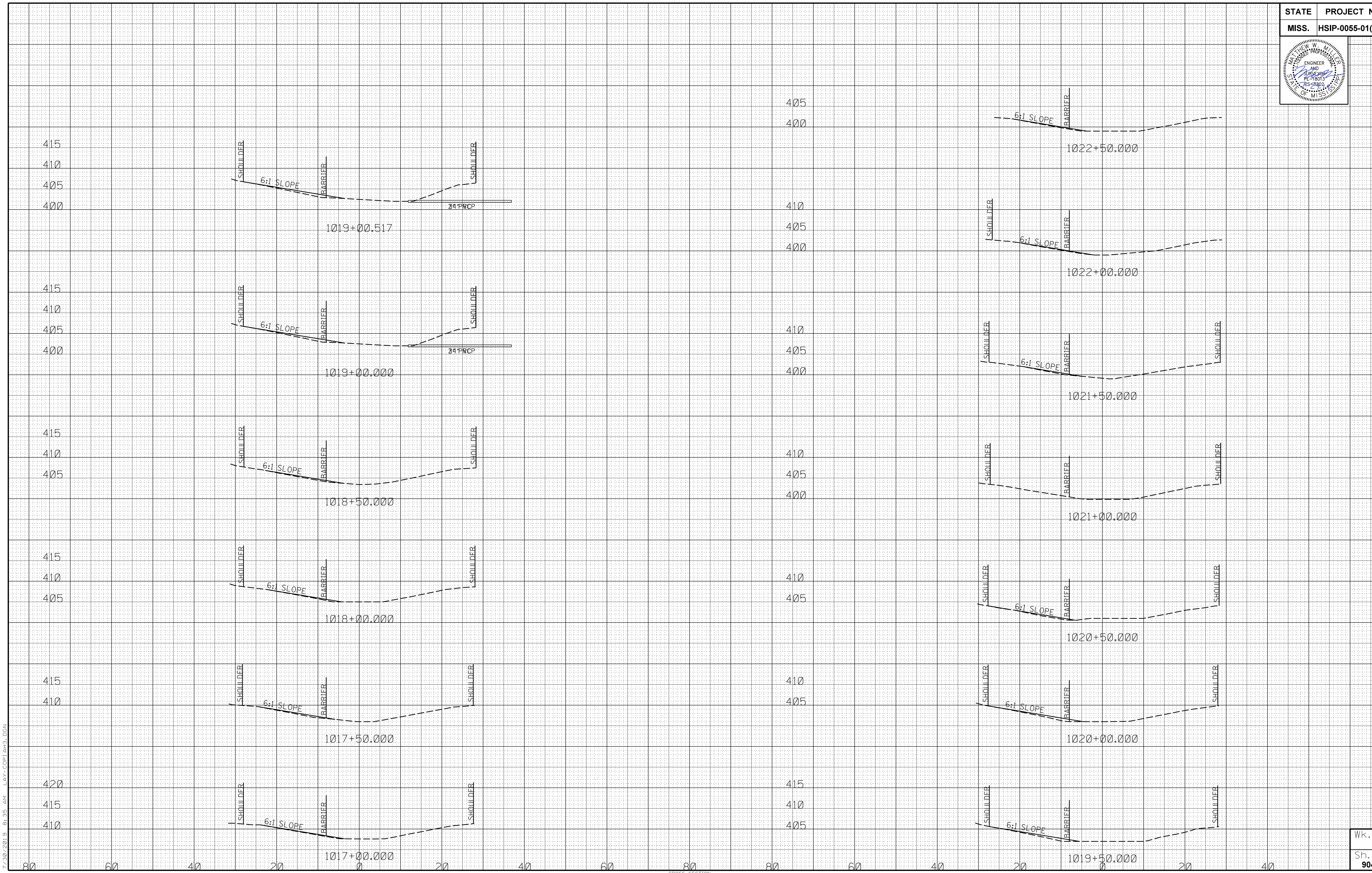
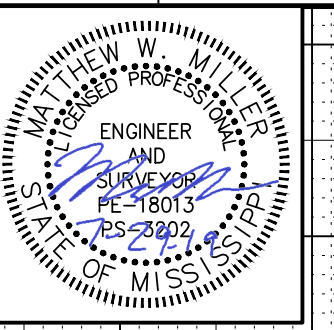

7/30/2019 8:35 AM LAY-COPI-AH3.DGN

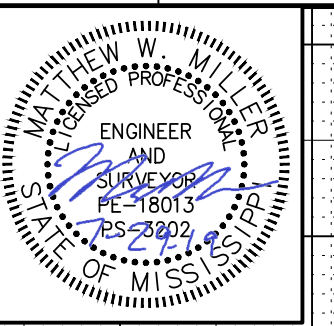

1025+24.369

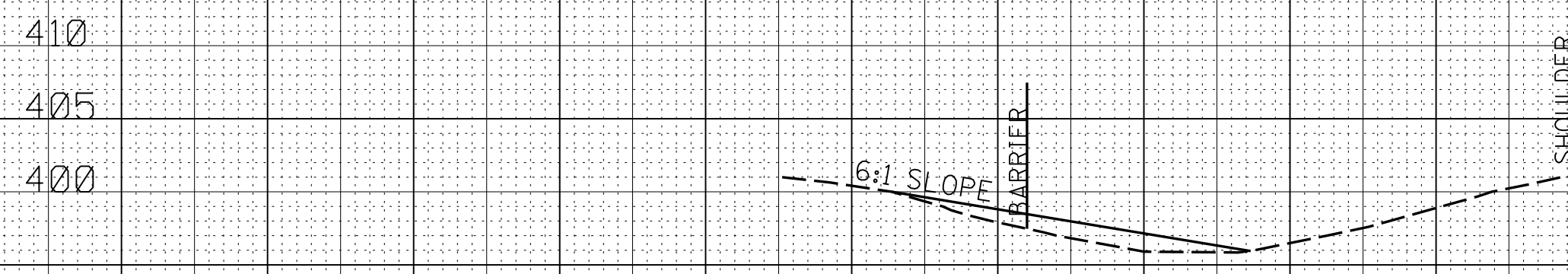

1025+00.000

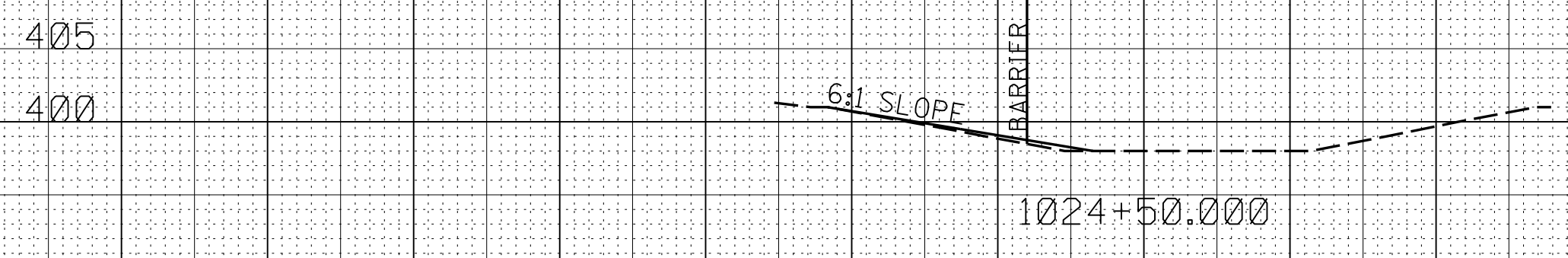

1024+50.000



1024+00.000



1023+50.000

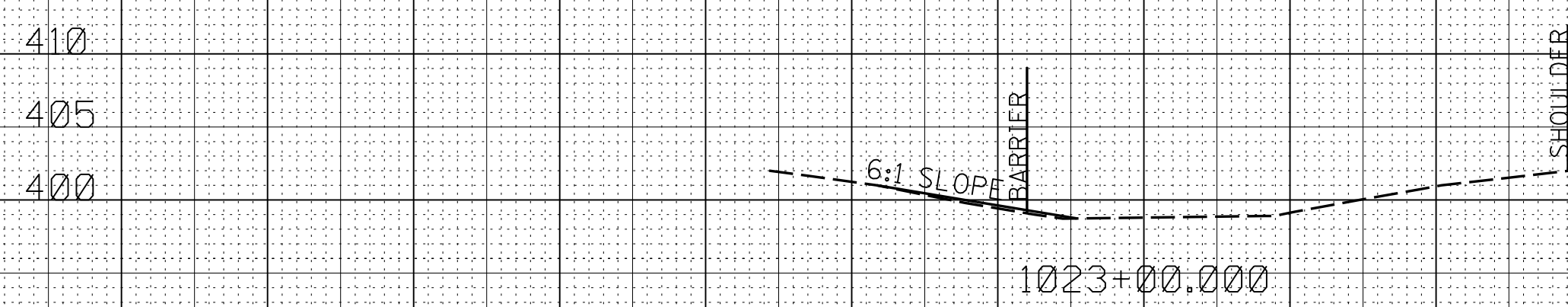

1023+00.000

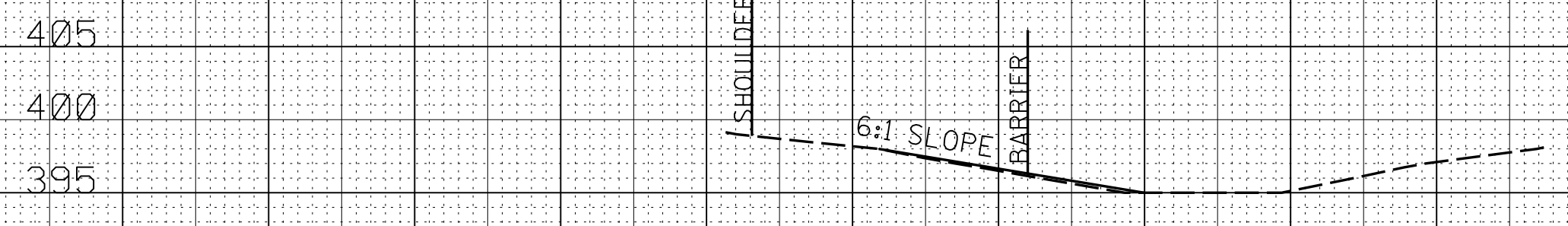

1028+50.000

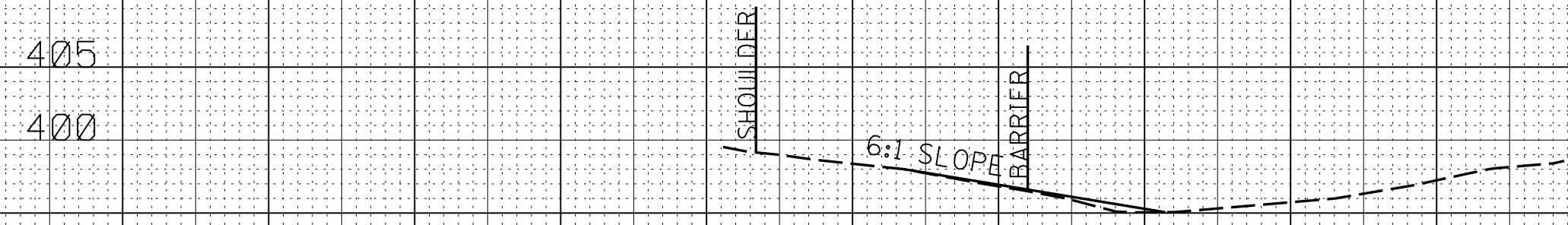

1028+00.000

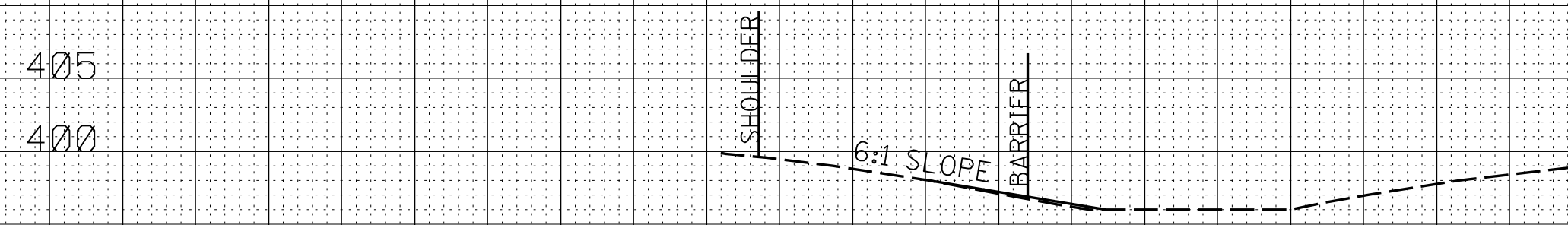

1027+50.000

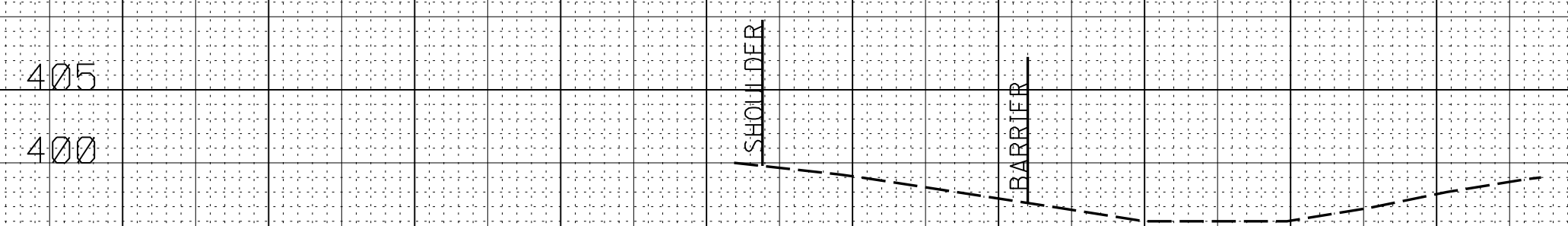

1027+00.000

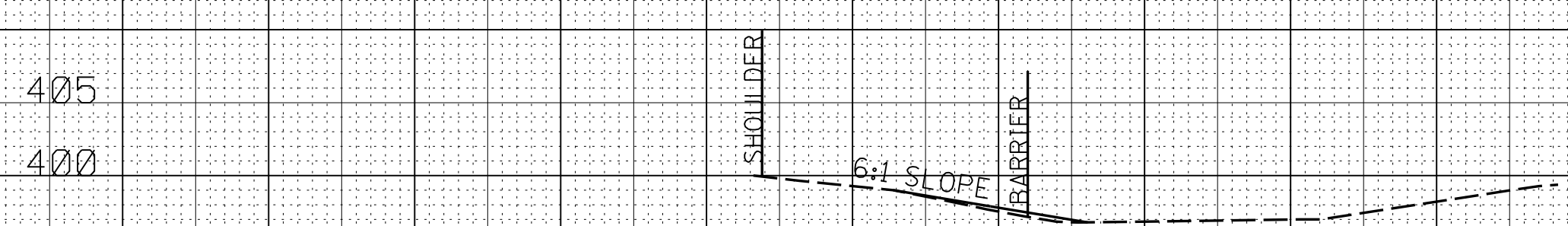

1026+50.000

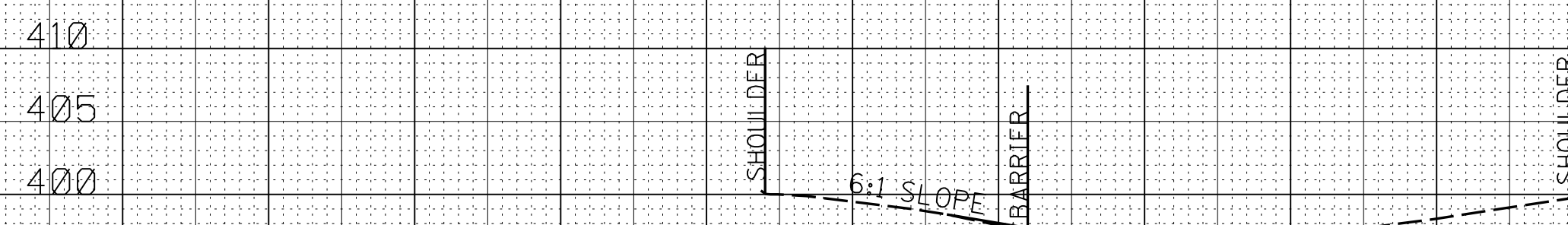

1026+00.000



1025+50.000

7/30/2019 8:35 AM LAY-COPI-AH3.DGN

80 60 40 20 0 20 40 60 80 80 60 40 20 0 20 40

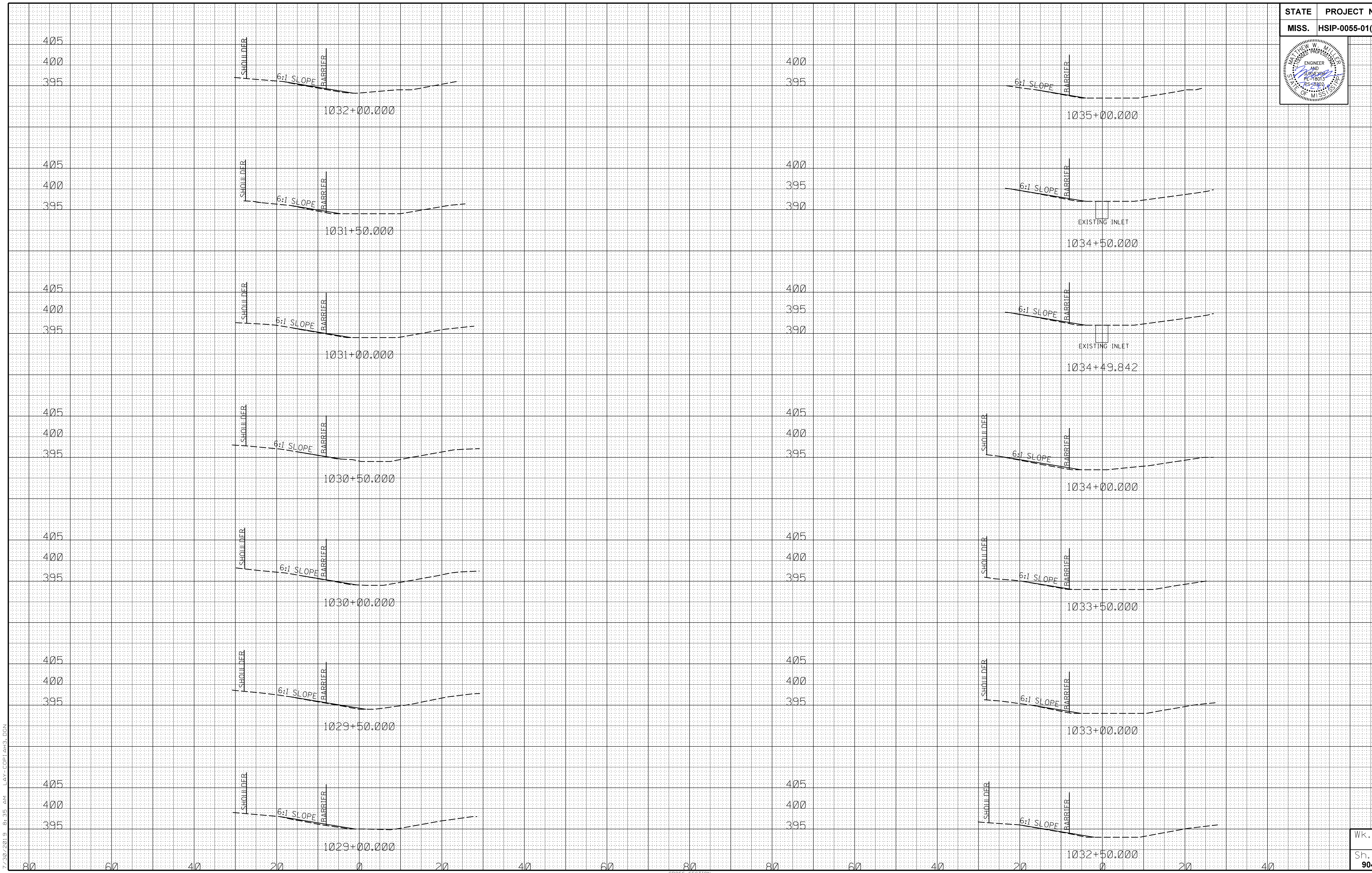
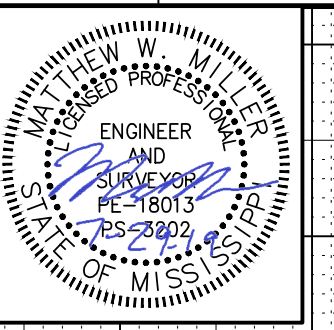

7/30/2019 8:35 AM LAY-COPI-AH3.DGN

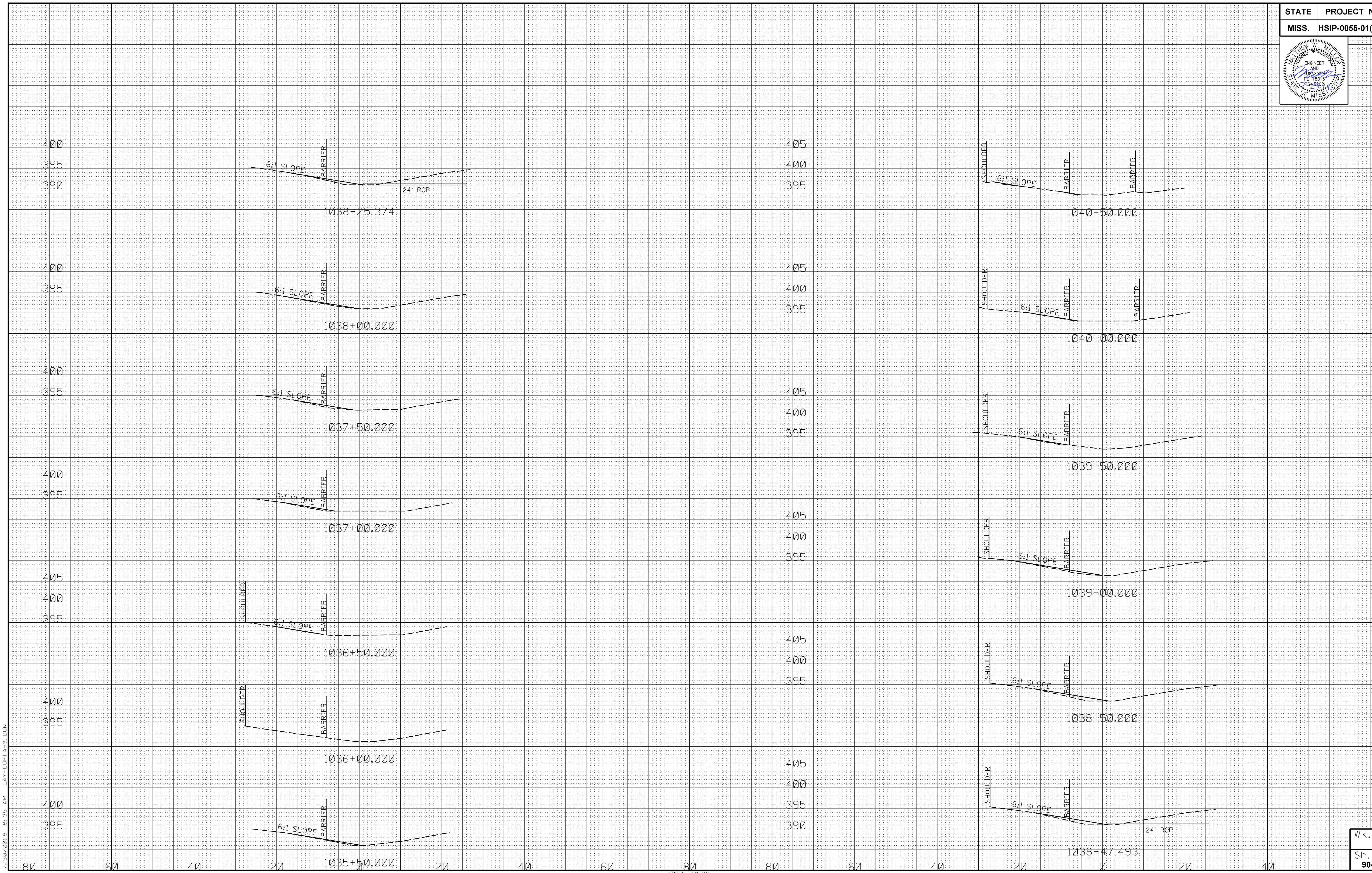
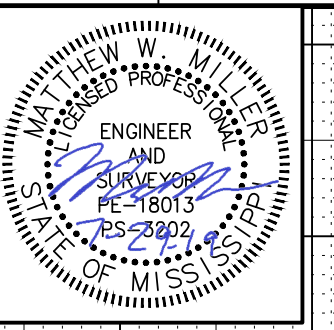

7/26/2019 8:35 AM LAY-COPI-AH3.DGN

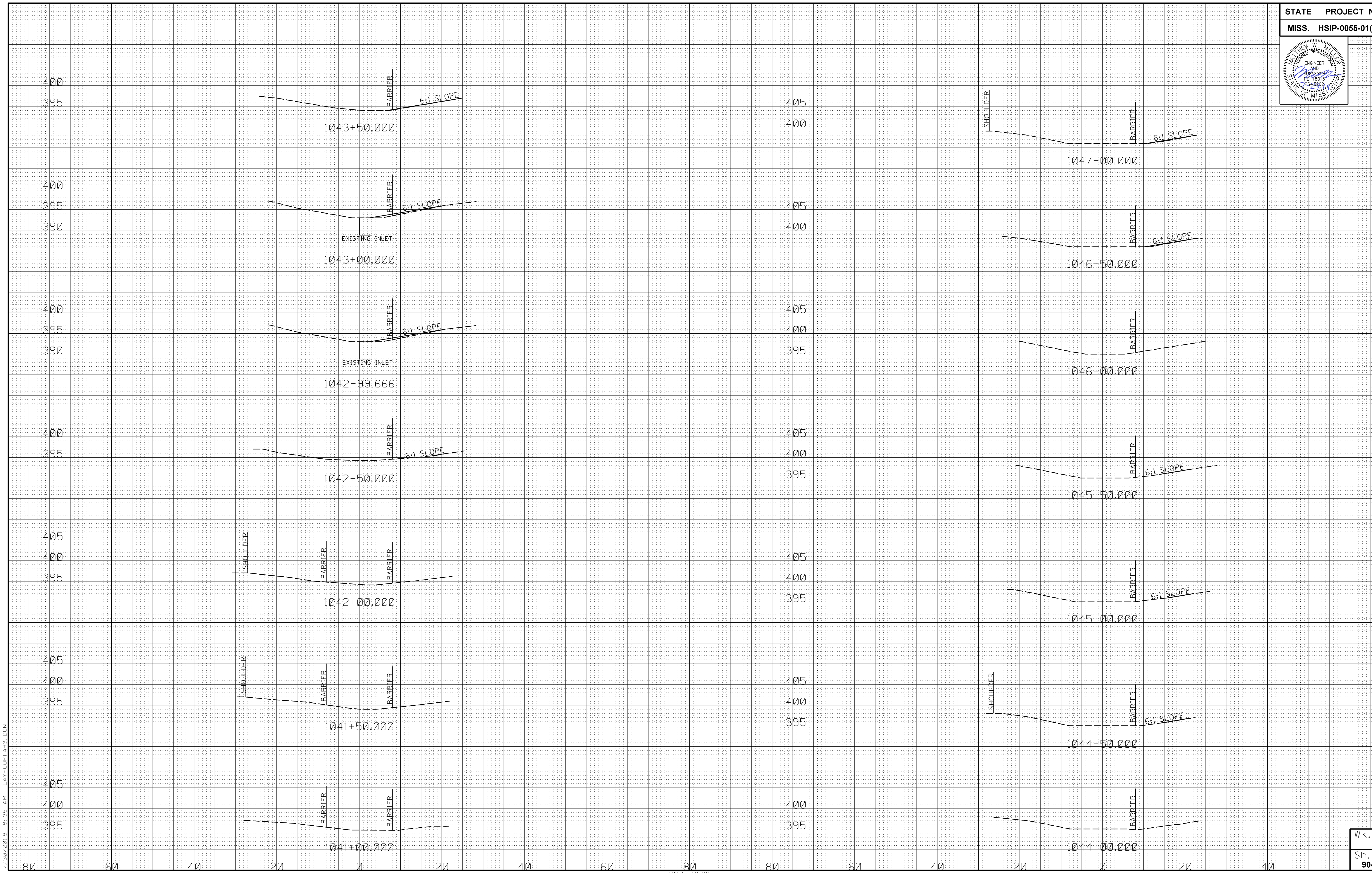
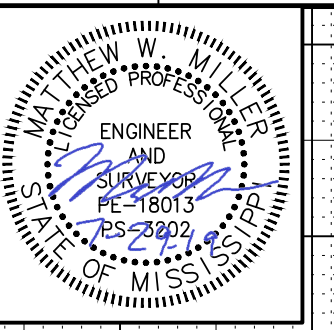

7/30/2019 8:35 AM LAY-COPI-AH3.DGN

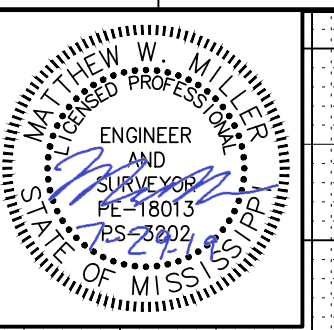

405
400
405
400
405
400
405
400
405
400
405
400
405
400

405
400
405
400
405
400
405
400
405
400
405
400
405
400

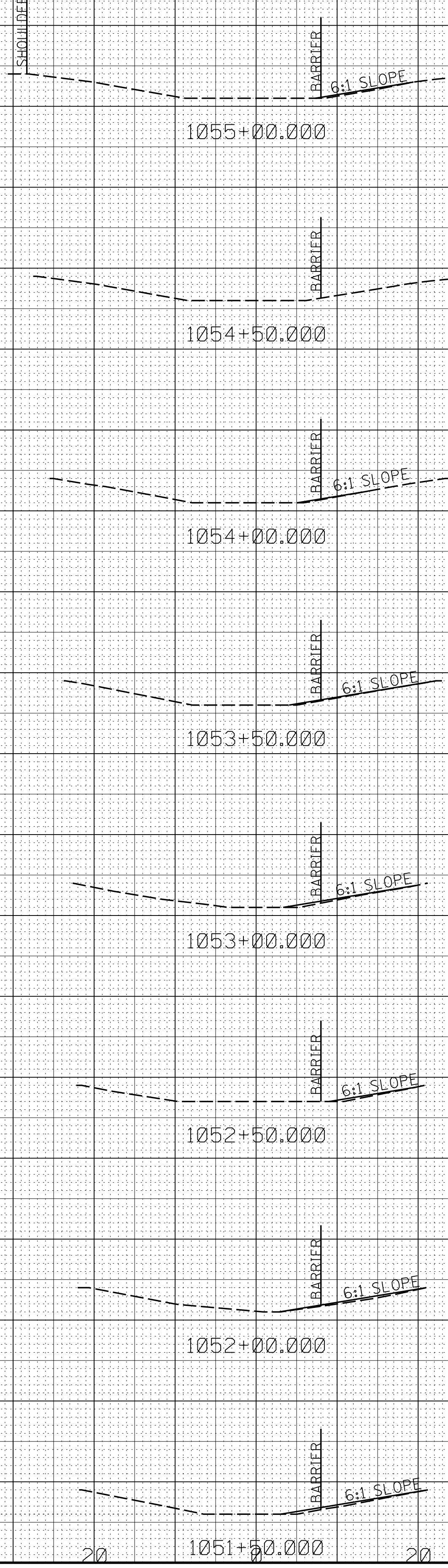
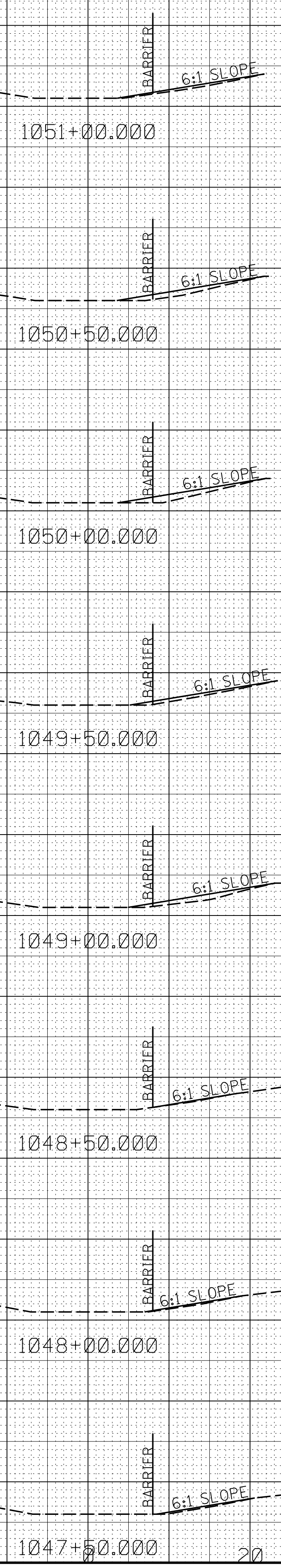

7/26/2019 8:35 AM LAY-COPI-AH3.DGN

80 60 40 20 1047+50.000 20 40 60 80 80 60 40 20 1051+50.000 20 40

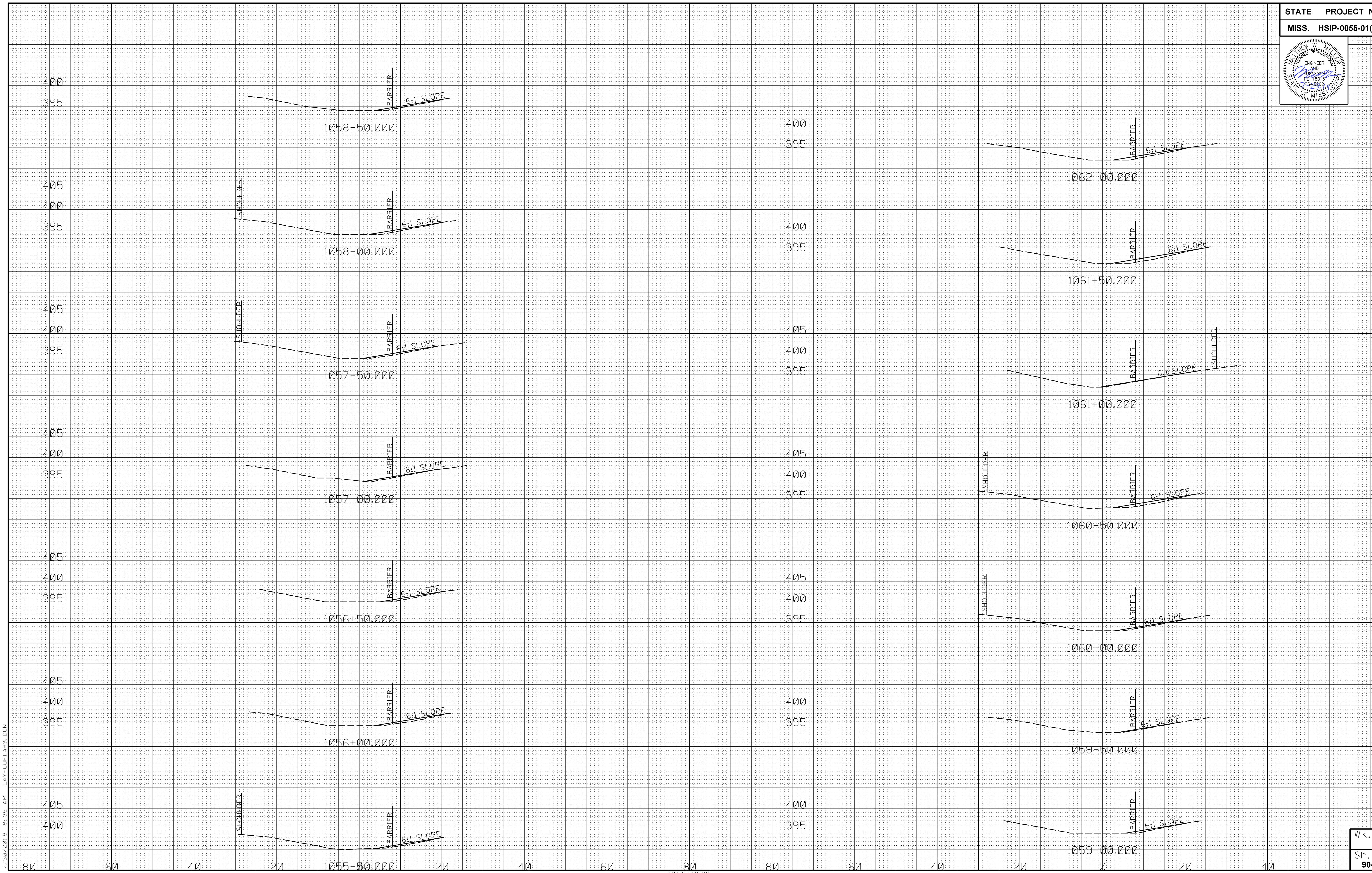
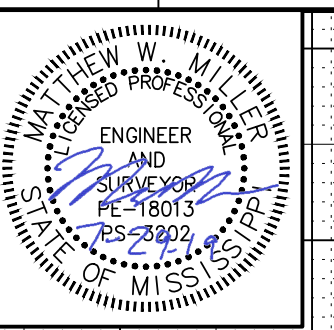

7/30/2019 8:35 AM LAY-COPI-AH3.DGN

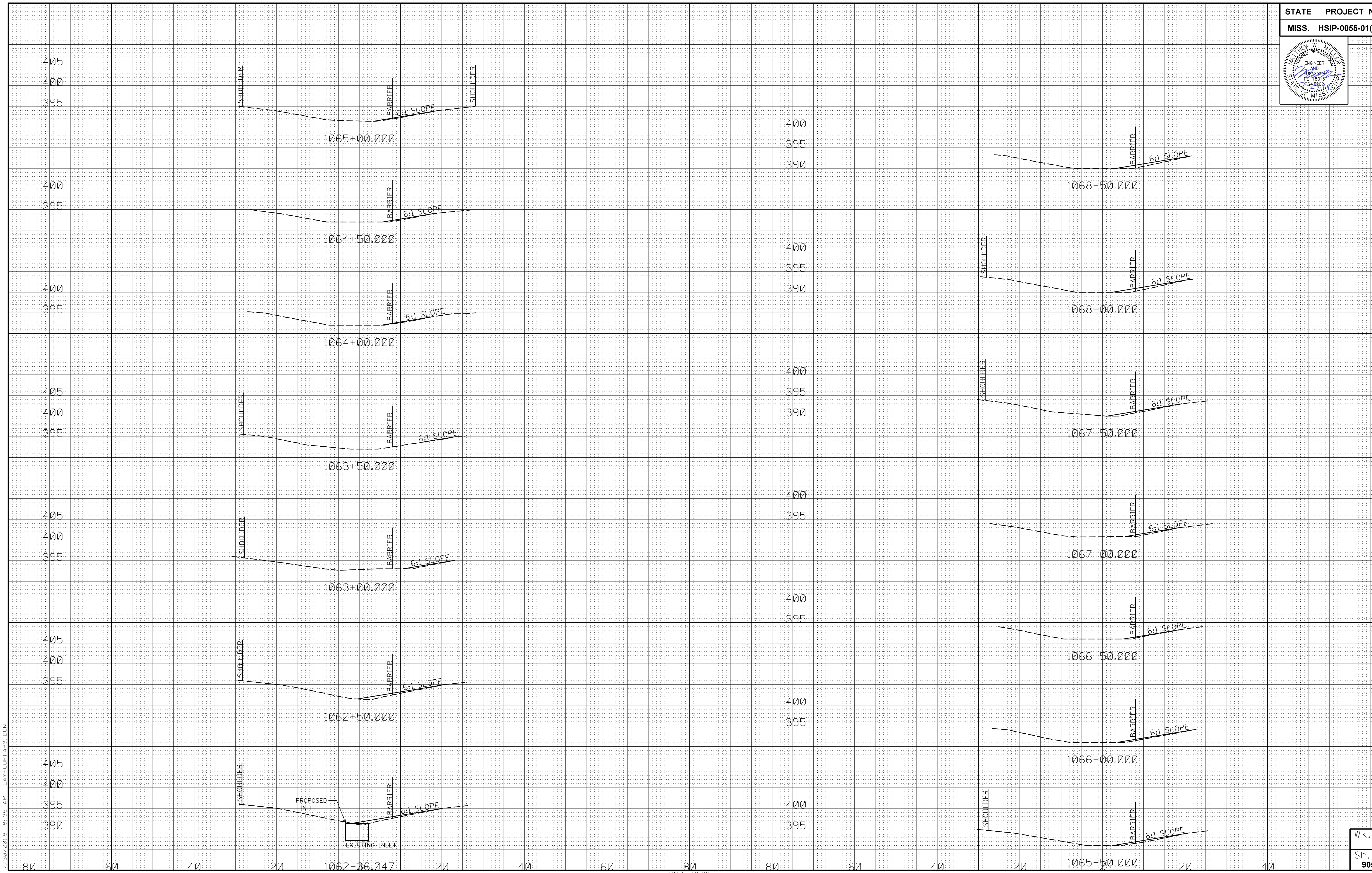
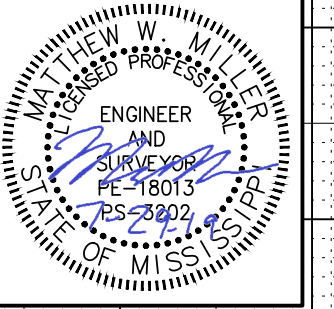

7/30/2019 8:35 AM LAY-COPI-AH3.DGN

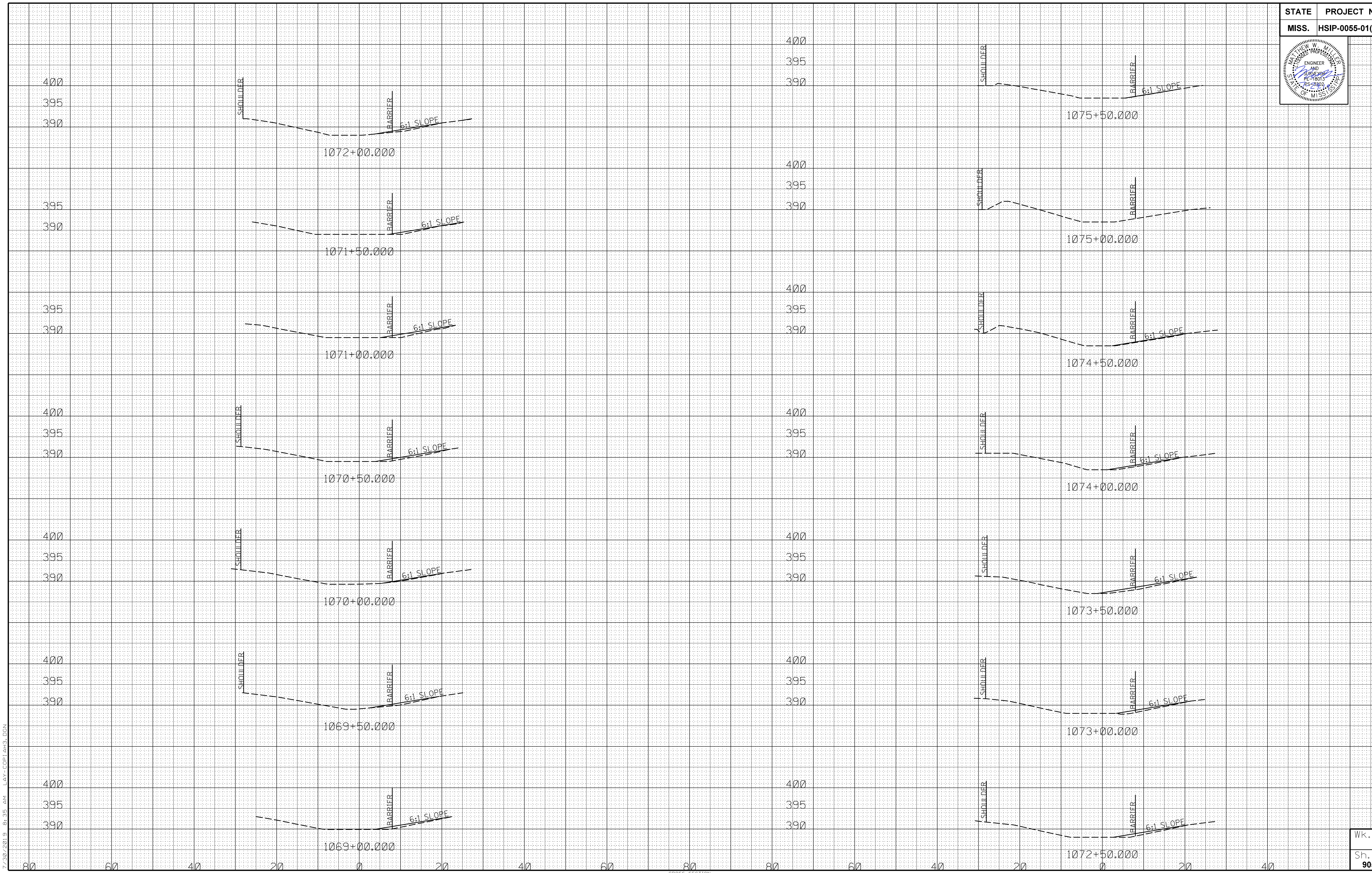
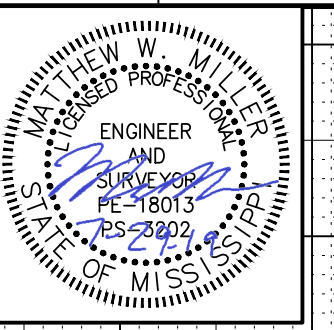

7/30/2019 8:35 AM LAY-COPI-AH3.DGN

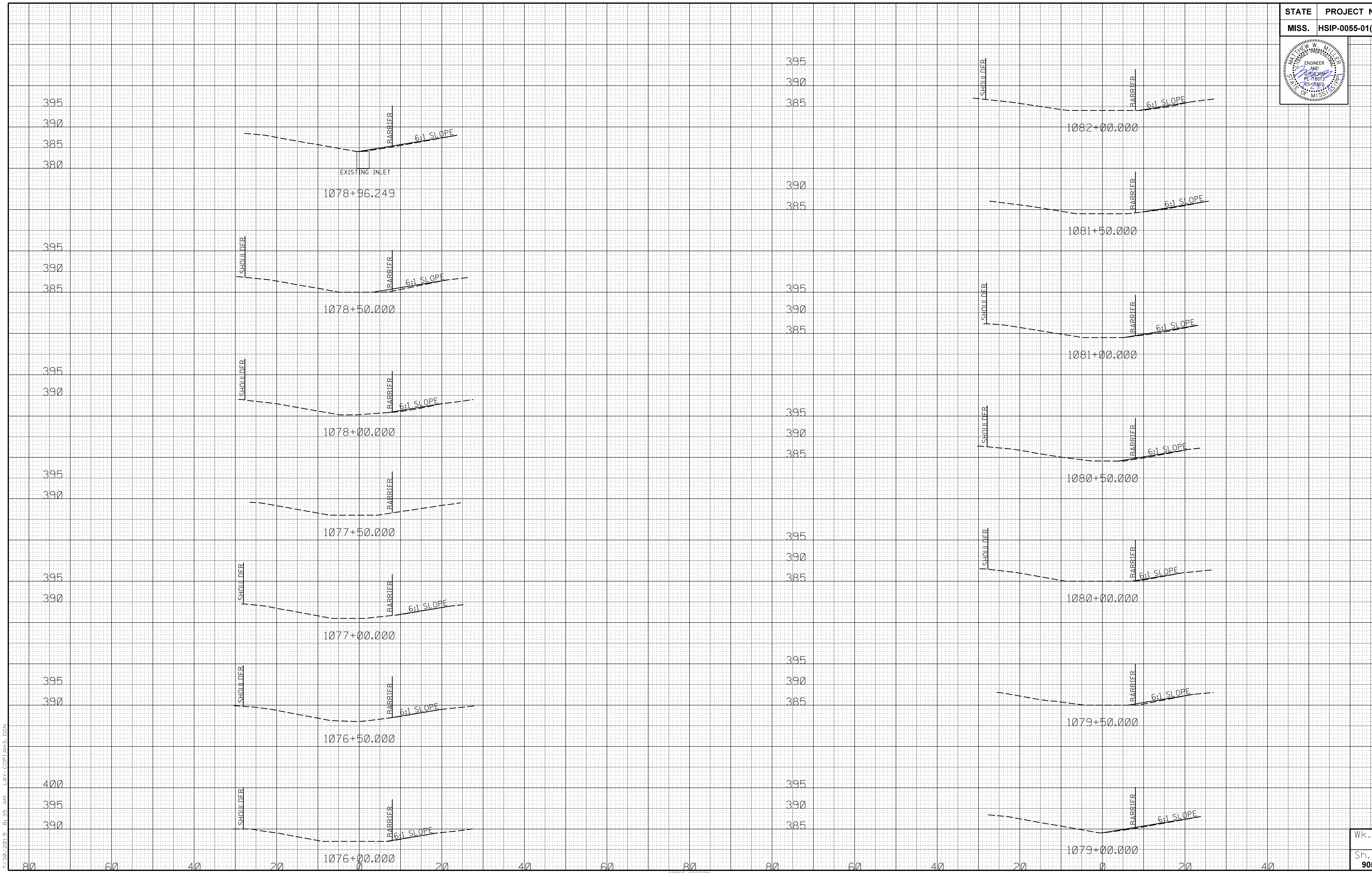
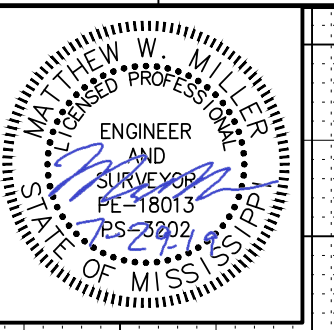

7/30/2019 8:35 AM LAY-COPI-AH3.DGN

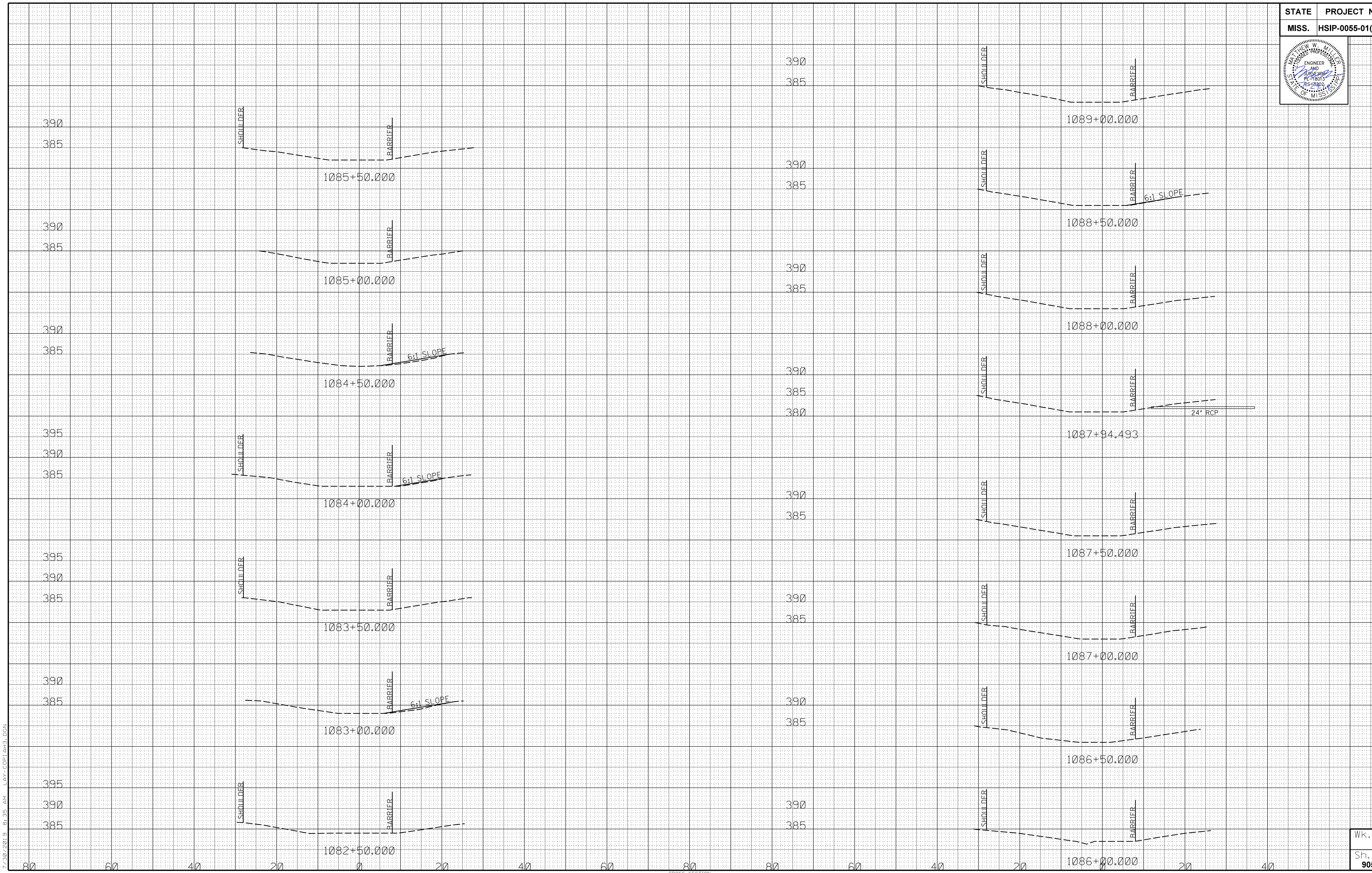
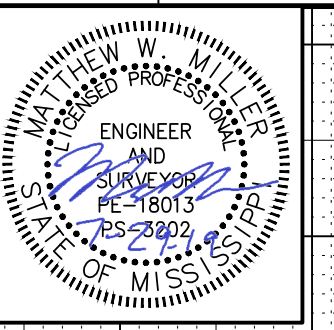

7/30/2019 8:35 AM LAY-COPI-AH3.DGN

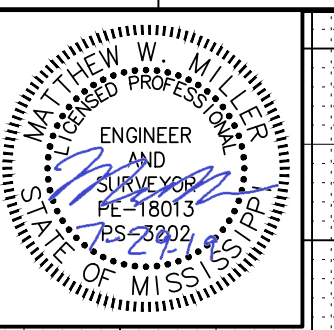

395
390
385

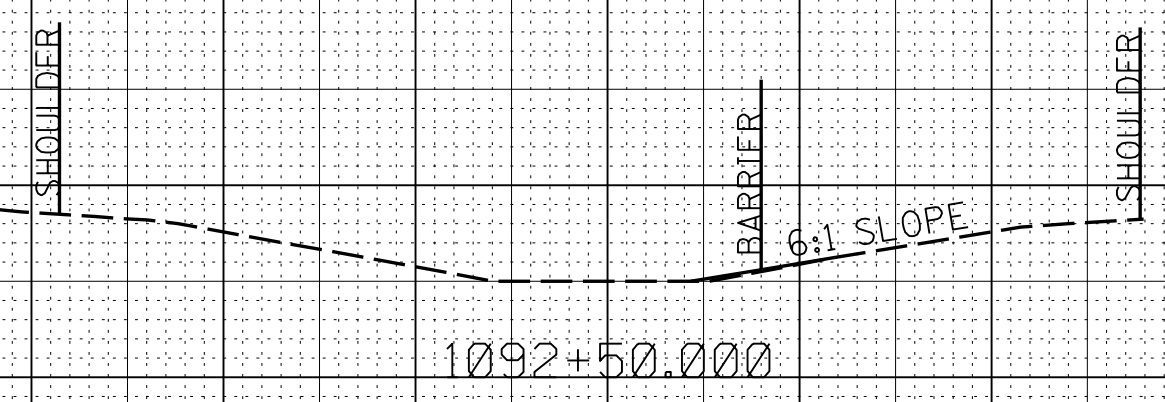

1092+50.000

400
395
390

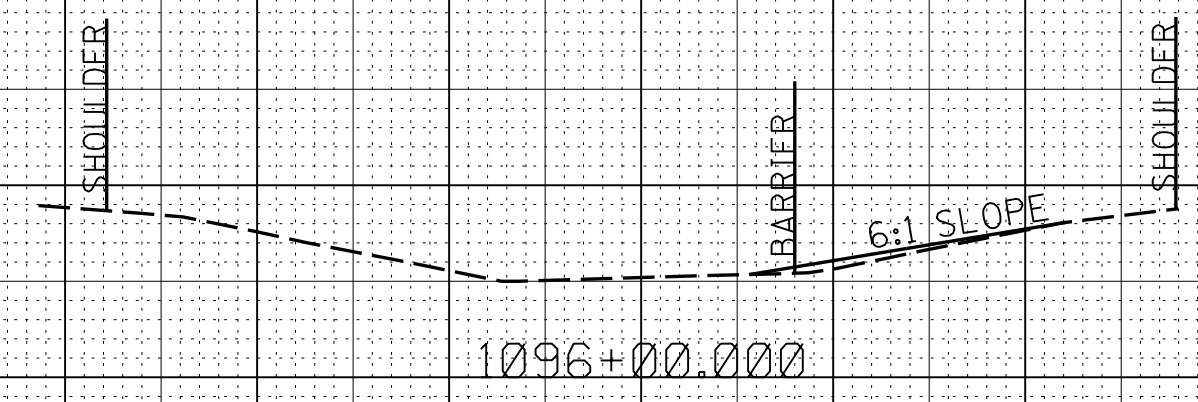

1096+00.000

395
390
385

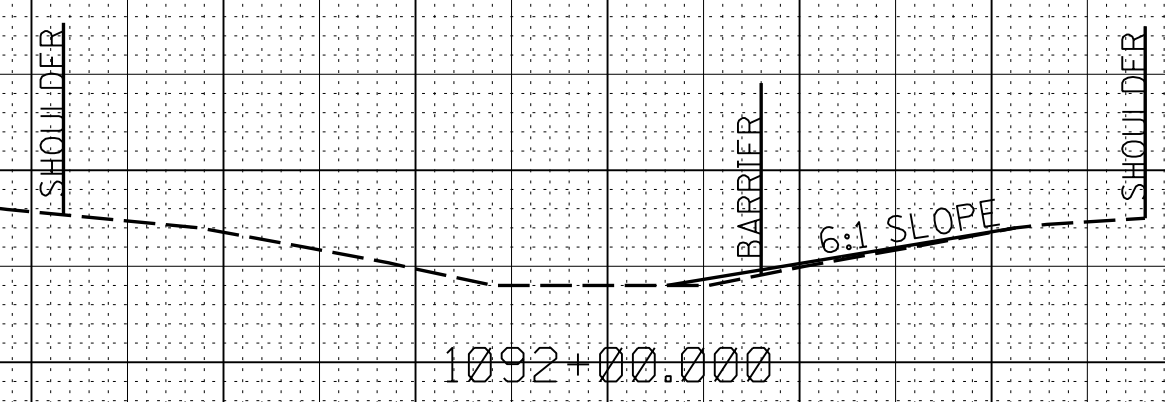

1092+00.000

400
395
390

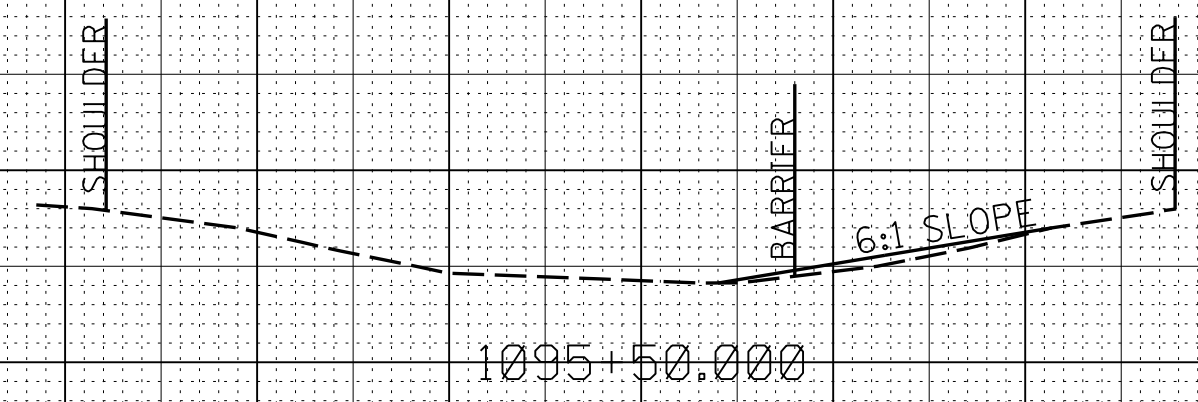

1095+50.000

395
390
385

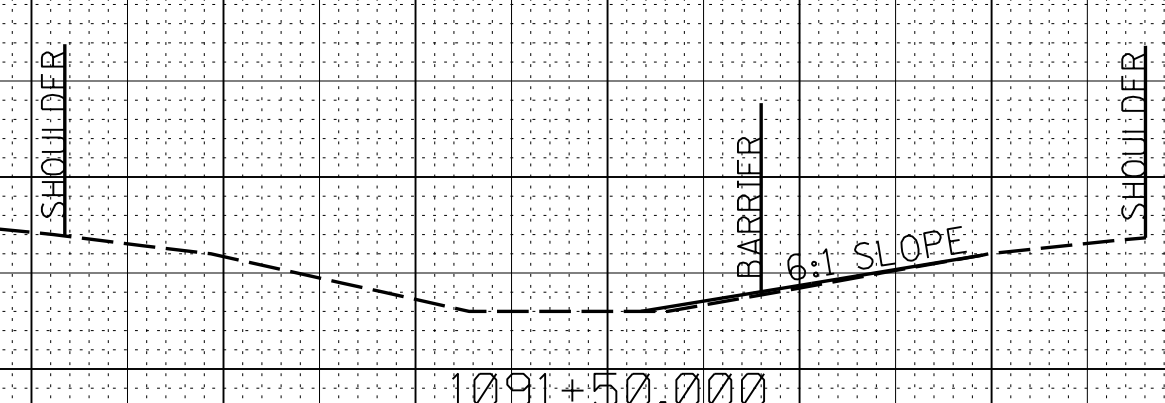

1091+50.000

400
395
390

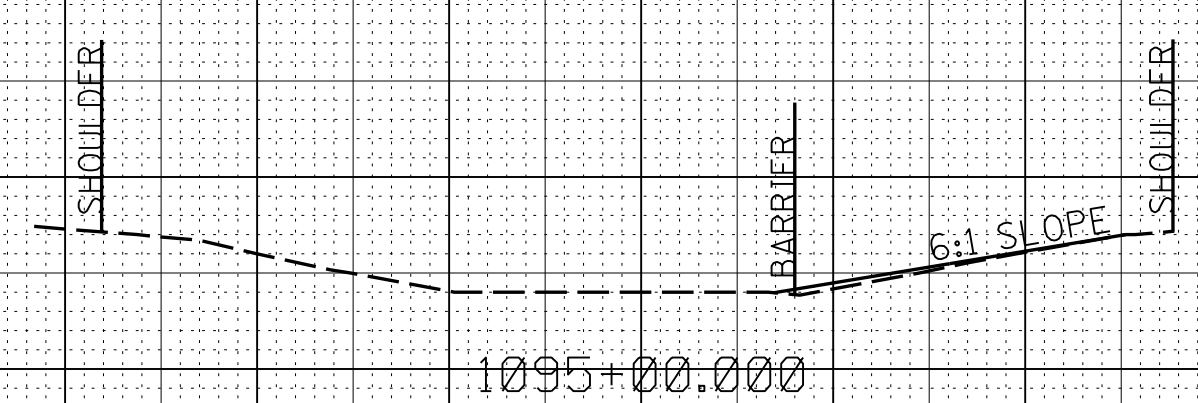

1095+00.000

395
390
385

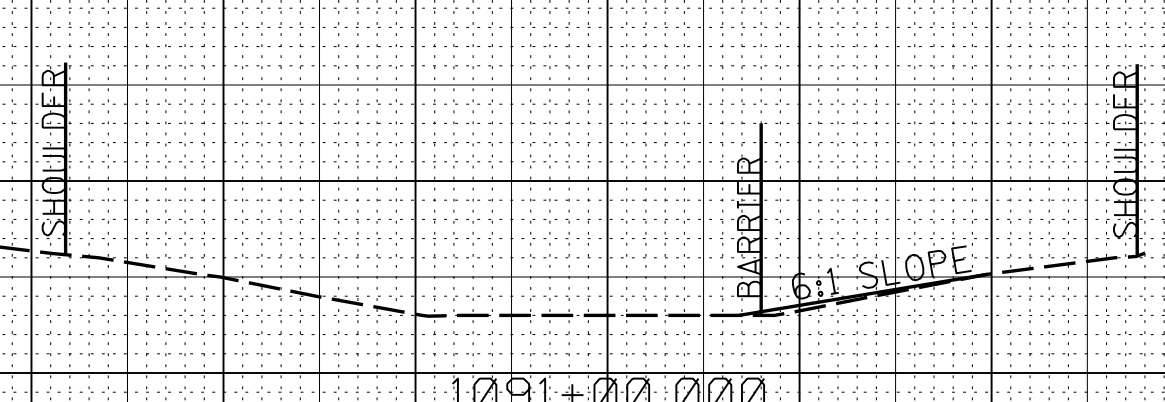

1091+00.000

400
395
390

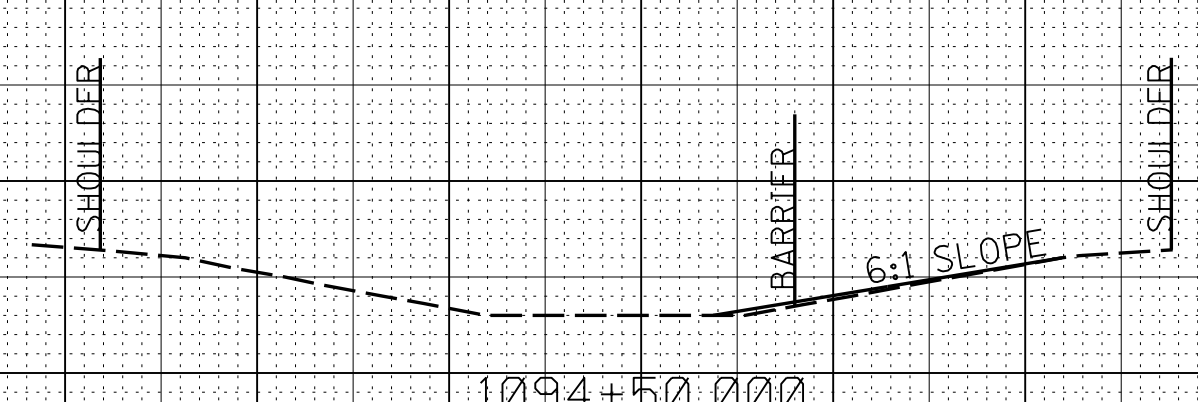

1094+50.000

395
390
385

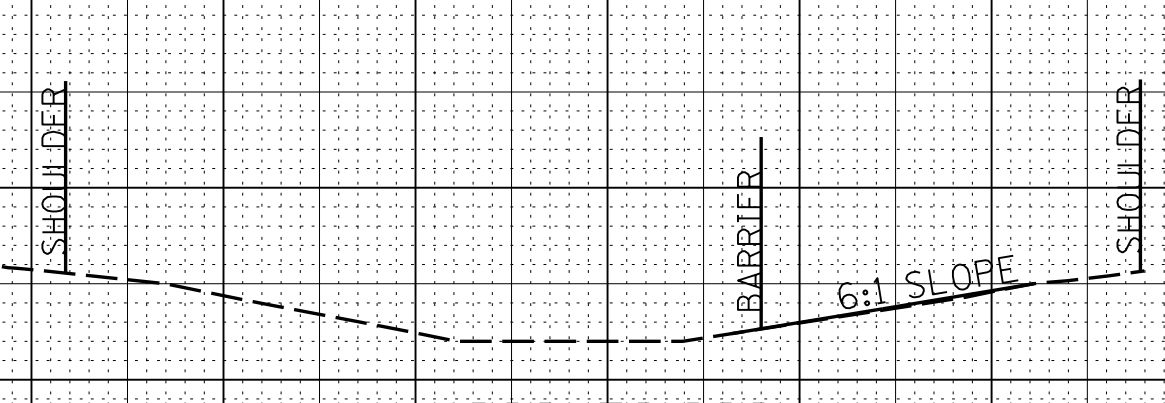

1090+50.000

400
395
390

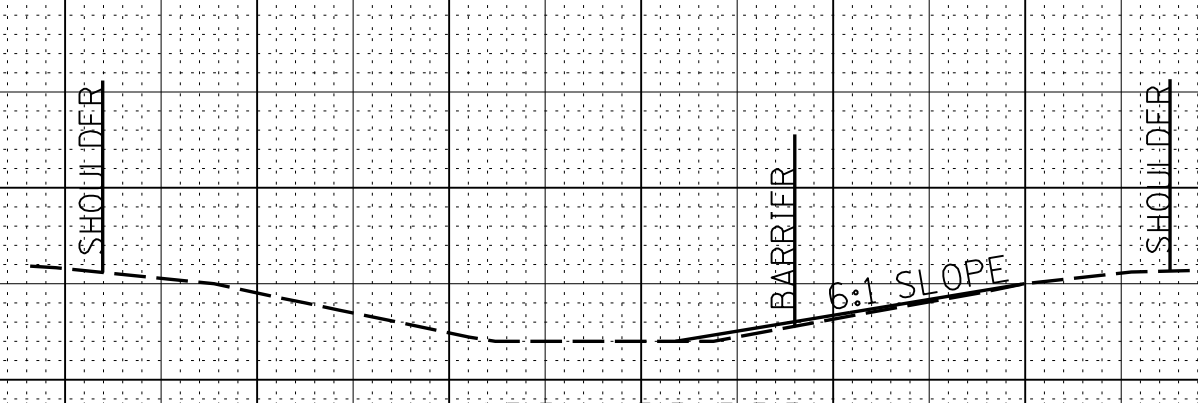

1094+00.000

395
390
385

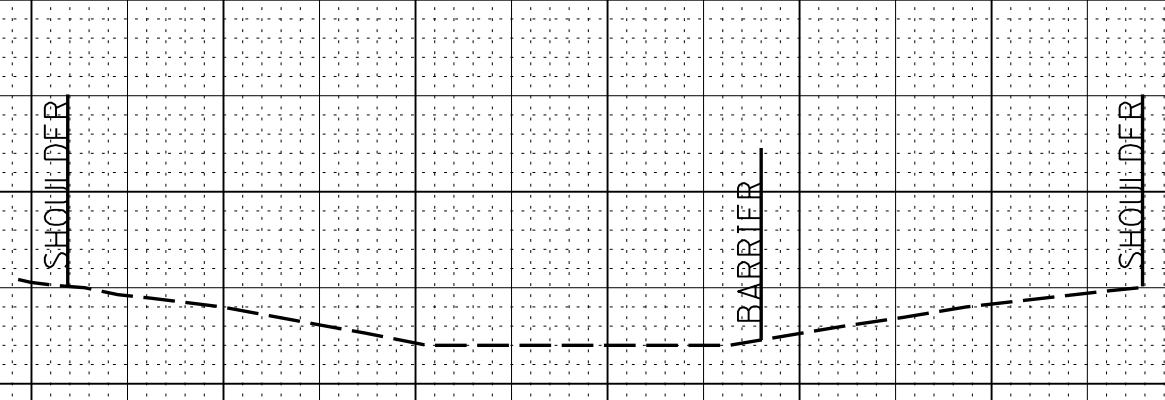

1090+00.000

400
395
390

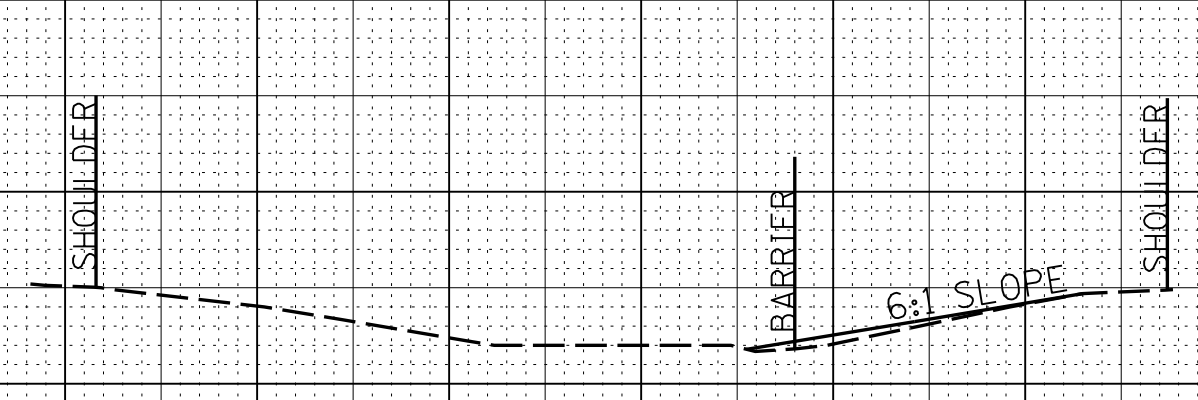

1093+50.000

390
385

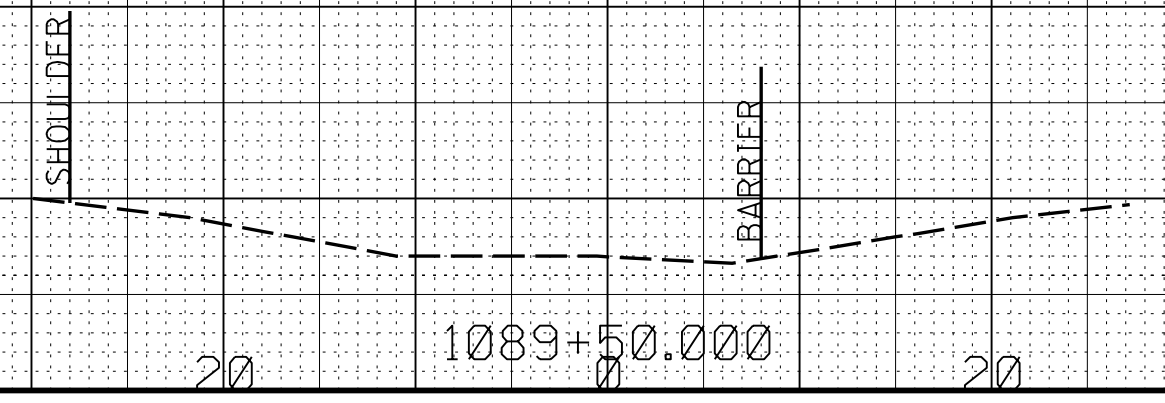

1089+50.000

395
390

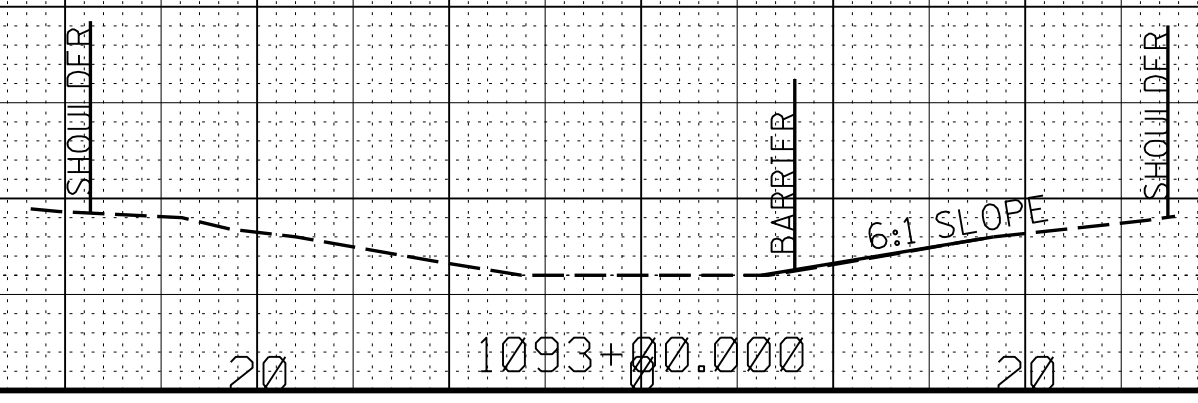

1093+00.000

7/30/2019 8:35 AM LAY-COPI-AH3.DGN

80 60 40 20 0 20 40 60 80 80 60 40 20 0 20 40 60 80 80 60 40 20 40

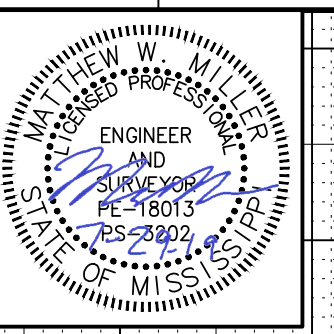

7/30/2019 8:35 AM LAY-COPI-AH3.DGN

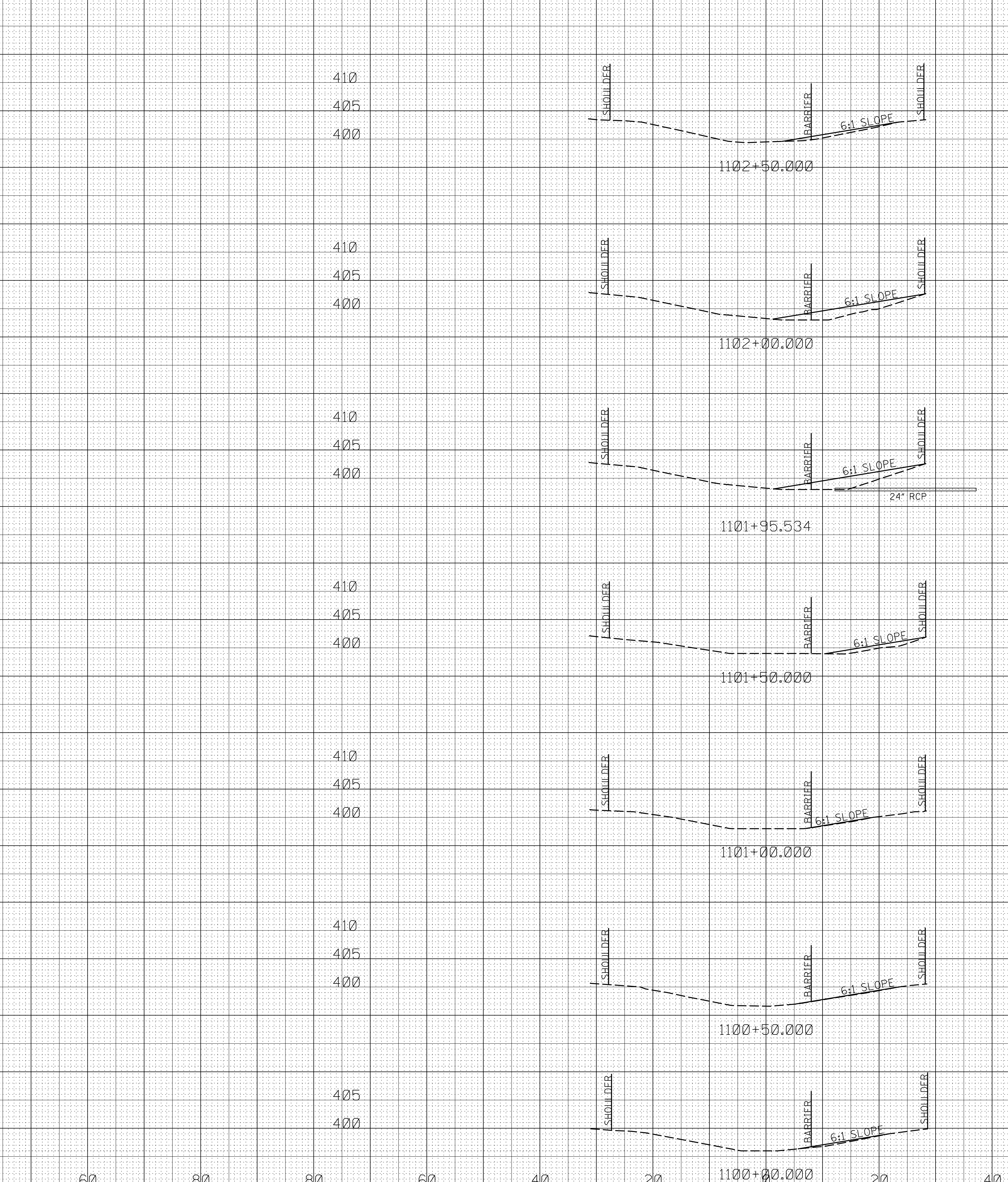
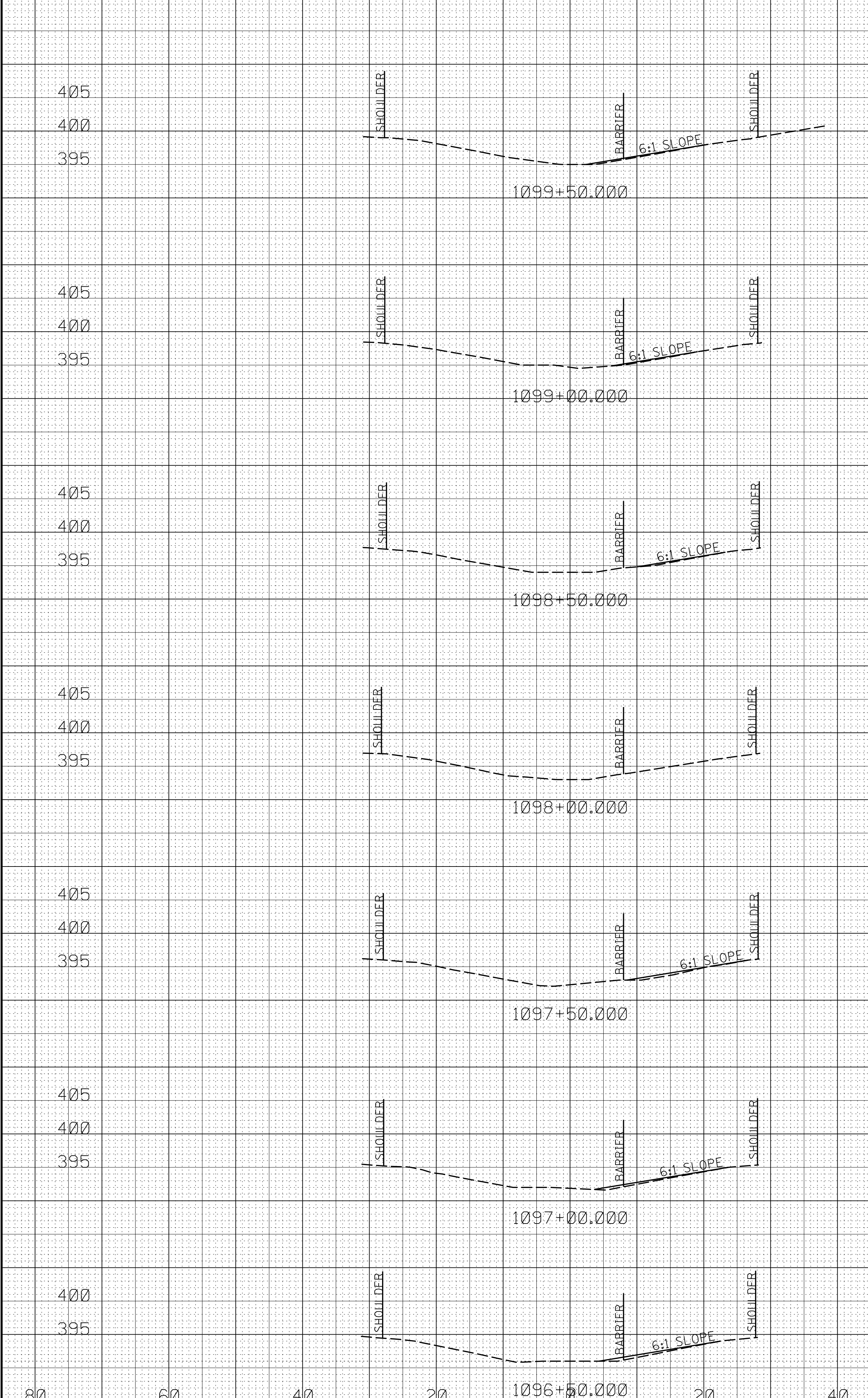

80 60 40 20 1096+50.000 20 40 60 80

80 60 40 20 1100+00.000 20 40

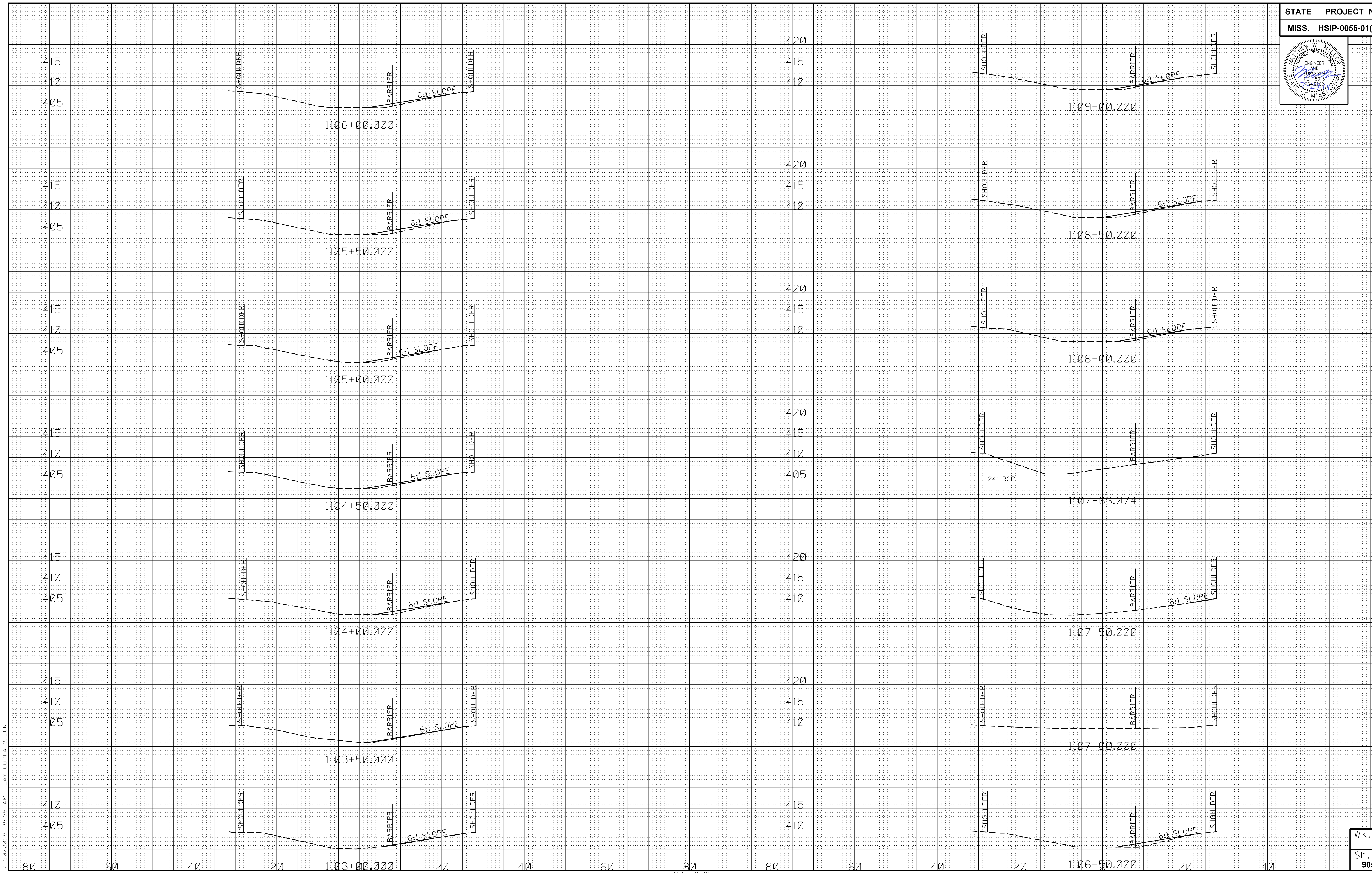
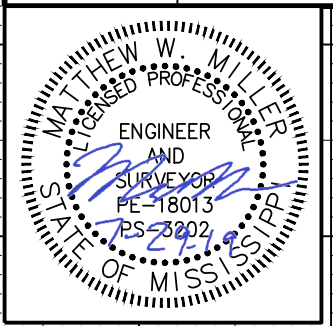

7/30/2019 8:35 AM LAY-COPI-AH3.DGN

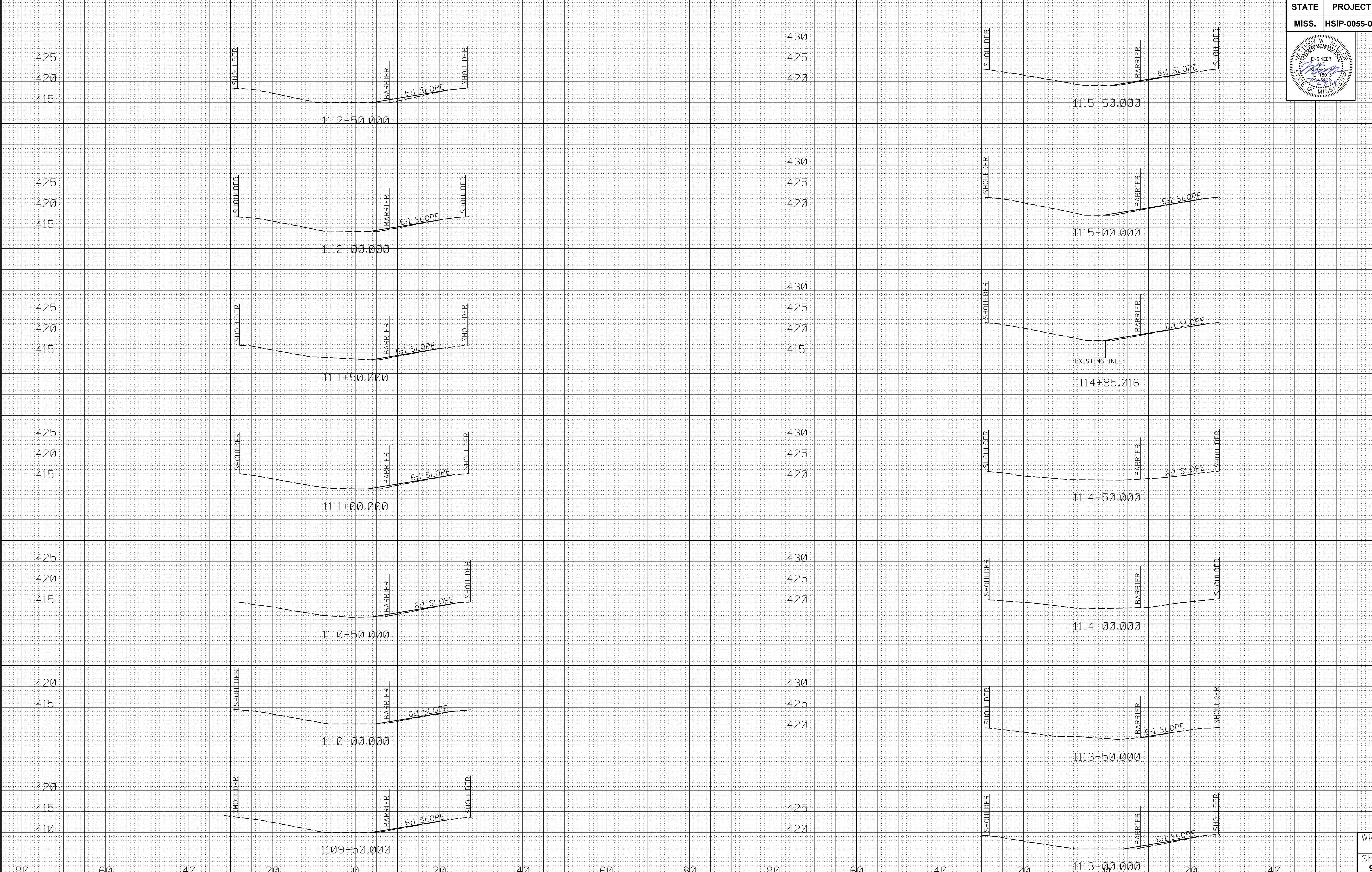
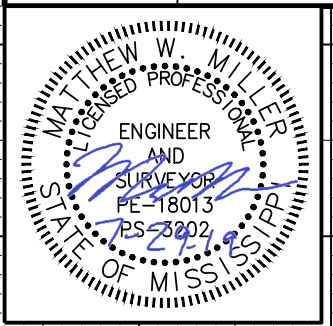

7/30/2019 8:35 AM LAY-COPI-AH3.DGN

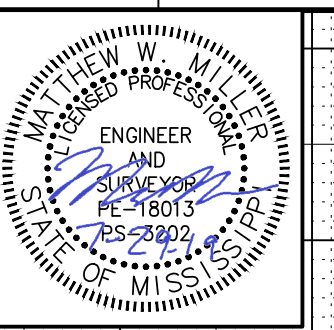

435
430
435
430
435
430
425
435
430
425
435
430
425
430
425
420

440
435
440
435
430
440
435
430
440
435
430
440
435
430
440
435
430

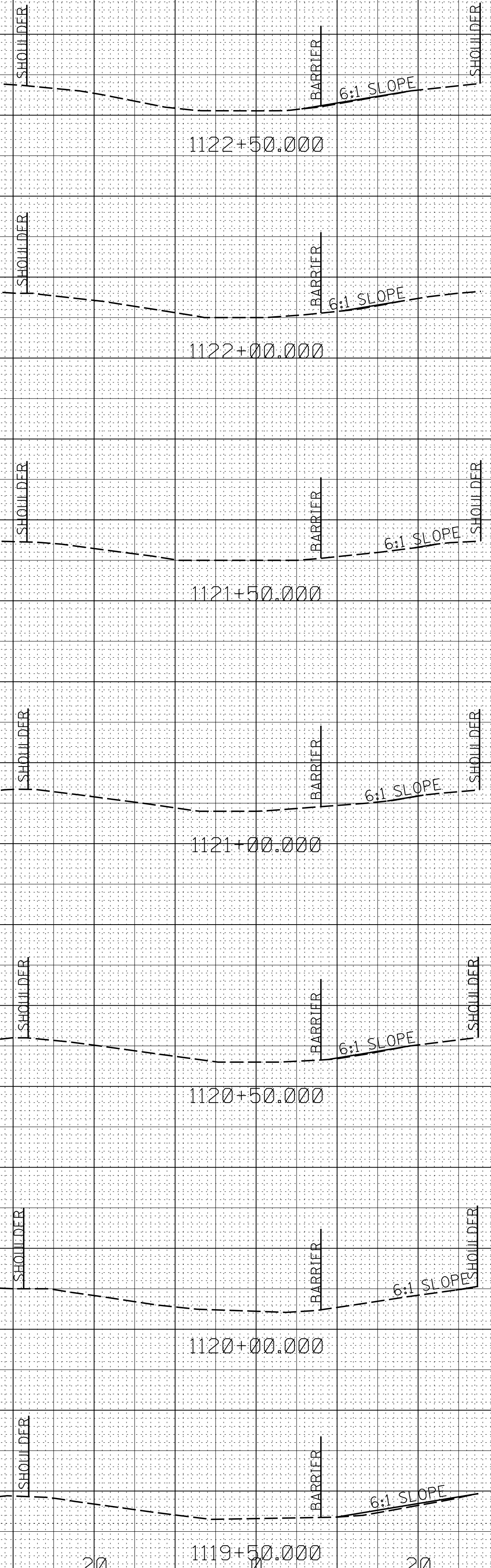
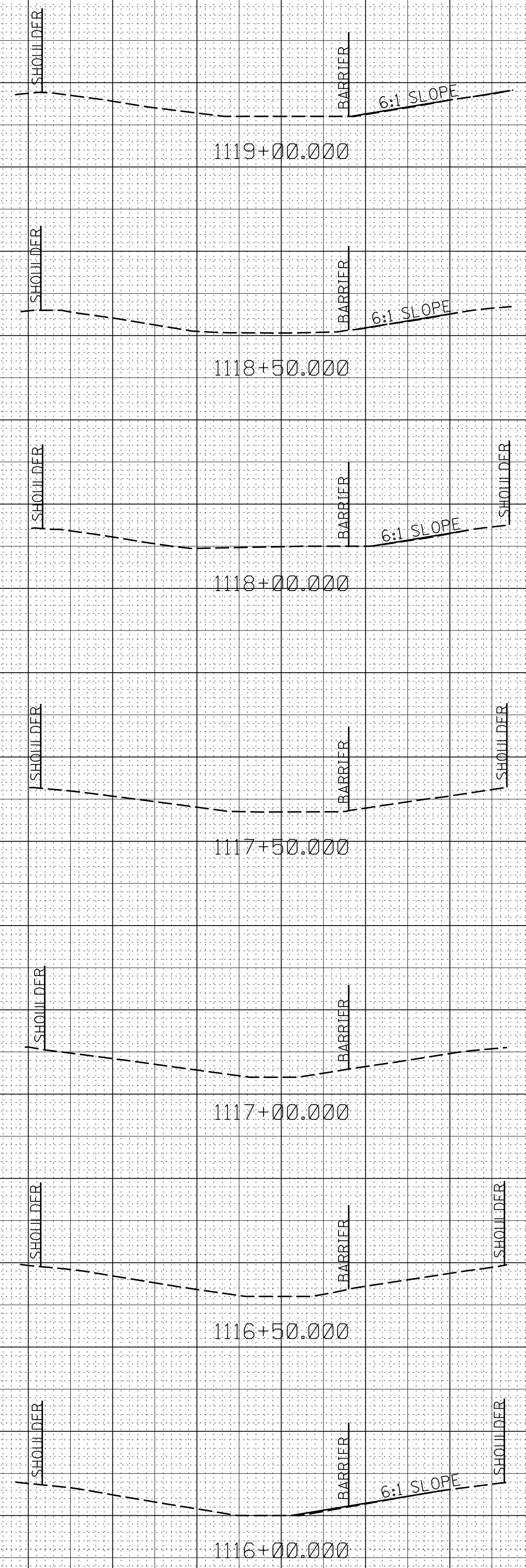

7/30/2019 8:35 AM LAY-COPI-AH3.DGN

80 60 40 20 0 20 40 60 80 80 60 40 20 0 20 40

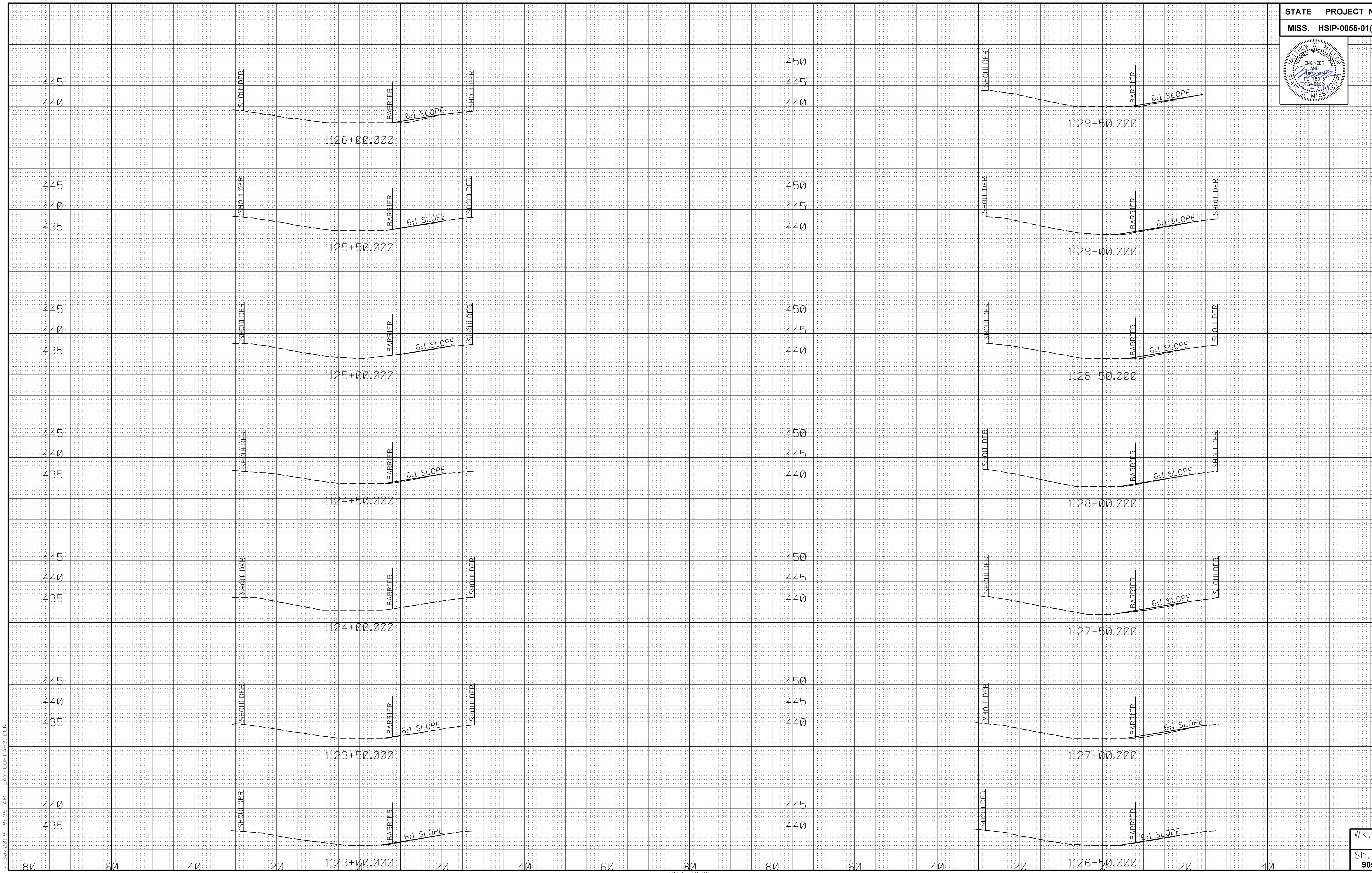
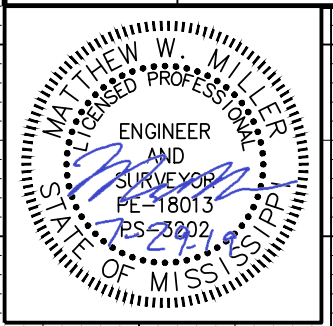

7/26/2019 8:35 AM LAY-COPI-AH3.DGN

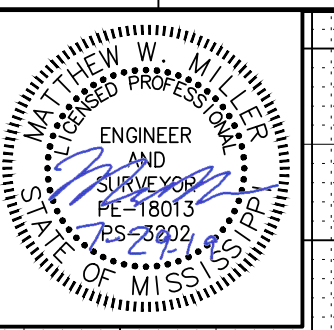

450
445

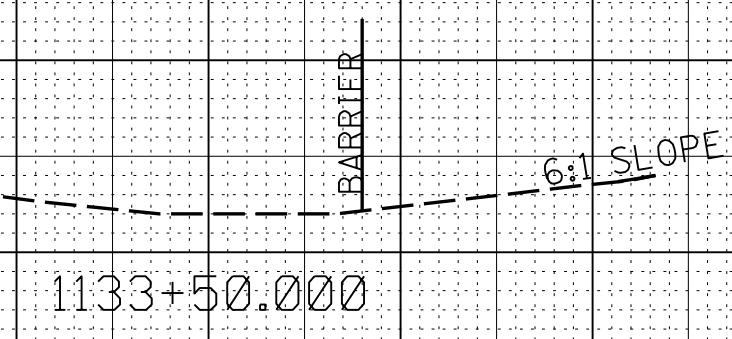

450
445

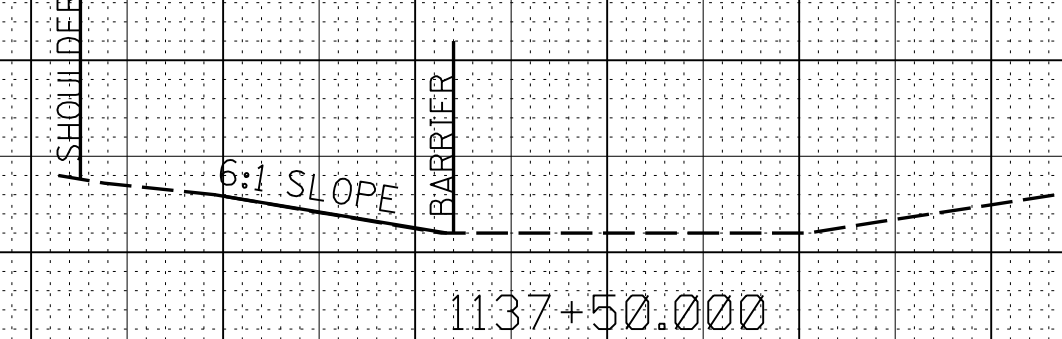

450
445

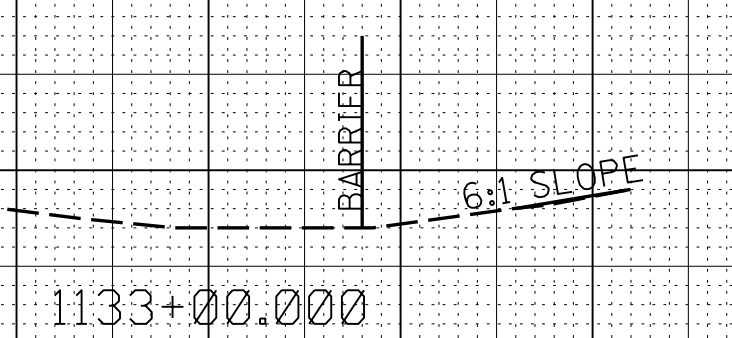

450
445

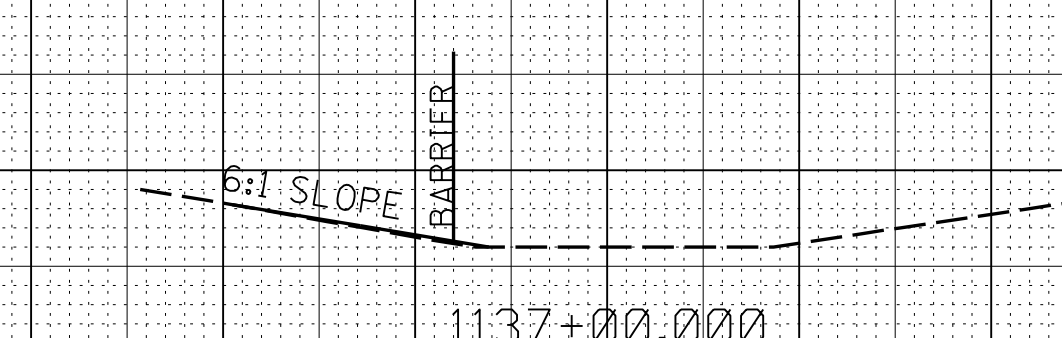

450
445

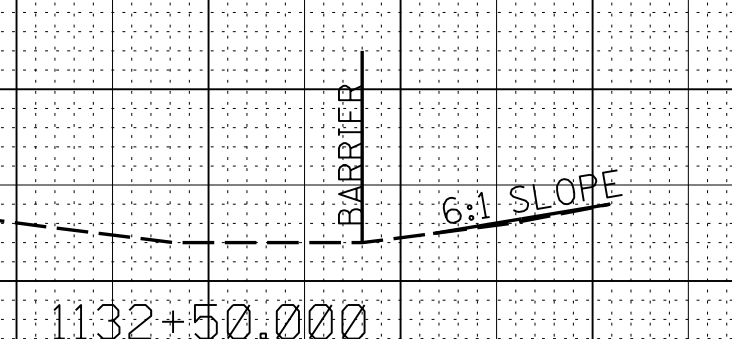

450
445

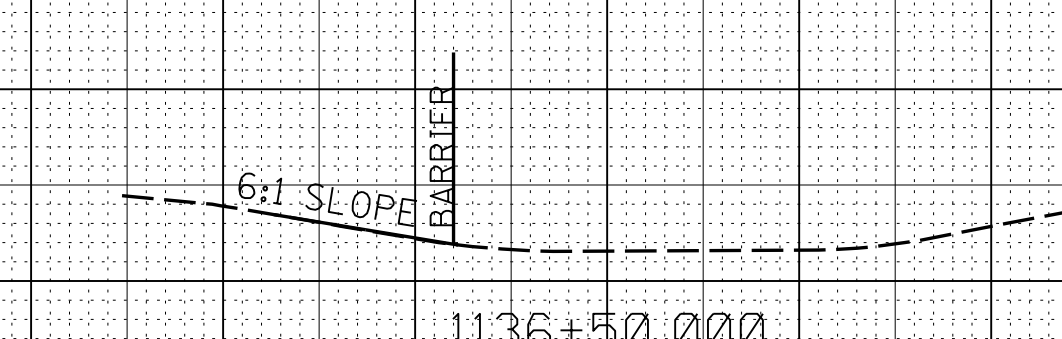

450
445



450
445

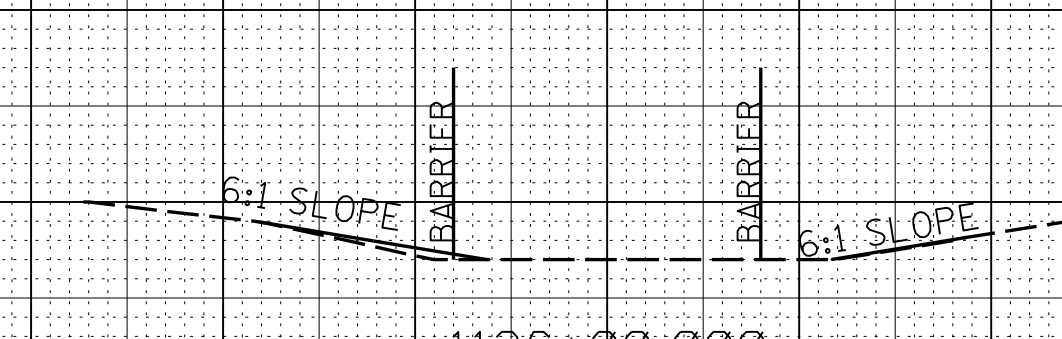

450
445



450
445



450
445

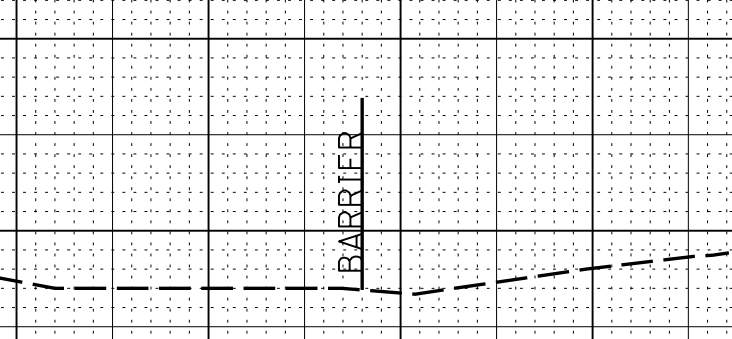

450
445

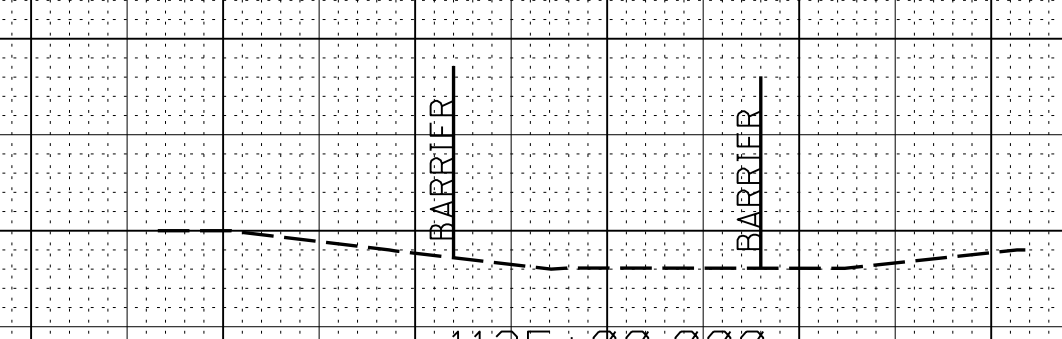

450
445

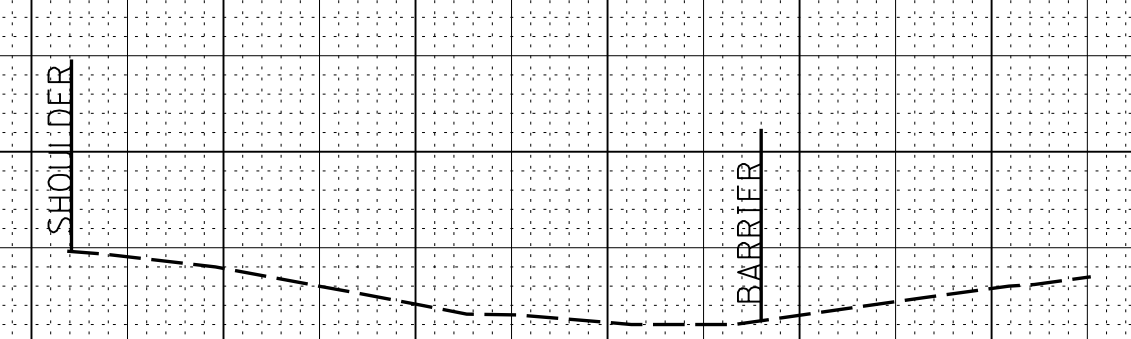

450
445

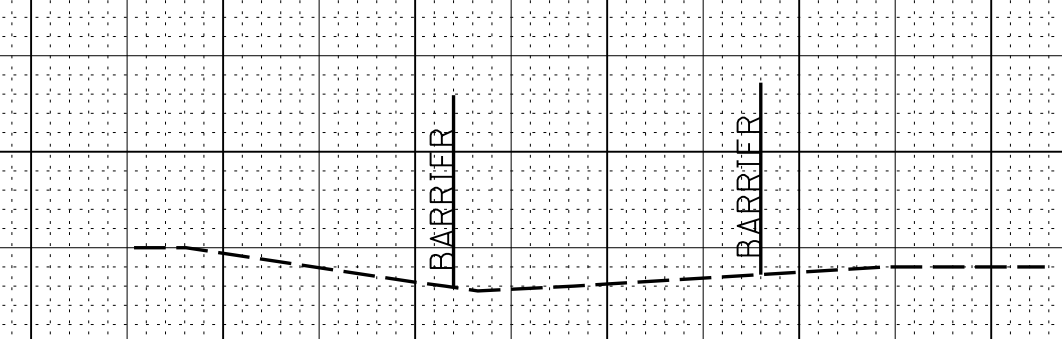

450
445

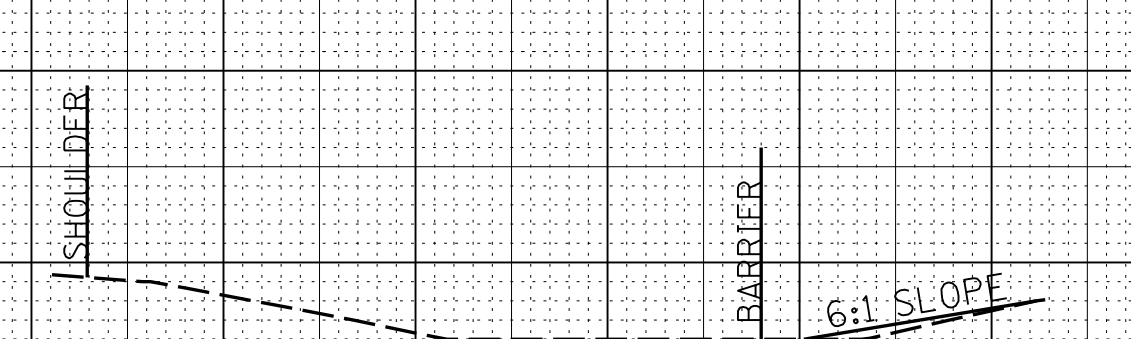

450
445

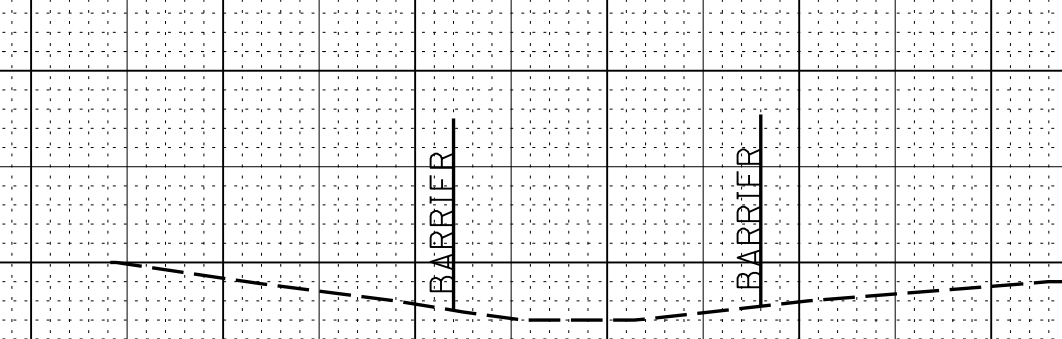

7/30/2019 8:35 AM LAY-COPI-AH3.DGN

80 60 40 20 1130+00.000 20 40 60 80 80 60 40 20 1134+00.000 20 40

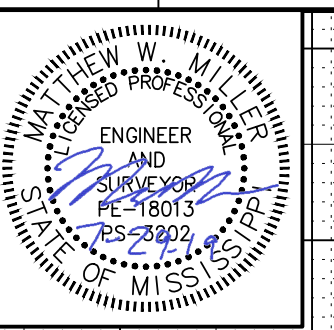

450
445
440
450
445
440
450
445
440
450
445
440
450
445
440
450
445
440
450
445
440

445
440
435
430
445
440
435
445
440
435
445
440
435
445
440
435
445
440
435
445
440
435

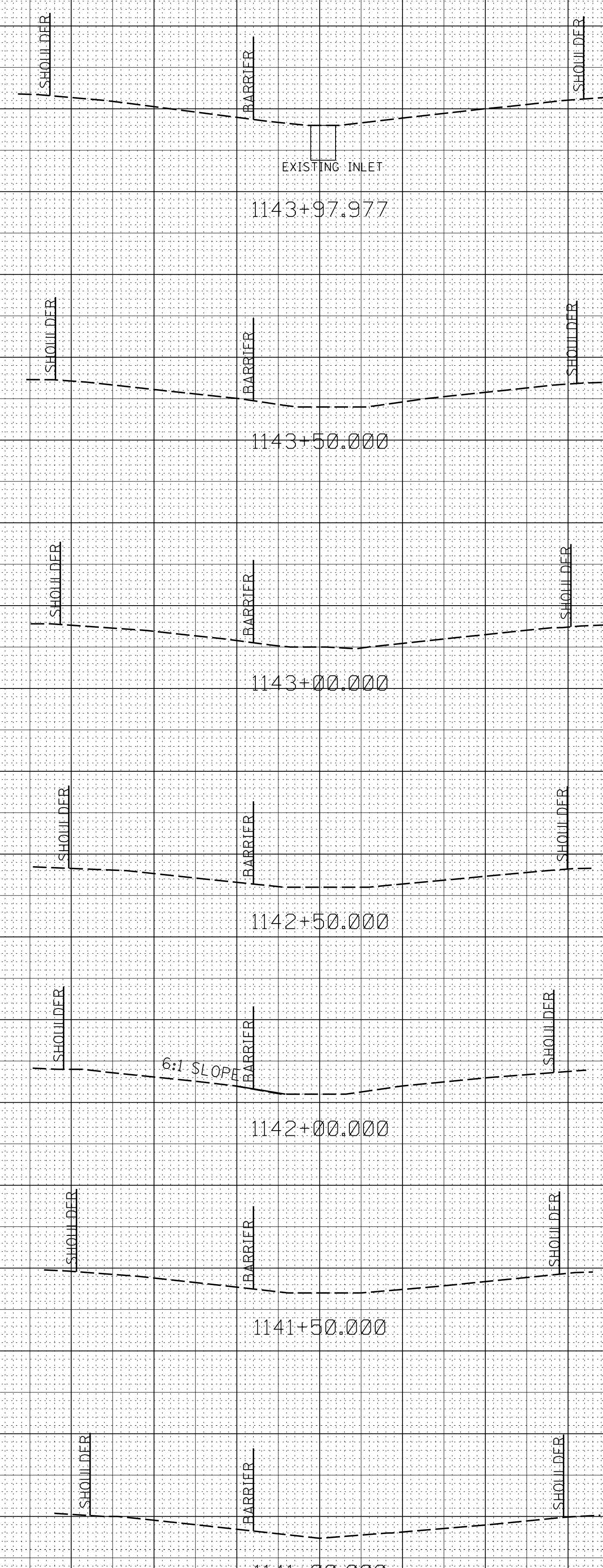
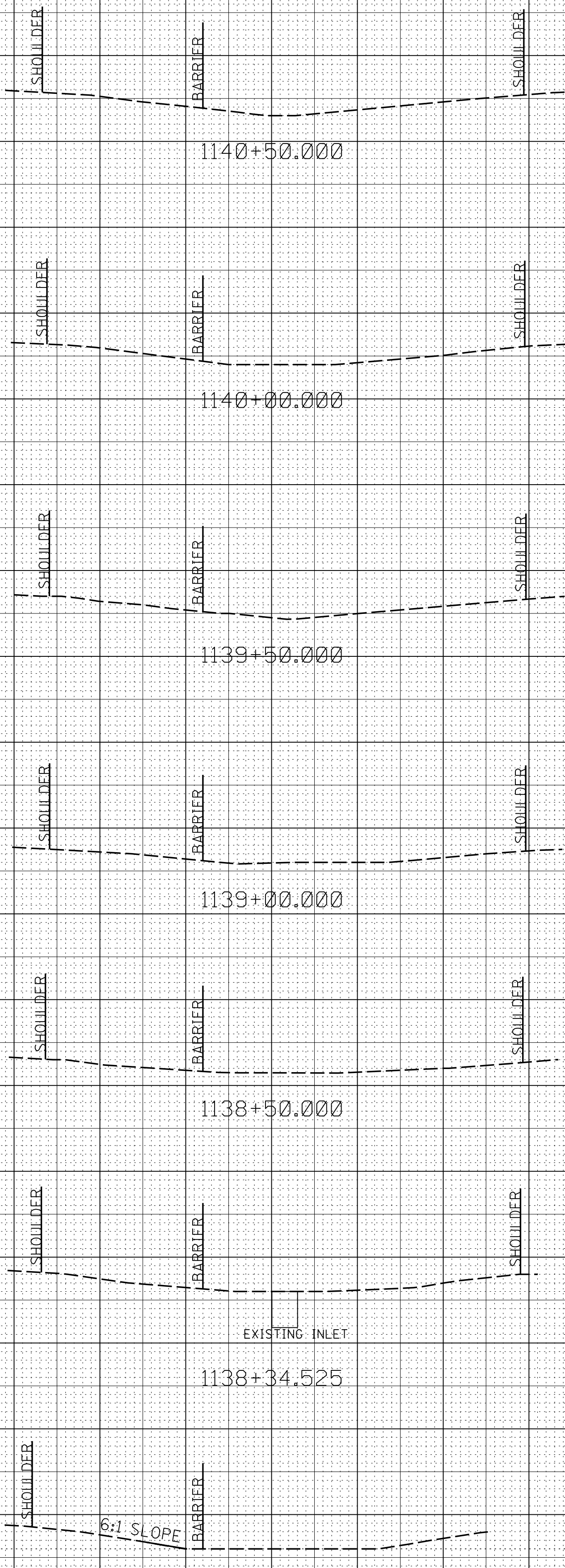

7/30/2019 8:35 AM LAY-COPI-AH3.DGN

80 60 40 20 0 20 40 60 80 80 60 40 20 0 20 40

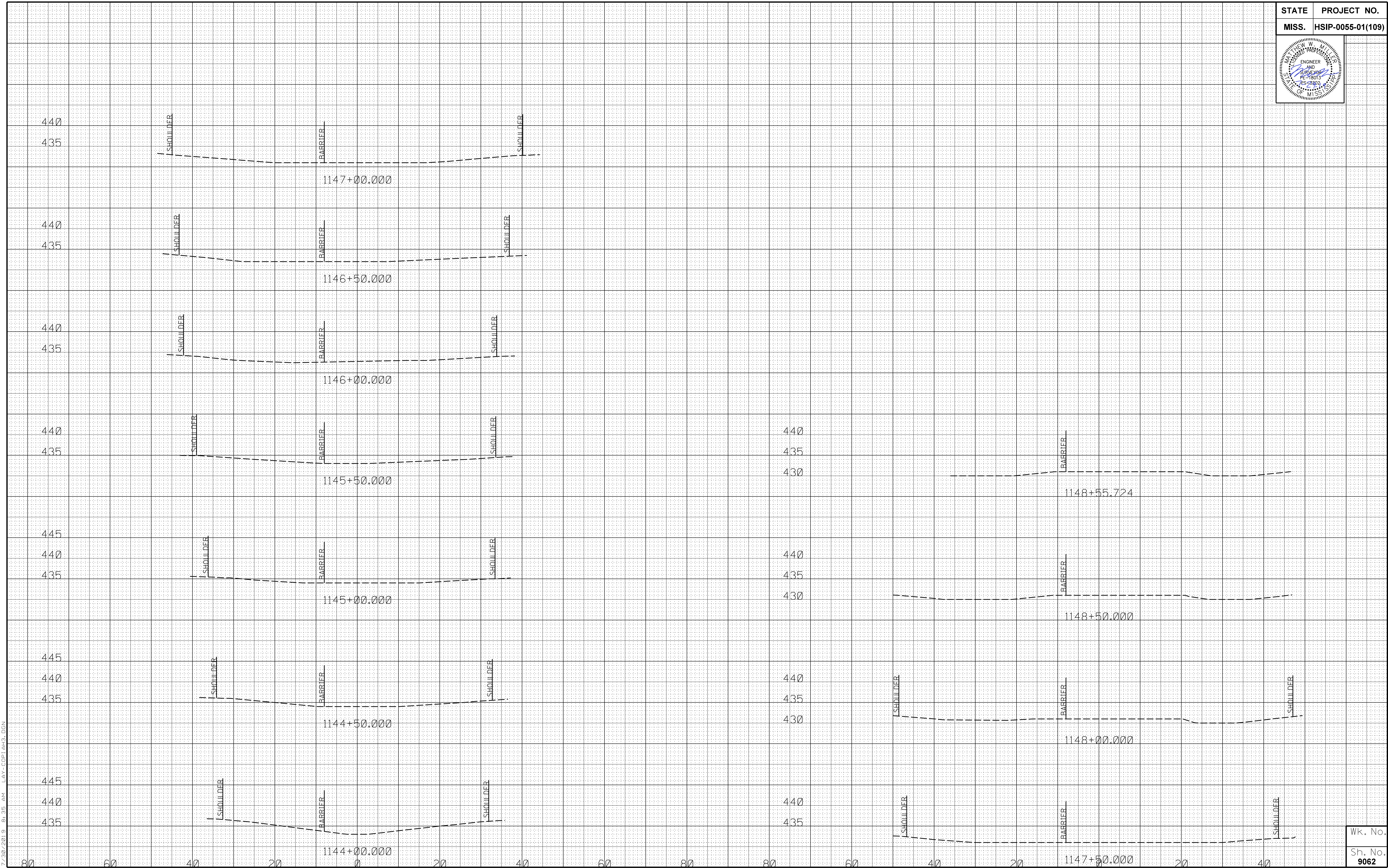
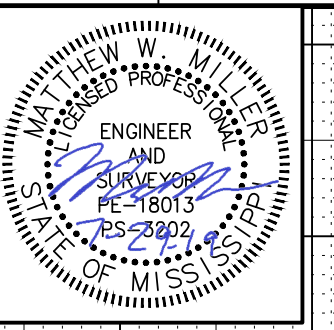

7/30/2019 8:35 AM LAY-COPI-AH3.DGN

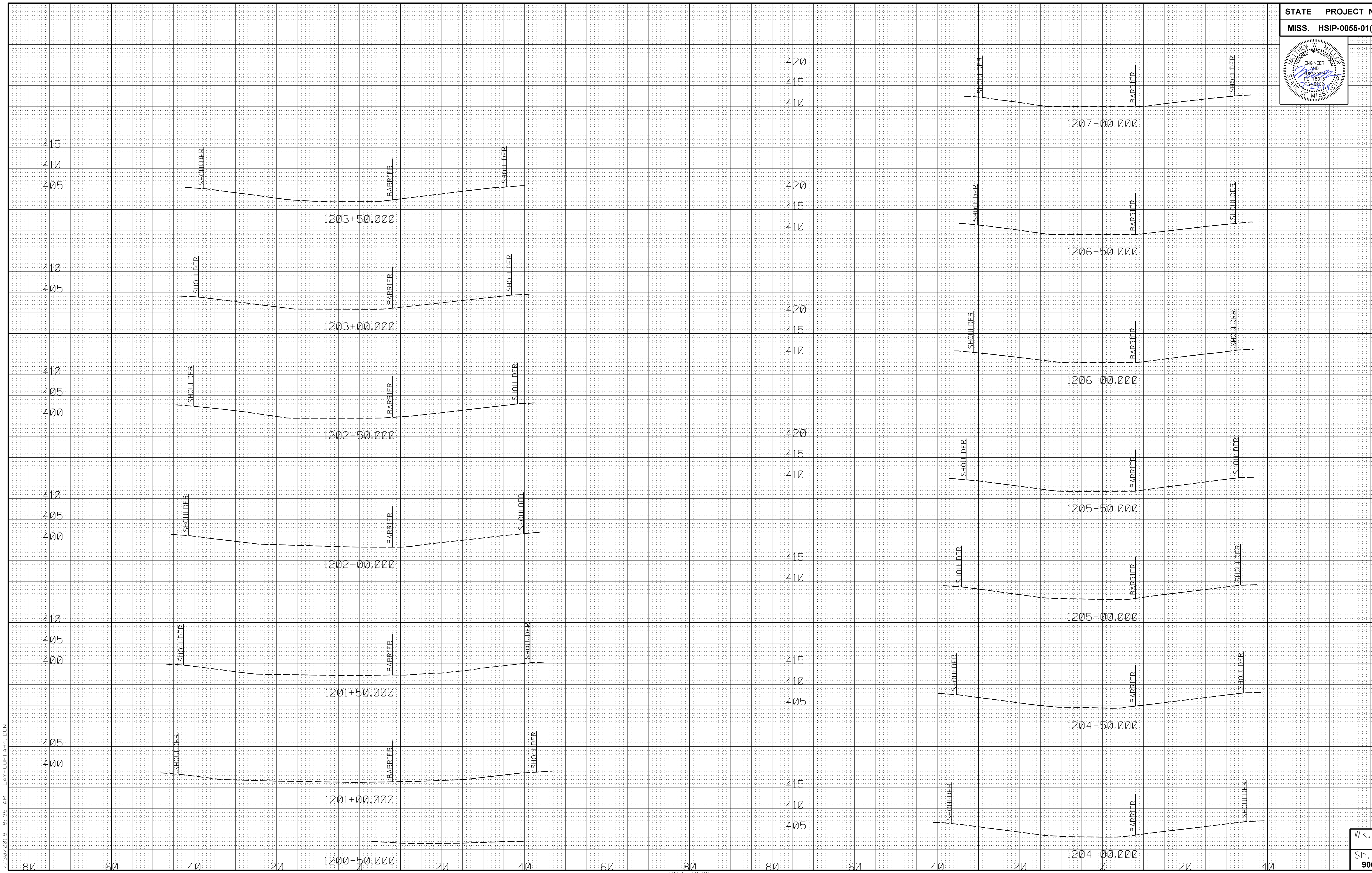
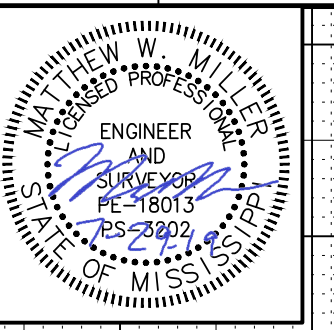

7/30/2019 8:35 AM LAY-COPIA4.DGN

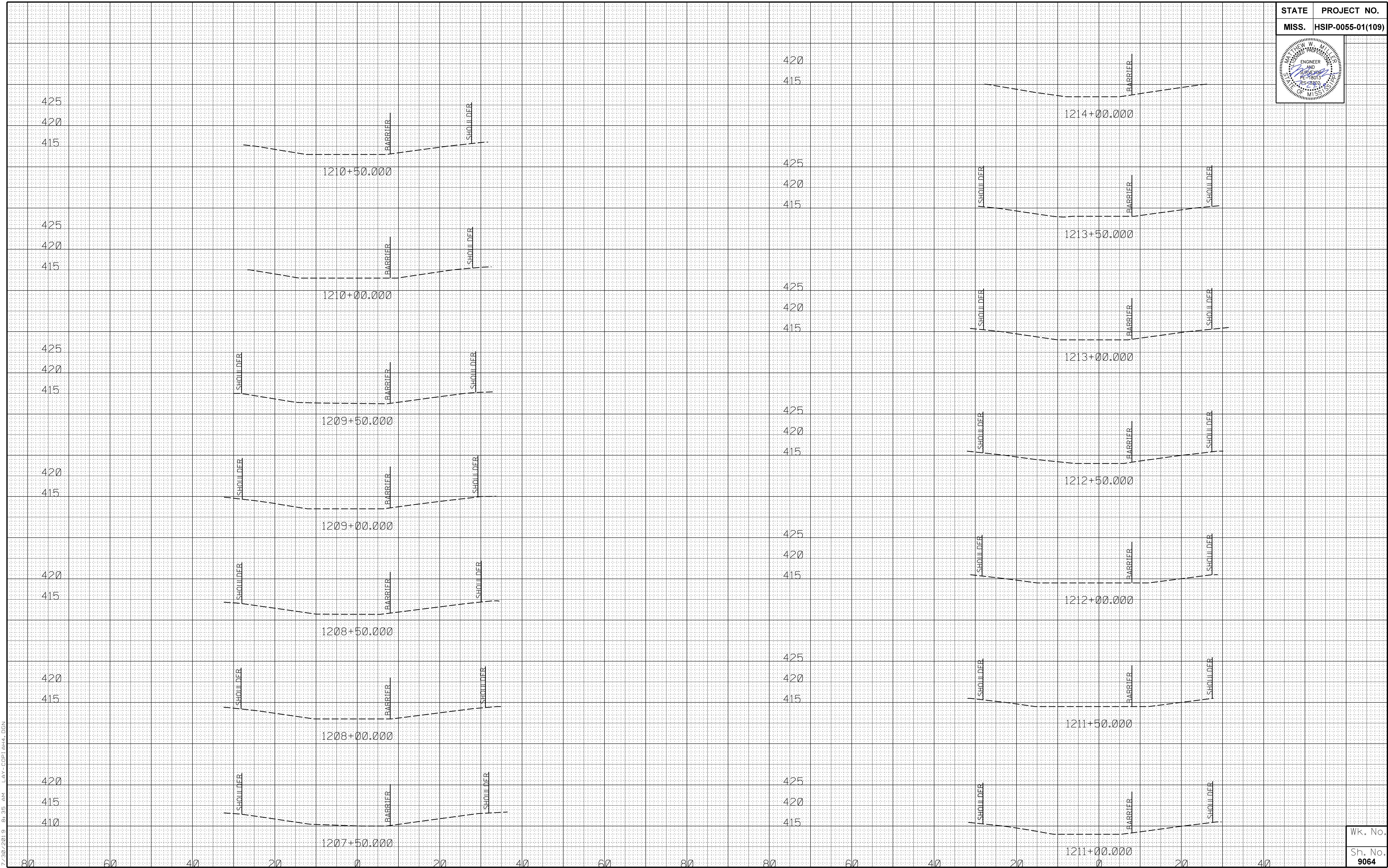
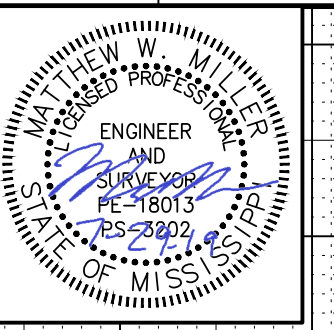

7/30/2019 8:35 AM LAY-COPI-AH4.DGN

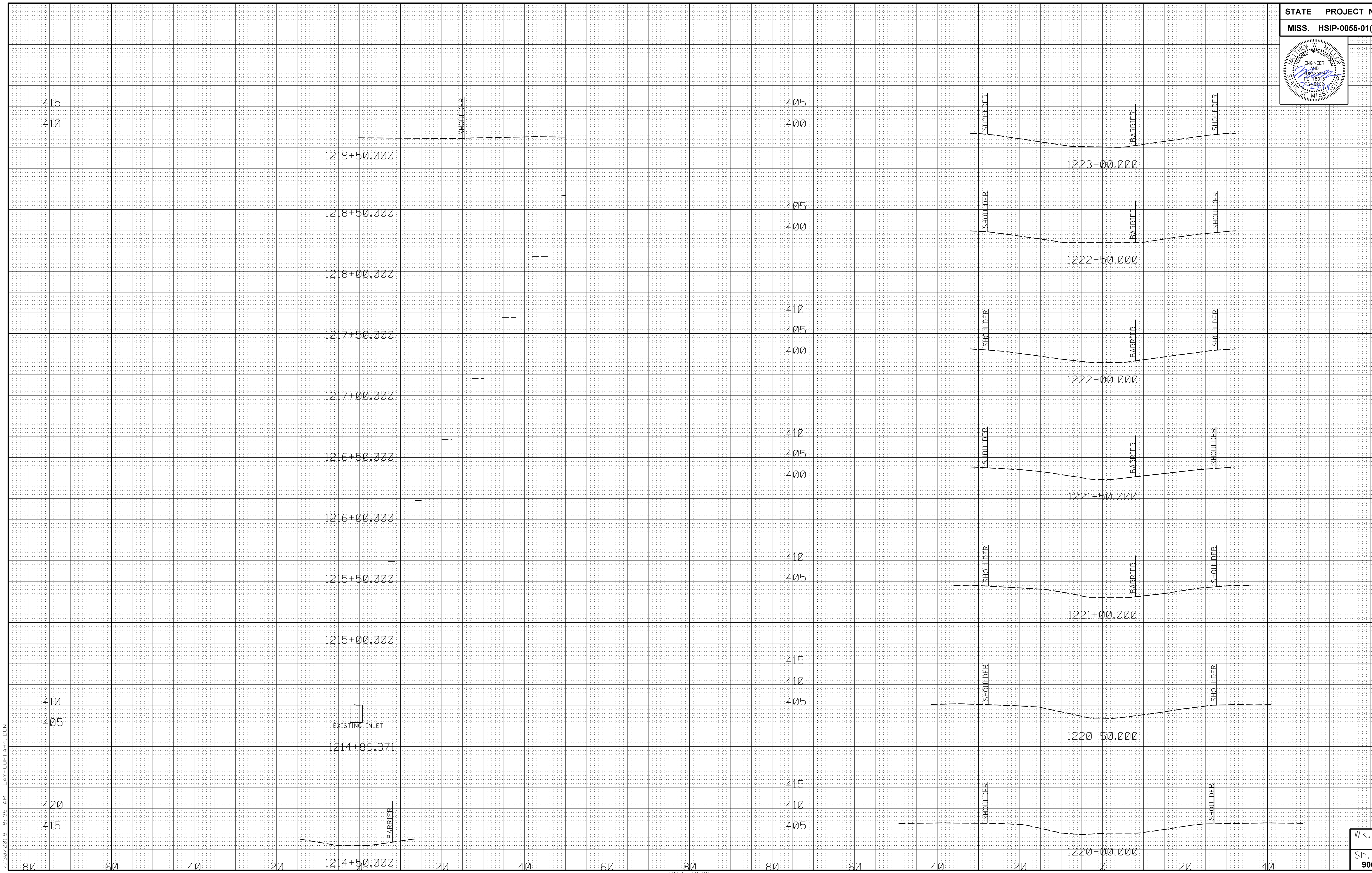
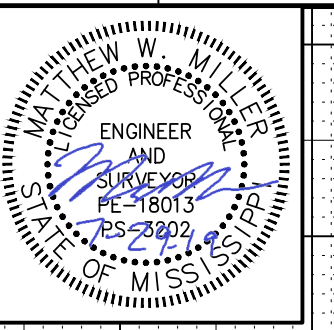

7/30/2019 8:35 AM LAY-COPI-AH4.DGN

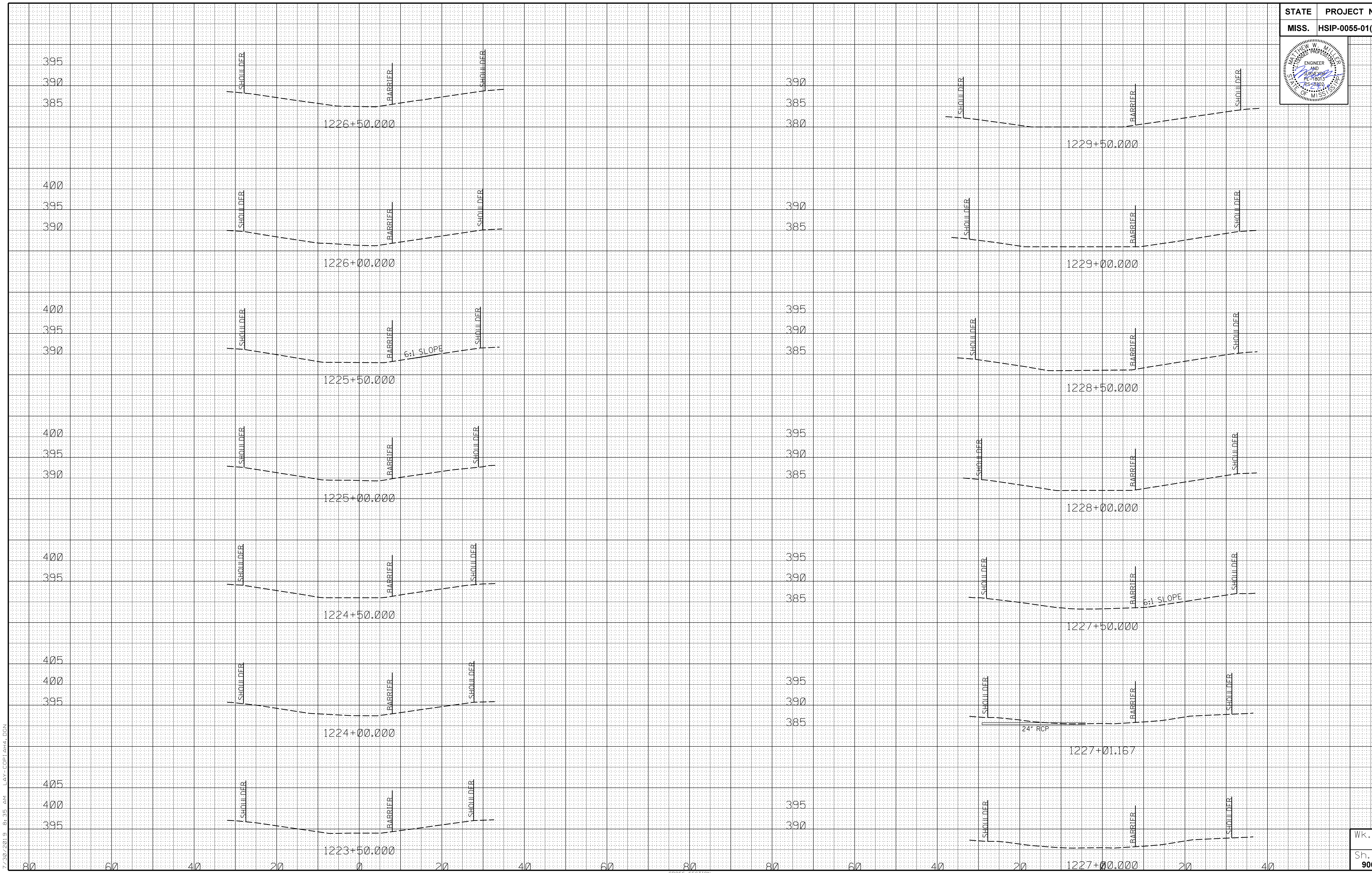
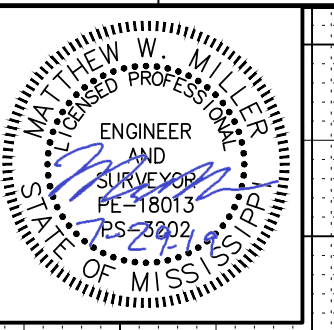

7/30/2019 8:35 AM LAY-COPI-AH4.DGN

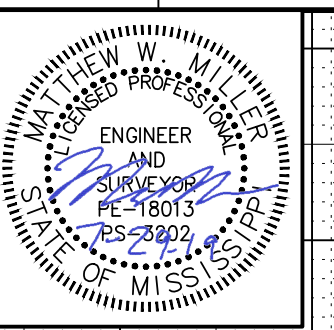

7/30/2019 8:35 AM LAY-COPI-AH4.DGN

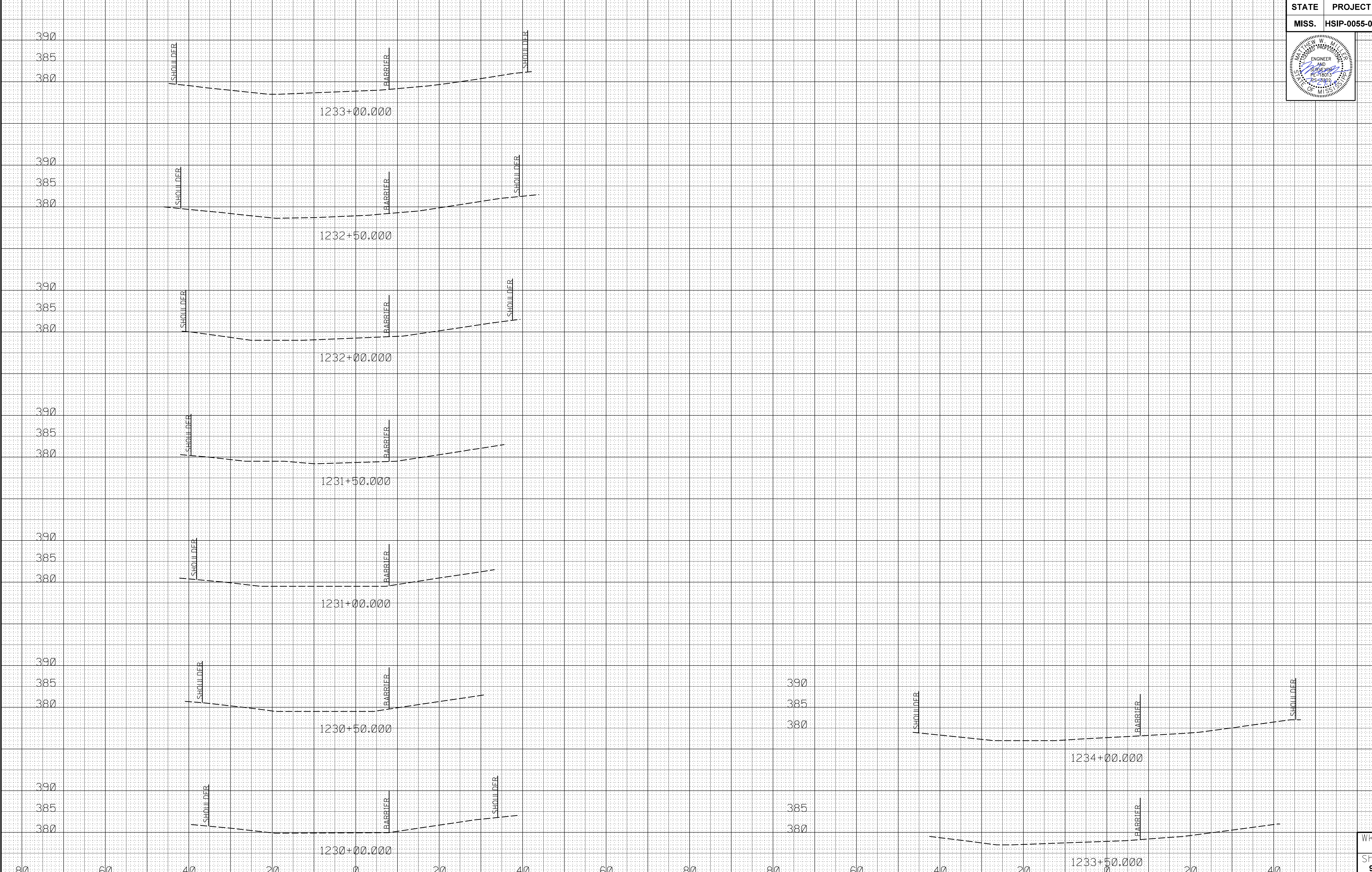

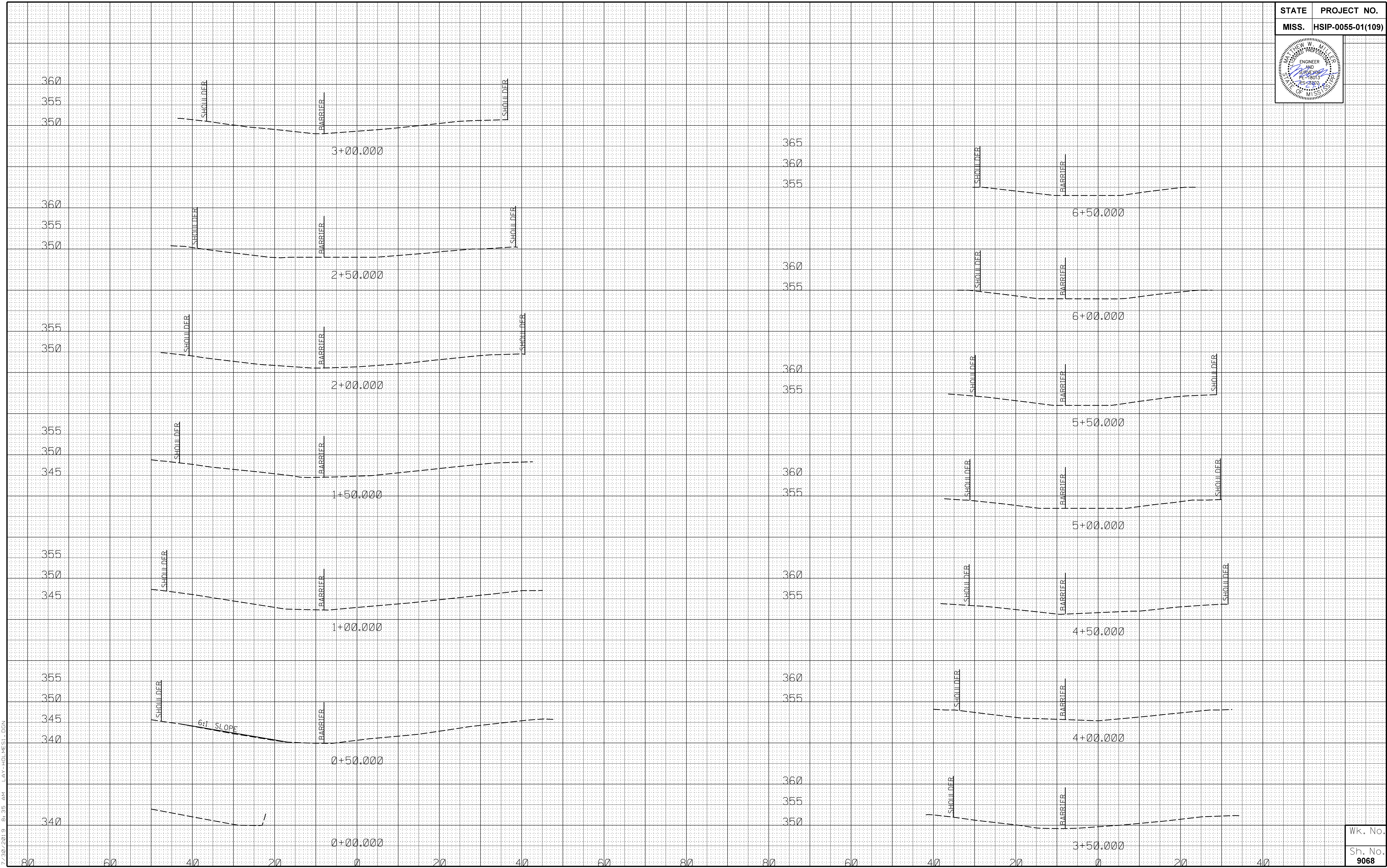
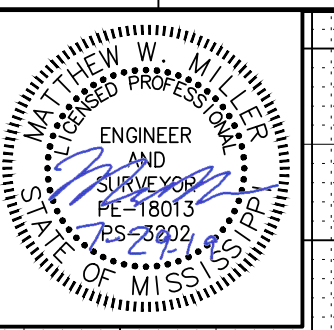

7/30/2019 8:35 AM LAY-HOLMES1.DGN

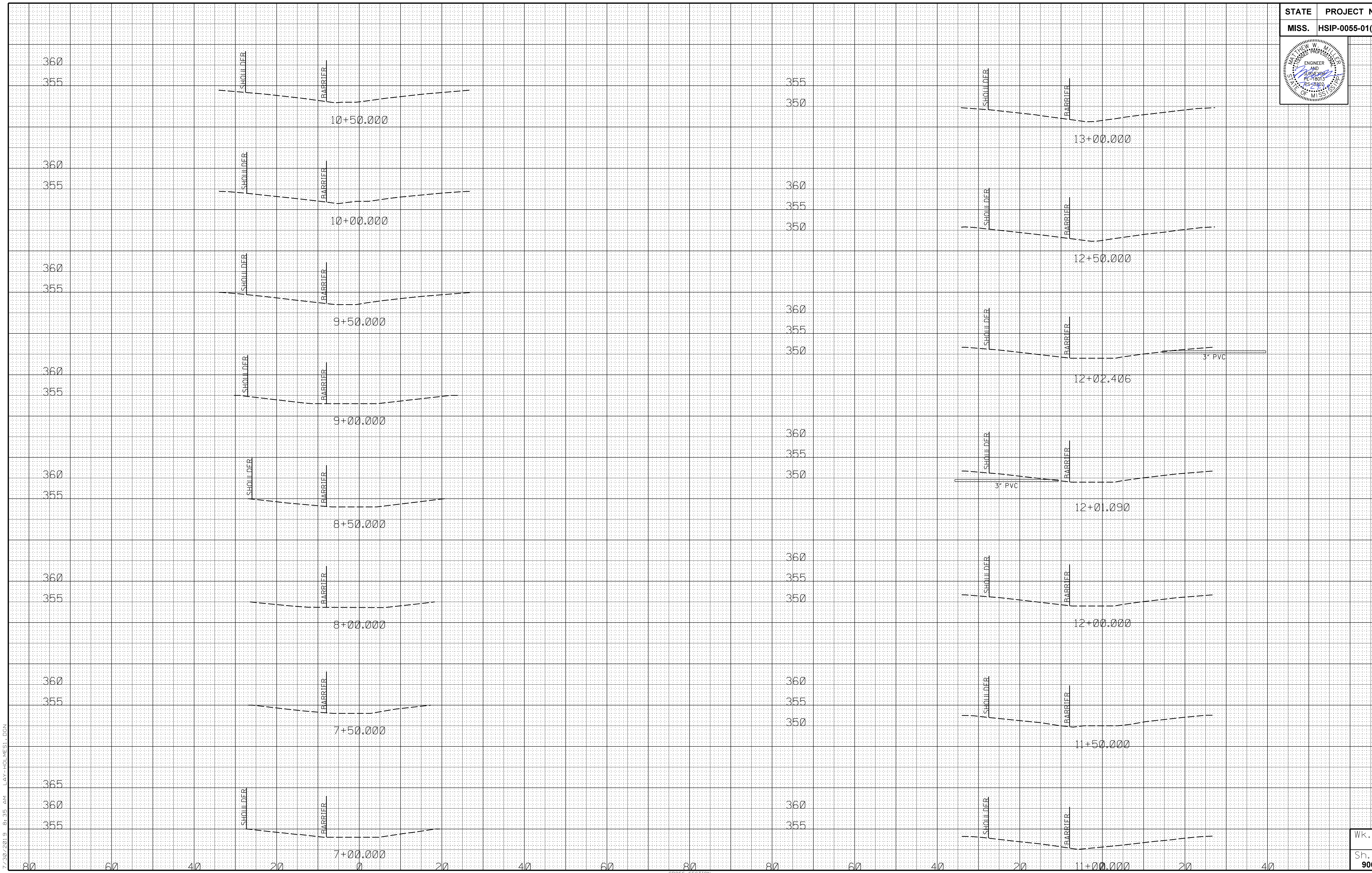
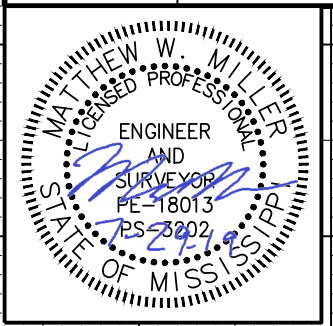

7/20/2019 8:35 AM LAY-HOLMES1.DGN

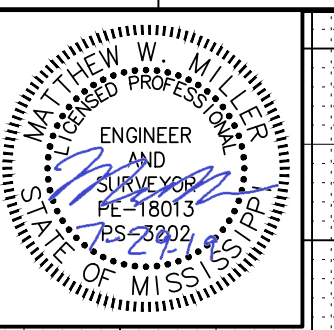

350
345
340
350
345
355
350
345
355
350
345
355
350
345
355
350
345
355
350
345

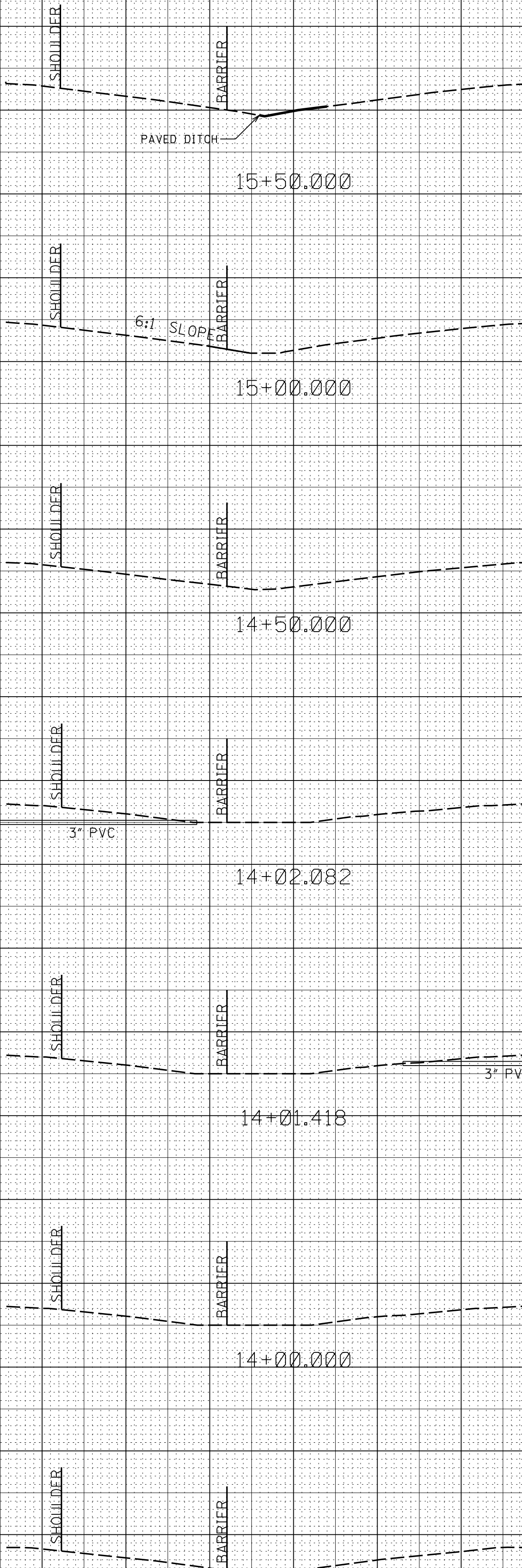

345
340
335
345
340
335
345
340
335
345
340
335
350
345
340
335

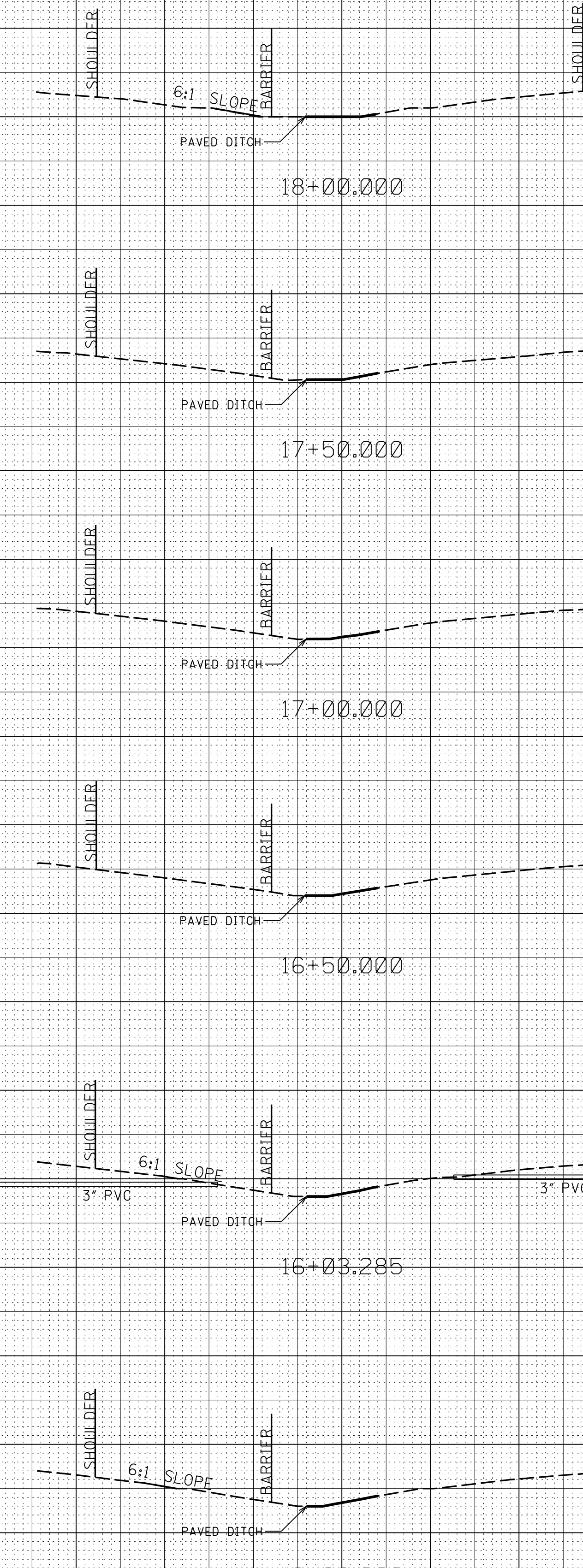

7/30/2019 8:35 AM LAY-HOLMES1.DGN

80 60 40 20 13+50.000 20 40 60 80 80 60 40 20 0 20 40

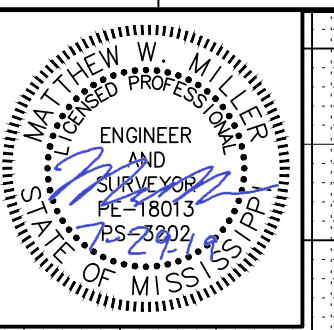

345
340
335
330

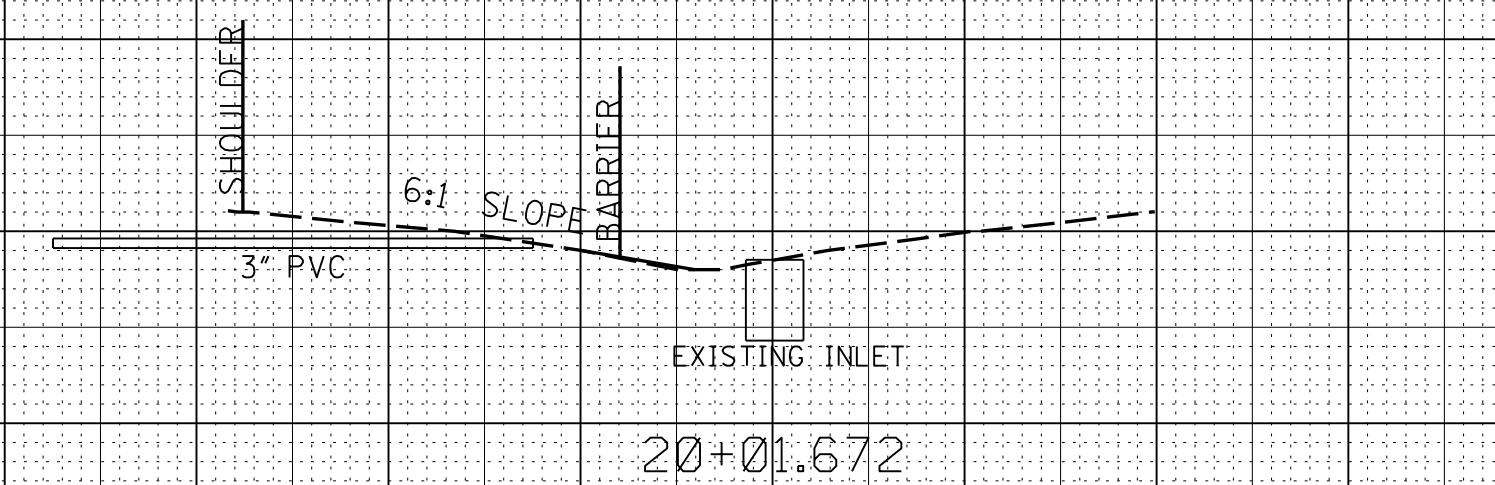

20+01.672

345
340
335
330

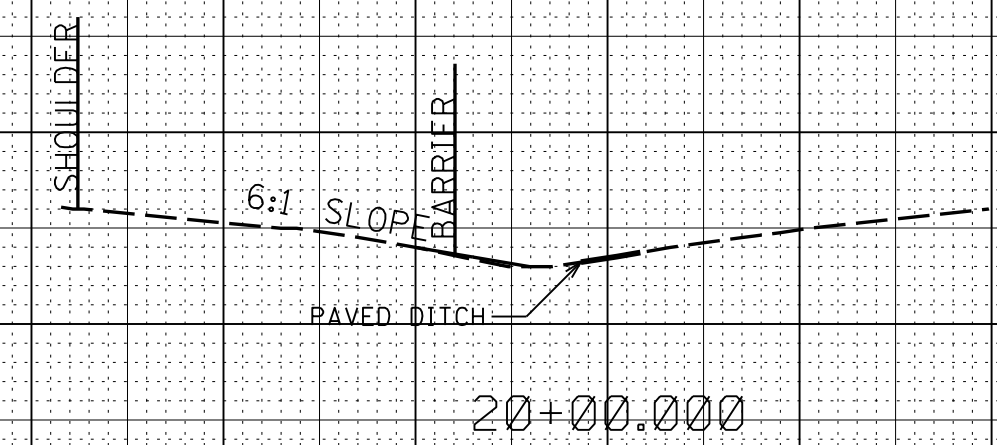

20+00.000

345
340
335

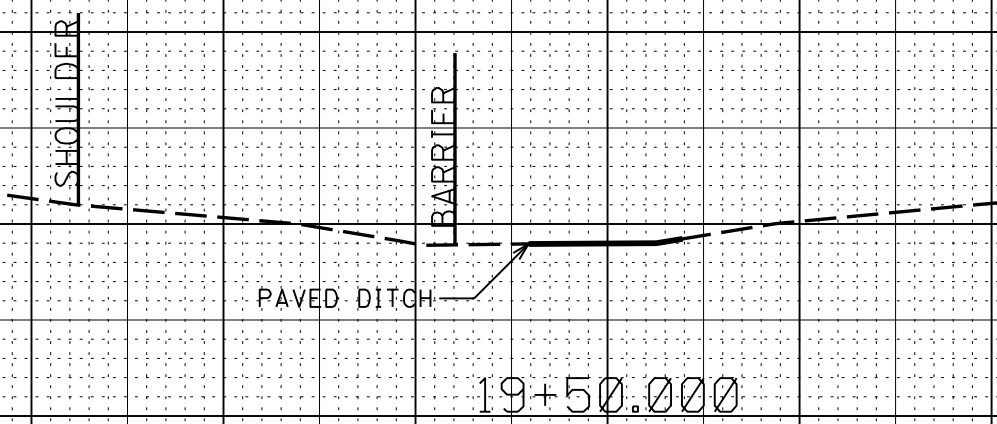

19+50.000

345
340
335

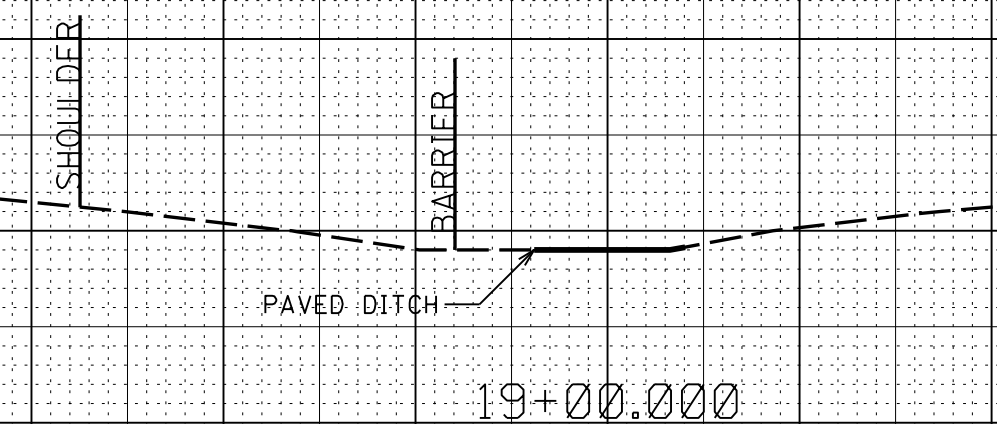

19+00.000

345
340
335

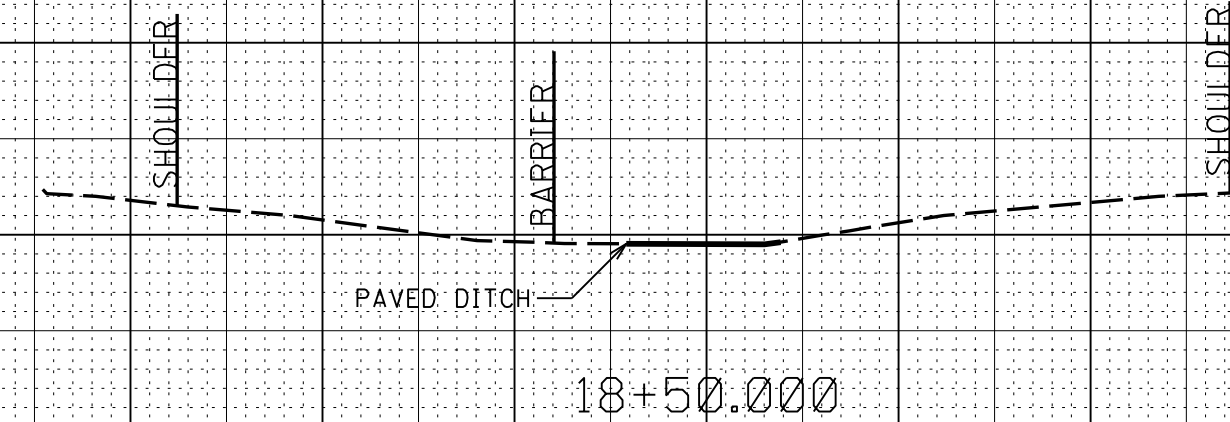

18+50.000

345
340
335

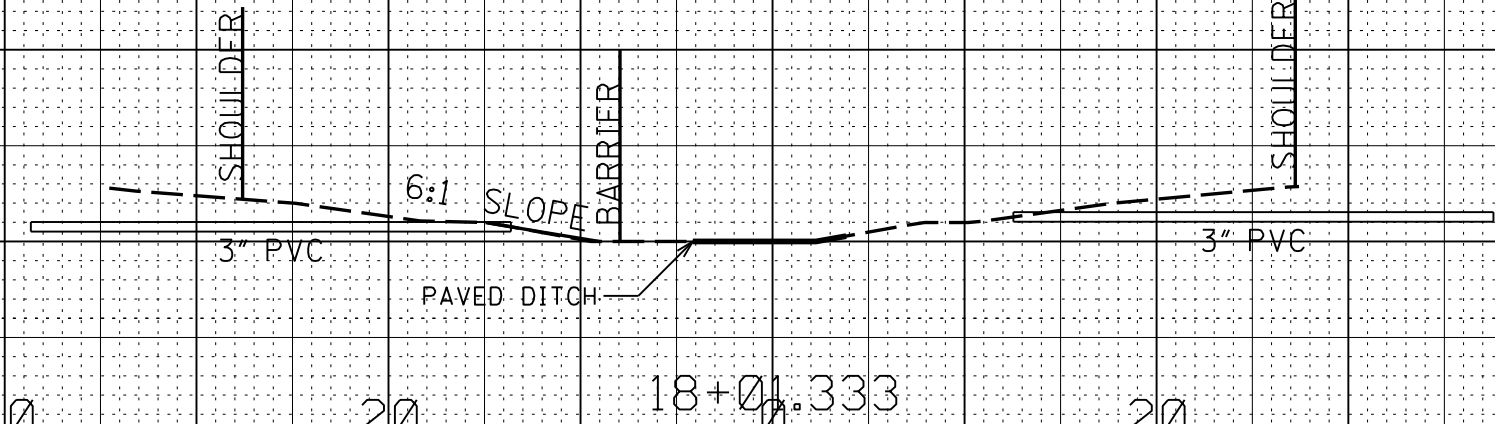

18+01.333

345
340
335

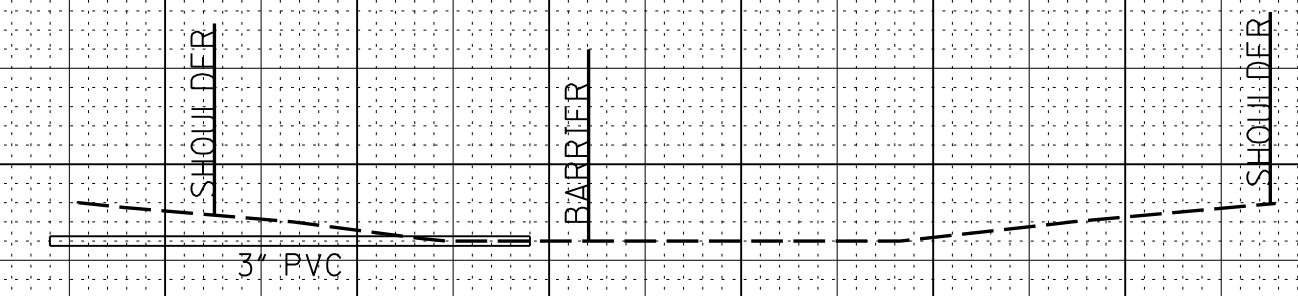

22+02.432

345
340
335

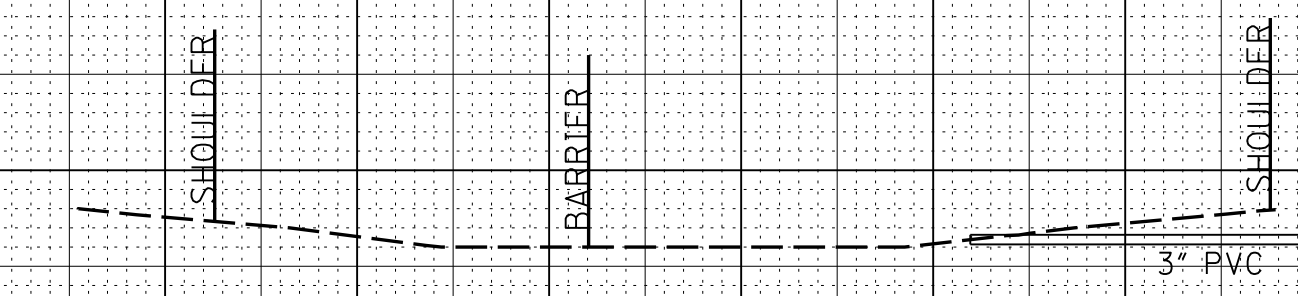

22+00.957

345
340

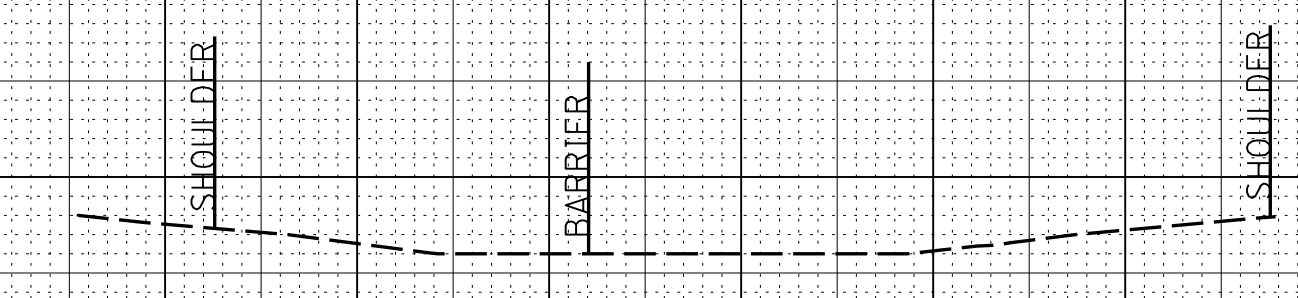

22+00.000

345
340
335

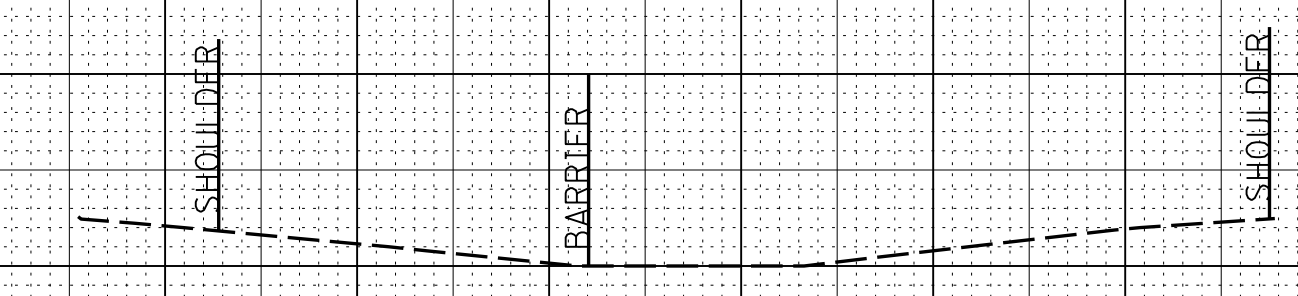

21+50.000

345
340
335

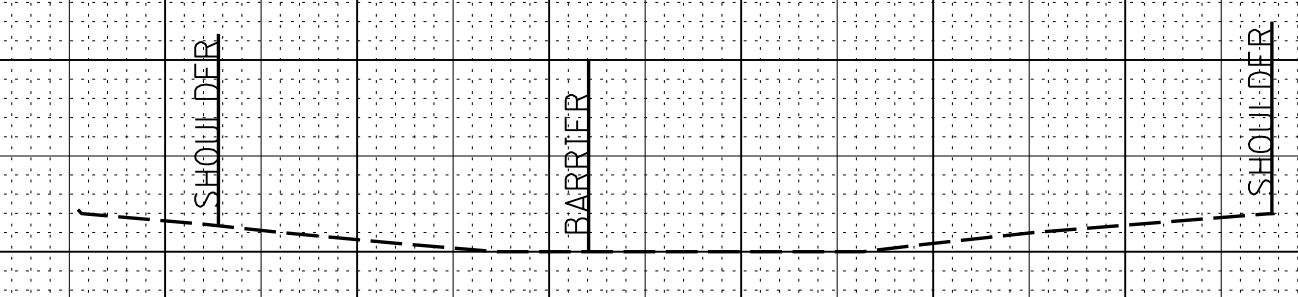

21+00.000

345
340
335

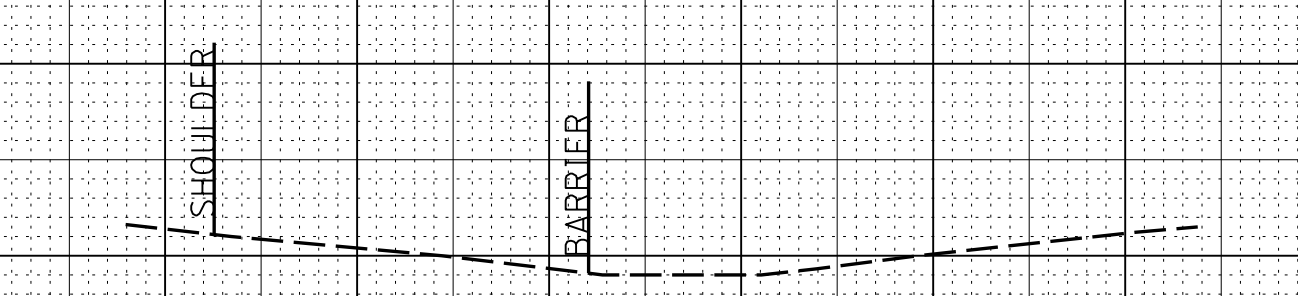

20+50.000

345
340
335

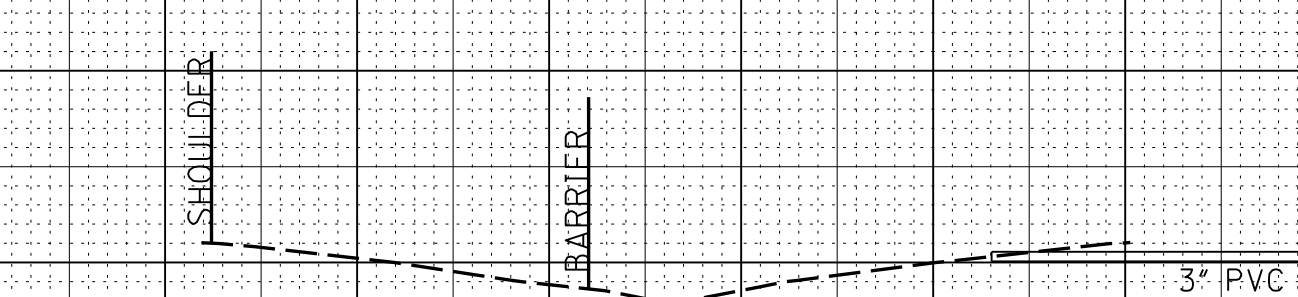

20+06.163

7/30/2019 8:35 AM LAY-HOLMESI.DGN

80 60 40 20 0 20 40 60 80 80 60 40 20 0 20 40

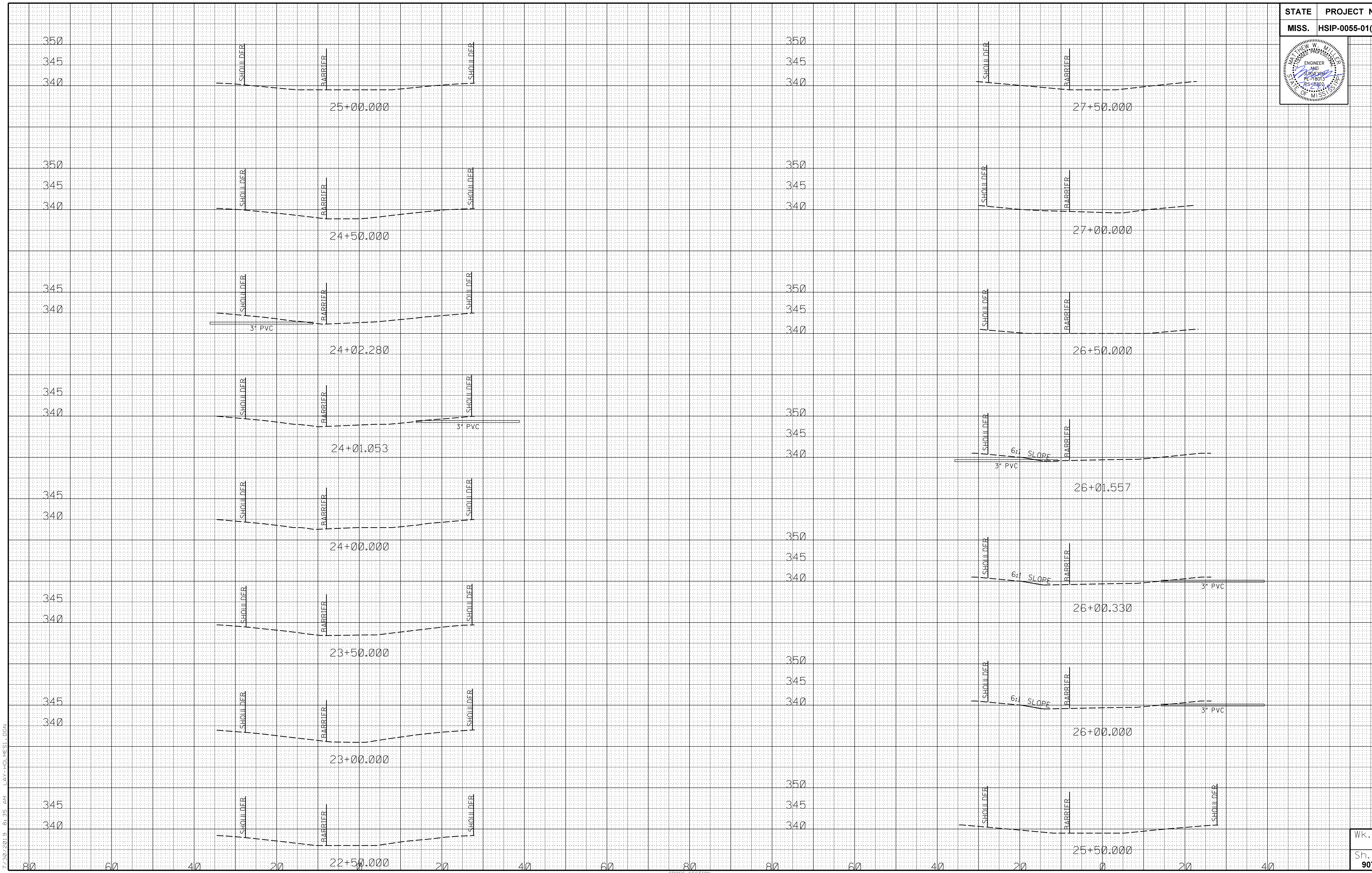
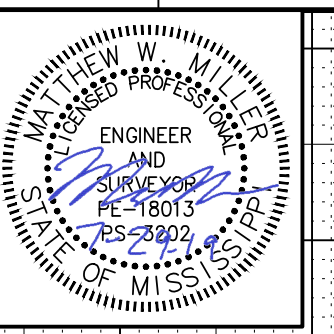

7/20/2019 8:35 AM LAY-HOLMES1.DGN

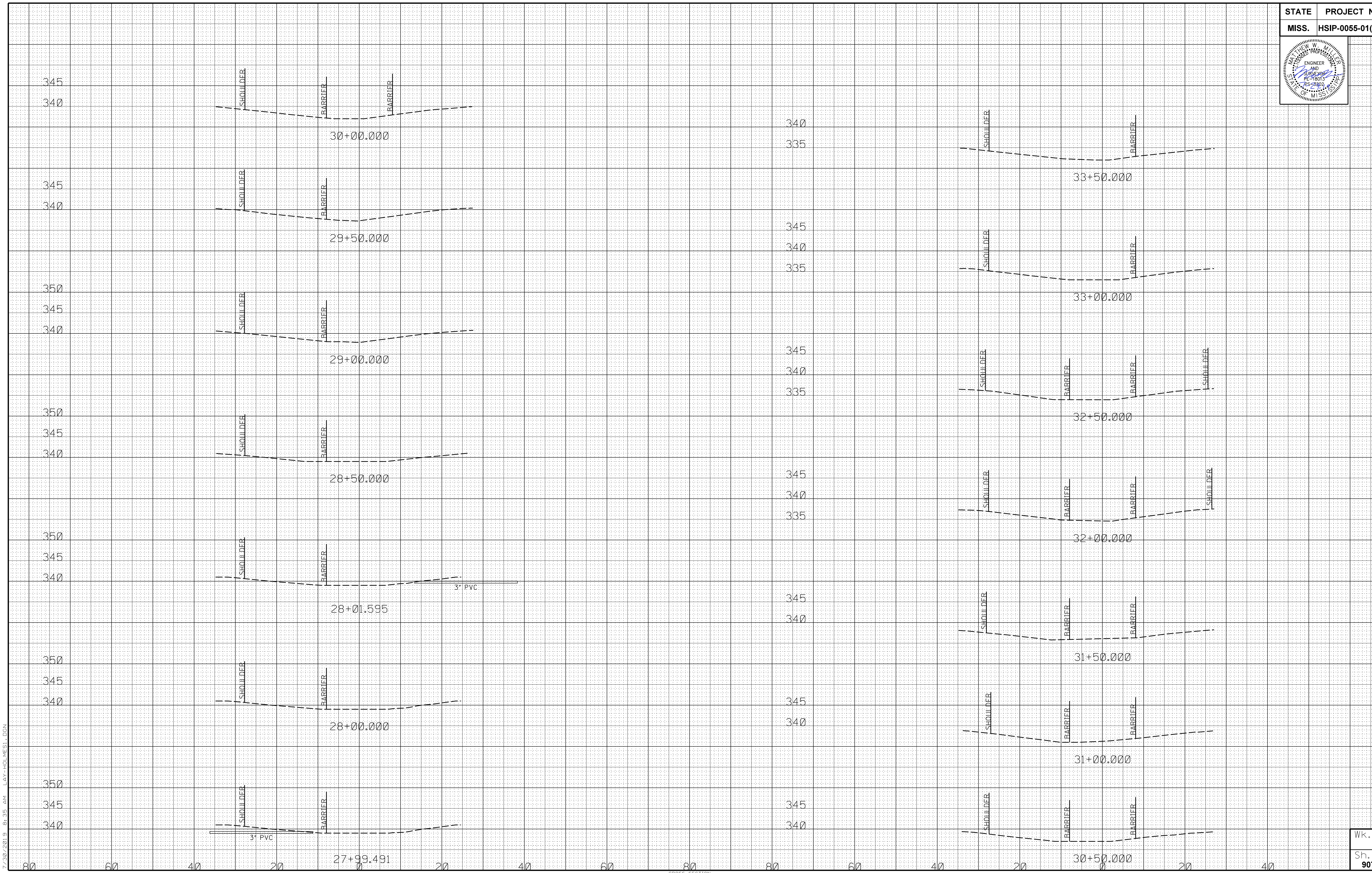
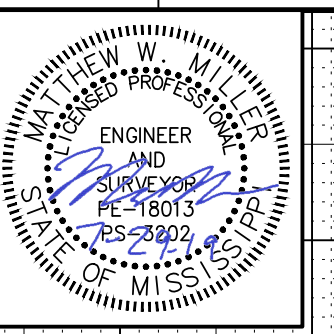

7/30/2019 8:35 AM LAY-HOLMES1.DGN

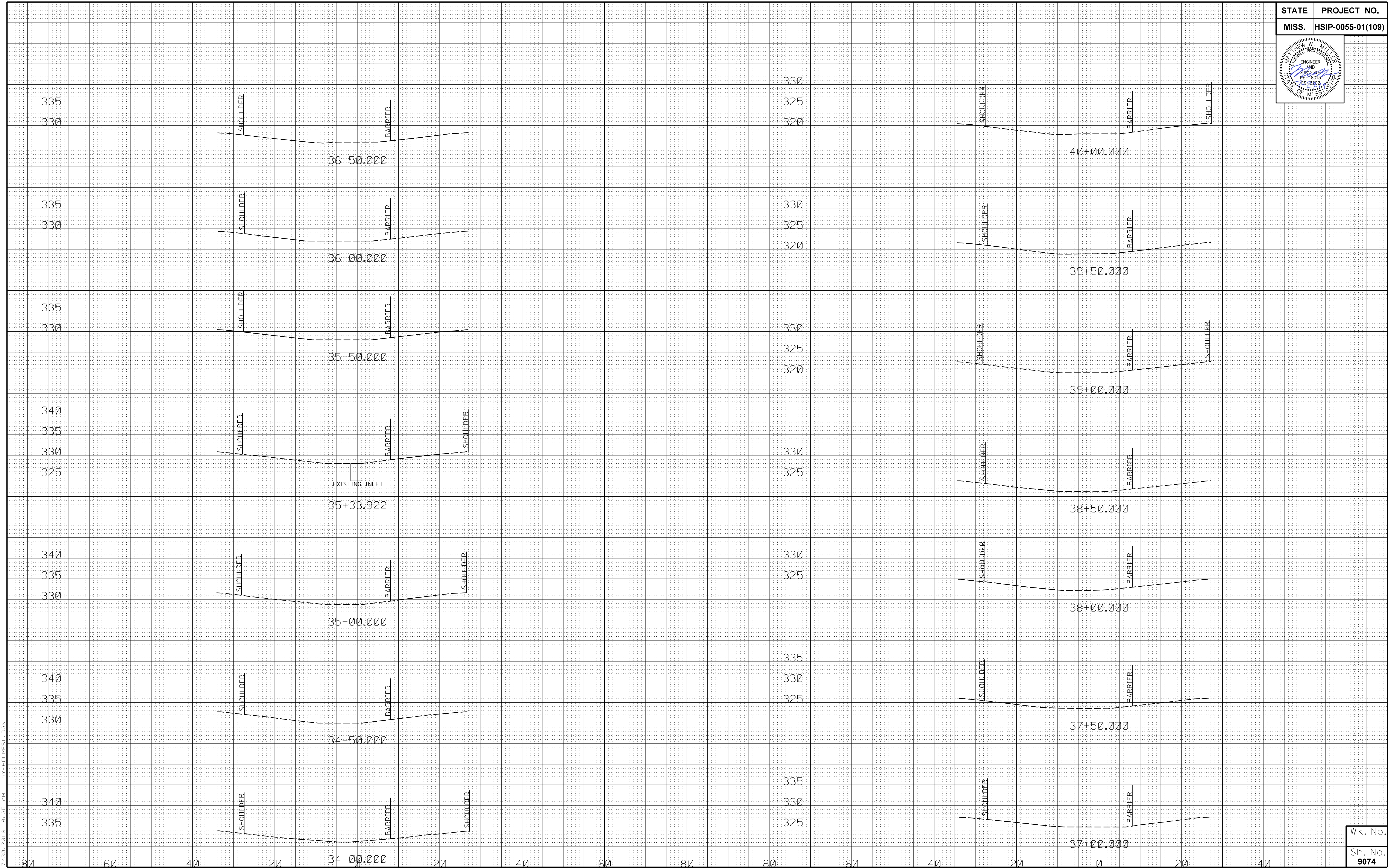
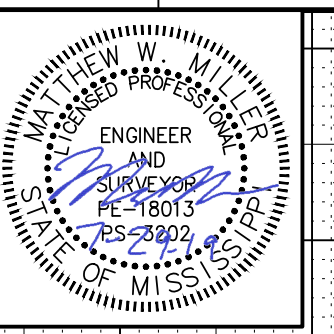

7/30/2019 8:35 AM LAY-HOLMES1.DGN

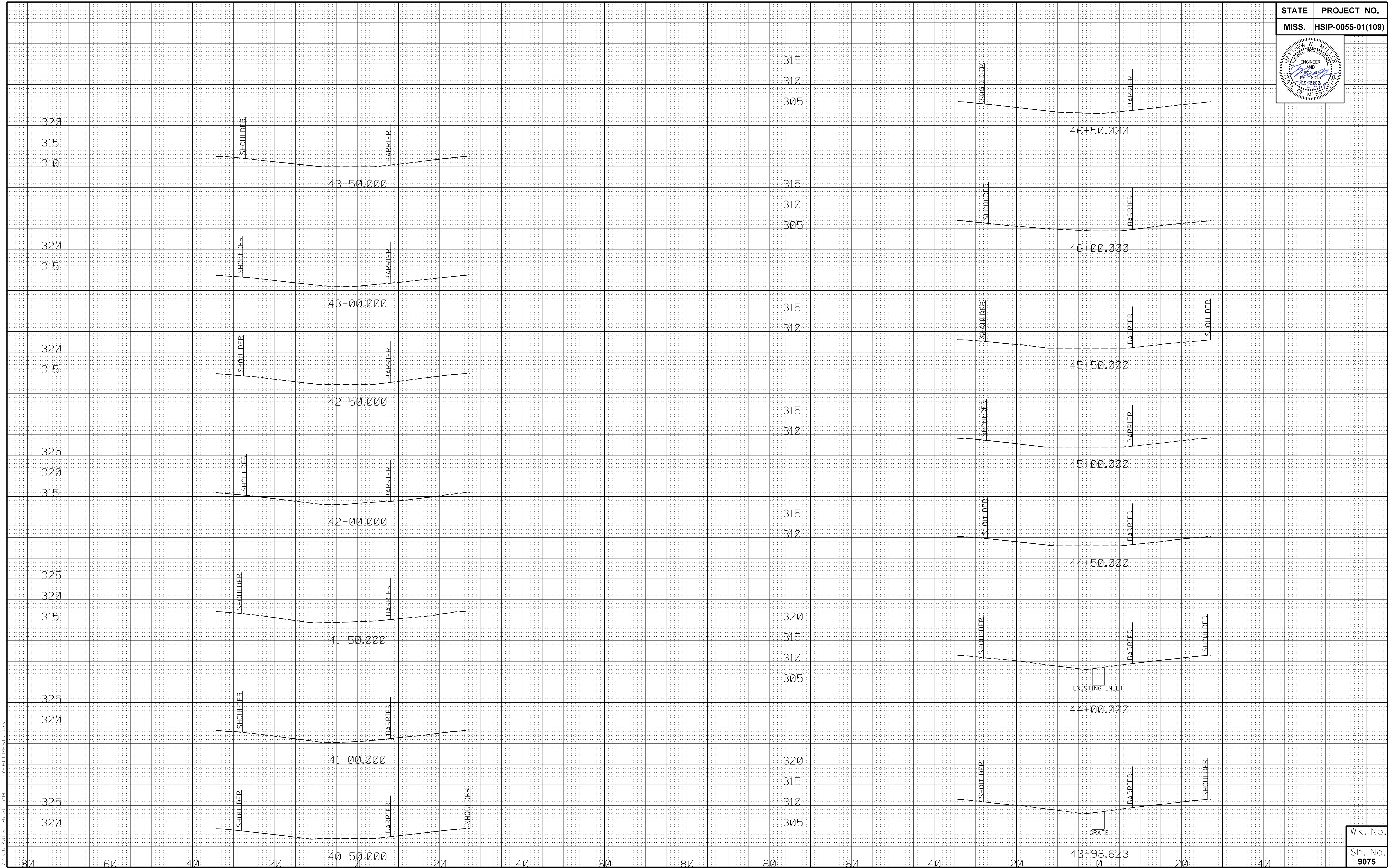
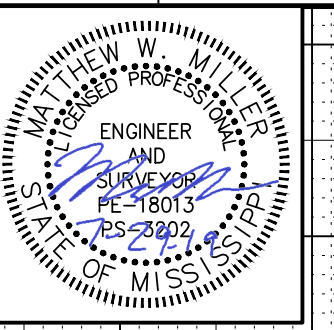

7/30/2019 8:35 AM LAY-HOLMESI.DGN

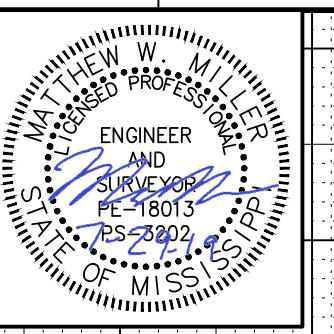

305
300
305
300
310
305
300
310
305
300
310
305
300
310
305
300
310
305
300

305
300
295
305
300
295
305
300
295
305
300
295
305
300
295
305
300
295
305
300
295

50+00.000

49+50.000

49+00.000

48+50.000

48+00.000

47+50.000

47+00.000

53+50.000

53+00.000

52+50.000

52+00.000

51+50.000

51+00.000

50+50.000

SHOULDER

BARRIER

SHOULDER

BARRIER

SHOULDER

BARRIER

SHOULDER

SHOULDER

BARRIER

SHOULDER

BARRIER

SHOULDER

BARRIER

SHOULDER

BARRIER

SHOULDER

BARRIER

SHOULDER

BARRIER

SHOULDER

BARRIER

SHOULDER

BARRIER

SHOULDER

BARRIER

SHOULDER

BARRIER

SHOULDER

BARRIER

7/20/2019 8:35 AM LAY-HOLMES.DGN

80 60 40 20 0 20 40 60 80 80 60 40 20 40 20 40 20 40

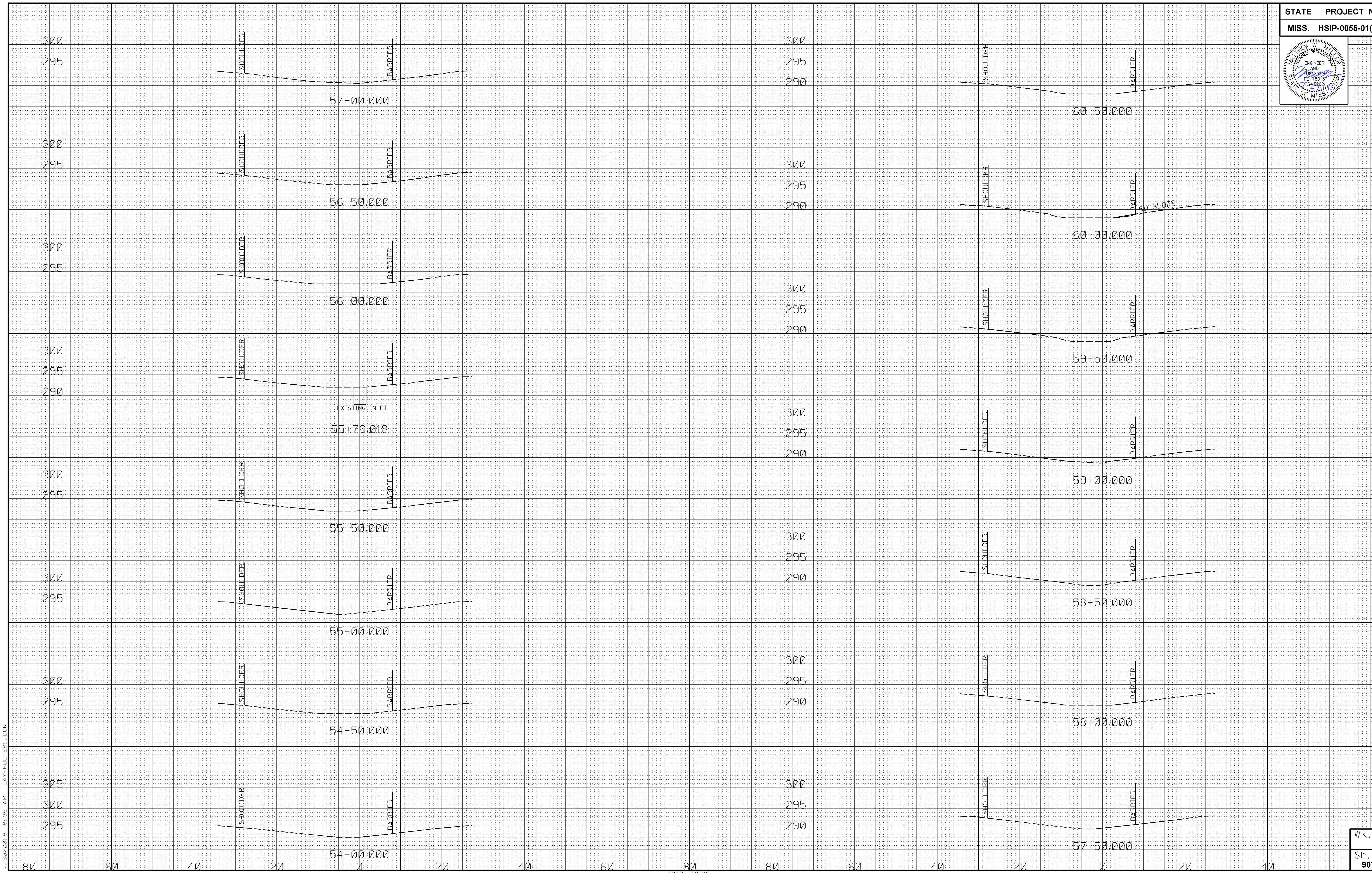
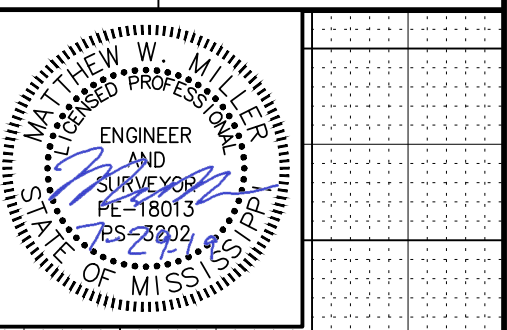

7/30/2019 8:35 AM LAY-HOLMES1.DGN

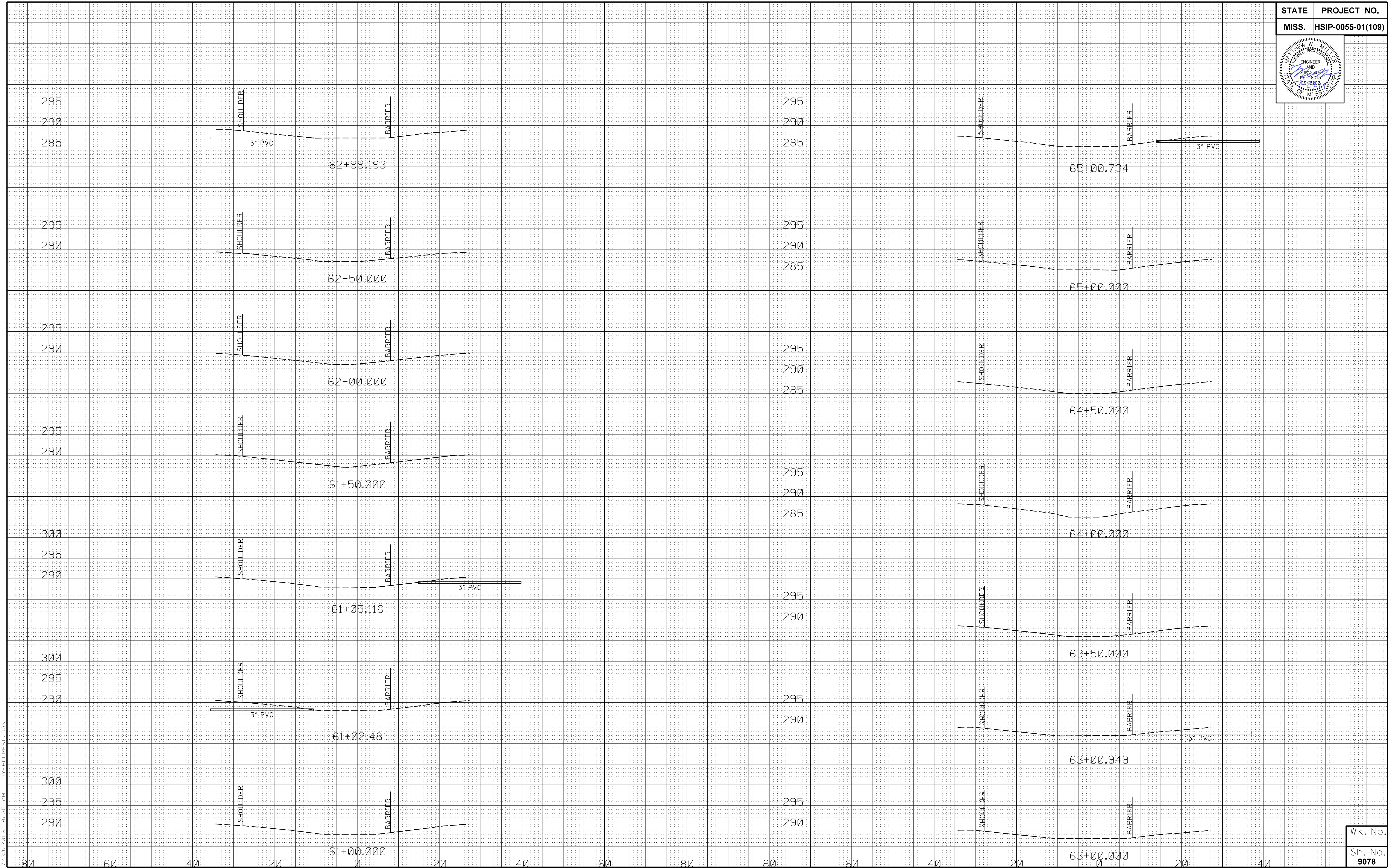
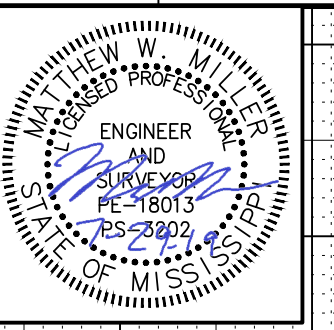

7/30/2019 8:35 AM LAY-HOLMES1.DGN

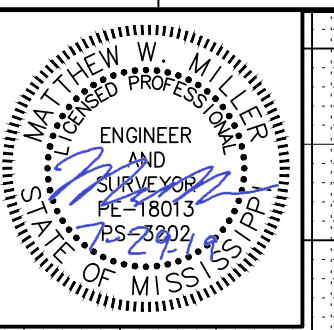

295
290
285
295
290
285
295
290
285
295
290
285
295
290
285
295
290
285
295
290
285
295
290
285
295
290
285

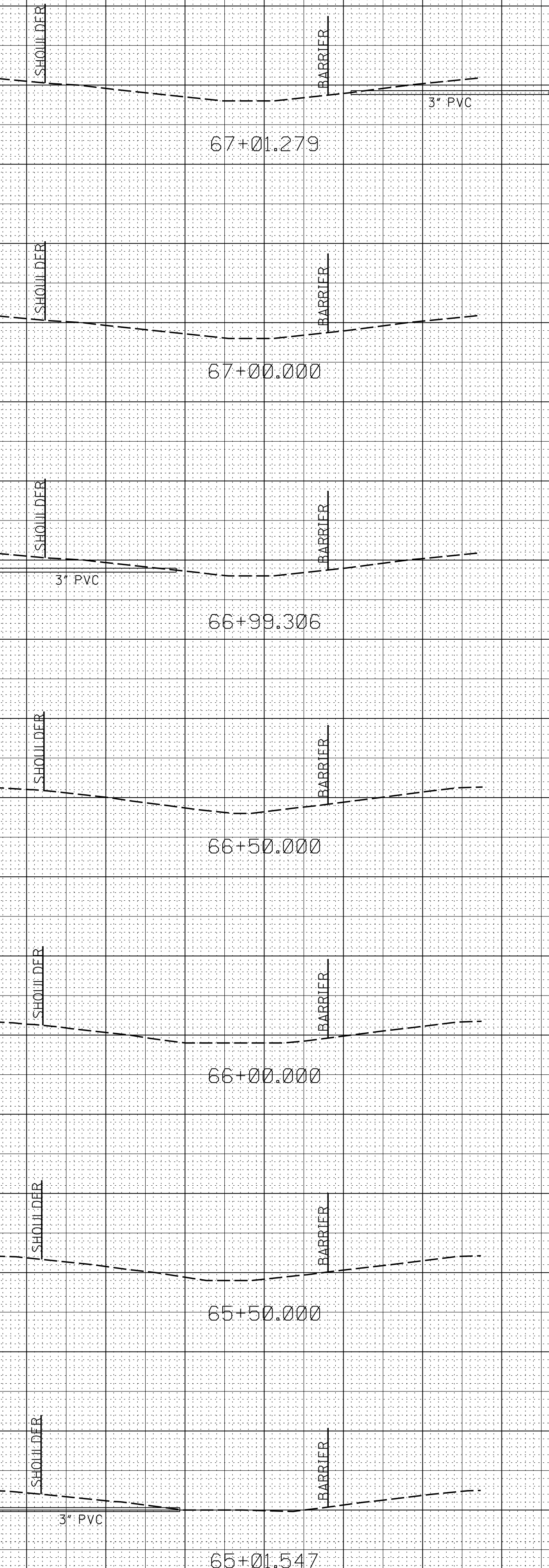

290
285
290
285
290
285
290
285
290
285
290
285
290
285
290
285
290
285
290
285
290
285
290
285
290
285

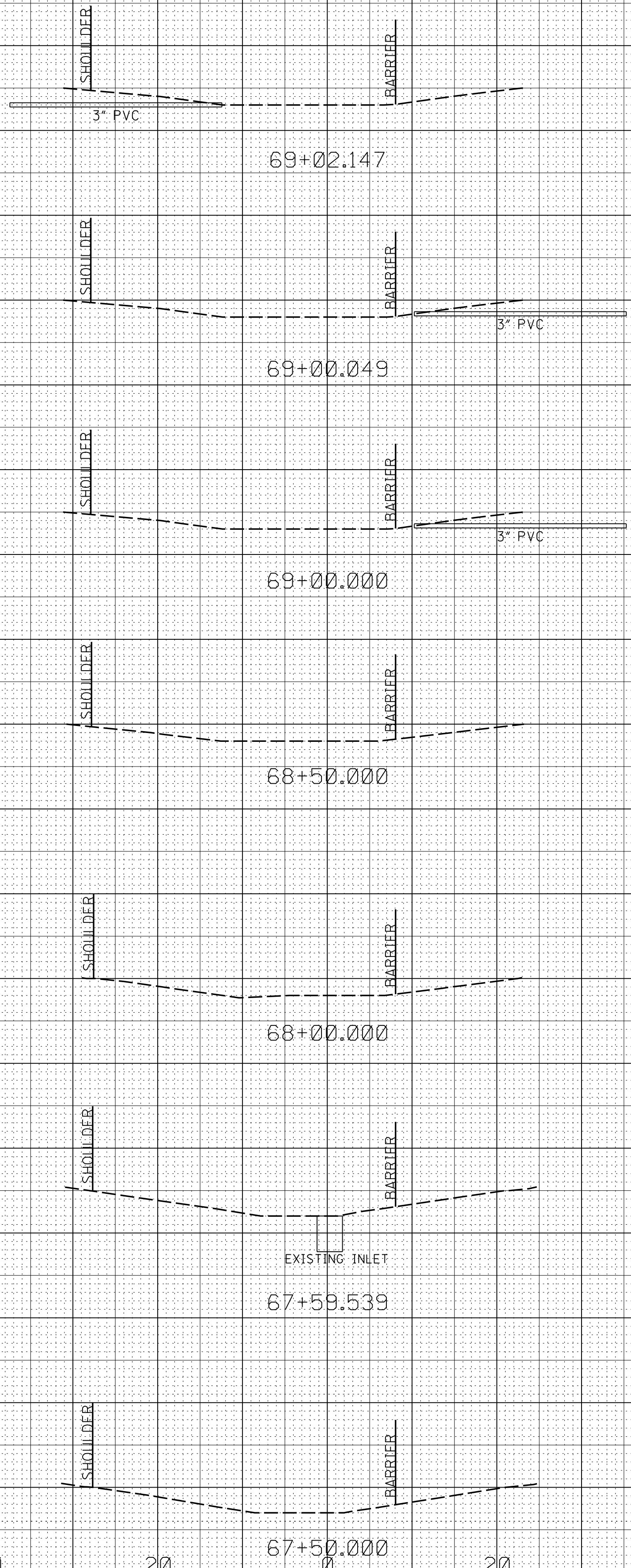

7/30/2019 8:35 AM LAY-HOLMESI.DGN

80 60 40 20 0 20 40 60 80 80 60 40 20 0 20 40

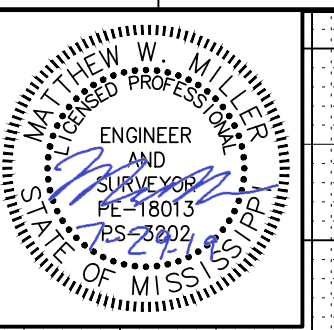

7/30/2019 8:35 AM LAY-HOLMES1.DGN

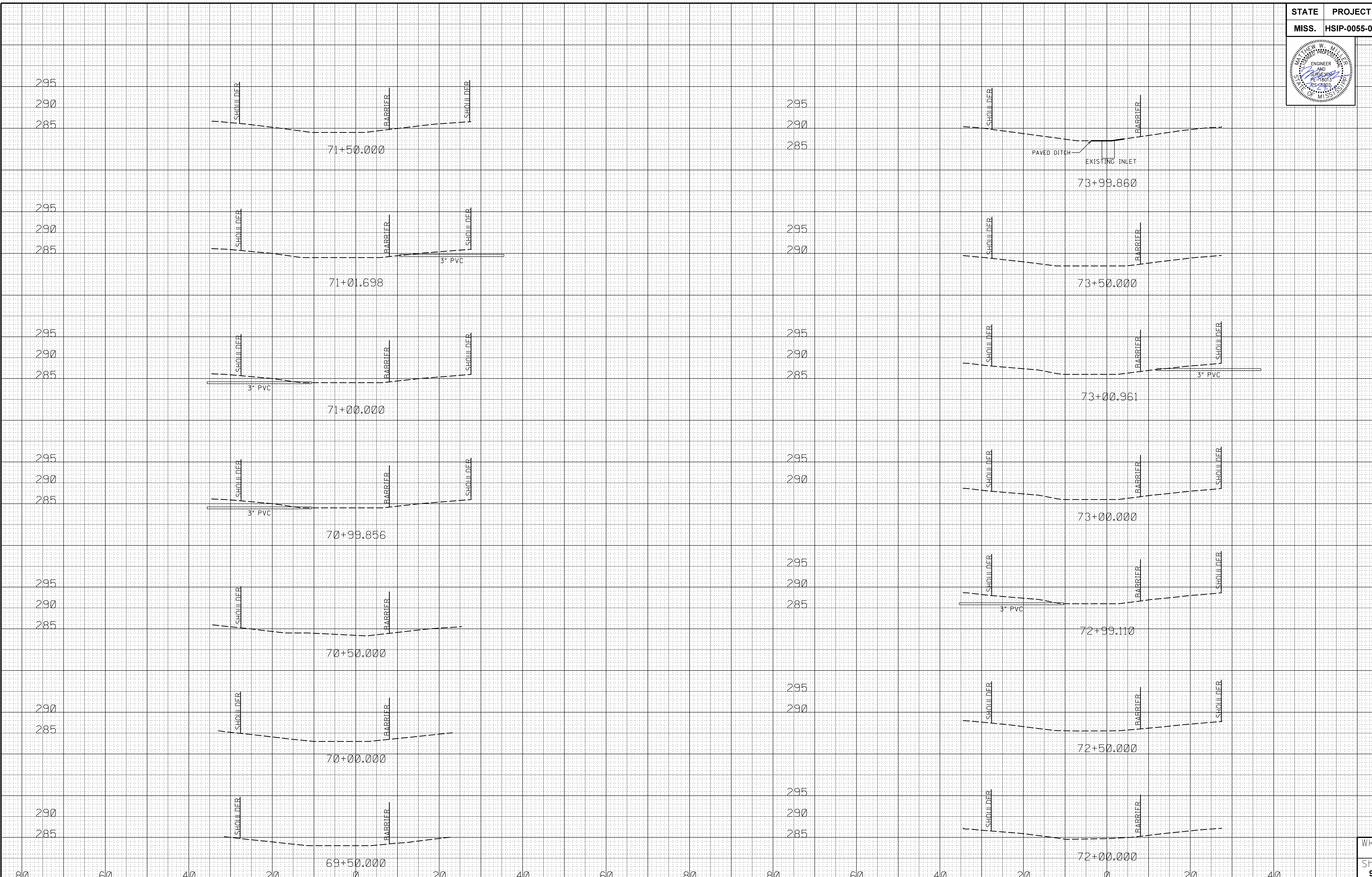

Wk. No.

Sh. No. 9080

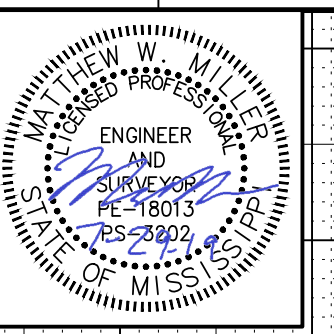

7/30/2019 8:35 AM LAY-HOLMES1.DGN

300
295
290

300
295
290

300
295
290

300
295
290

300
295
290
285

295
290
285

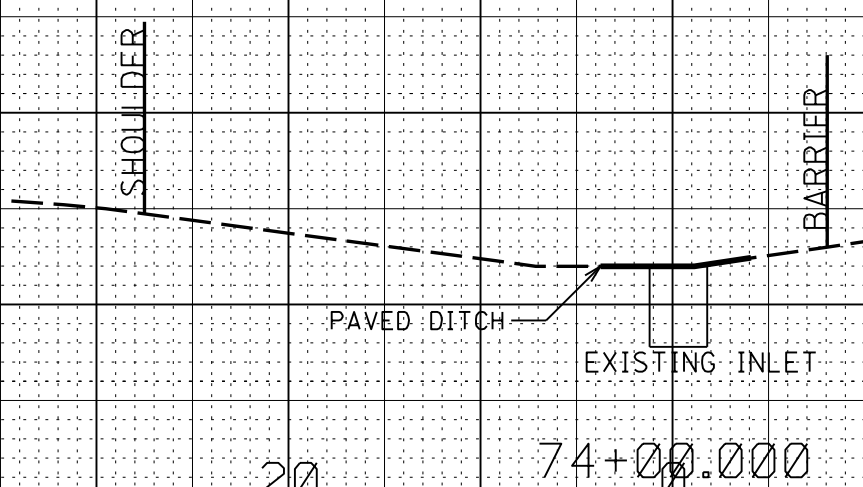
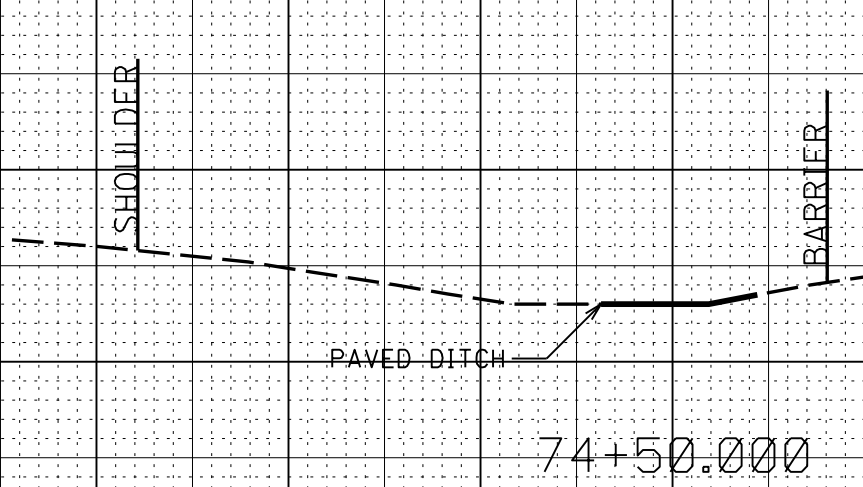
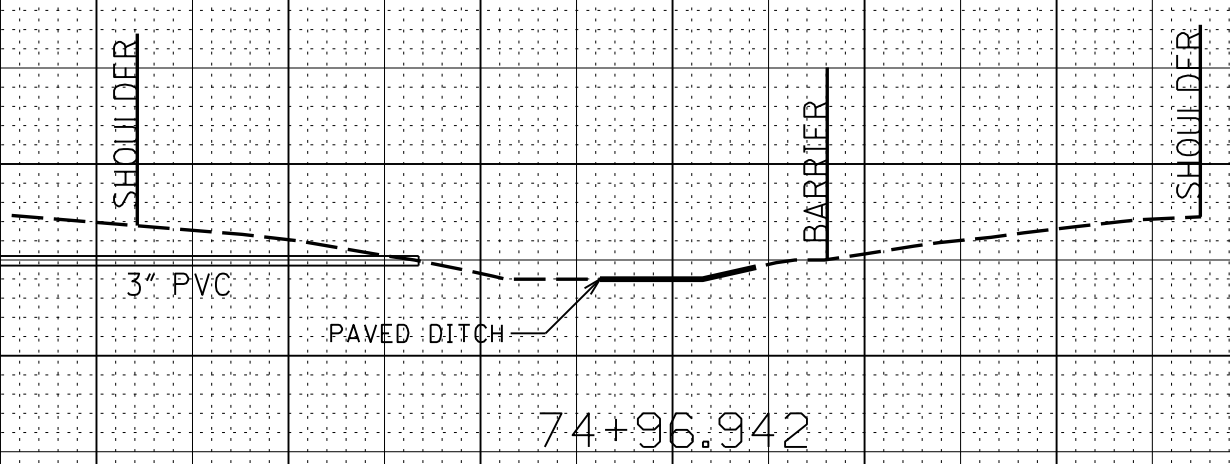
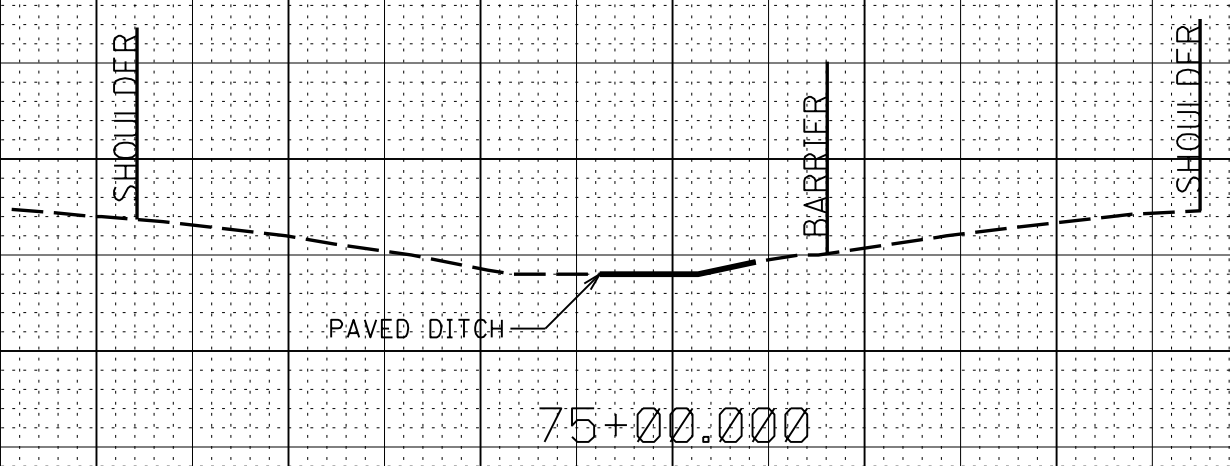
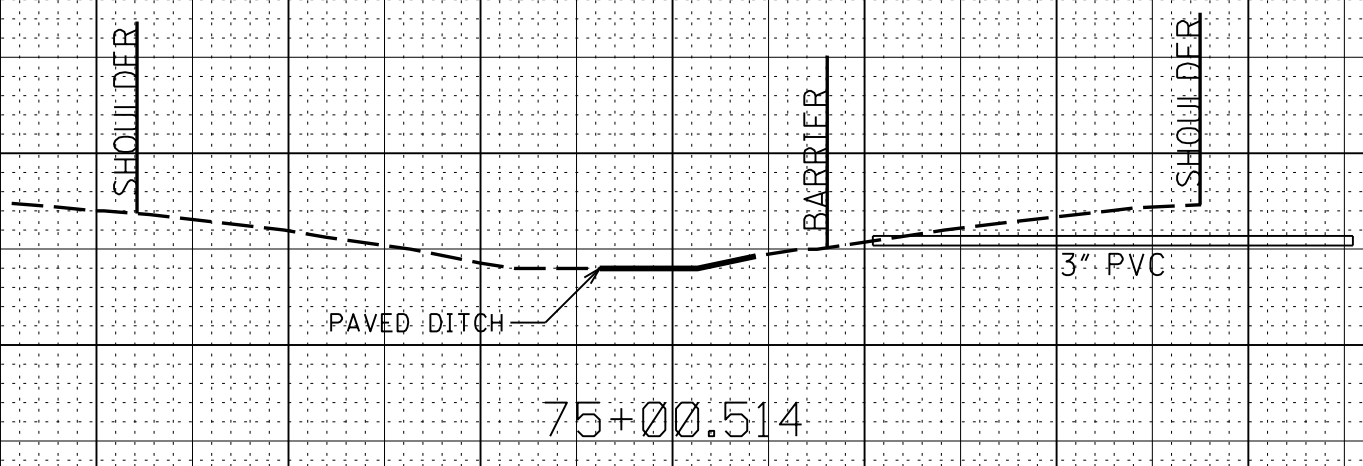
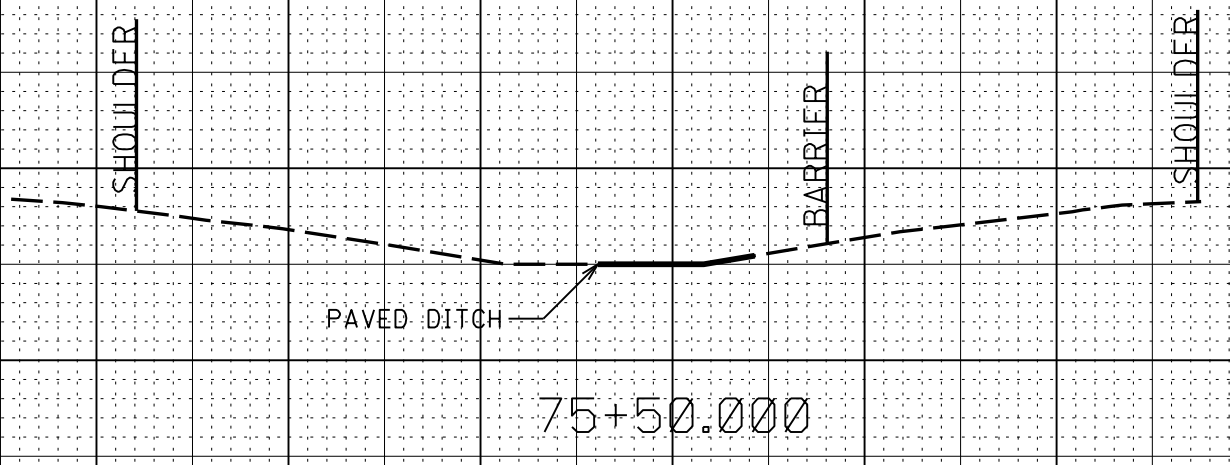

305
300
295

305
300
295
290

305
300
295
290

305
300
295
290

305
300
295
290

300
295
290

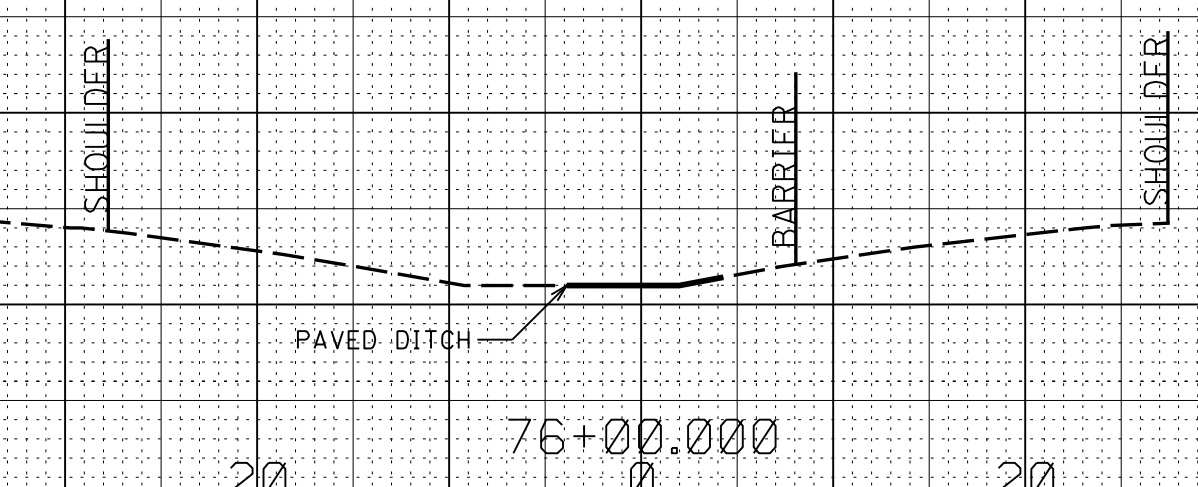
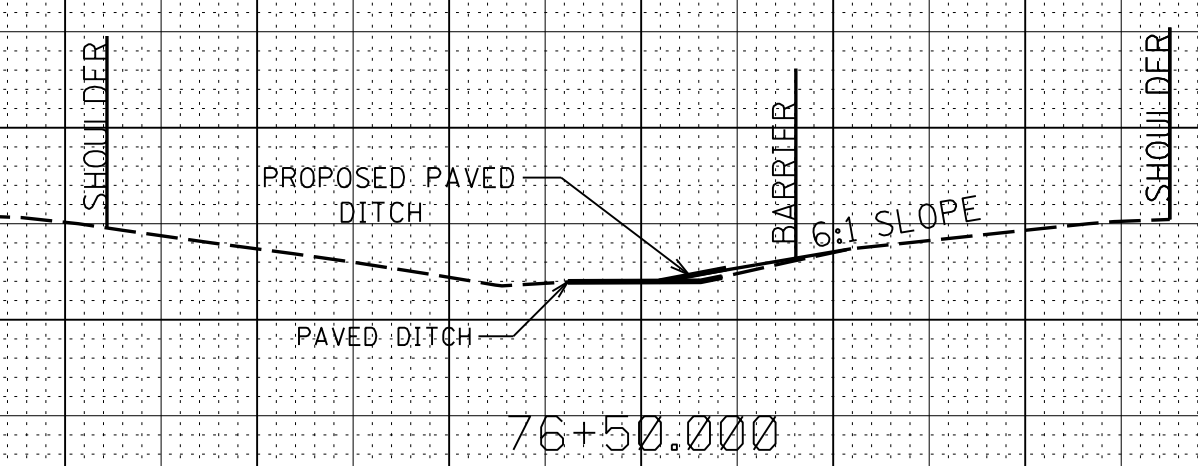
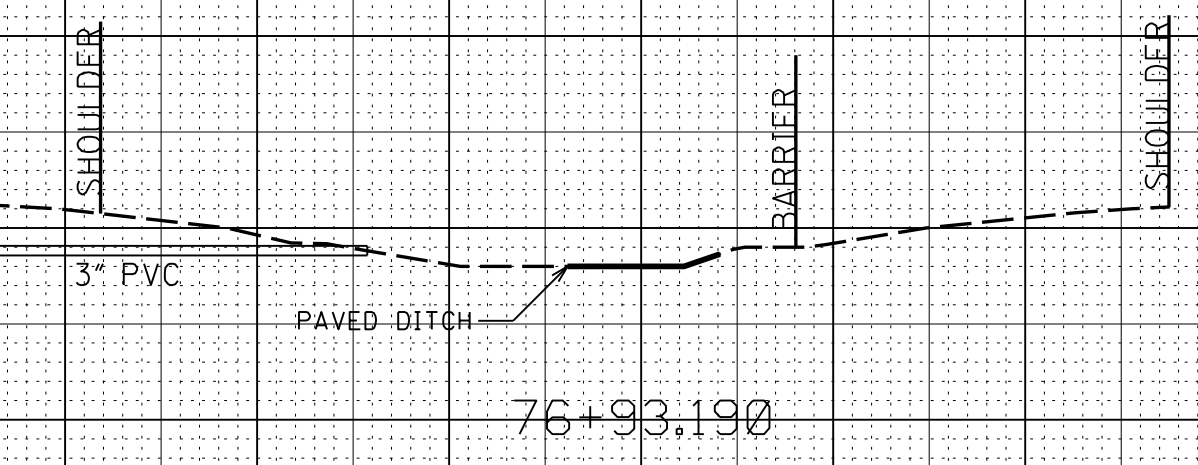
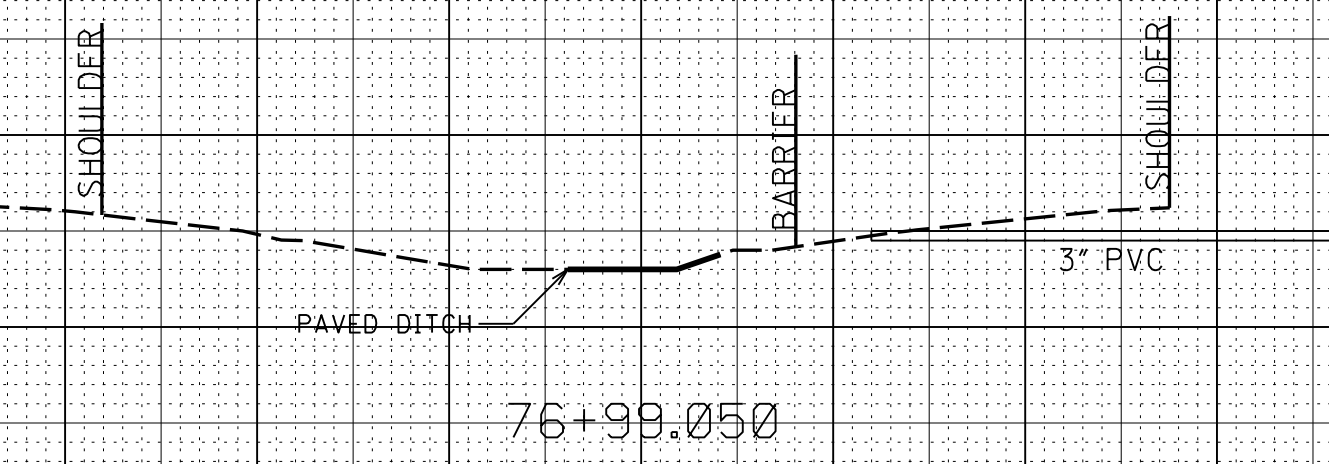
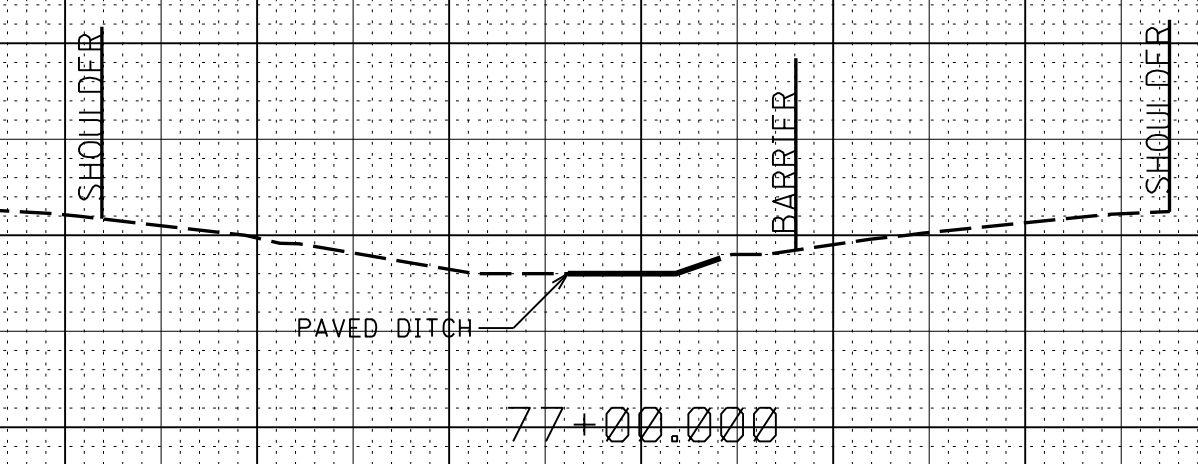
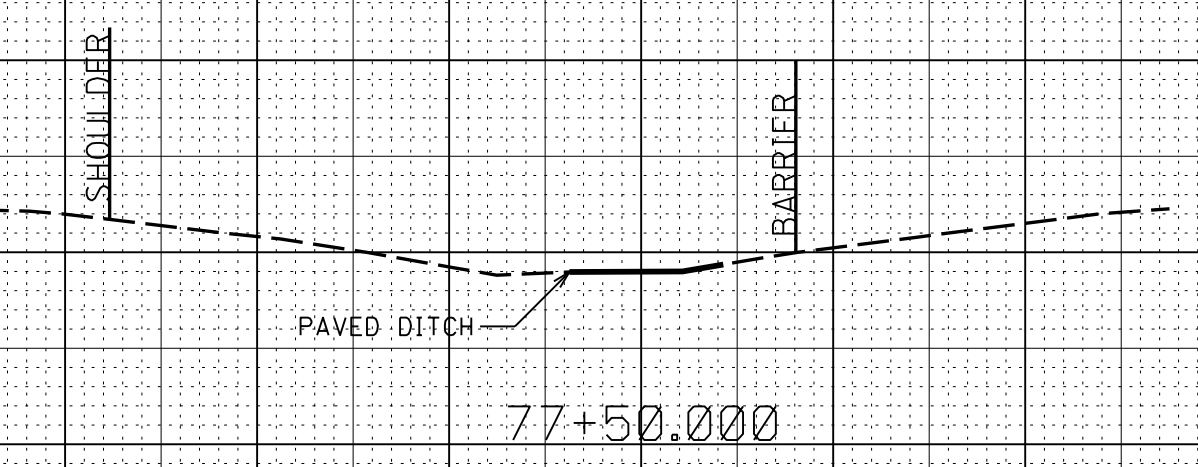

80 60 40 20 74+00.000 20 40 60 80 80 60 40 20 76+00.000 20 40

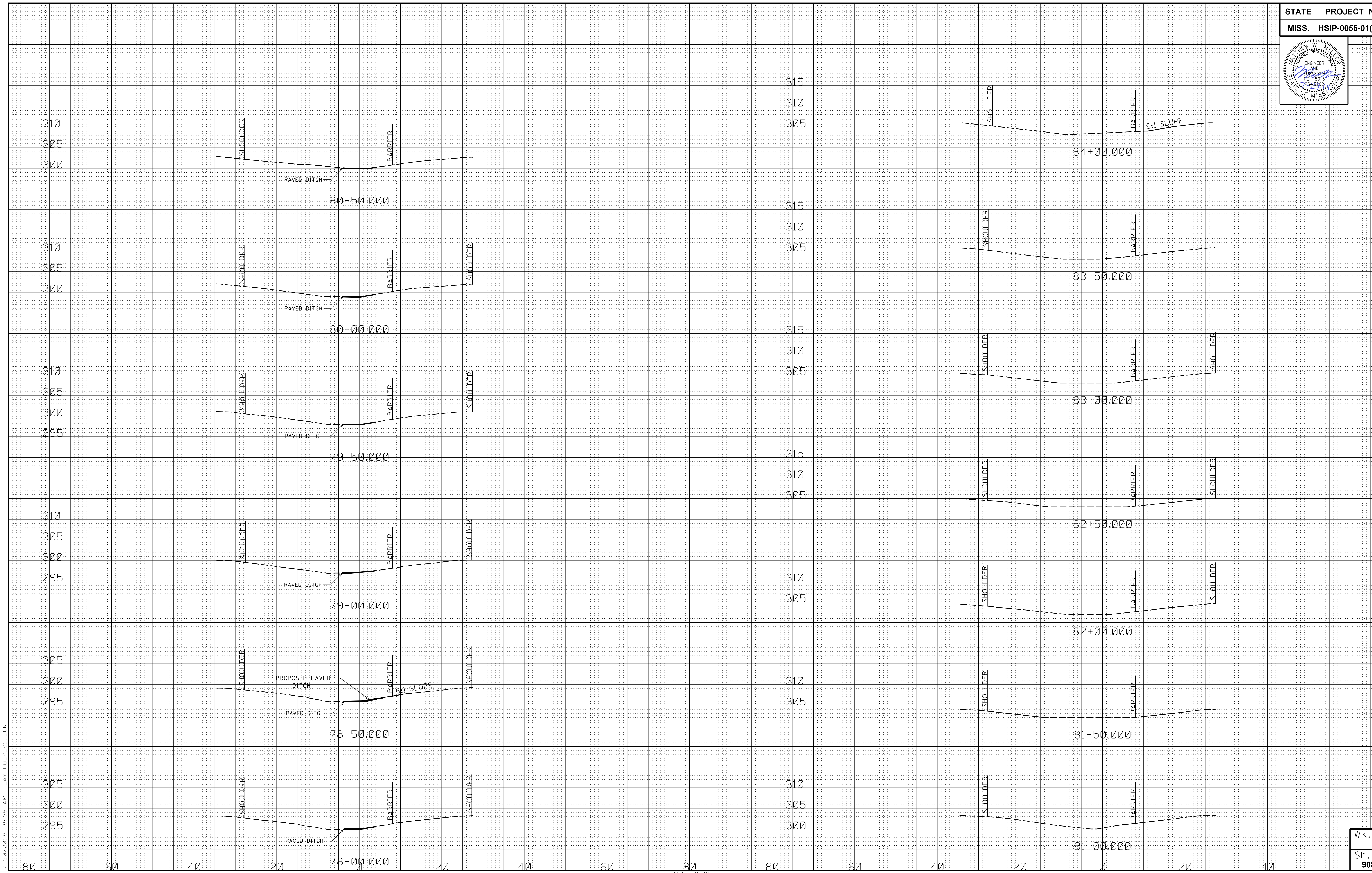
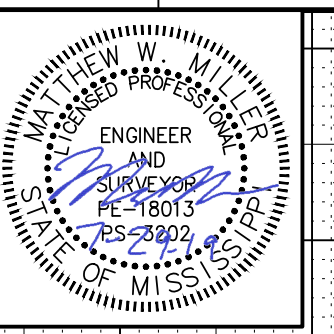

7/30/2019 8:35 AM LAY-HOLMES1.DGN

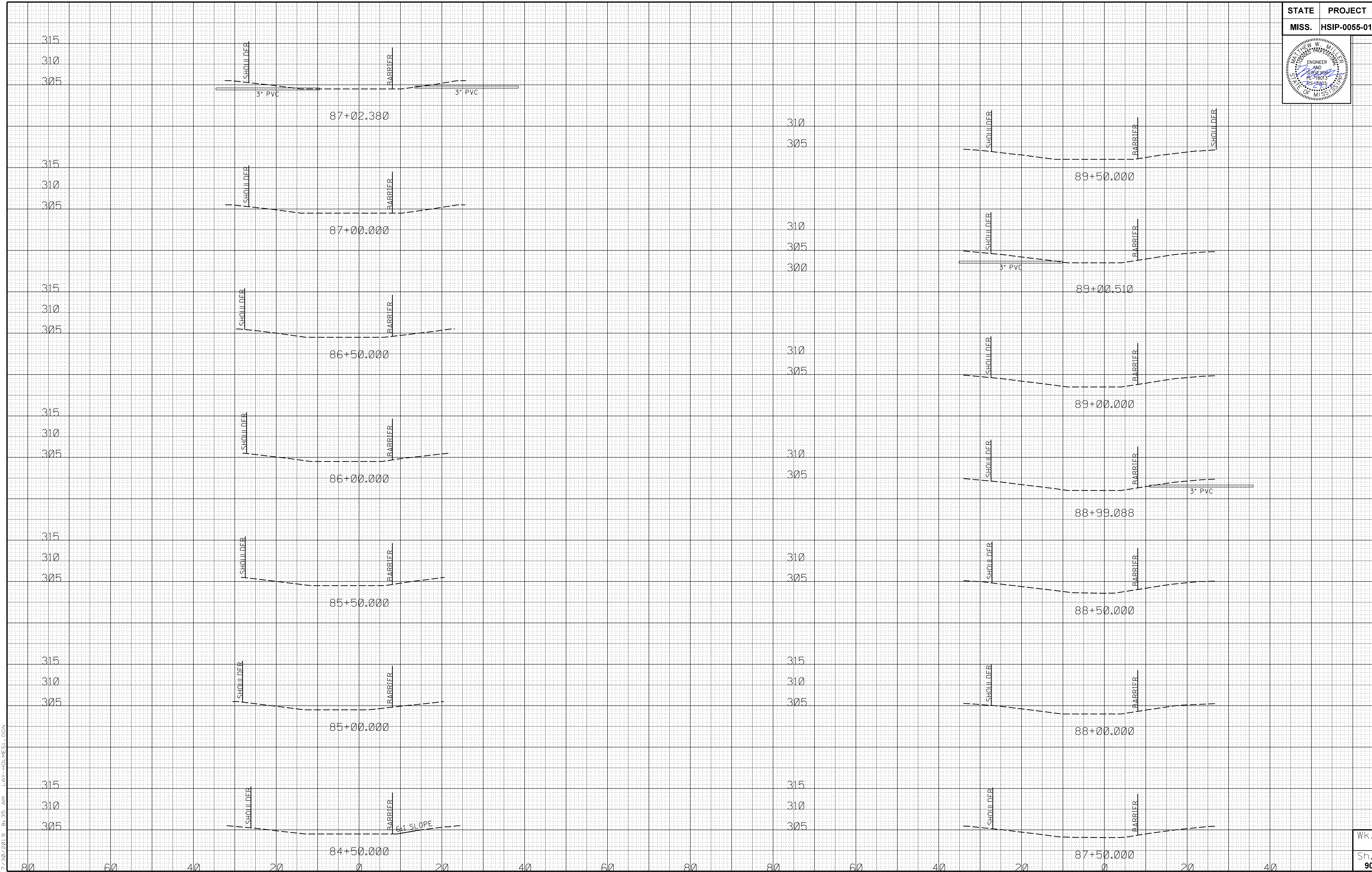
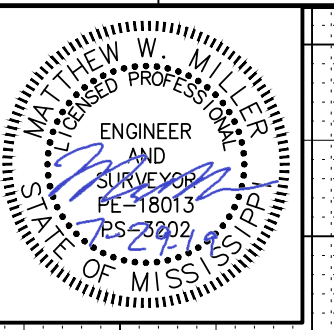

7/30/2019 8:35 AM LAY-HOLMES1.DGN

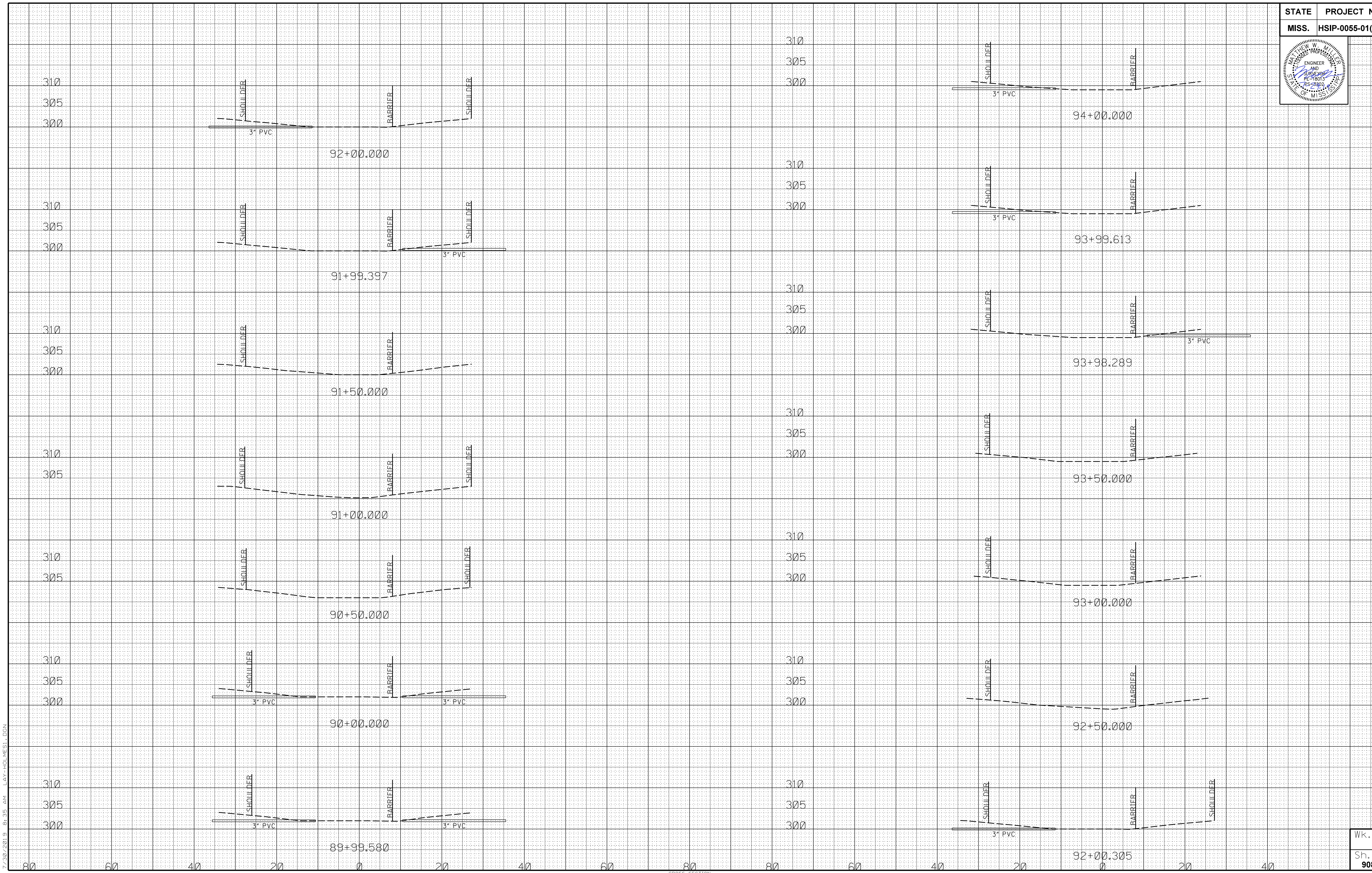
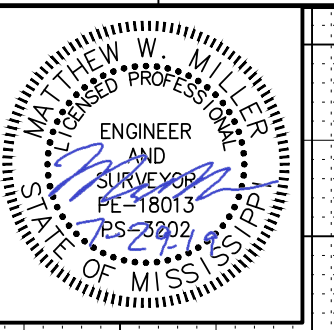

7/30/2019 8:35 AM LAY-HOLMES1.DGN

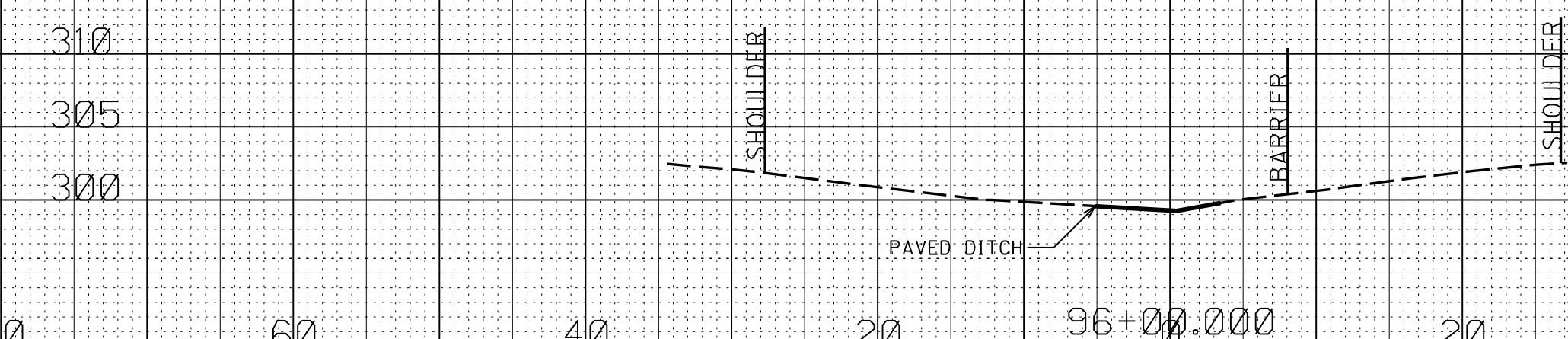
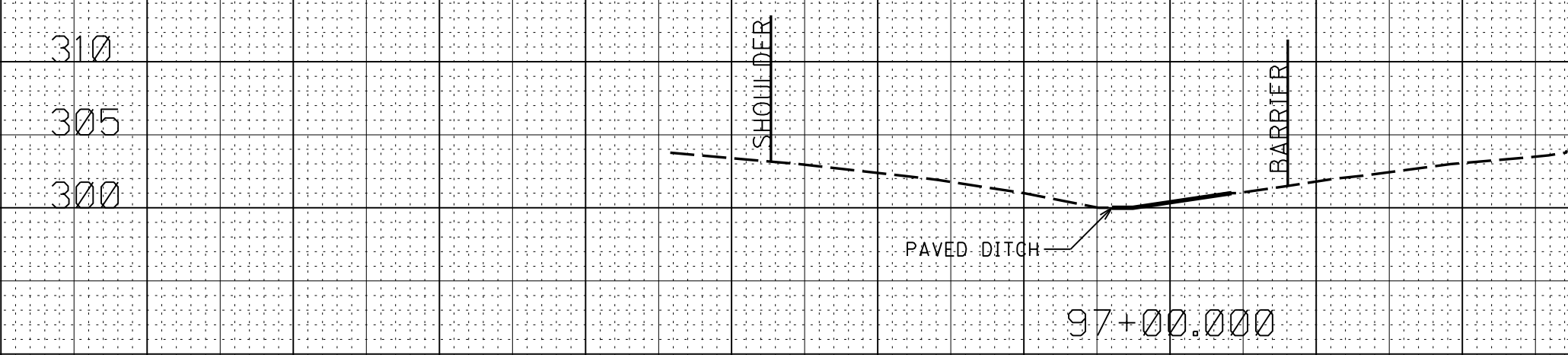
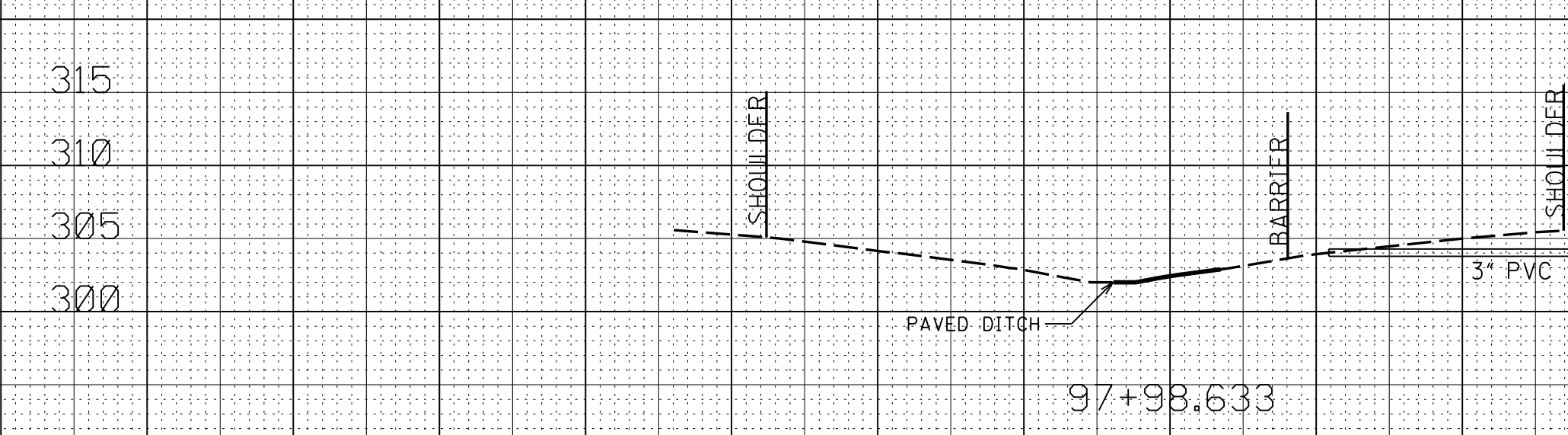
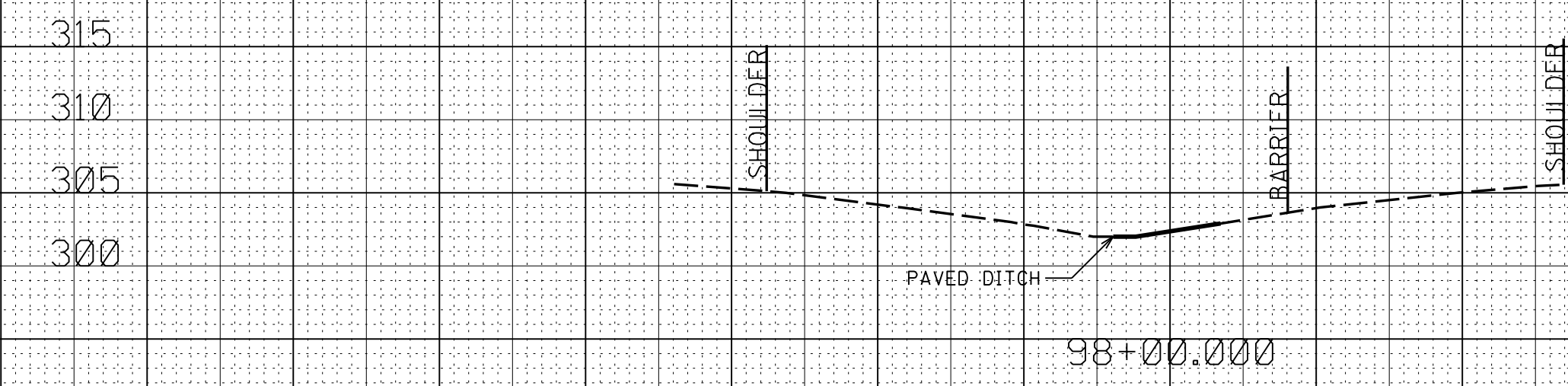
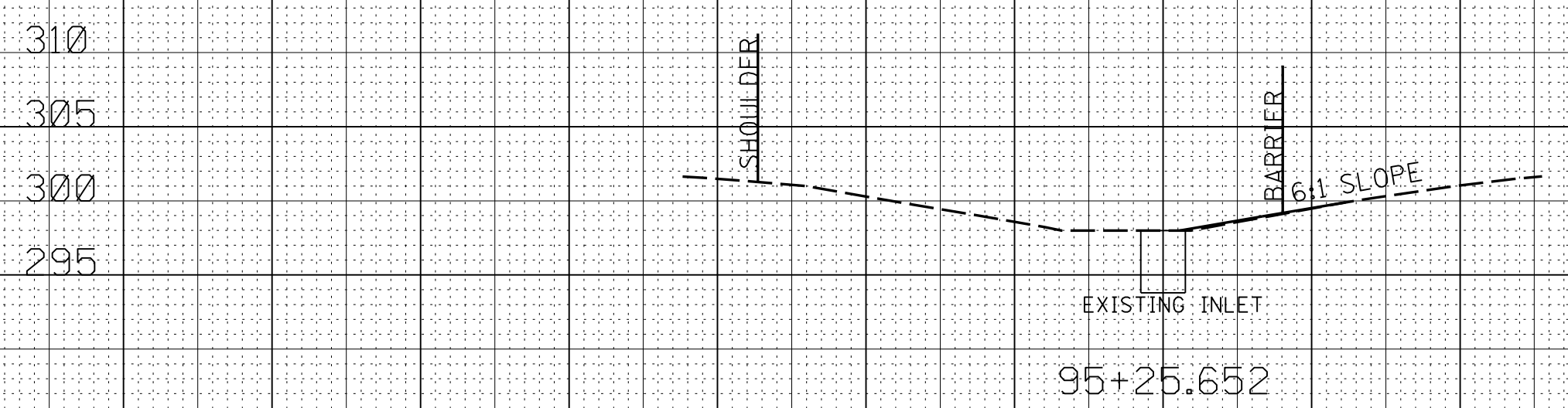
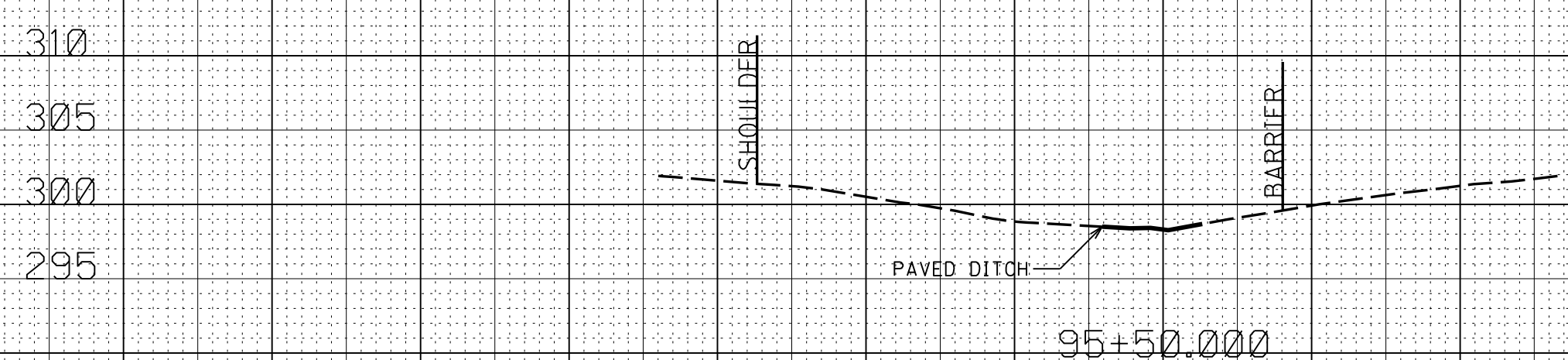
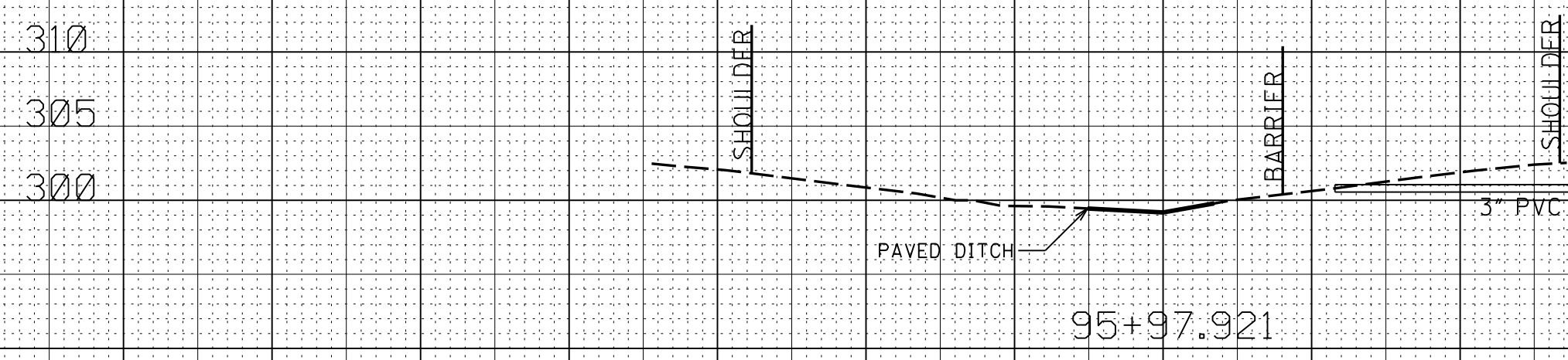
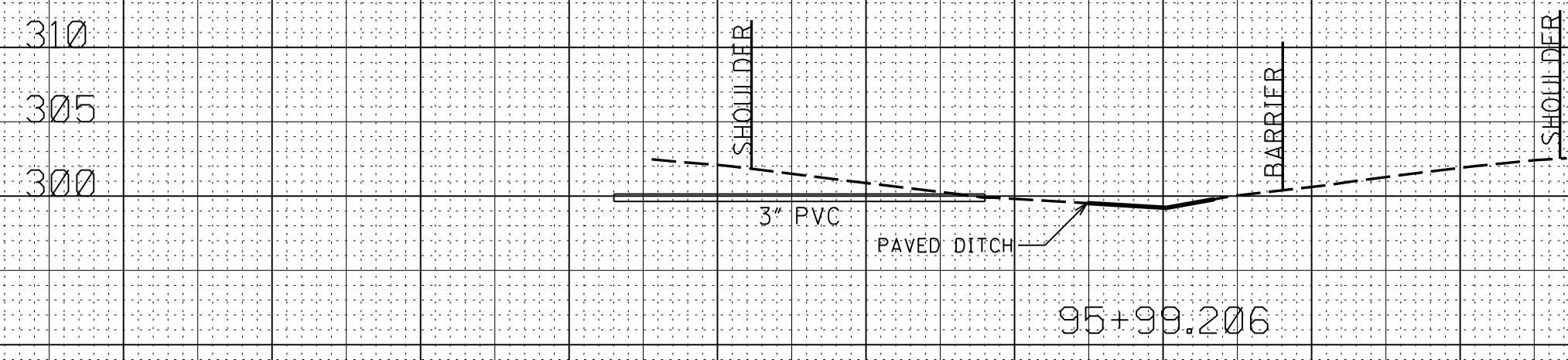
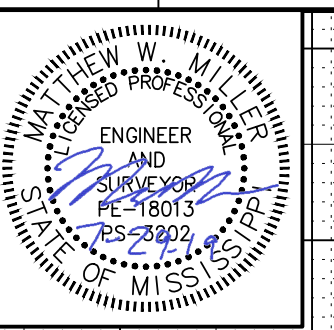

7/30/2019 8:35 AM LAY-HOLMES1.DGN

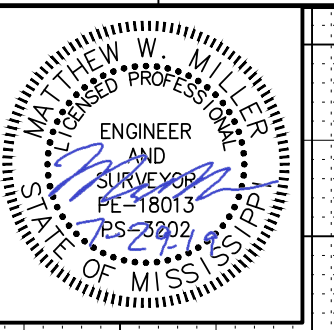

315
310
315
310
315
310
305
315
310
305
315
310
305
315
310
300

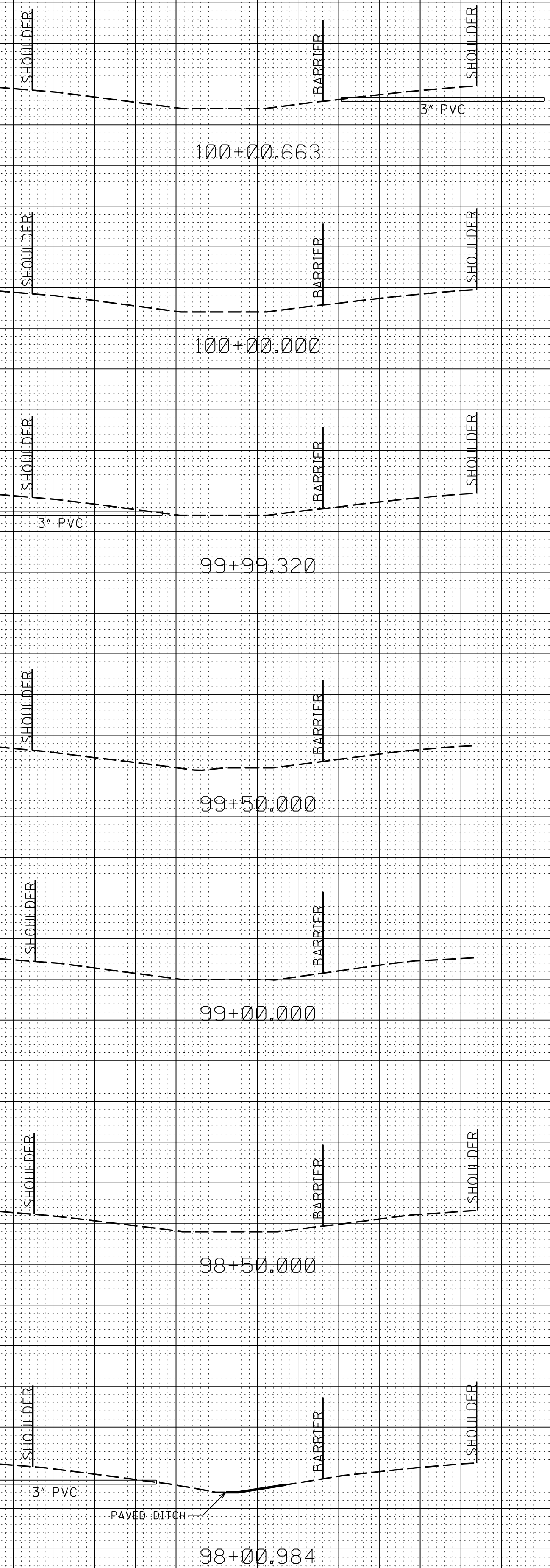

320
315
320
315
320
315
310
320
315
310
320
315
310
320
315
310

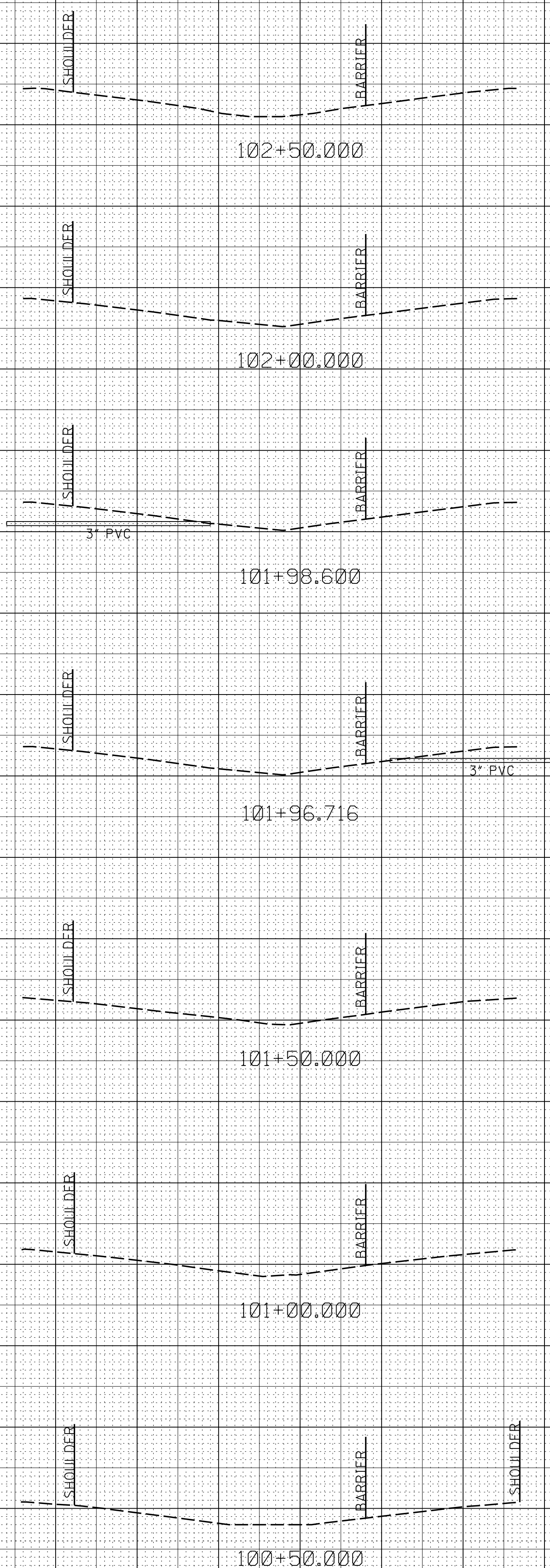

7/30/2019 8:35 AM LAY-HOLMES1.DGN

80 60 40 20 0 20 40 60 80 80 60 40 20 0 20 40

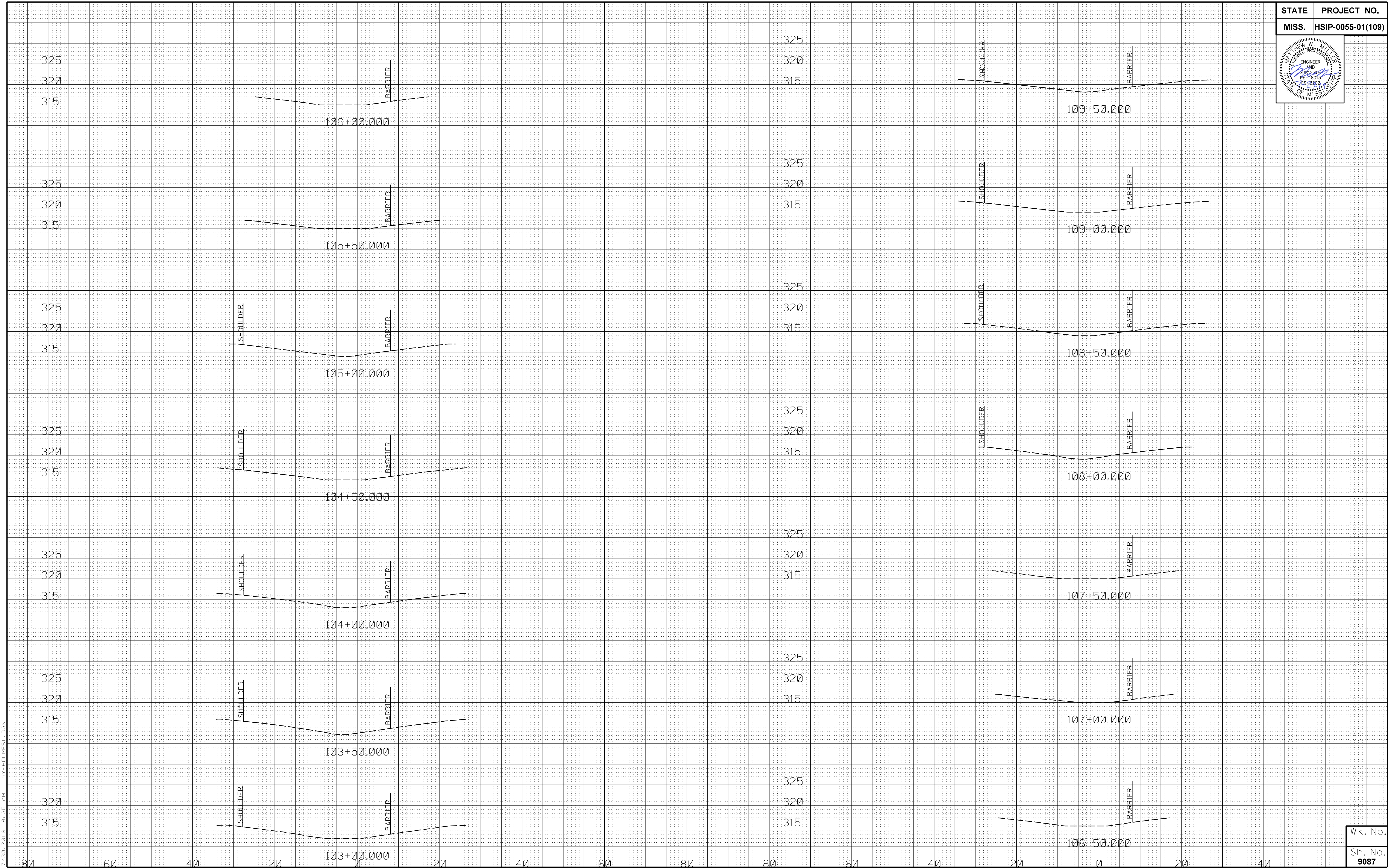
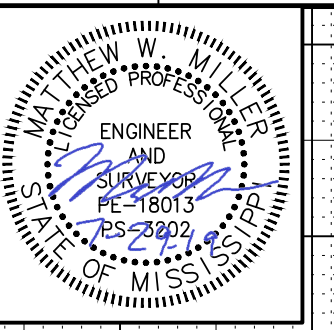

7/30/2019 8:35 AM LAY-HOLMES1.DGN

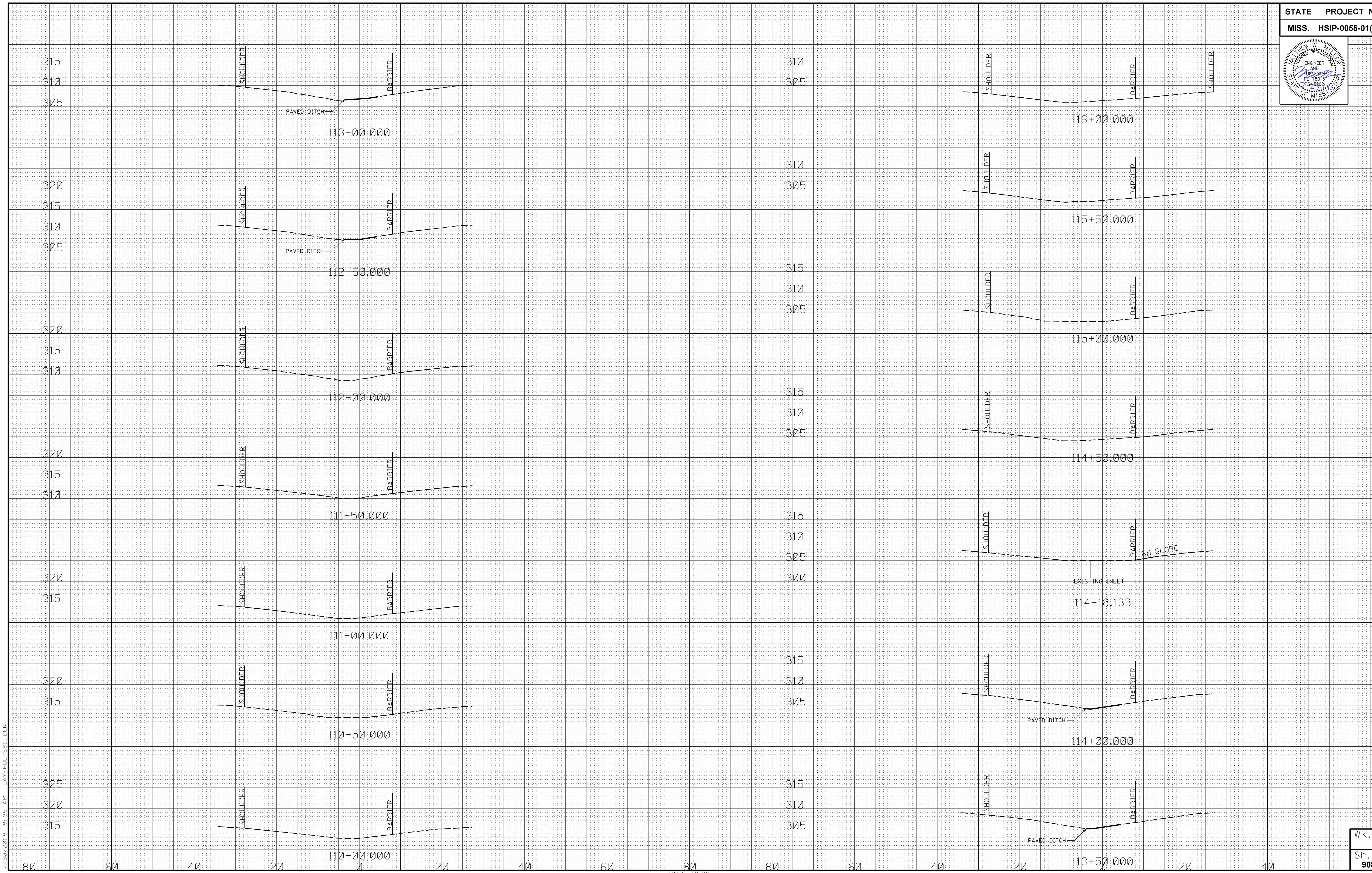
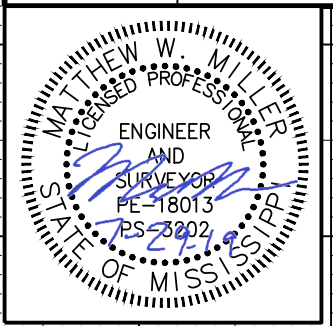

7/30/2019 8:35 AM LAY-HOLMES1.DGN

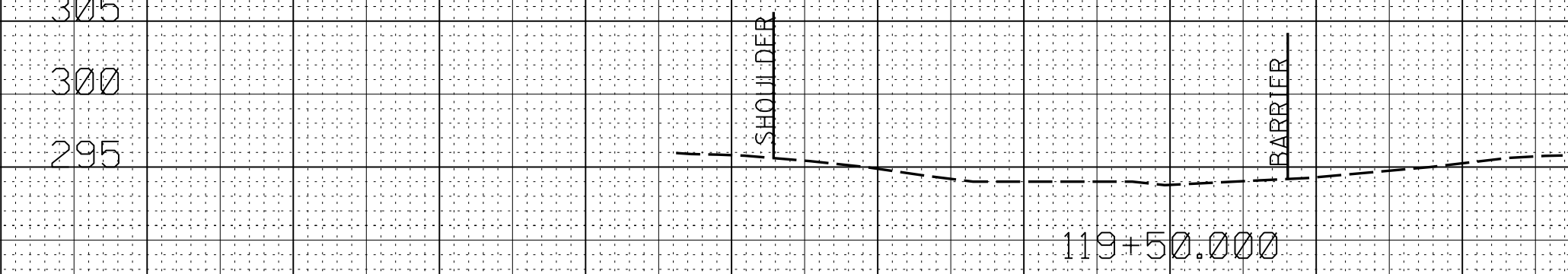
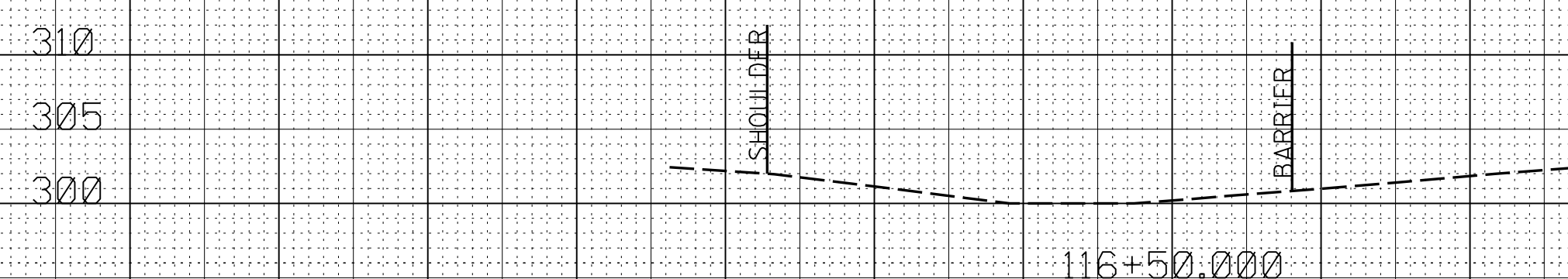
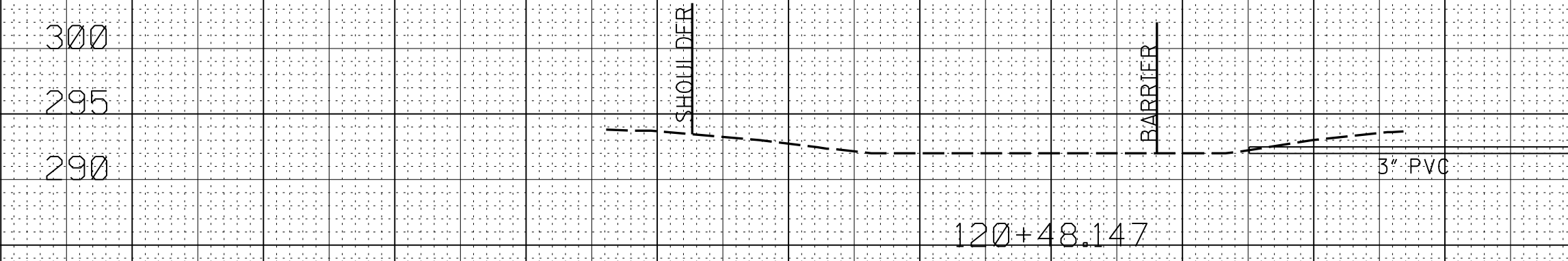
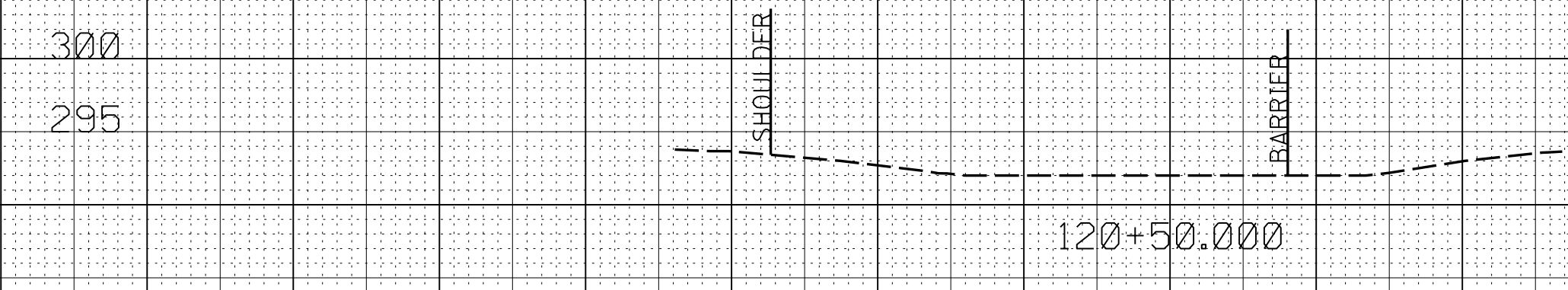
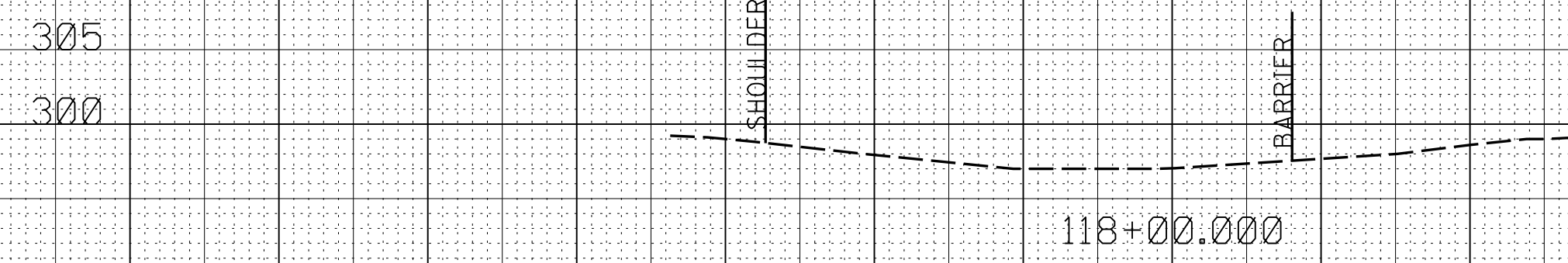
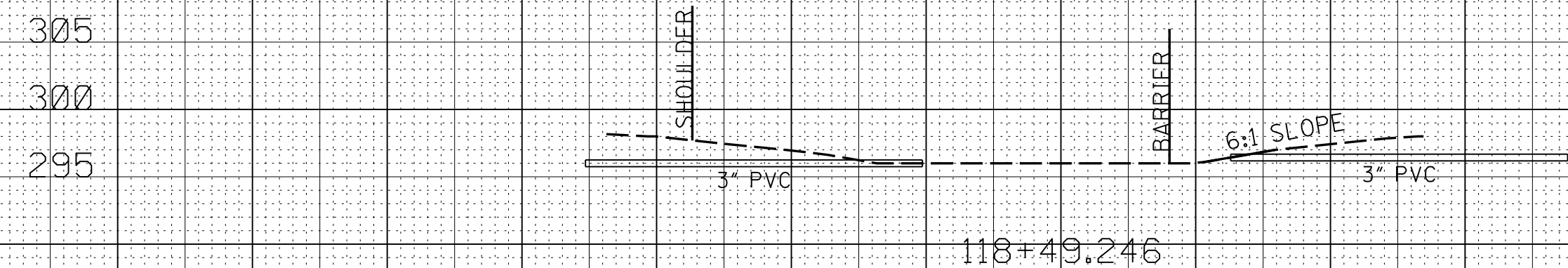
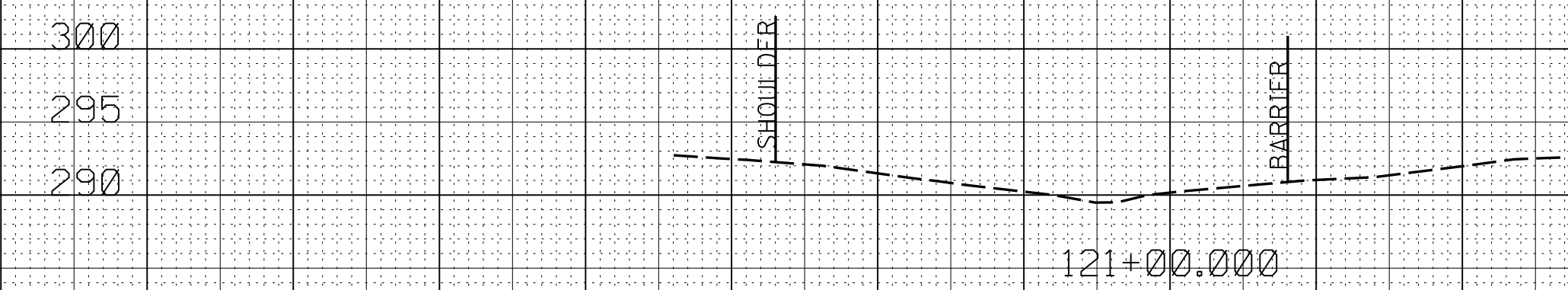
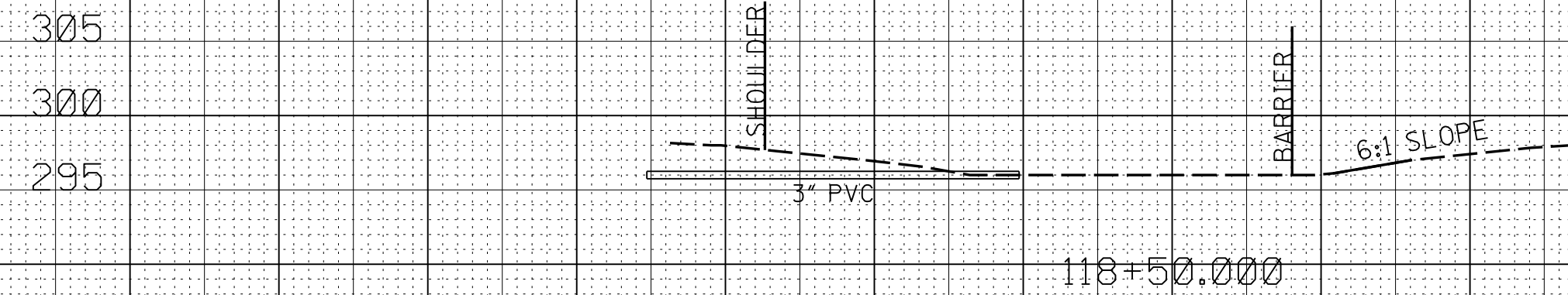
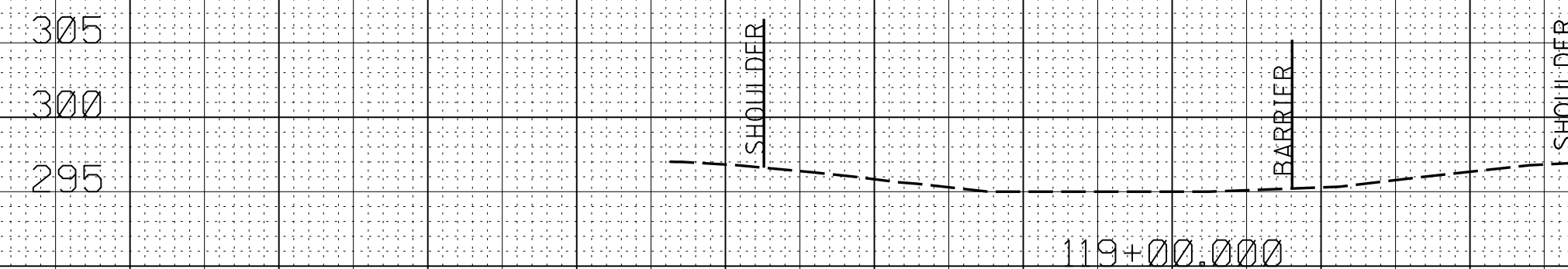
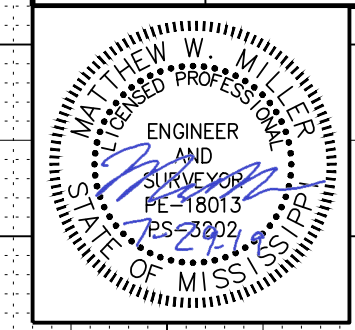

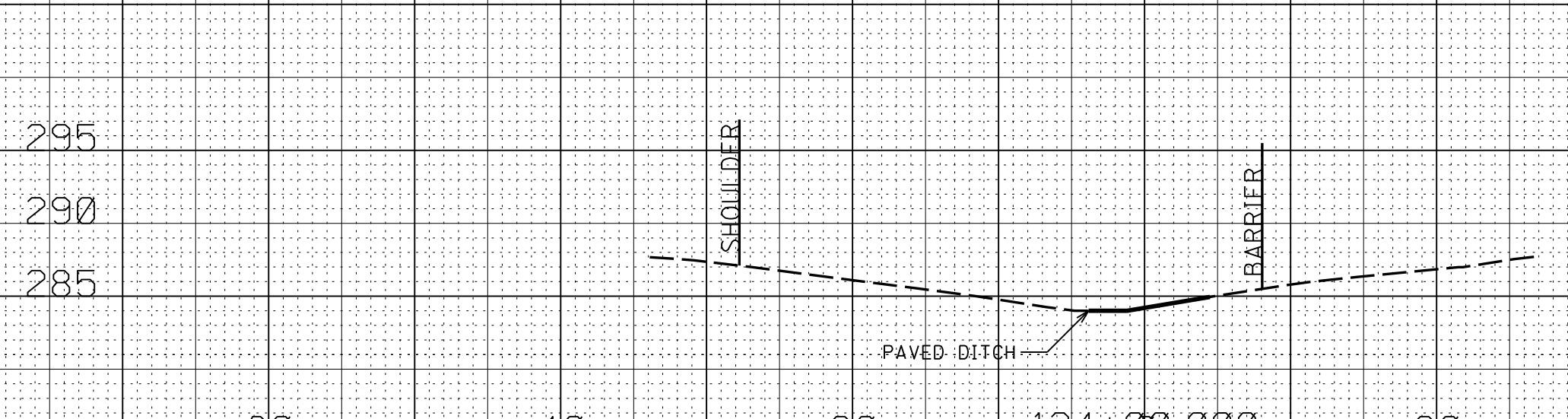
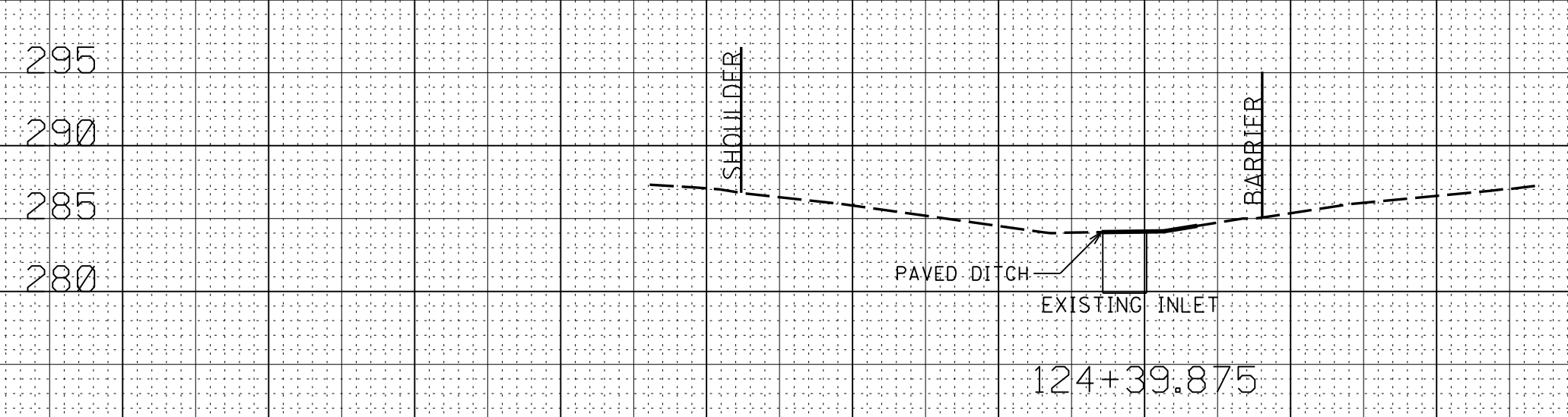
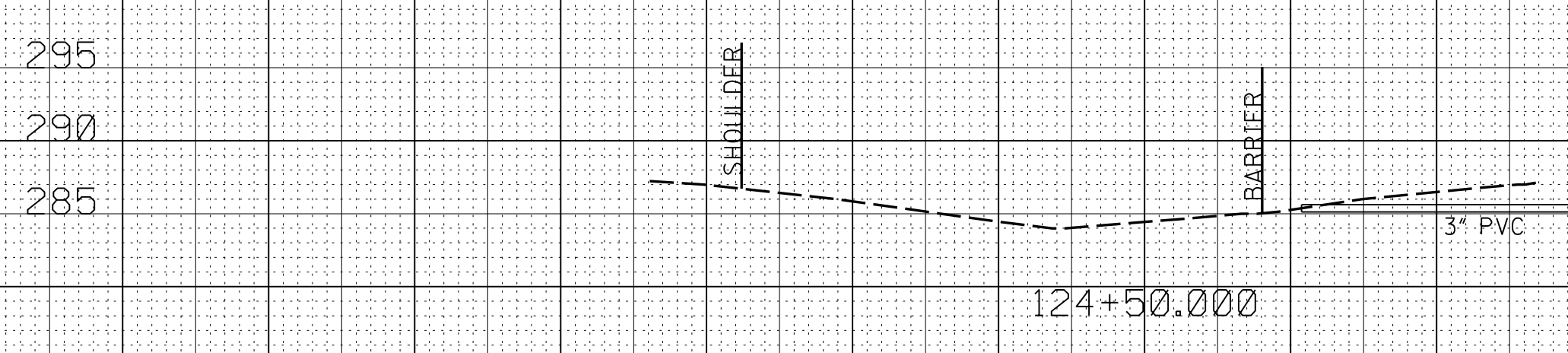
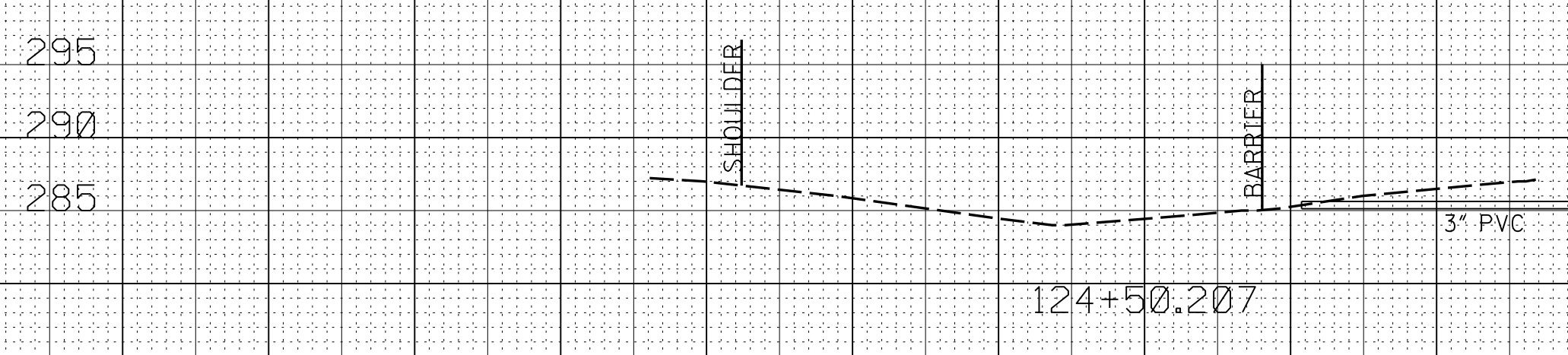
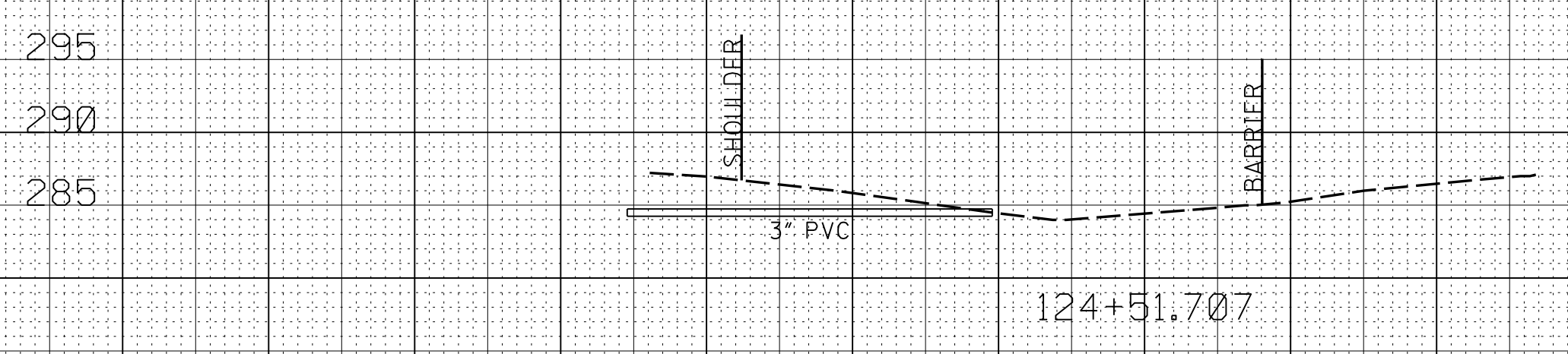
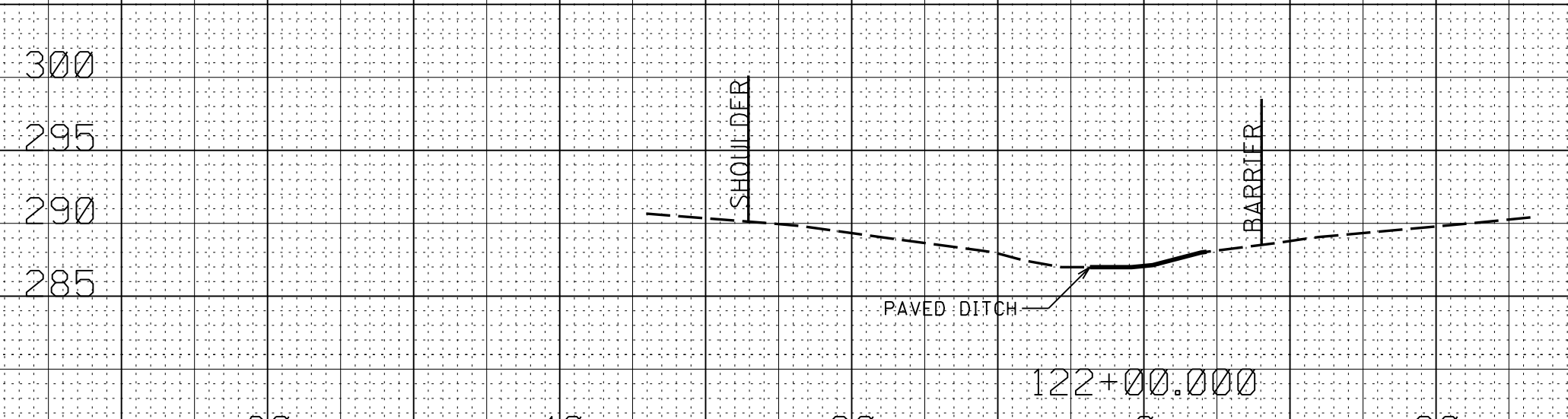
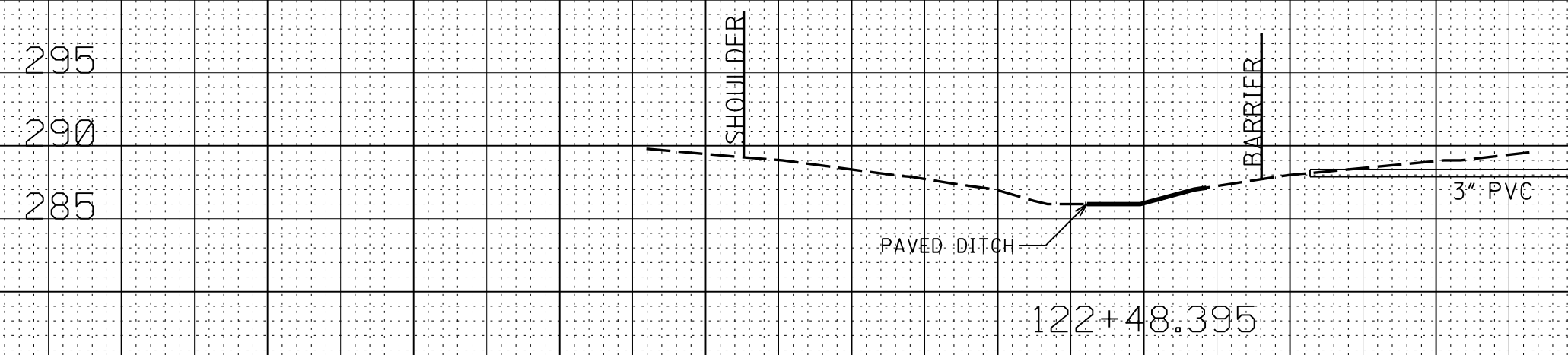
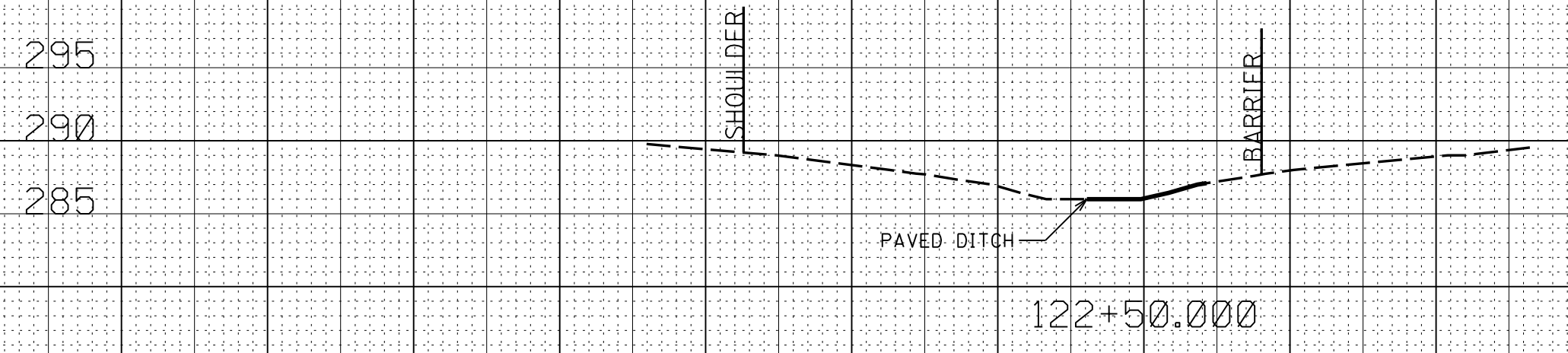
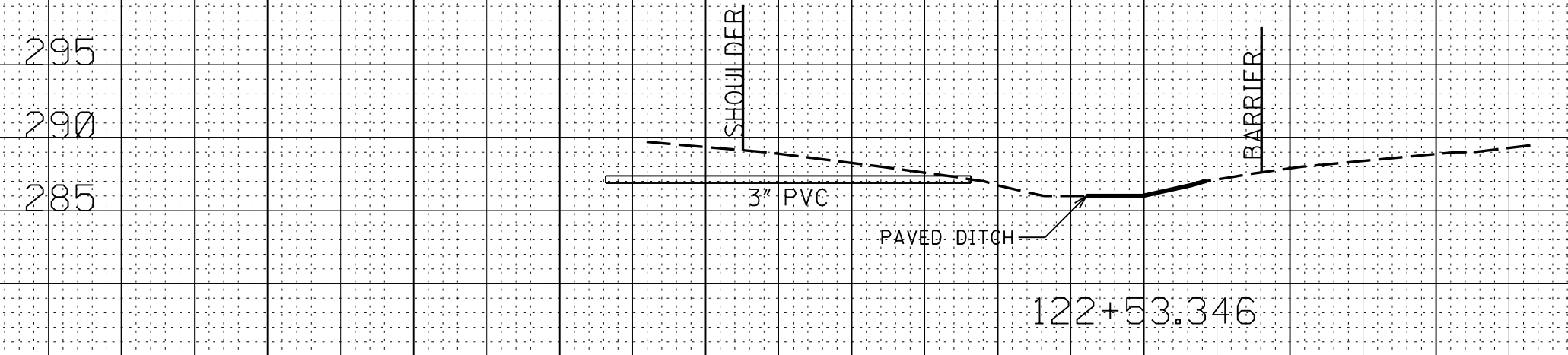
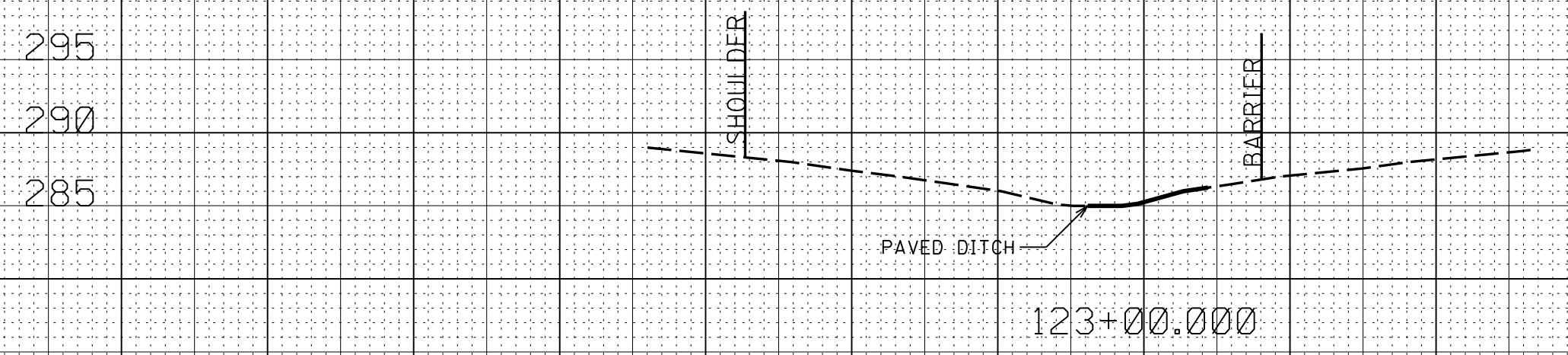
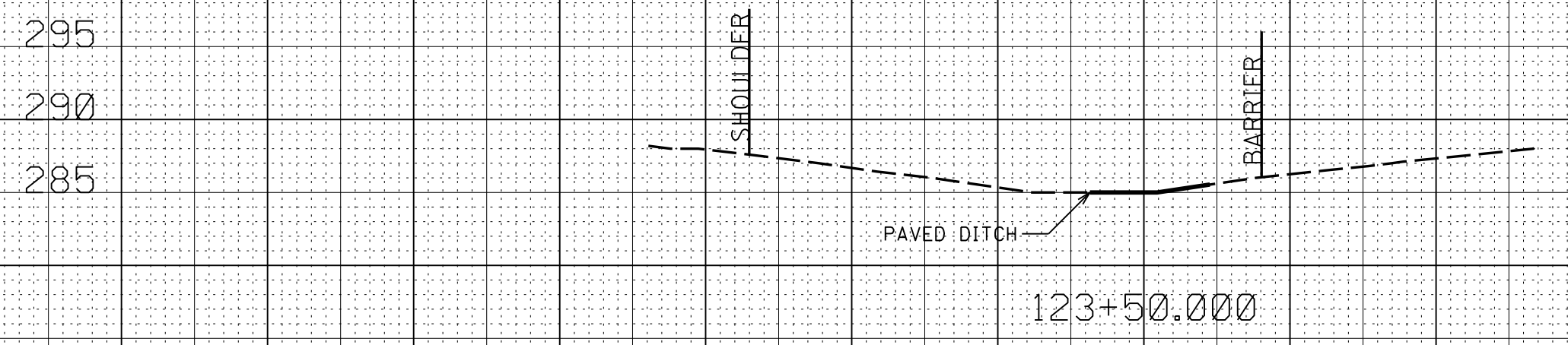
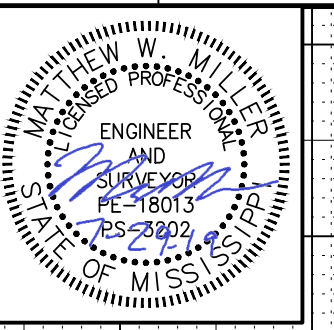

7/30/2019 8:35 AM LAY-HOLMES1.DGN

80 60 40 20 0 20 40 60 80 80 60 40 20 124+00.000 20 40

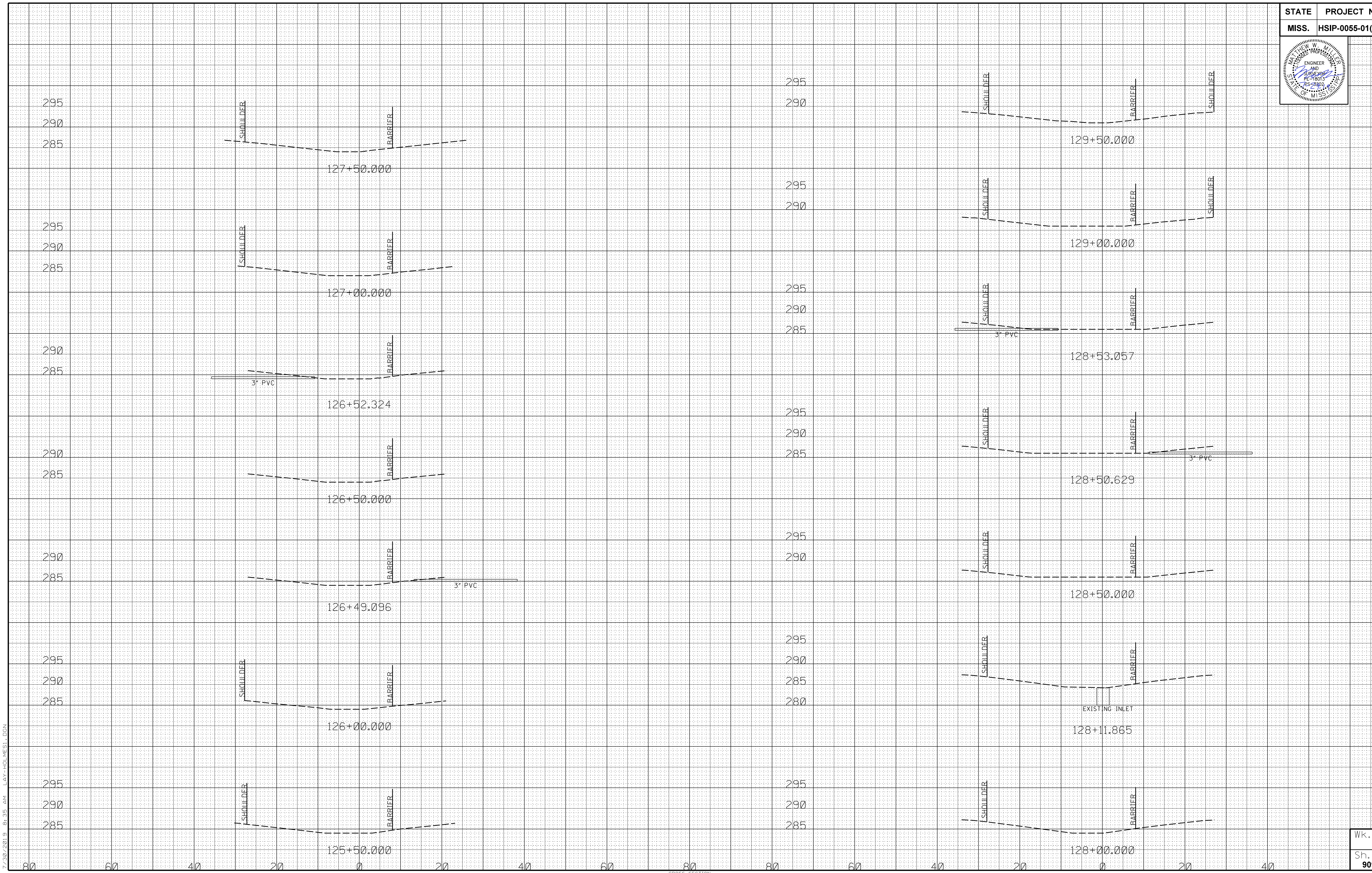
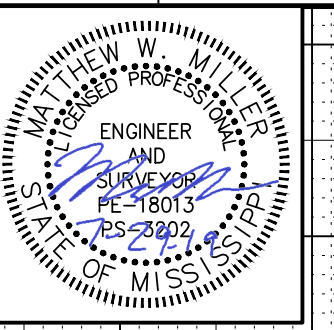

7/30/2019 8:35 AM LAY-HOLMES1.DGN

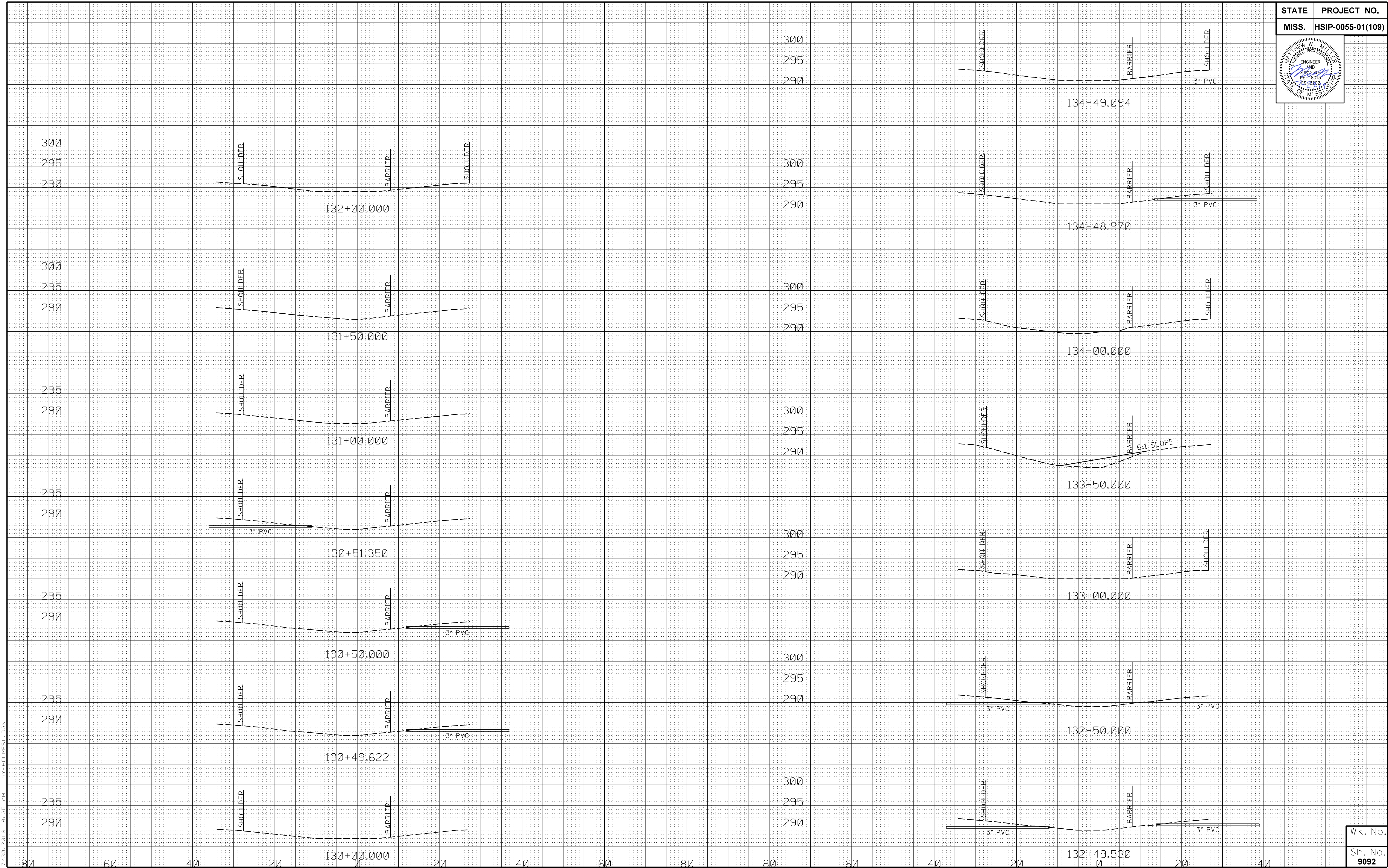
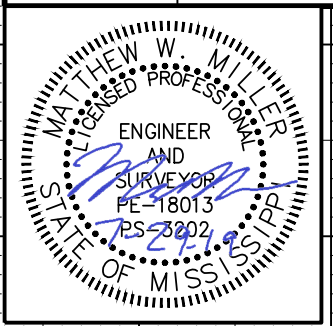

7/30/2019 8:35 AM LAY-HOLMES1.DGN

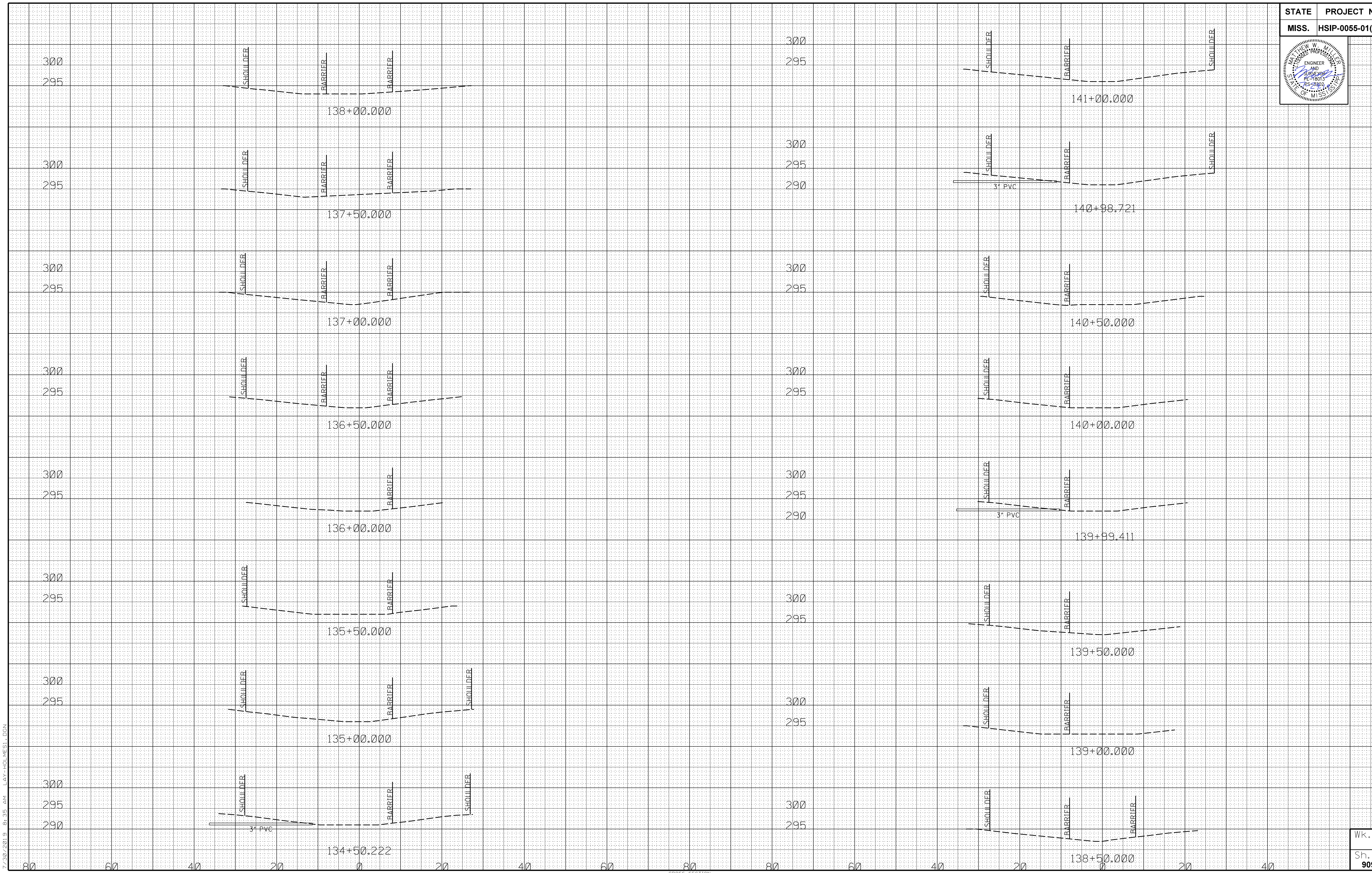
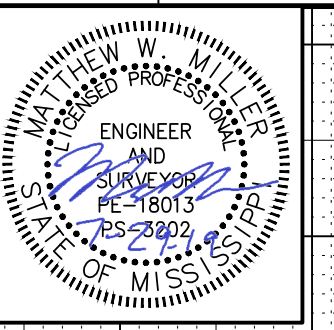

7/30/2019 8:35 AM LAY-HOLMES1.DGN

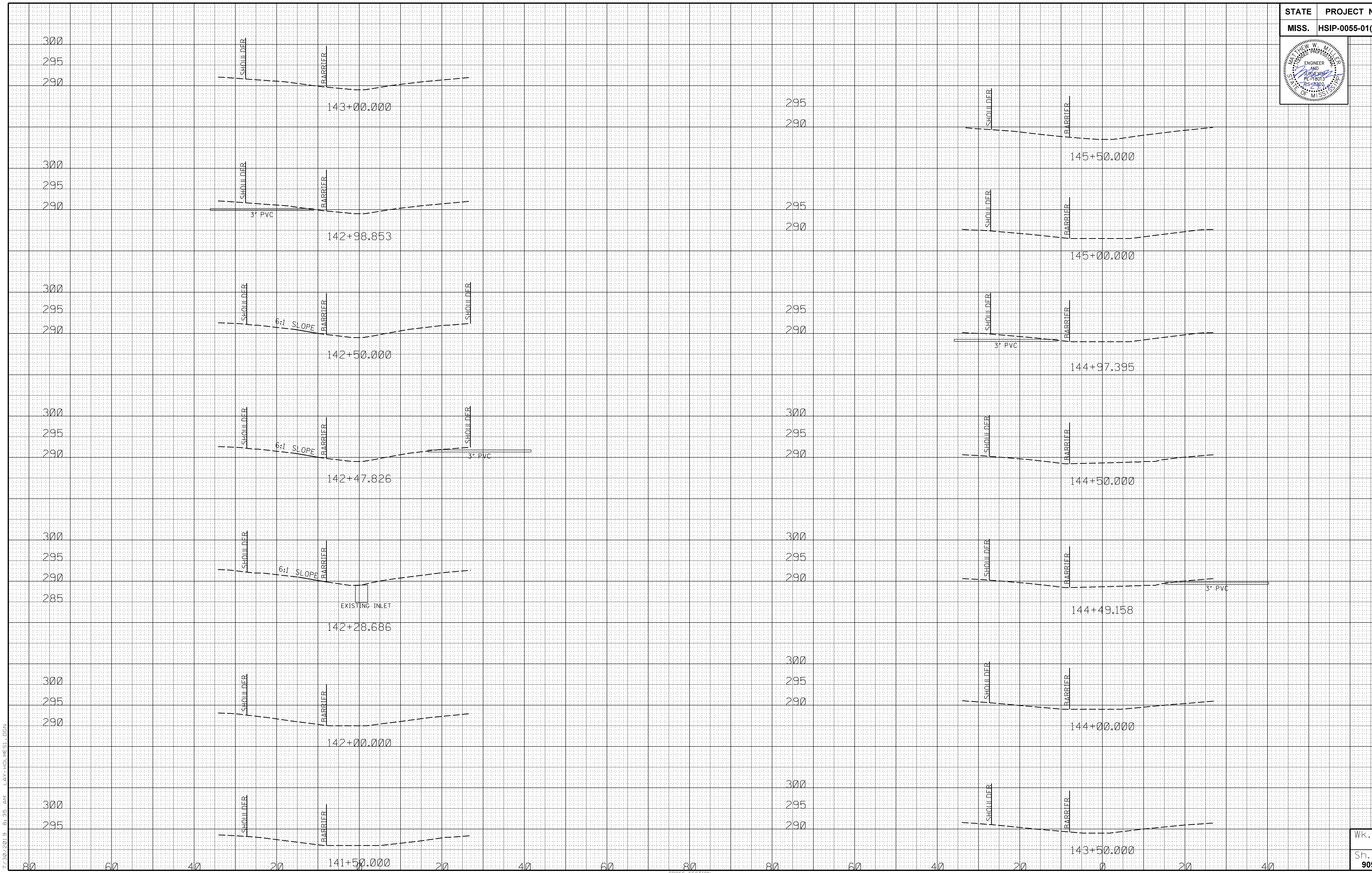
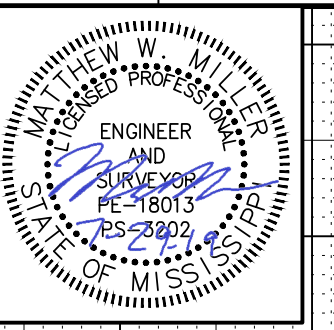

7/30/2019 8:35 AM LAY-HOLMES1.DGN

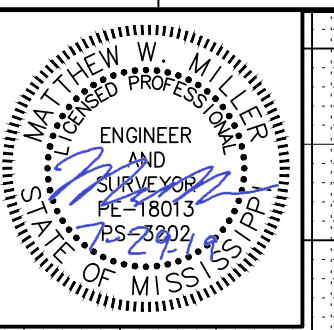

295
290
285
295
290
295
290
295
290
295
290
285
295
290
295
290
295
290
295
290

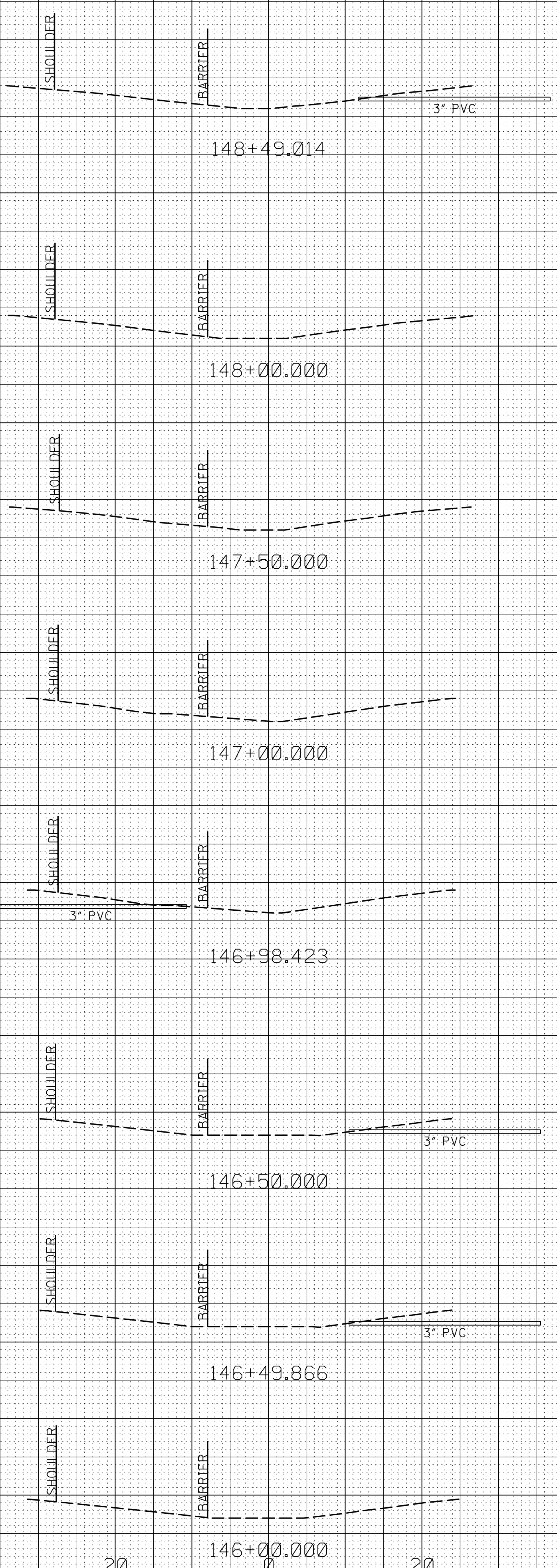

295
290
285
295
290
285
295
290
295
290
295
290
295
290
295
290
295
290
295
290

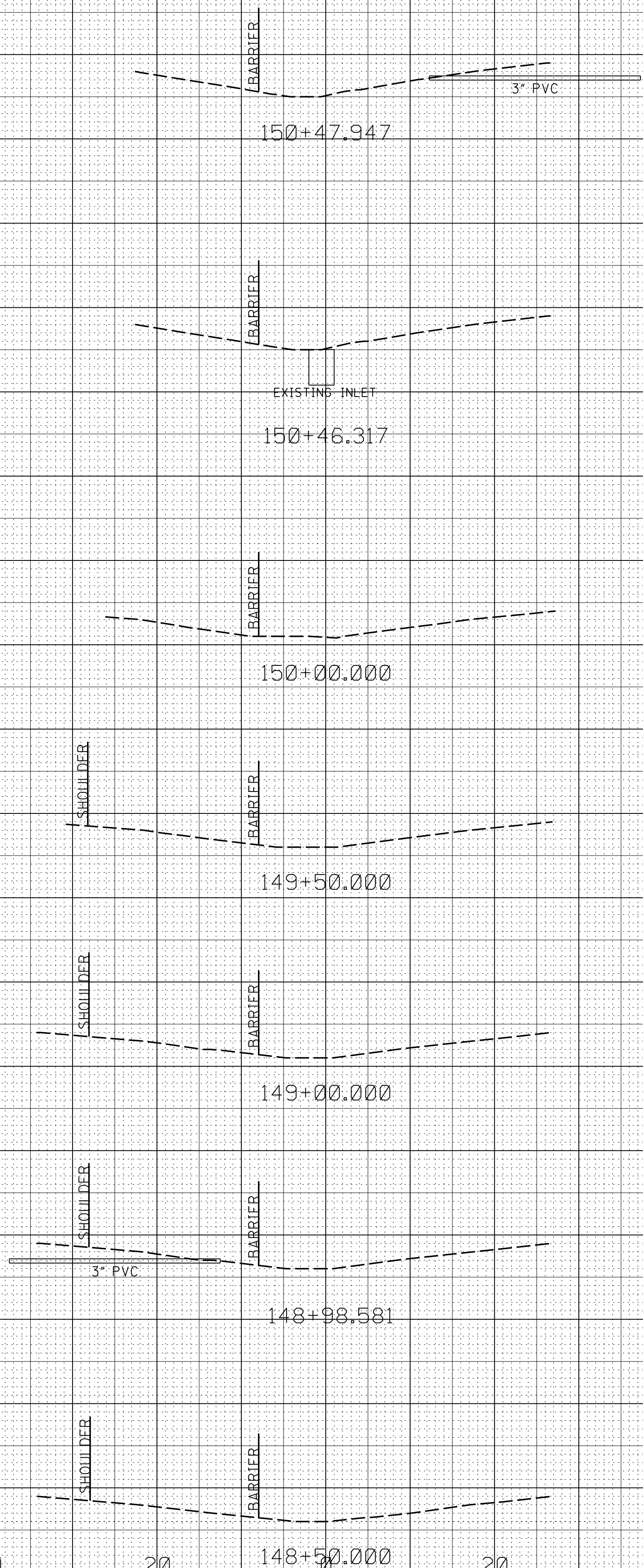

7/30/2019 8:35 AM LAY-HOLMES1.DGN

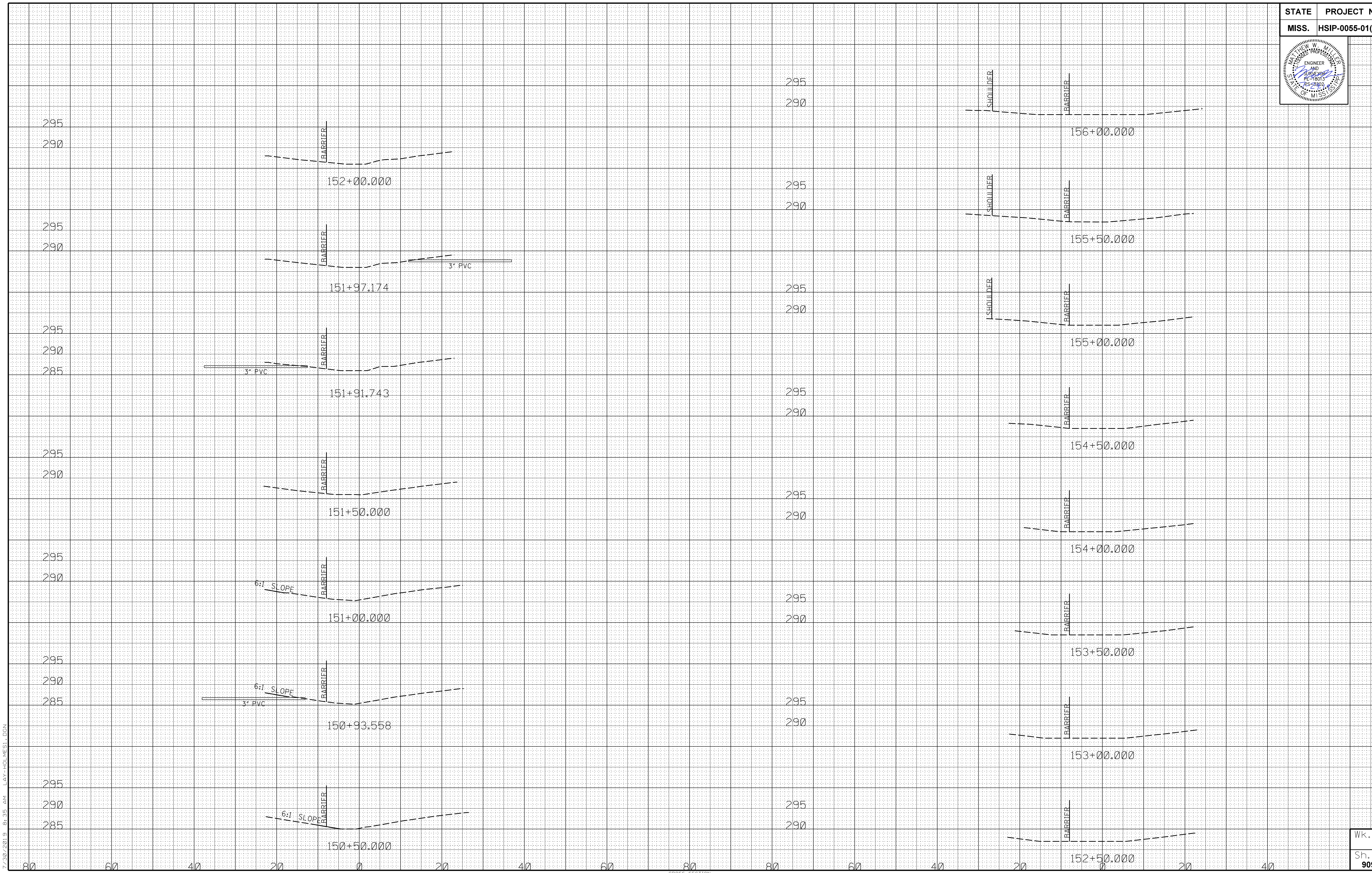
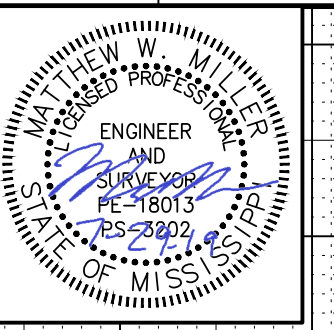

7/30/2019 8:35 AM LAY-HOLMES1.DGN

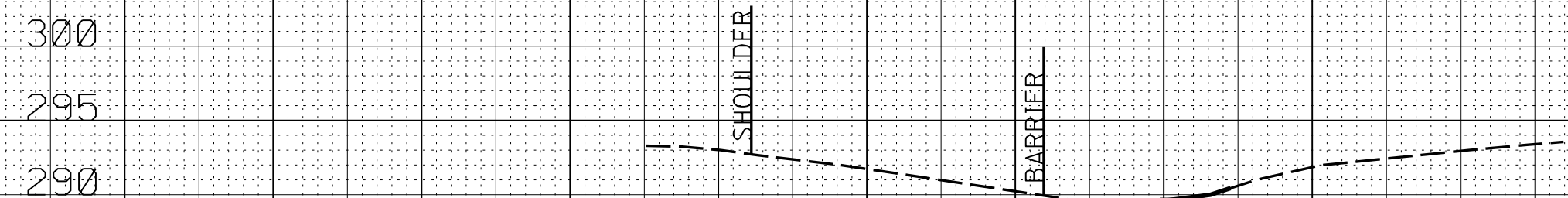
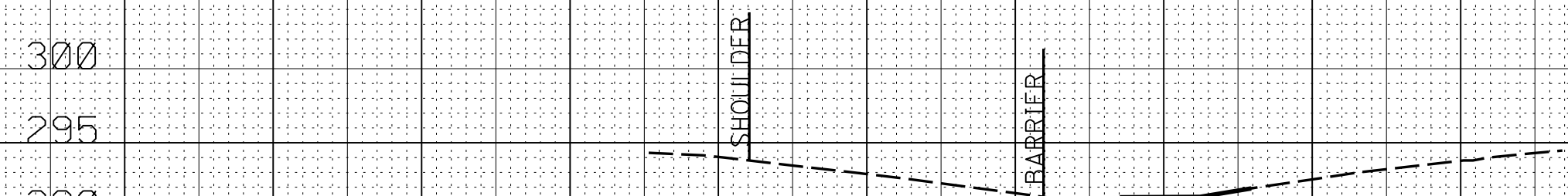
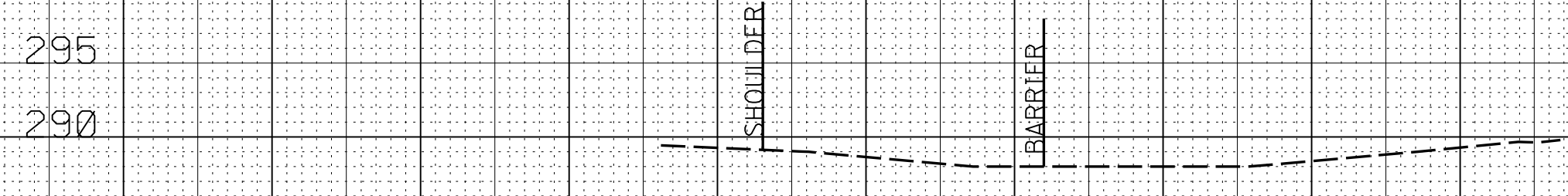
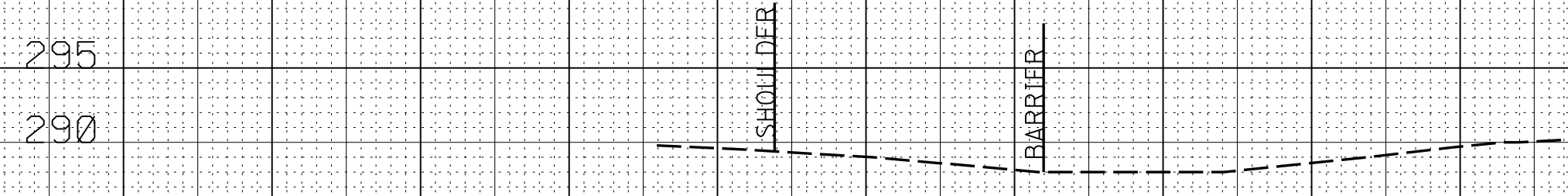
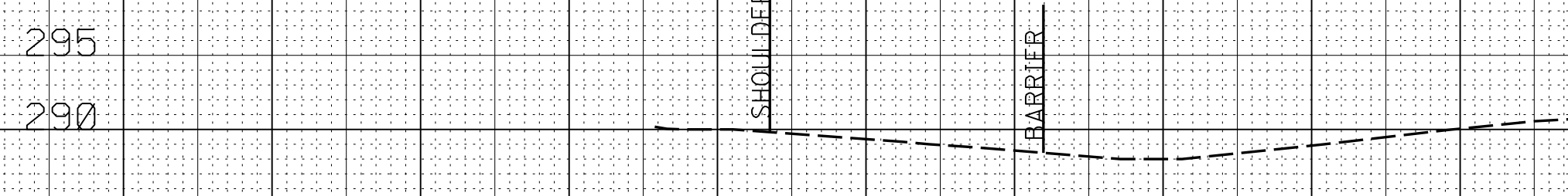
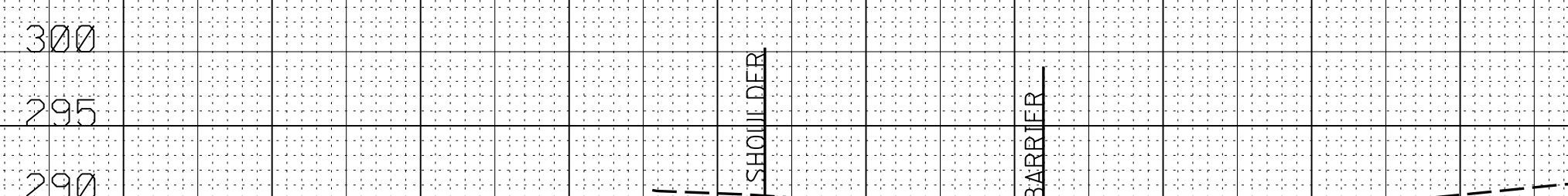
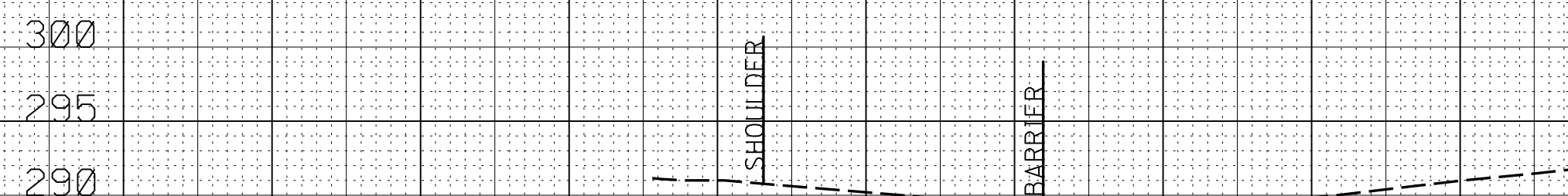
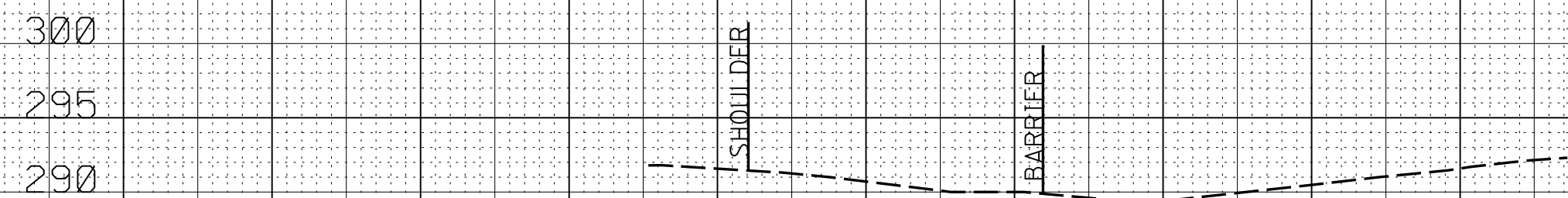
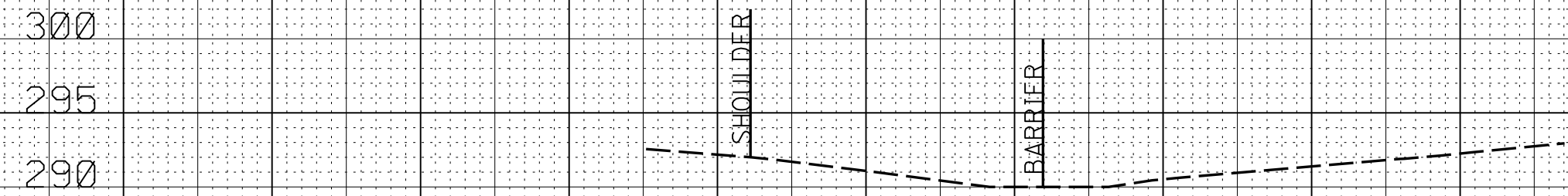
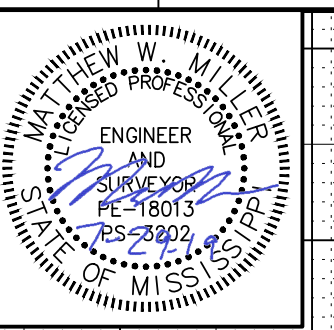

7/30/2019 8:35 AM LAY-HOLMES1.DGN

80 60 40 20 0 20 40 60 80 80 60 40 20 0 20 40

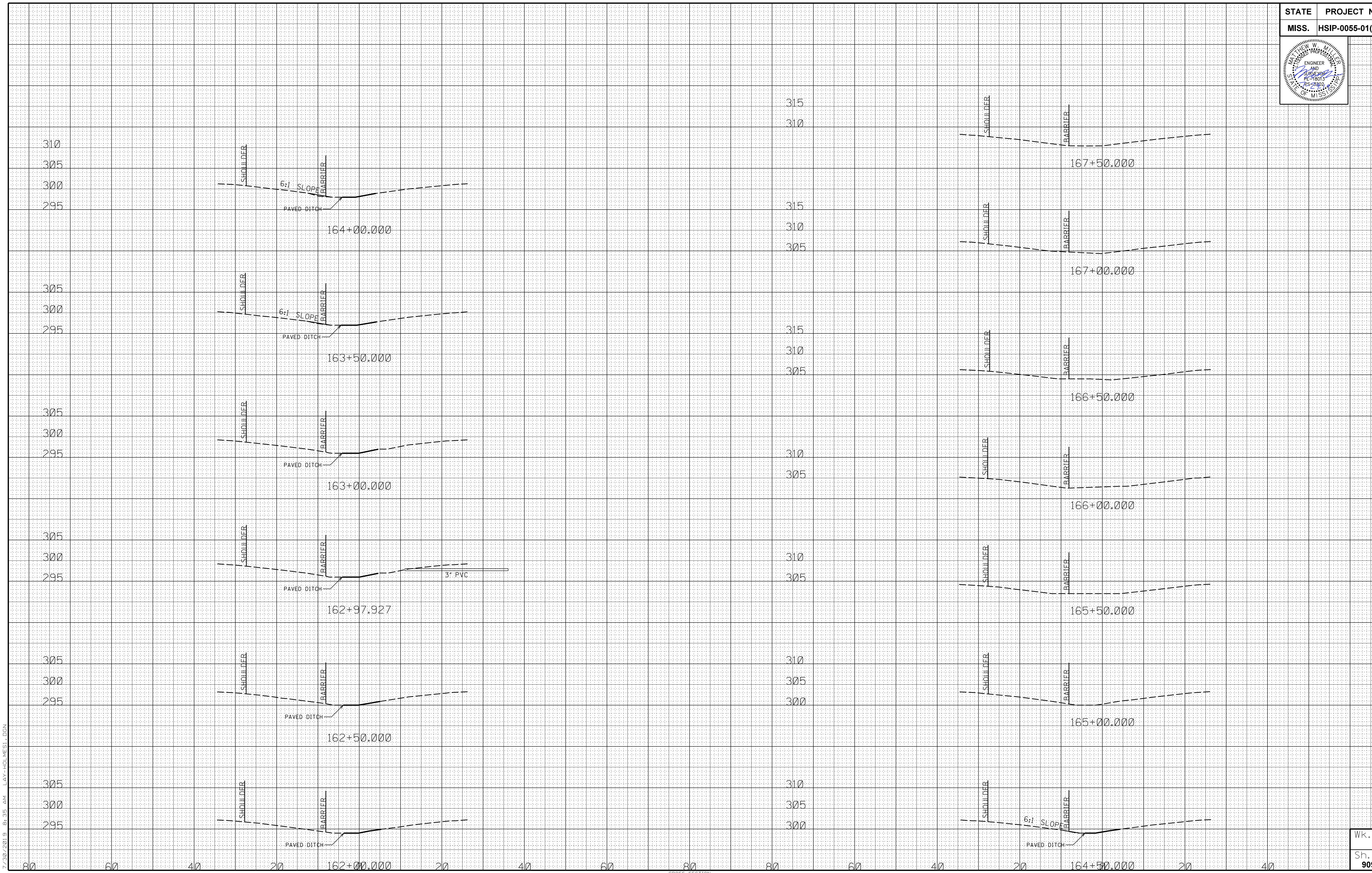
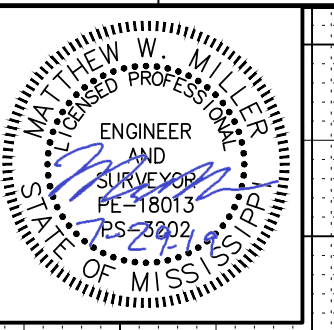

7/30/2019 8:35 AM LAY-HOLMESI.DGN

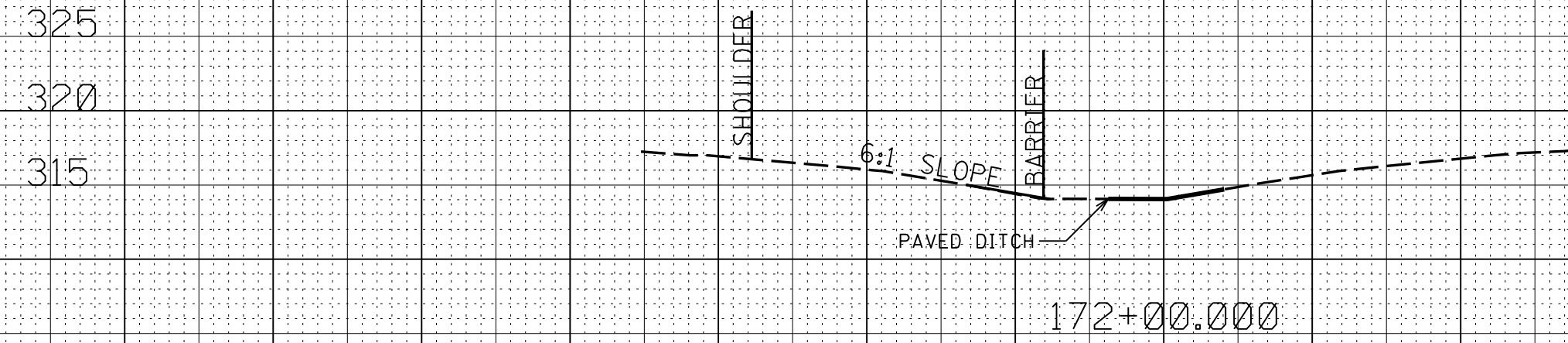
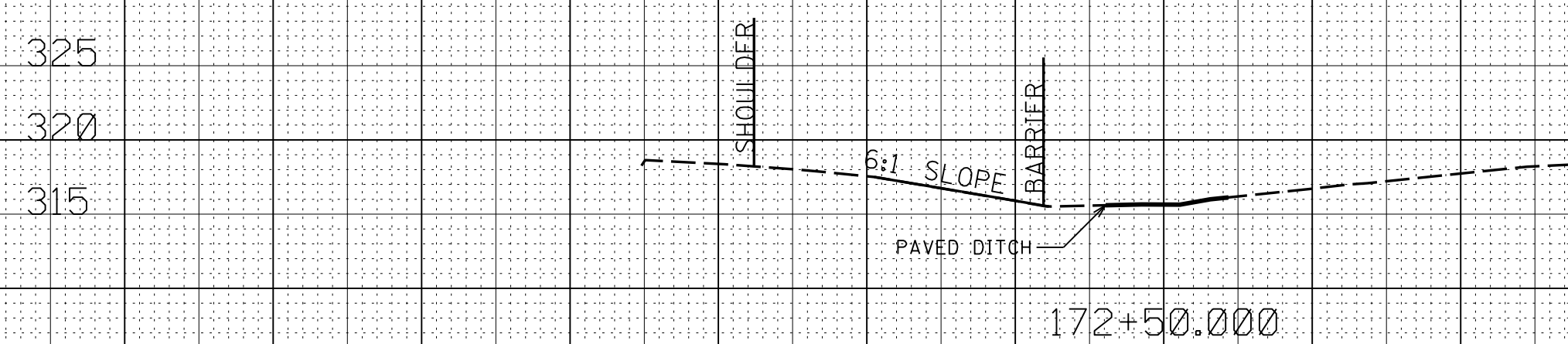
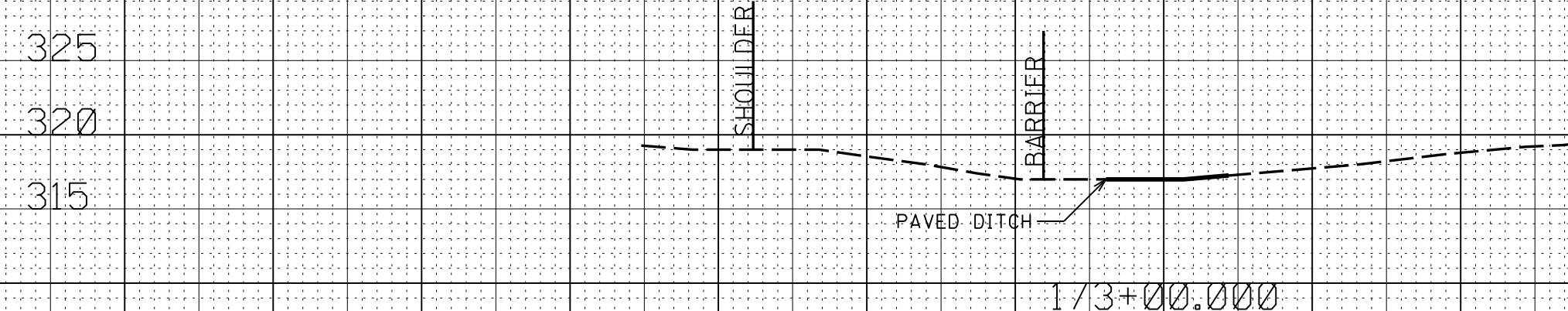
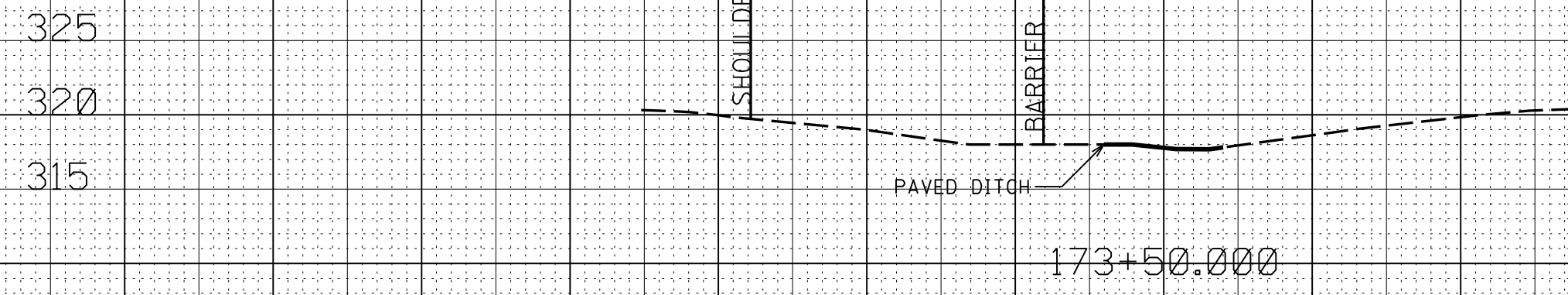
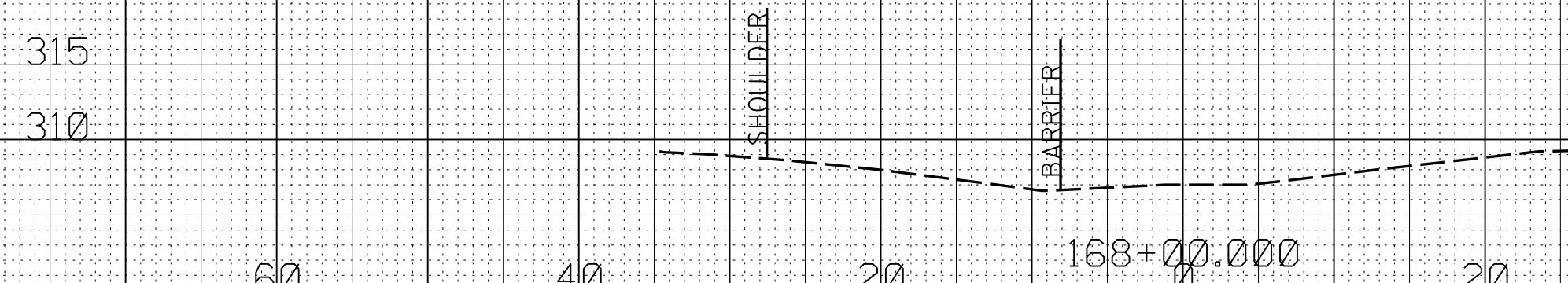
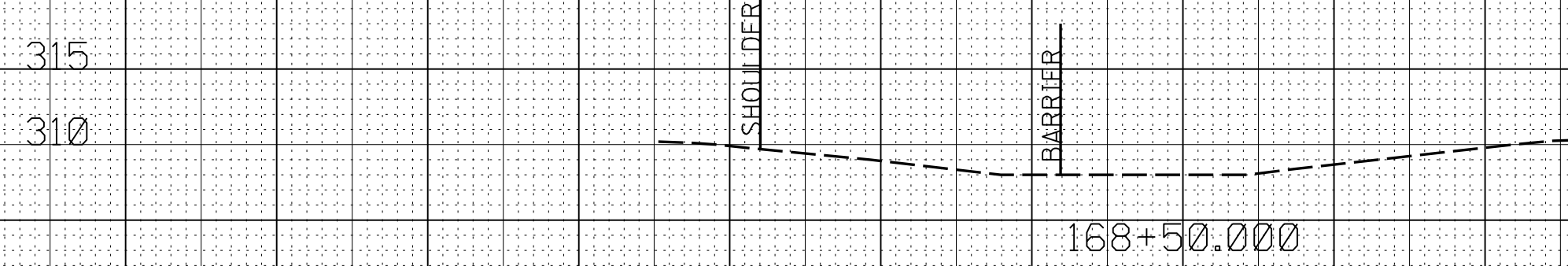
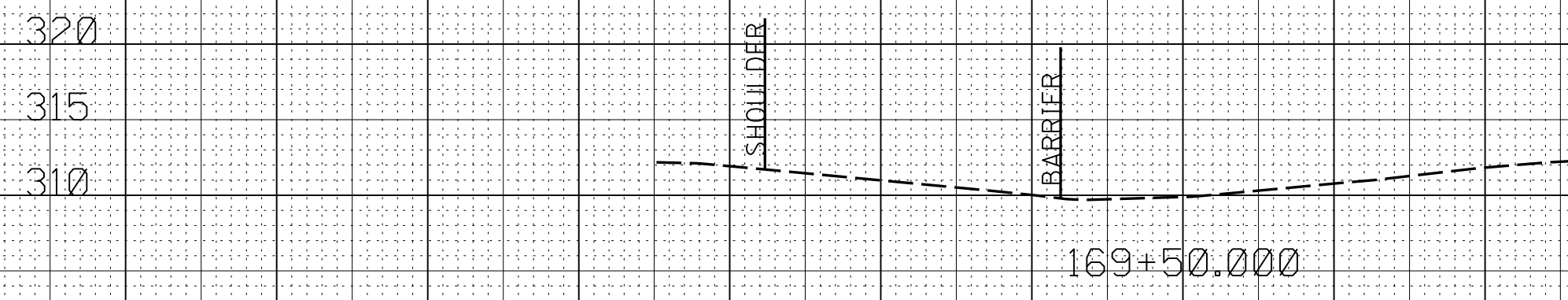
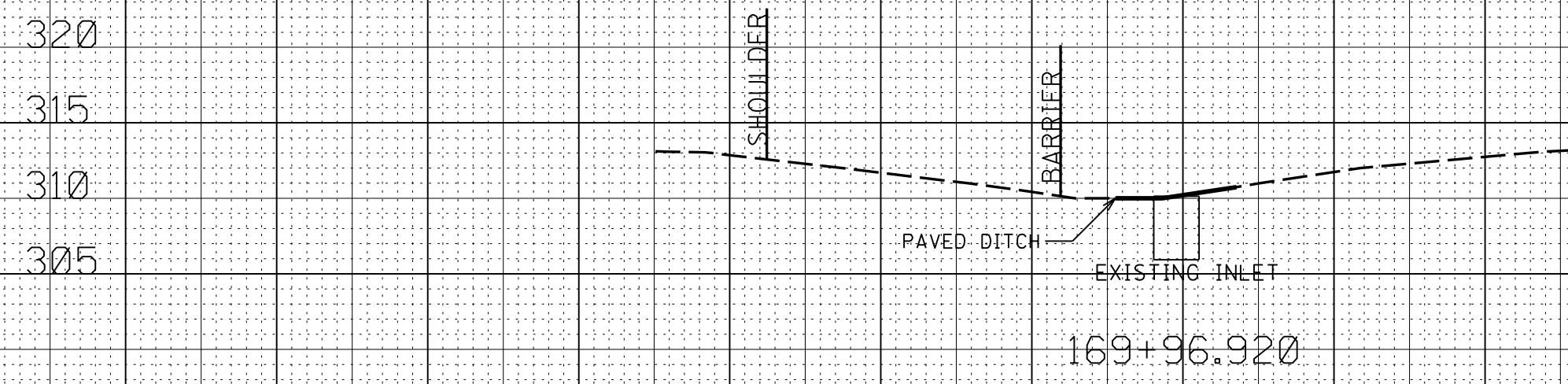
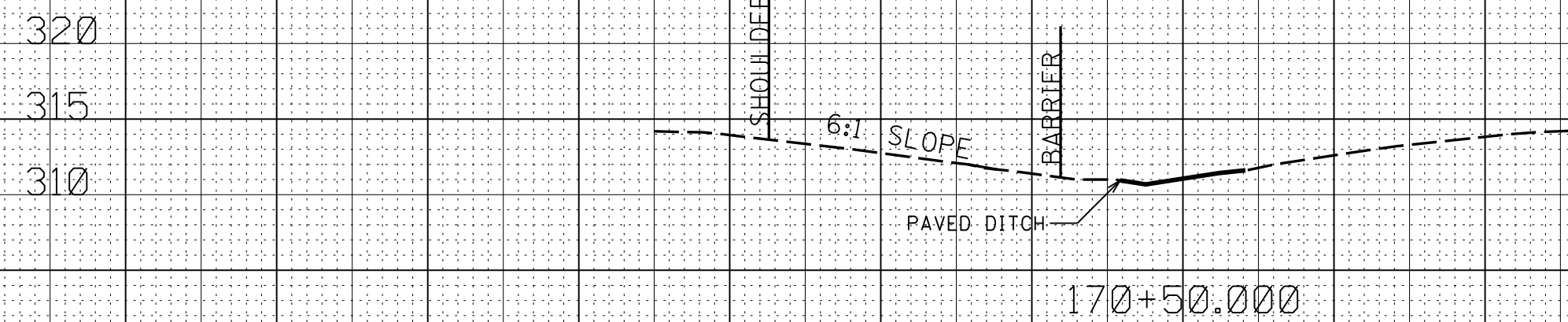
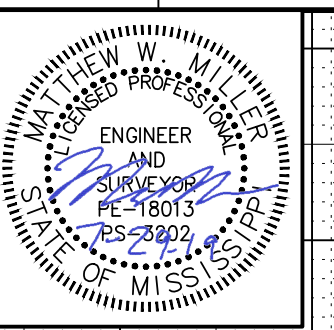

7/30/2019 8:35 AM LAY-HOLMES1.DGN

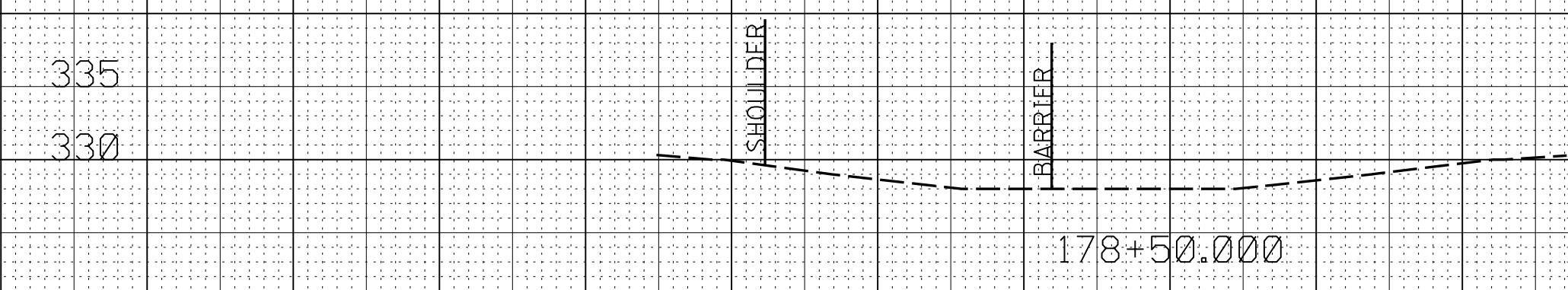
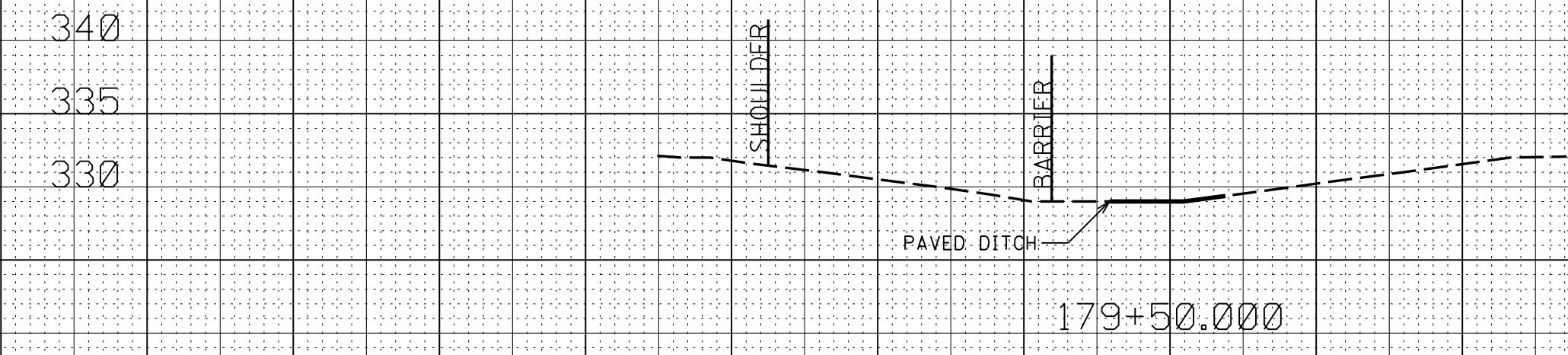
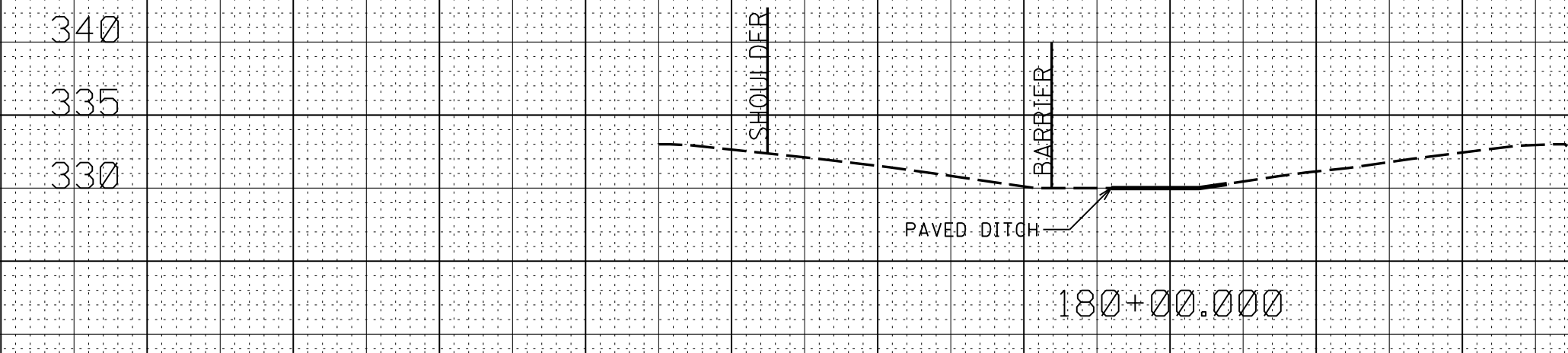
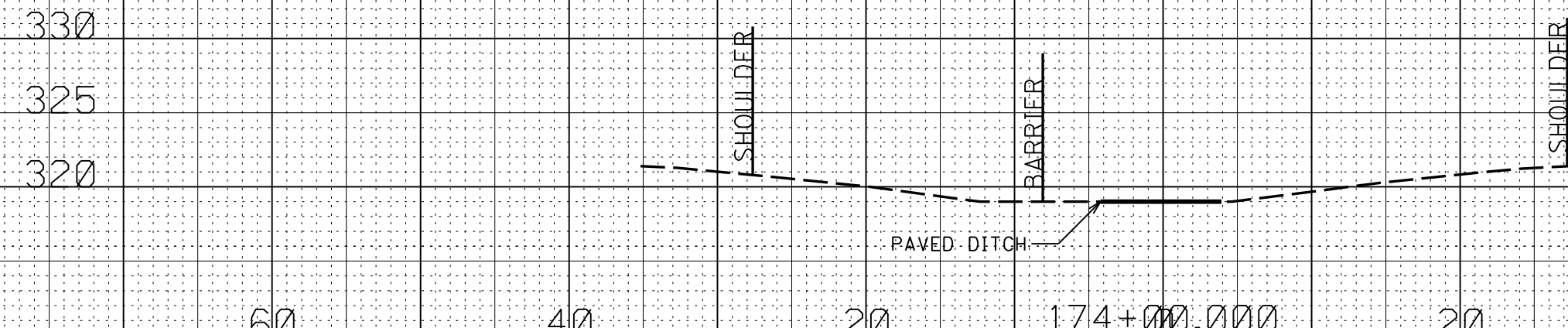
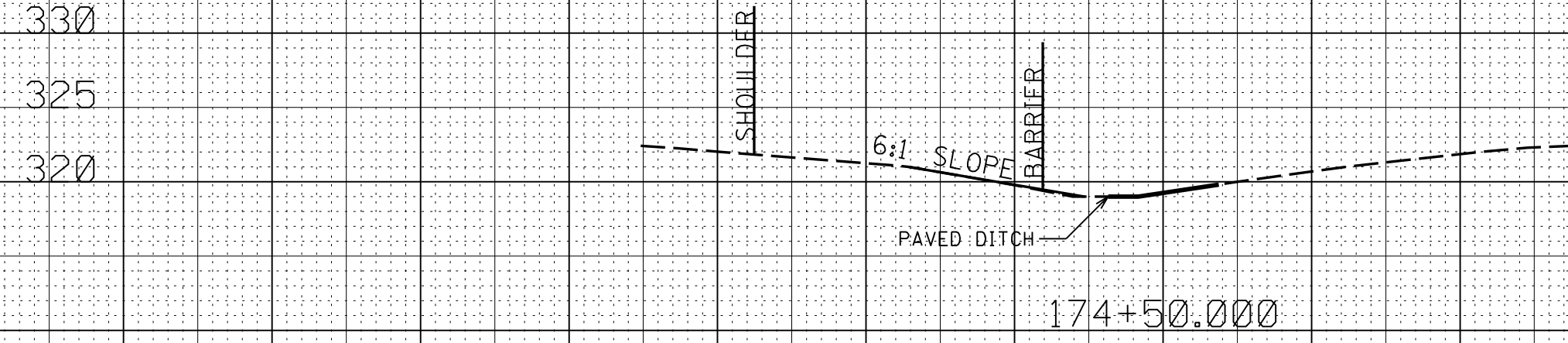
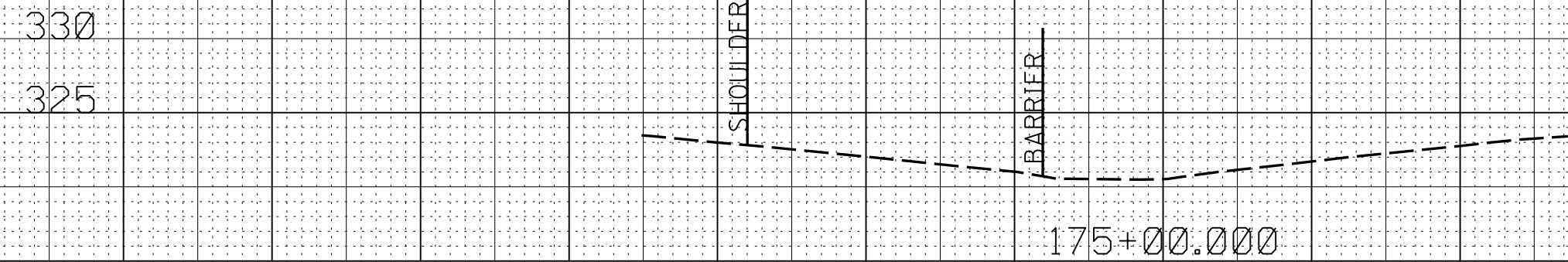
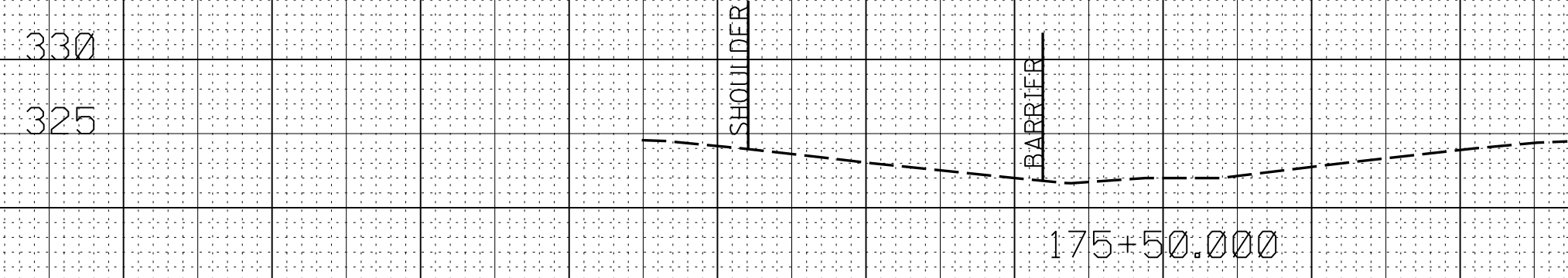
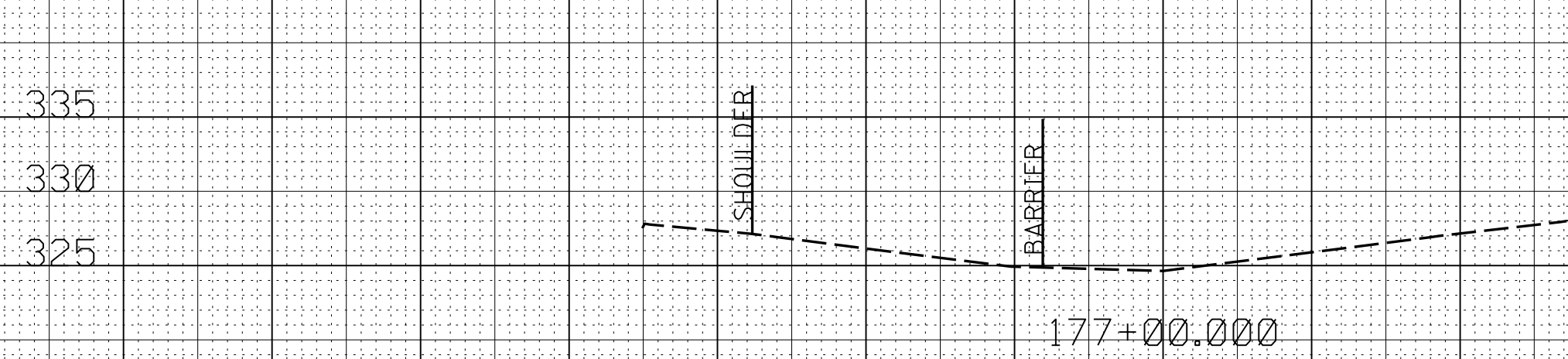
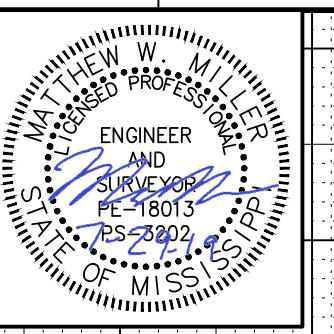

7/30/2019 8:35 AM LAY-HOLMES1.DGN

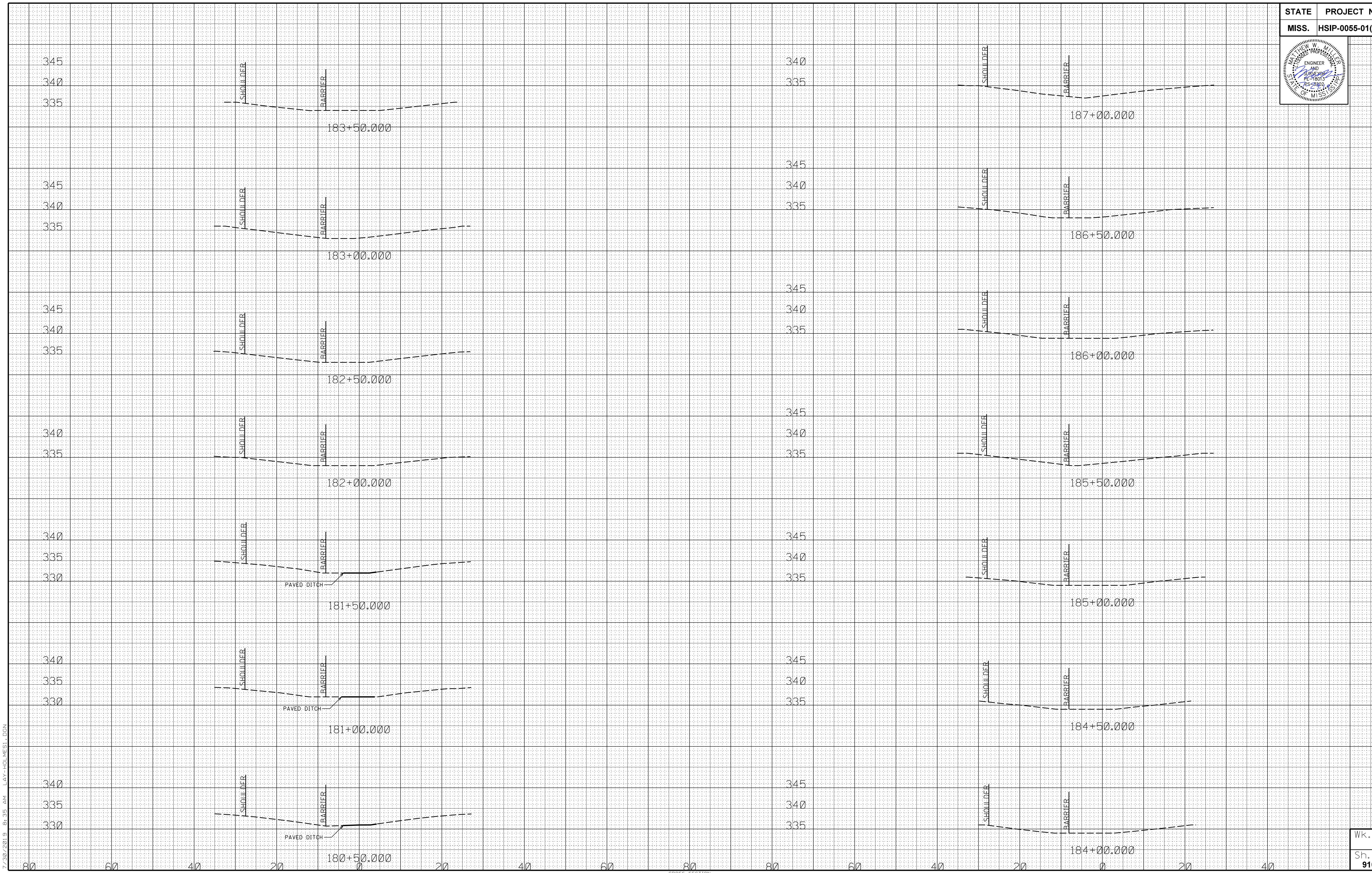
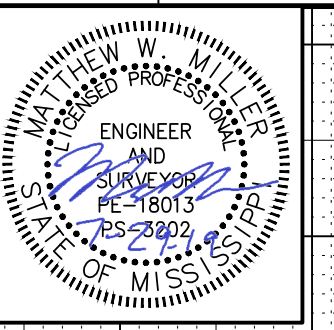

7/30/2019 8:35 AM LAY-HOLMES1.DGN

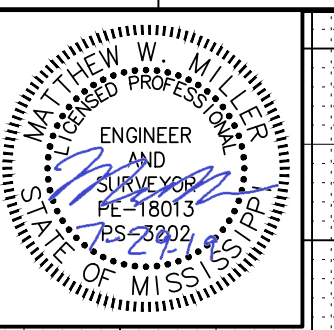

335
330
325
340
335
330
340
335
330
340
335
330
340
335
330
340
335
330
340
335
330

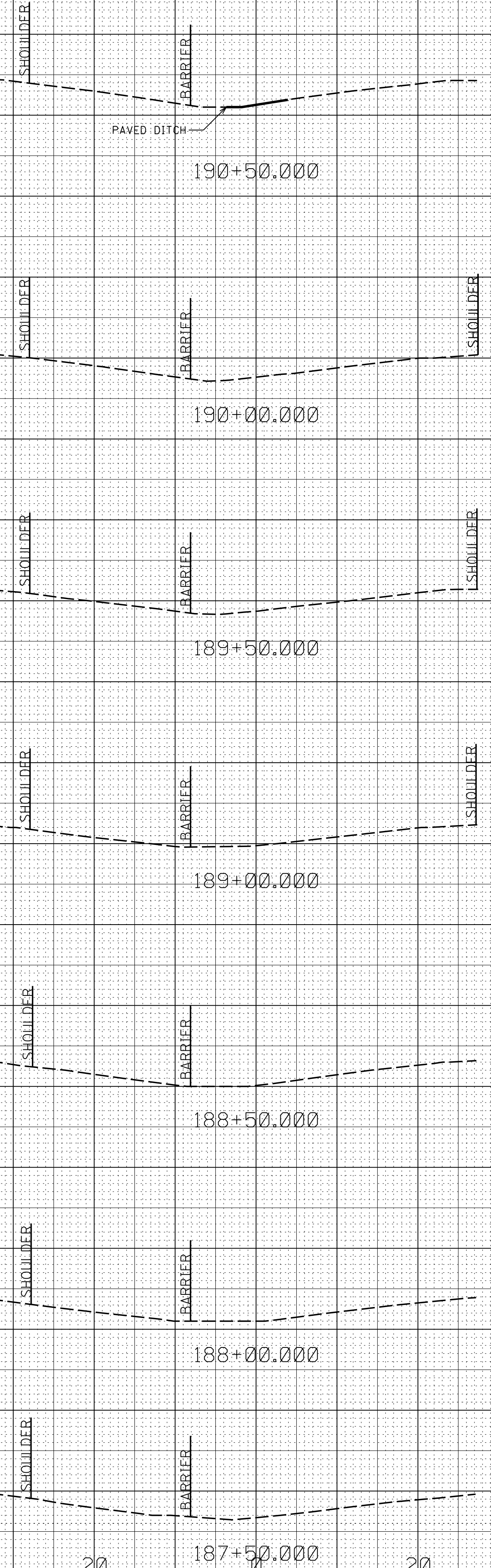

330
325
315
330
325
320
330
325
320
335
330
325
320
335
330
325
320

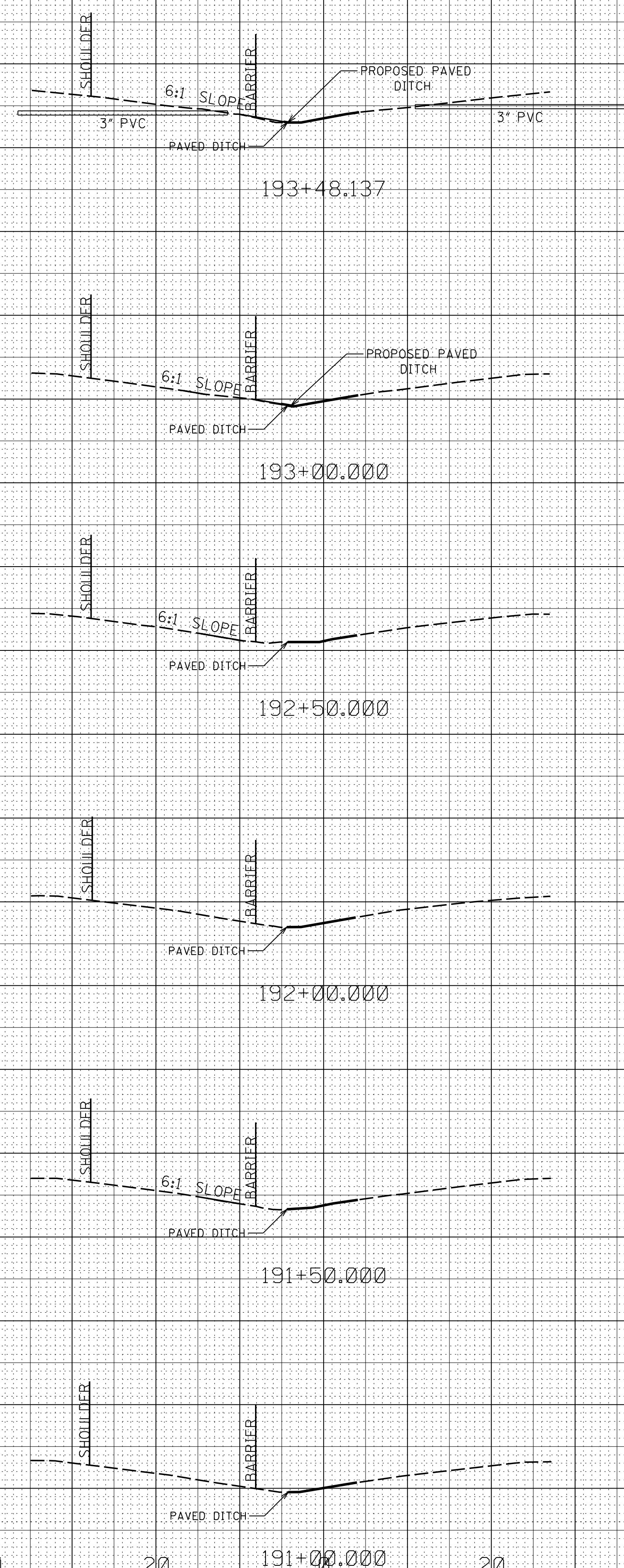

7/30/2019 8:35 AM LAY-HOLMES1.DGN

80 60 40 20 0 20 40 60 80 80 60 40 20 0 20 40 60 80

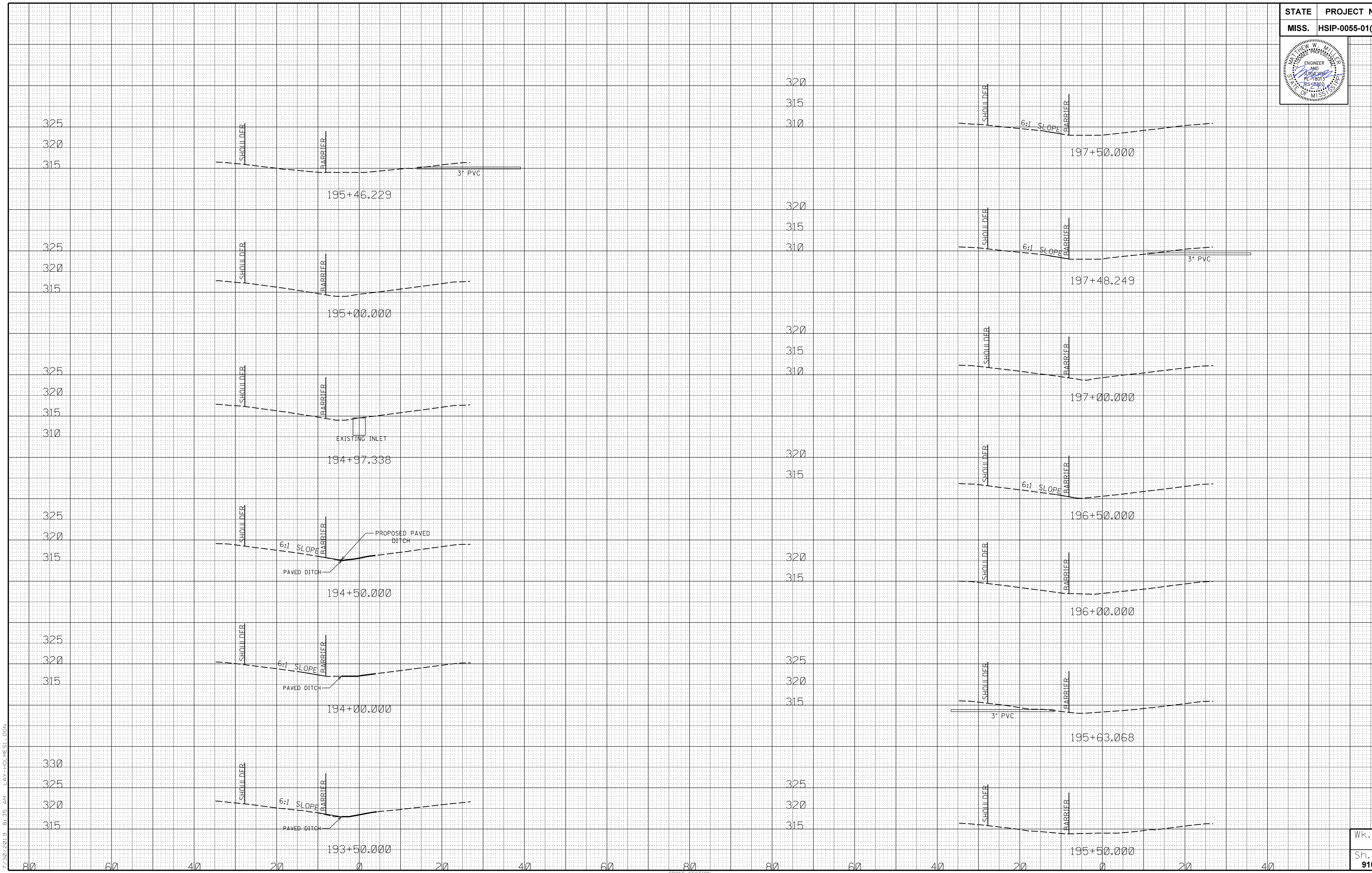
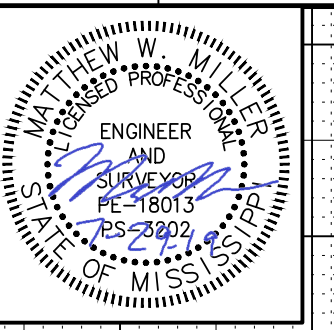

7/30/2019 8:35 AM LAY-HOLMES1.DGN

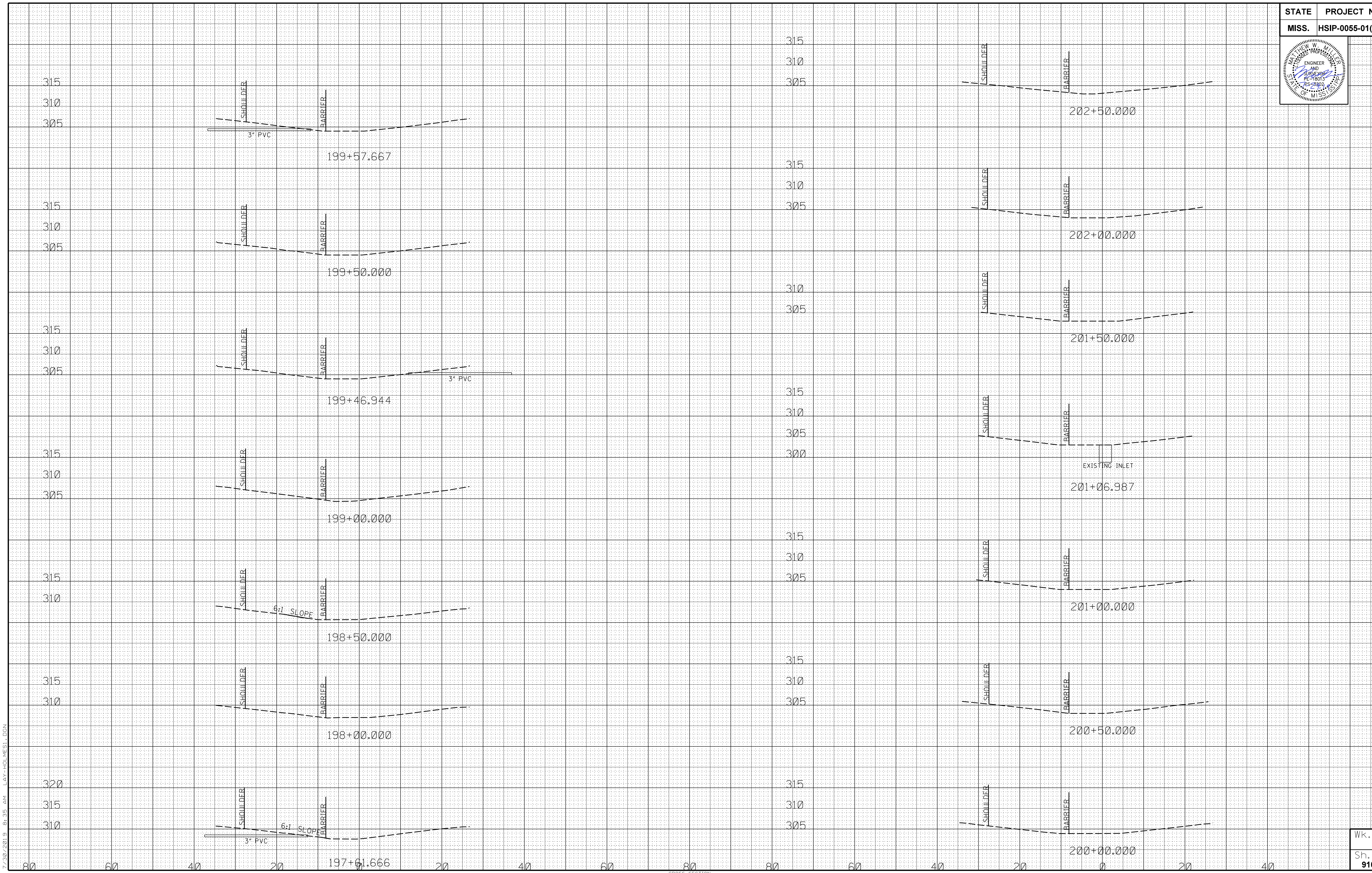
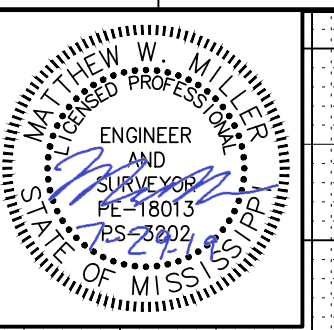

7/30/2019 8:35 AM LAY-HOLMES1.DGN

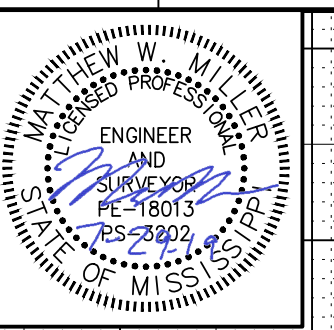

7/30/2019 8:35 AM LAY-HOLMES1.DGN

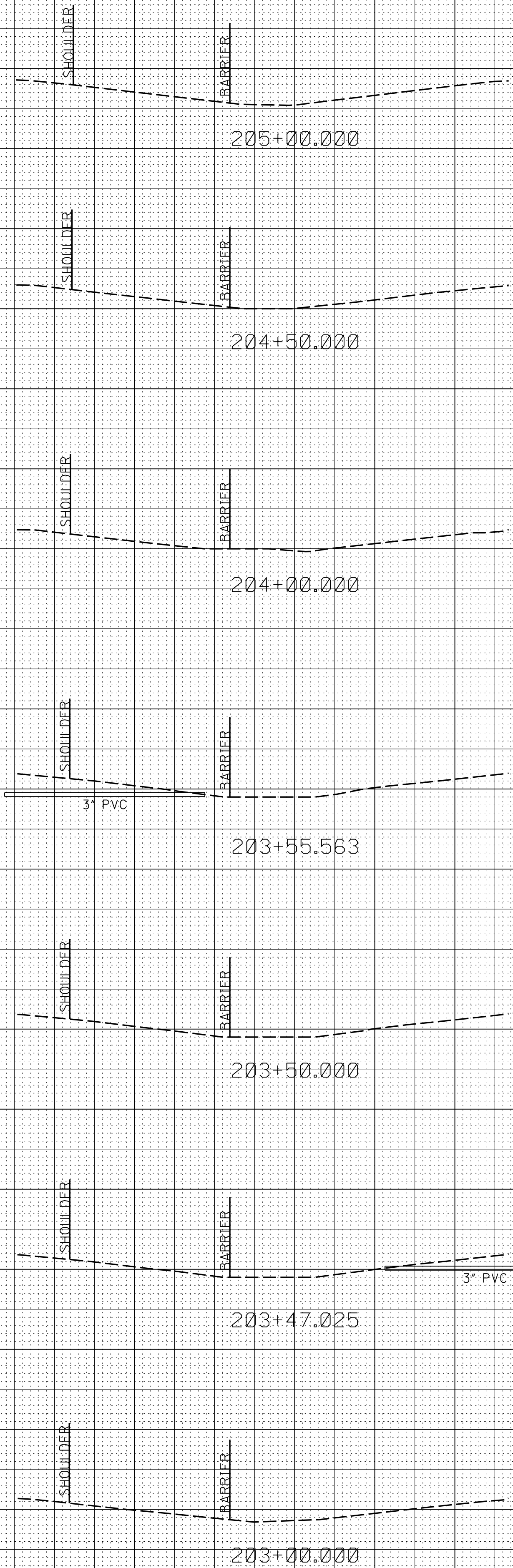

320
315
310
315
310
305
315
310
305
315
310
305
315
310
305
315
310
305
315
310
305
315
310
305

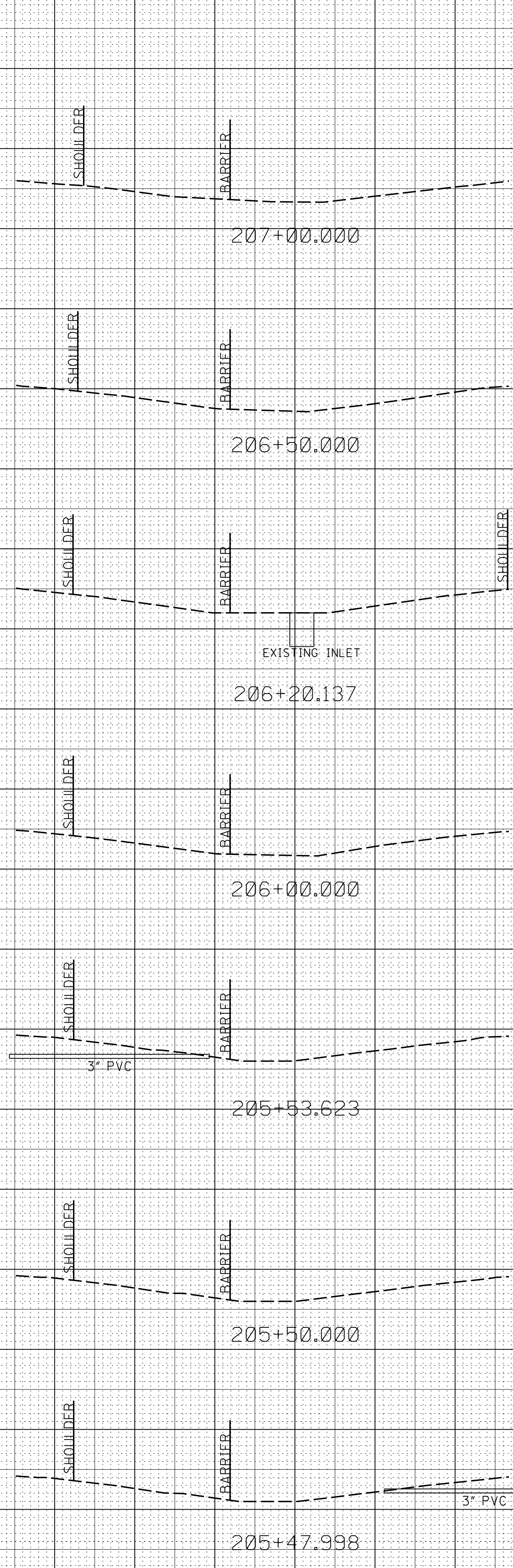

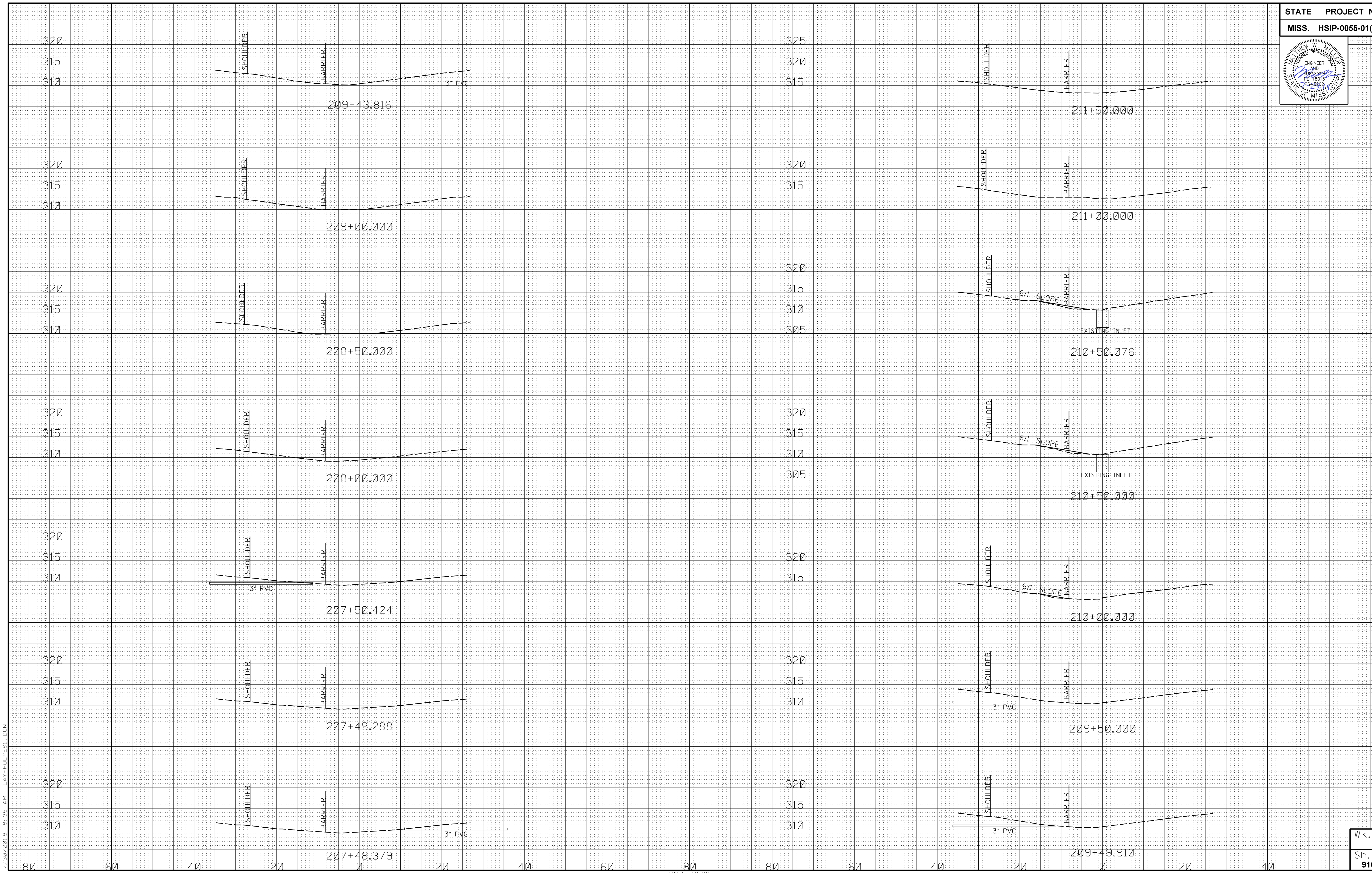
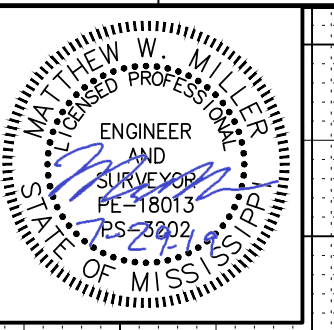

7/30/2019 8:35 AM LAY-HOLMES1.DGN

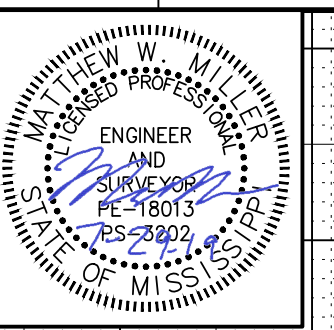

325

320

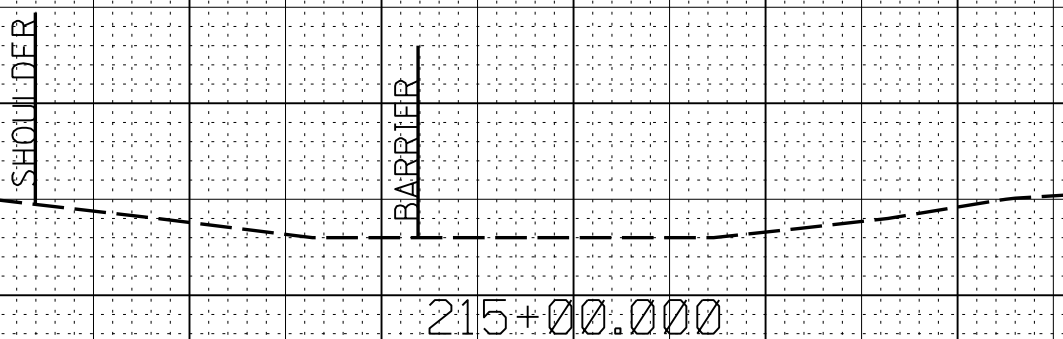

330

325

320

315

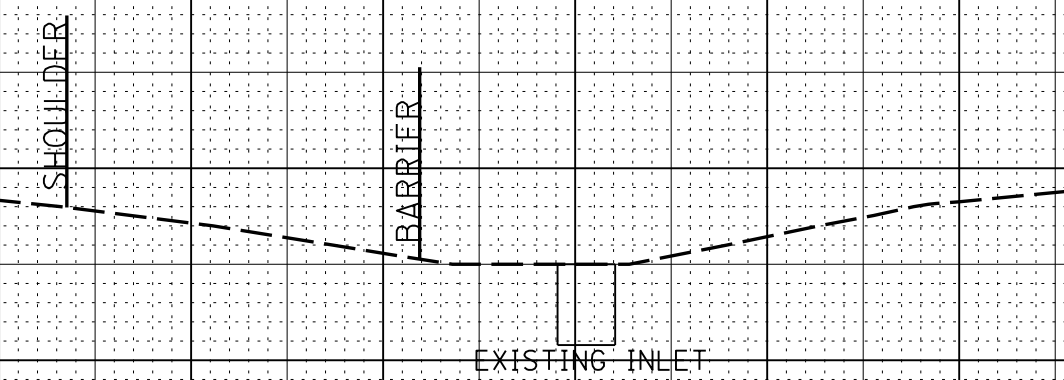

325

320

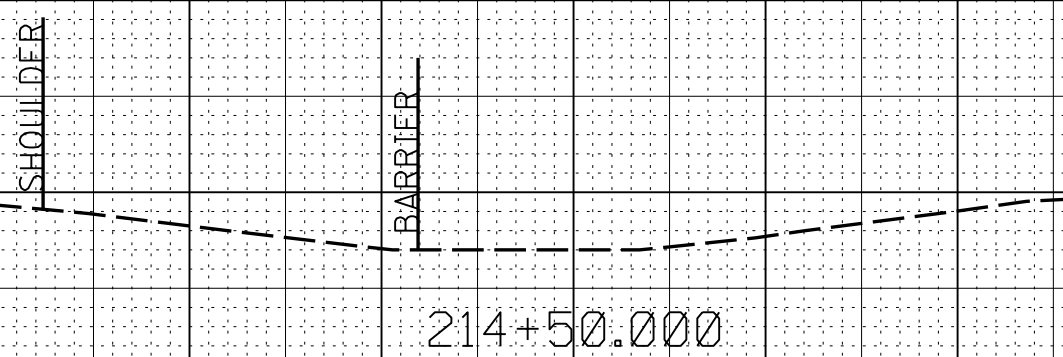

330

325

320

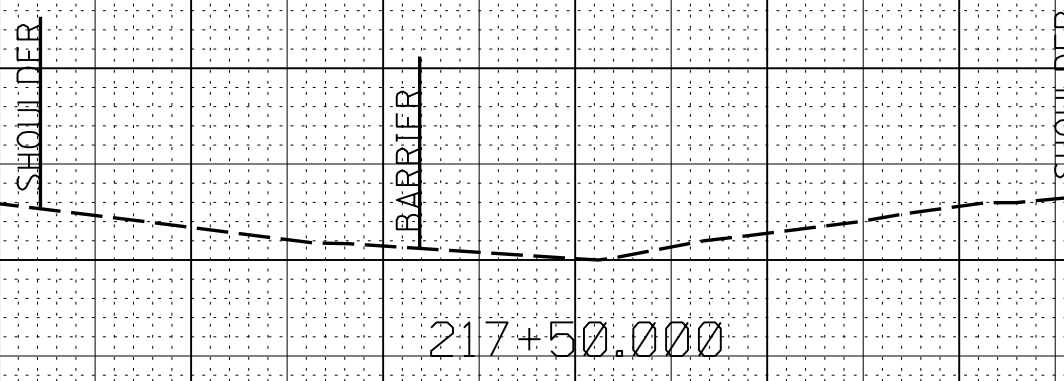

325

320

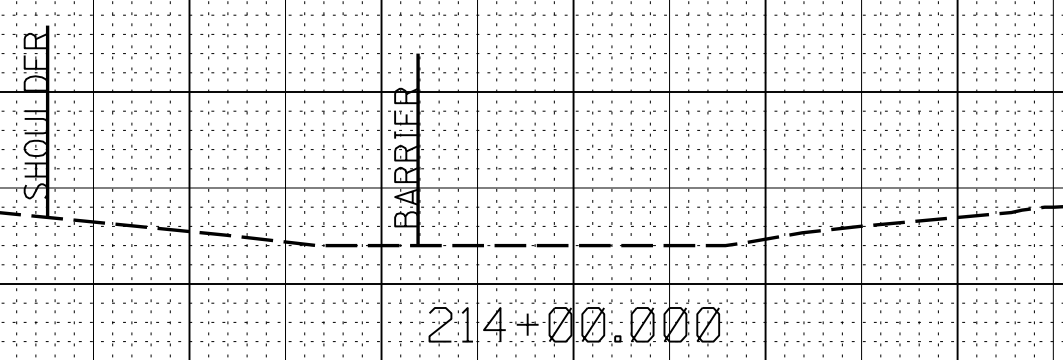

325

320

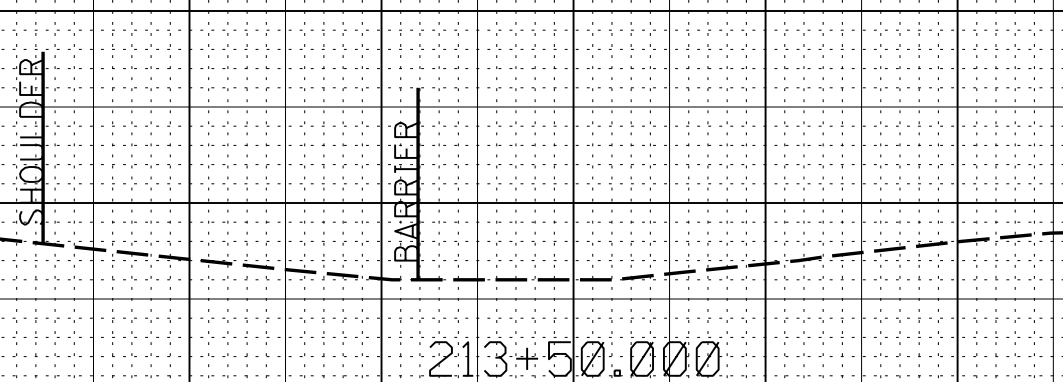

330

325

320

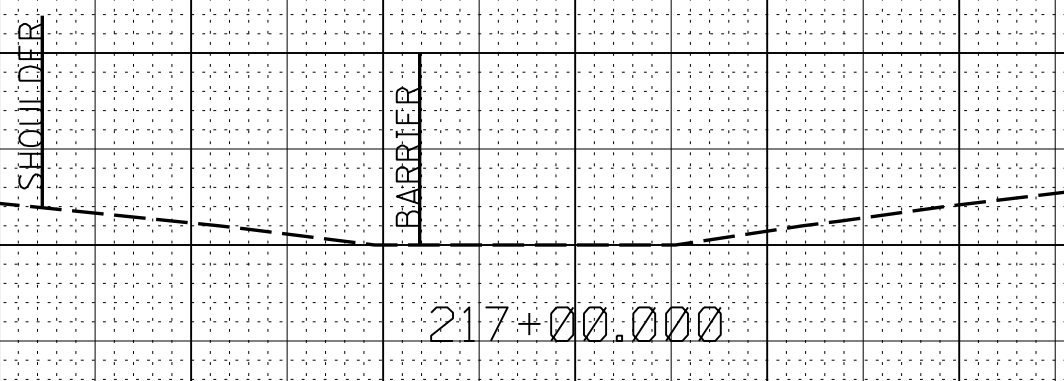

325

320

315

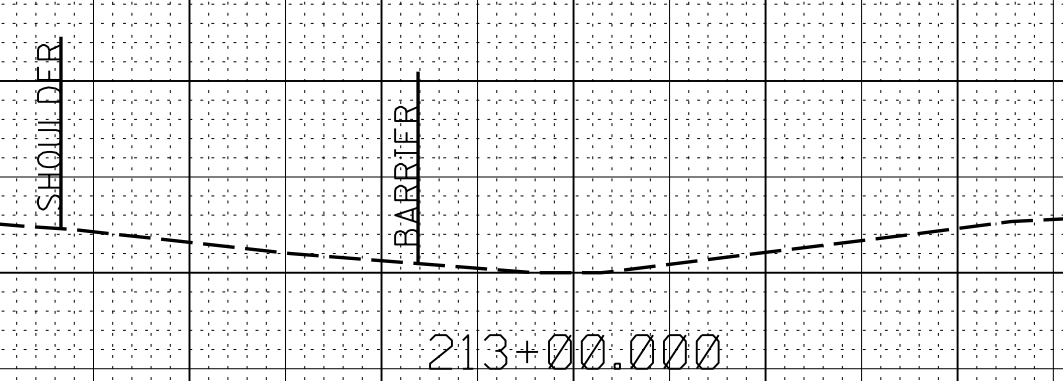

330

325

320

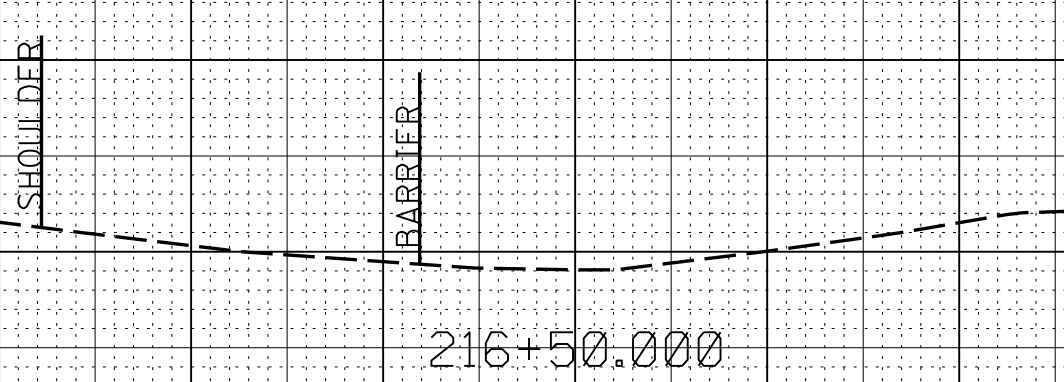

325

320

315

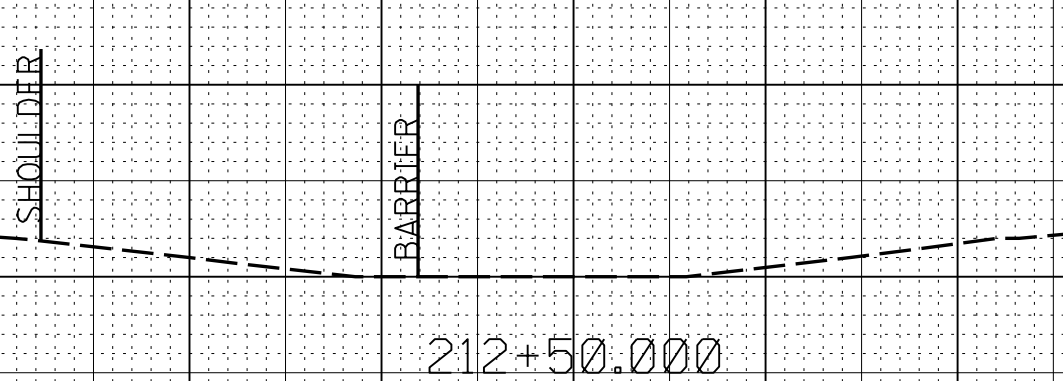

330

325

320

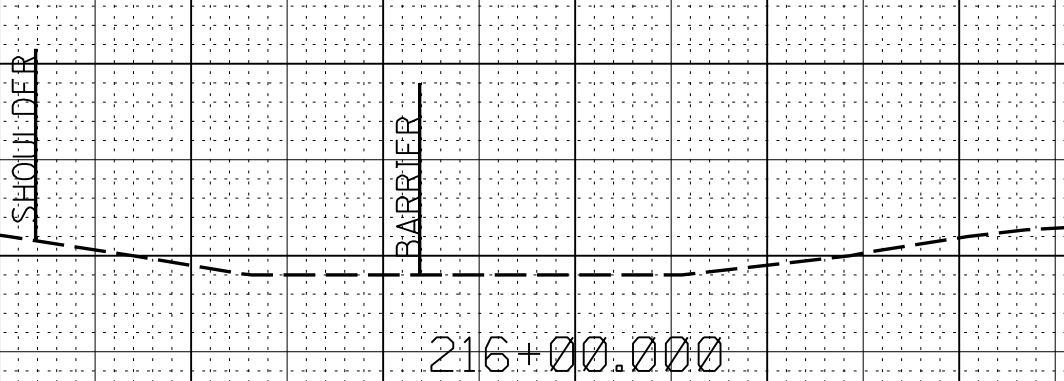

325

320

315

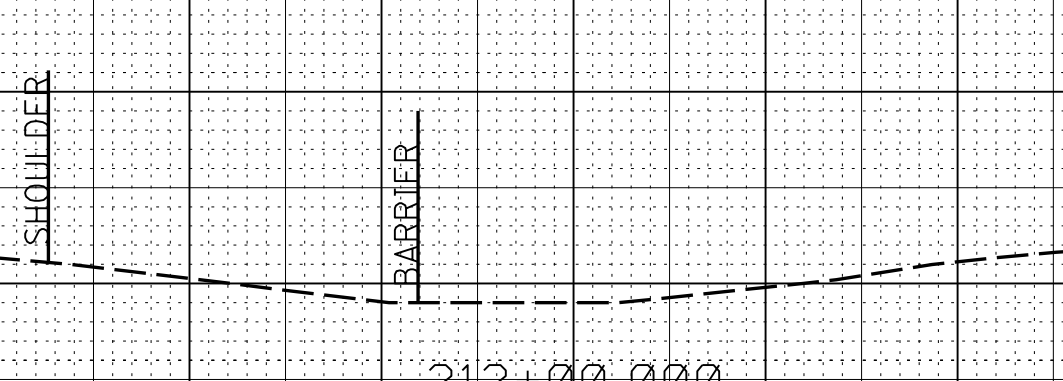

330

325

320

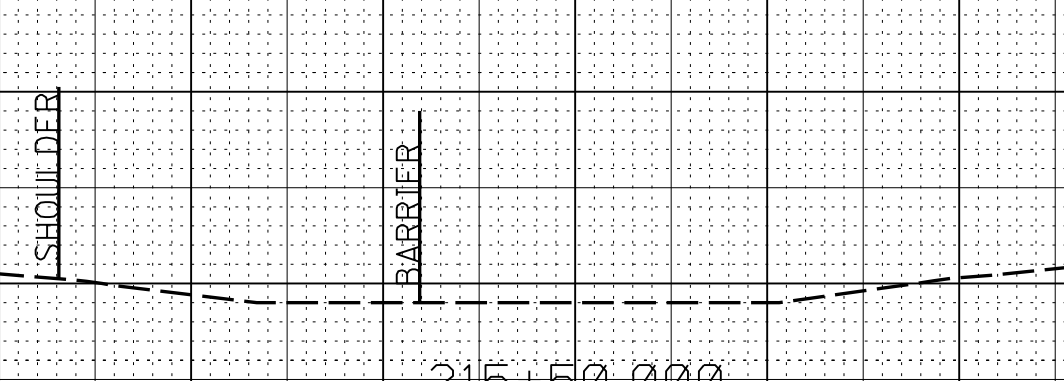

7/30/2019 8:35 AM LAY-HOLMES1.DGN

80 60 40 20 0 20 40 60 80 80 60 40 20 0 20 40

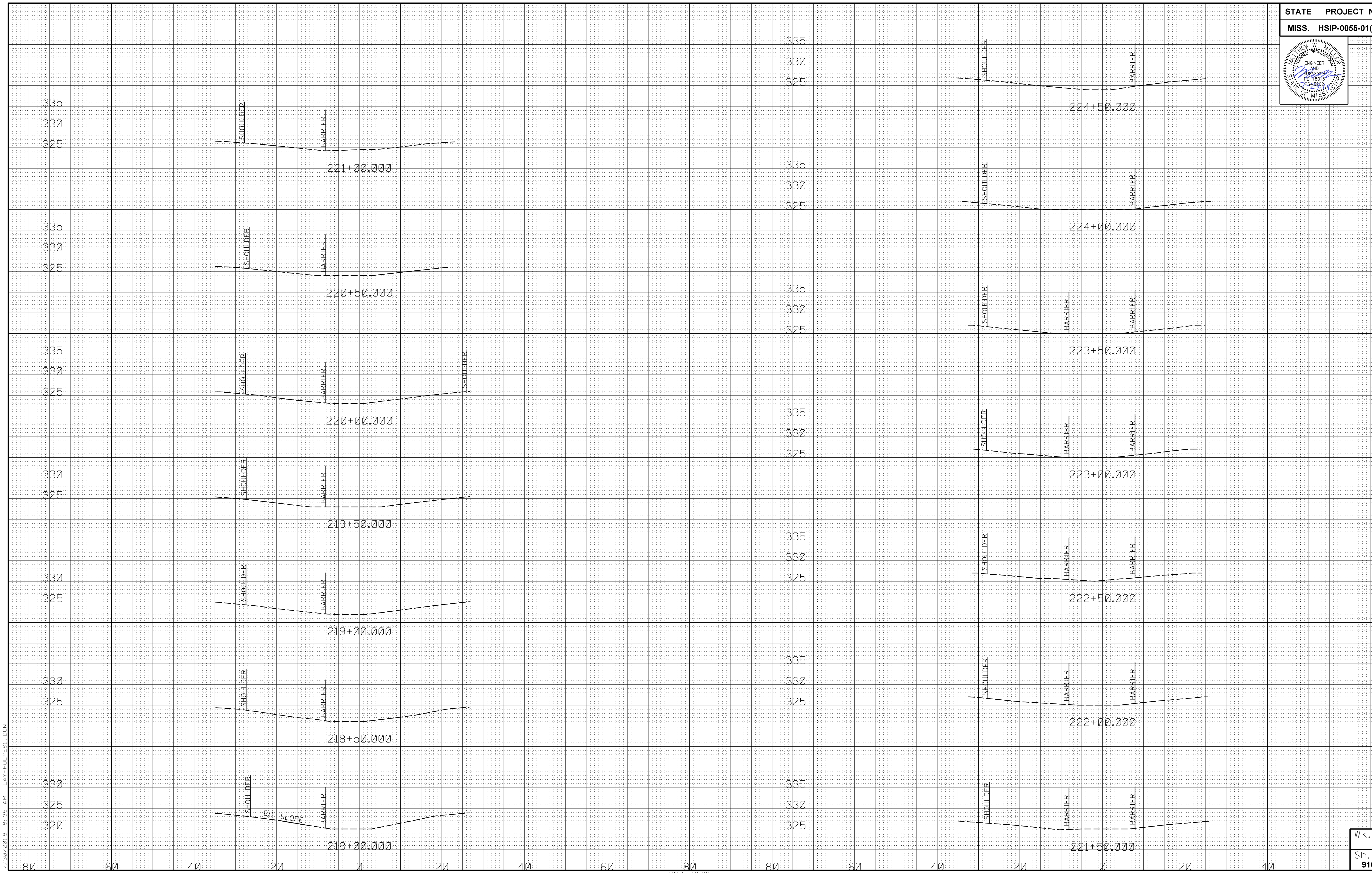
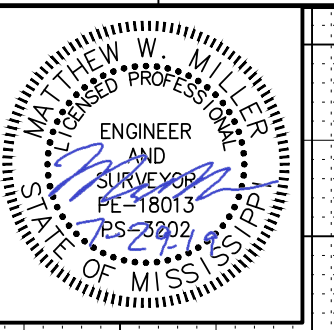

7/30/2019 8:35 AM LAY-HOLMES1.DGN

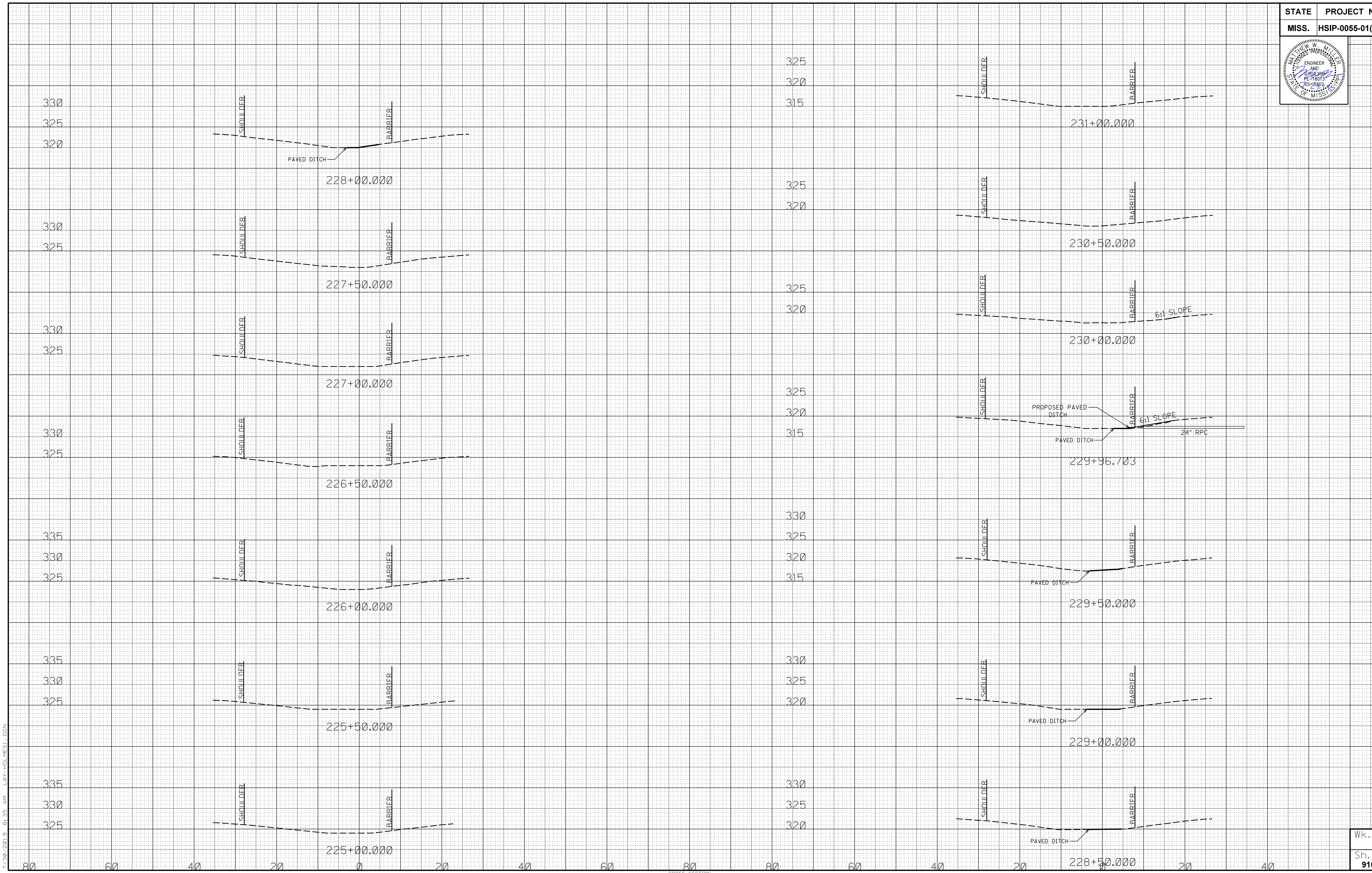
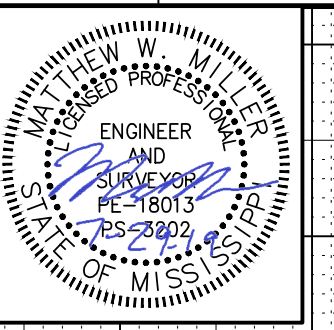

7/30/2019 8:35 AM LAY-HOLMES1.DGN

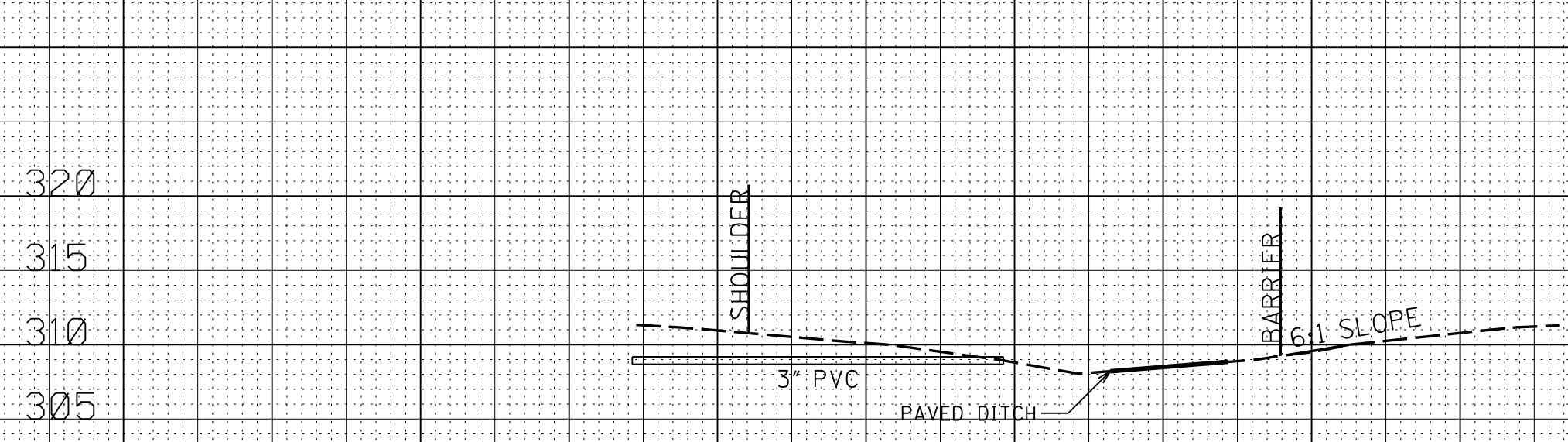
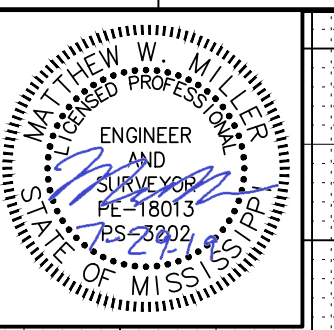

233+94.292

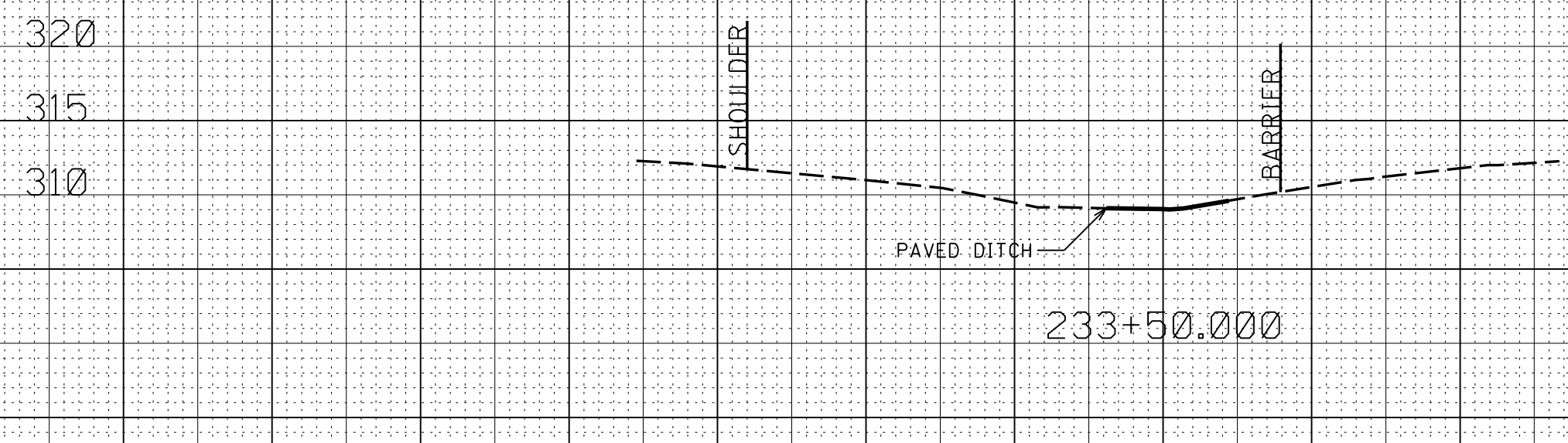

233+50.000

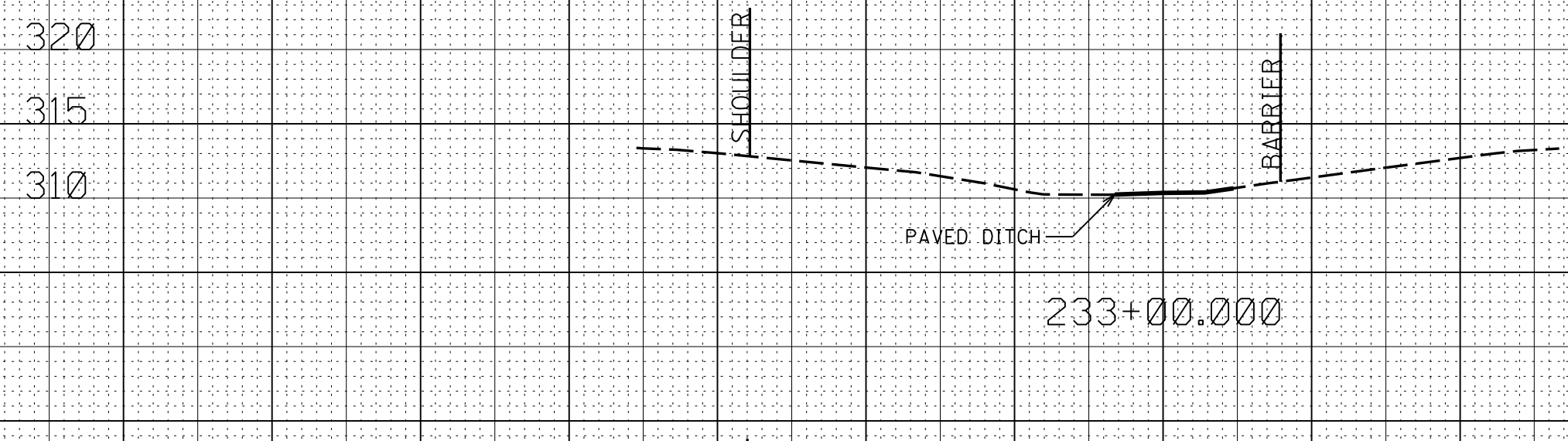

233+00.000

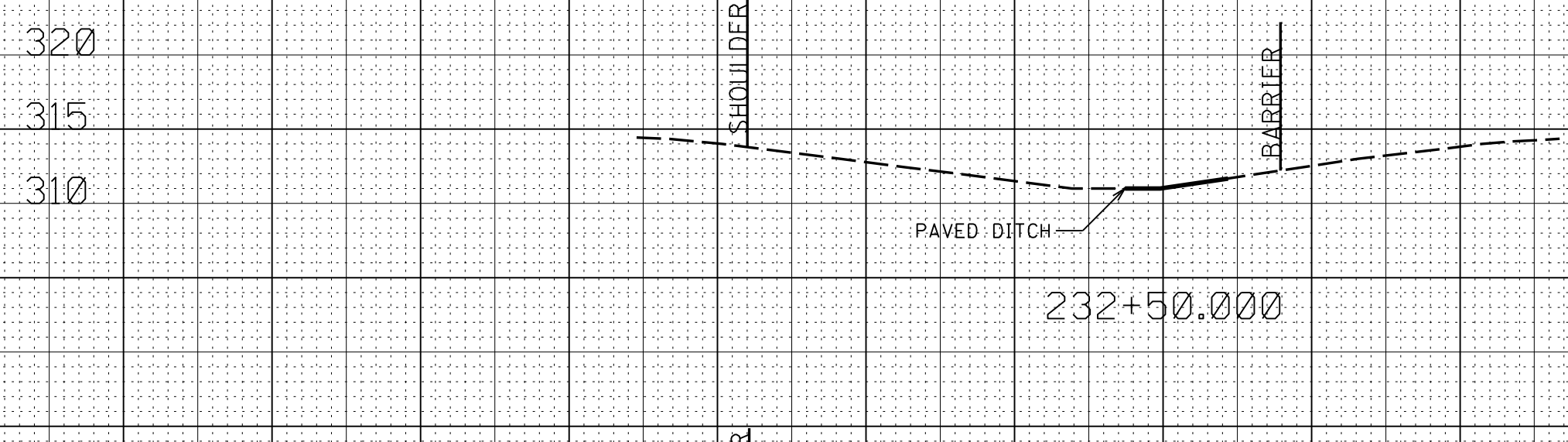

232+50.000

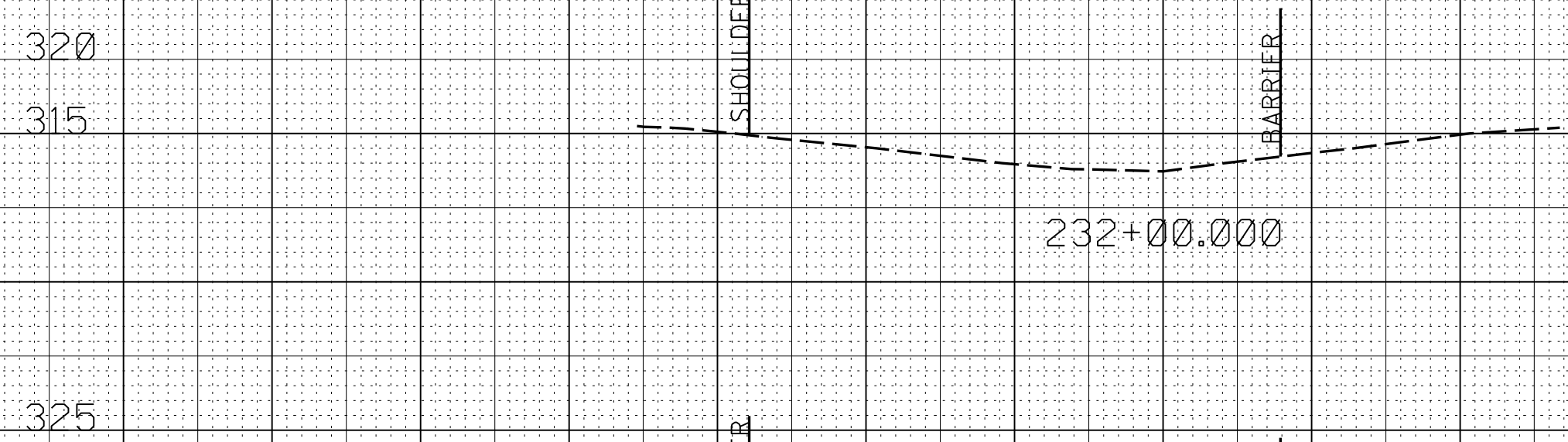

232+00.000

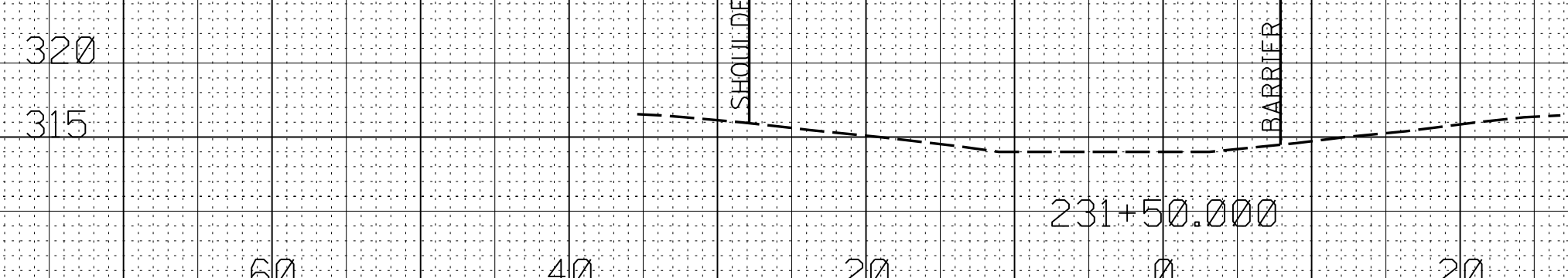

231+50.000

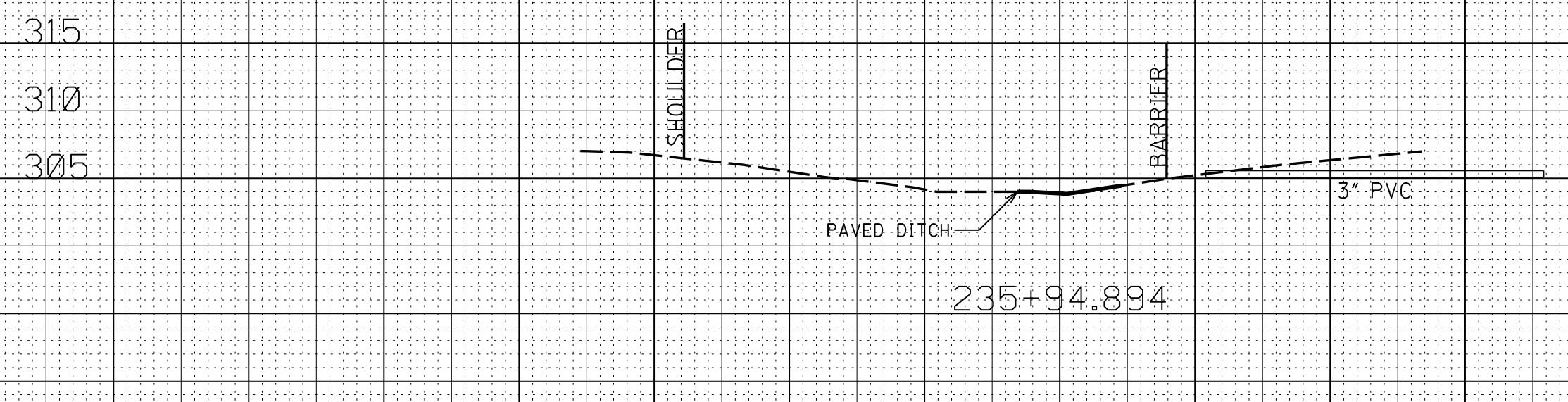

235+94.894

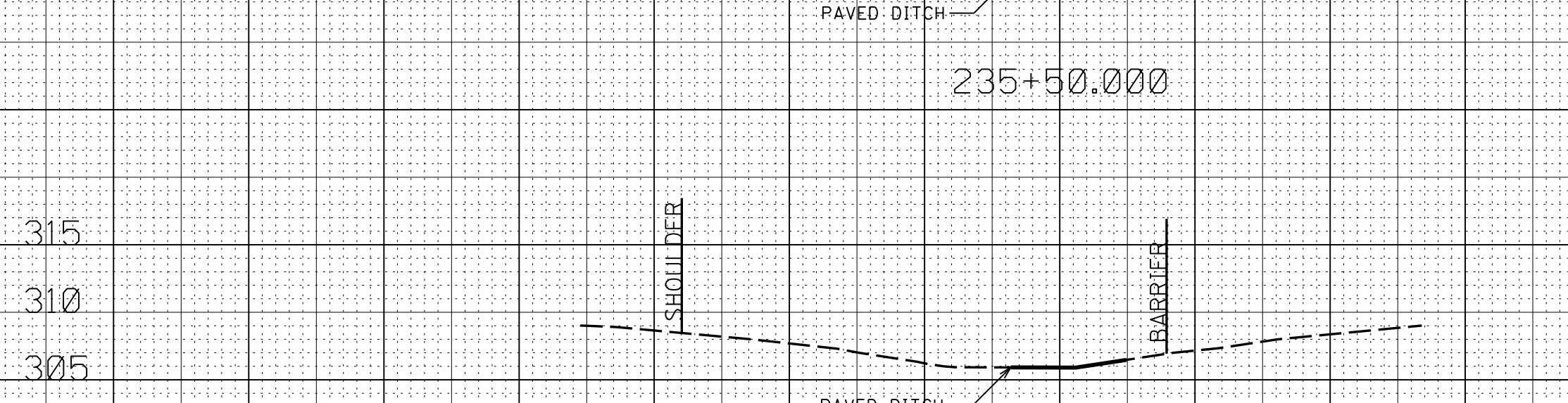

235+50.000

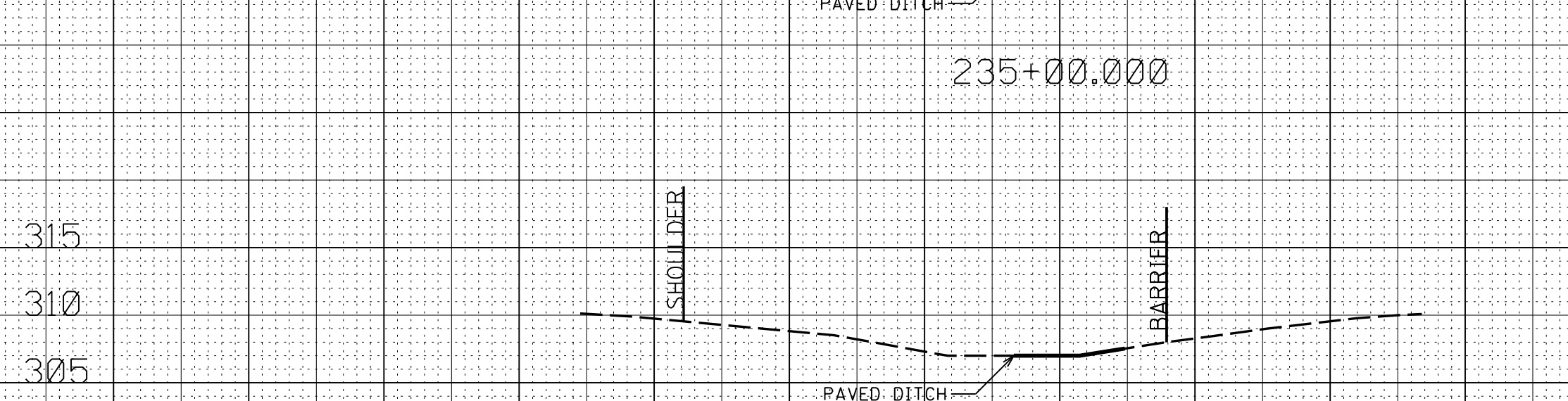

235+00.000

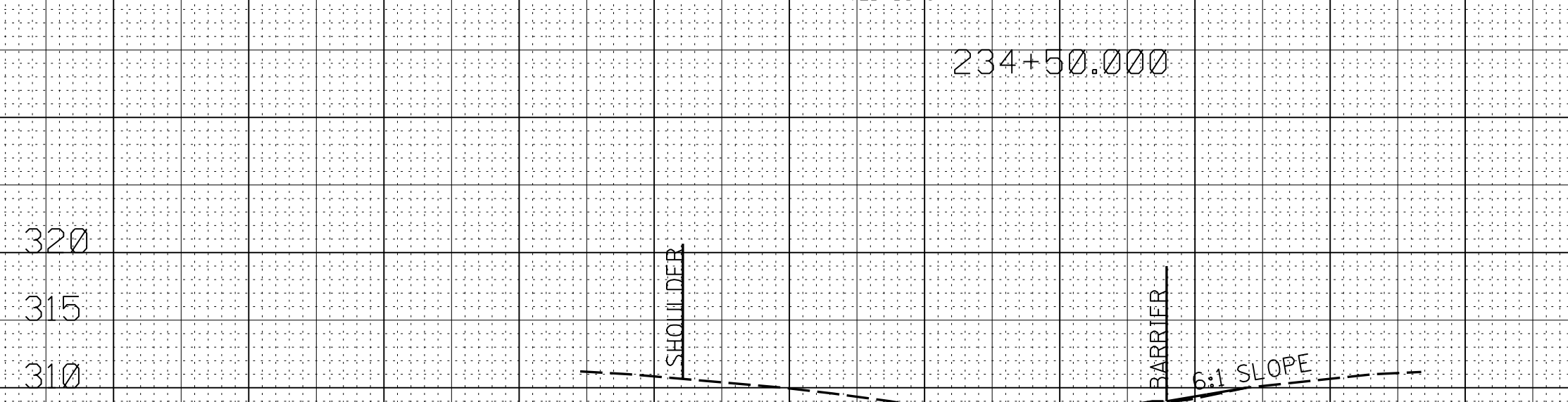

234+50.000

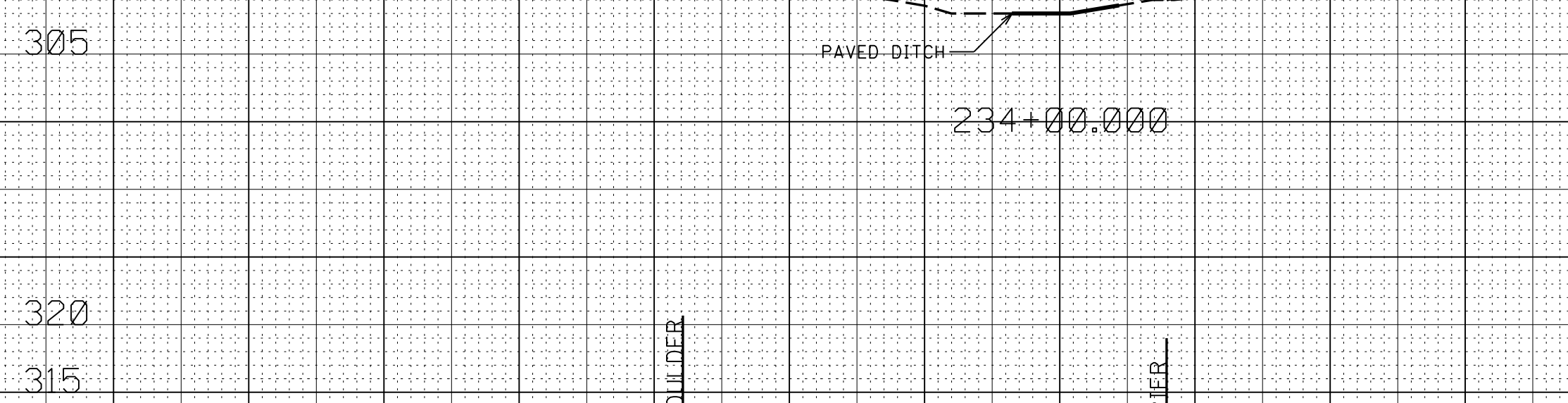

234+00.000

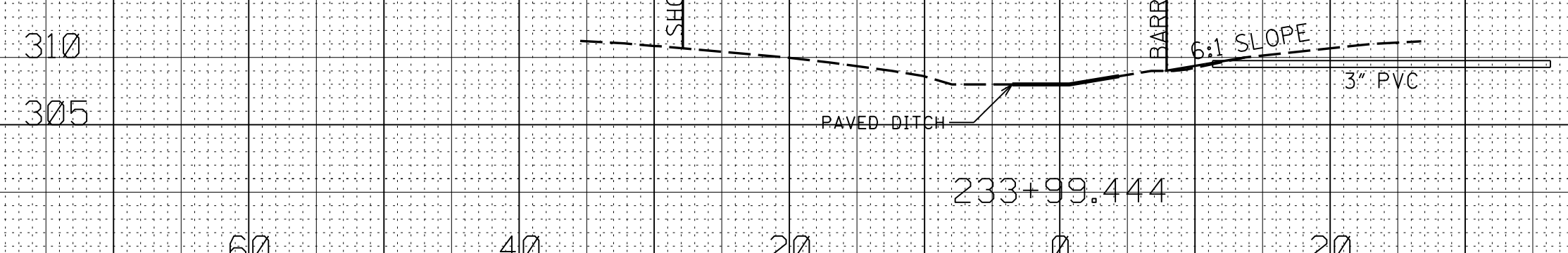

233+99.444

7/30/2019 8:35 AM LAY-HOLMES1.DGN

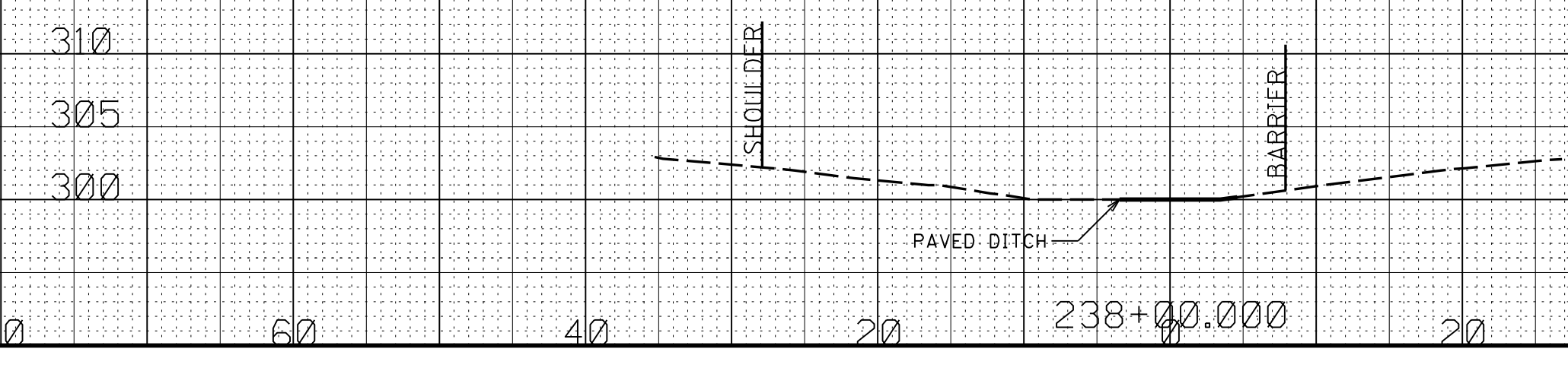
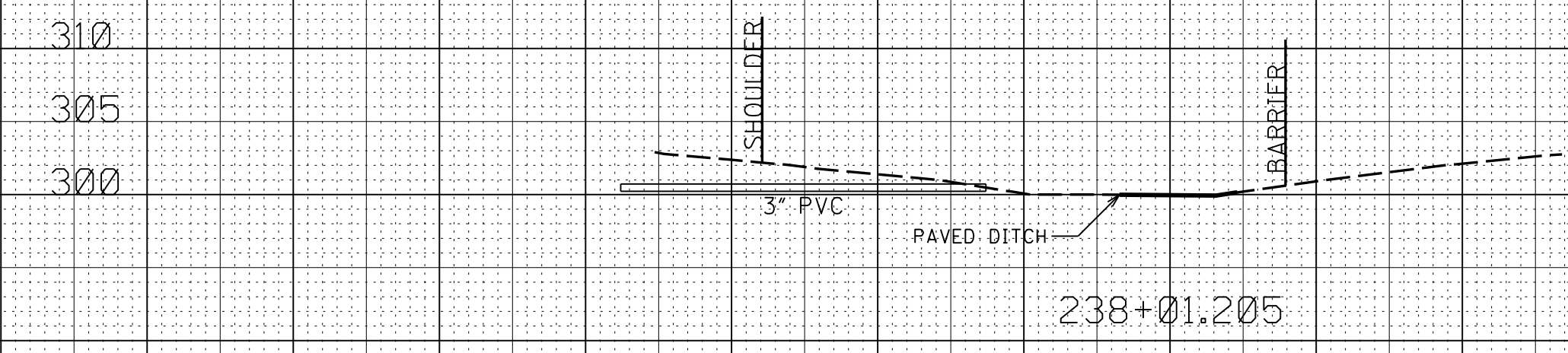
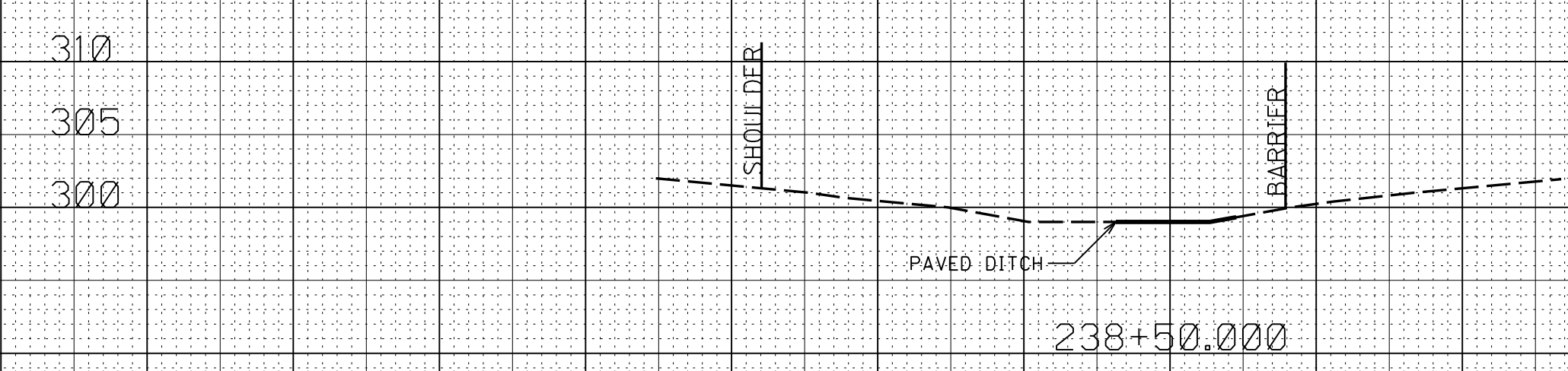
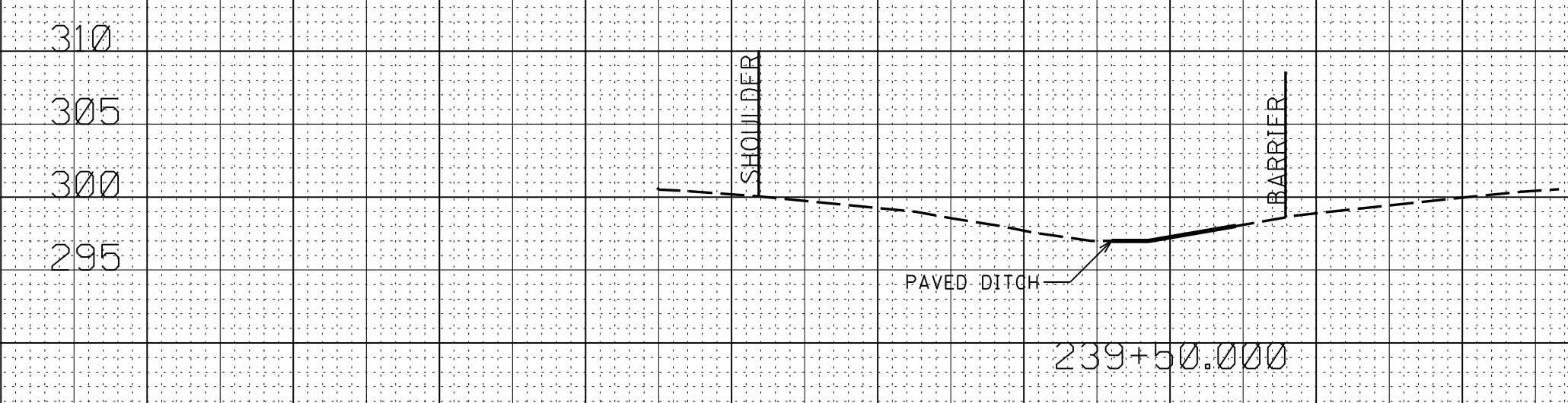
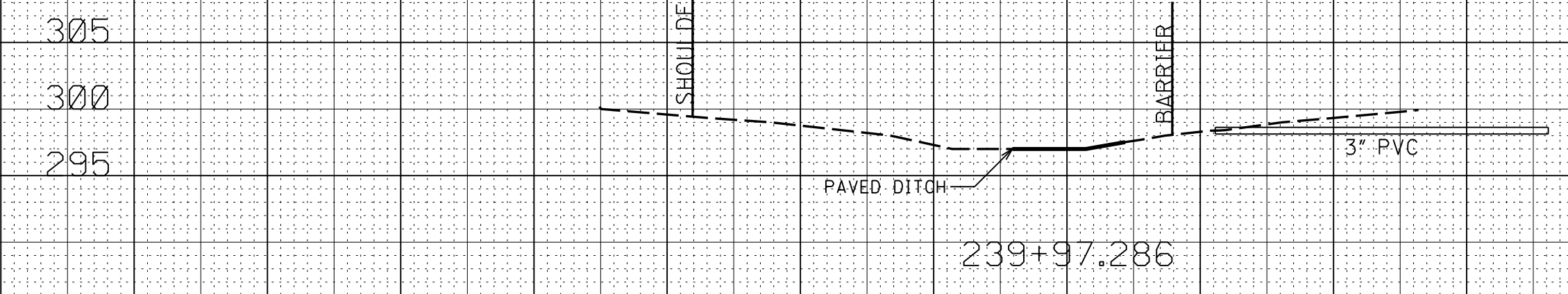
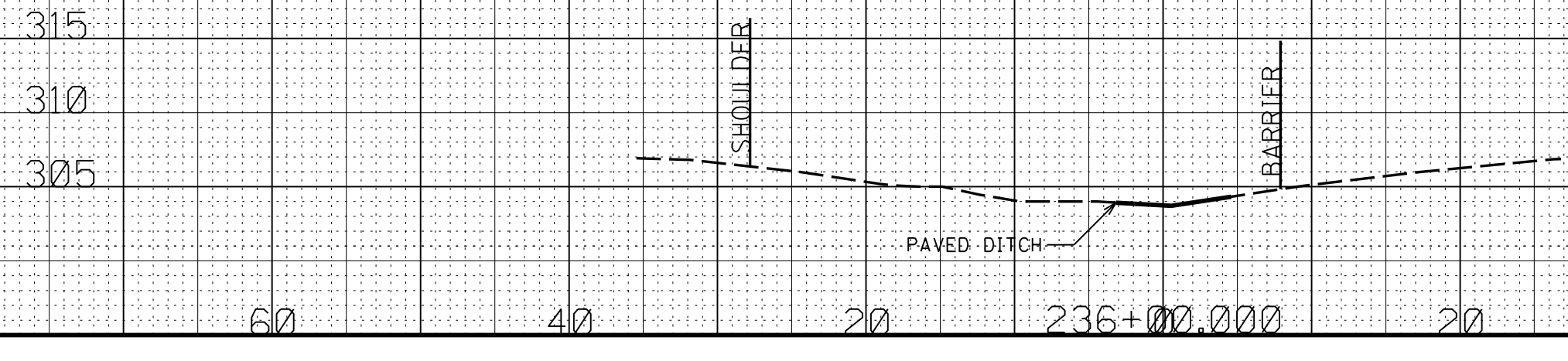
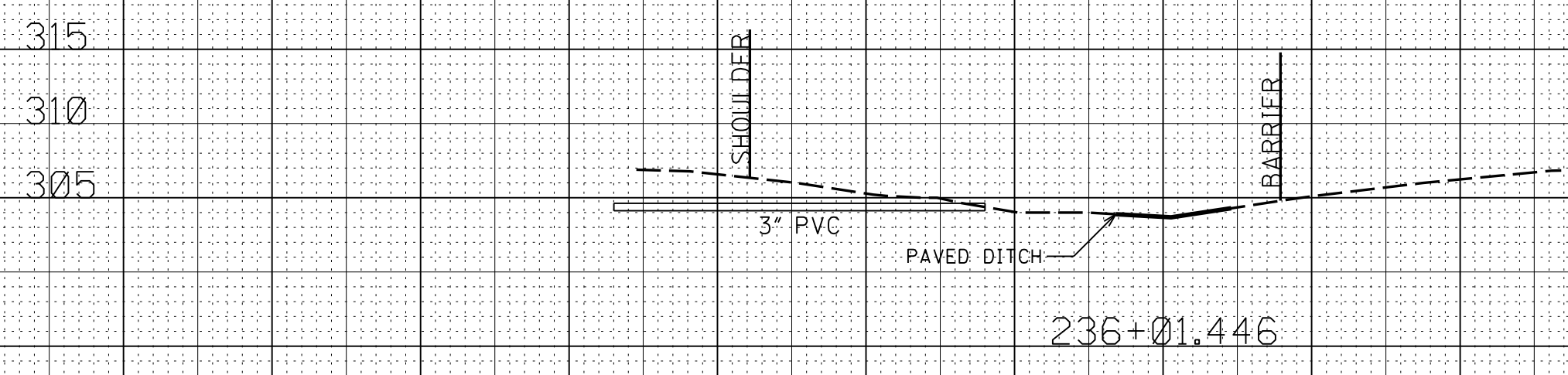
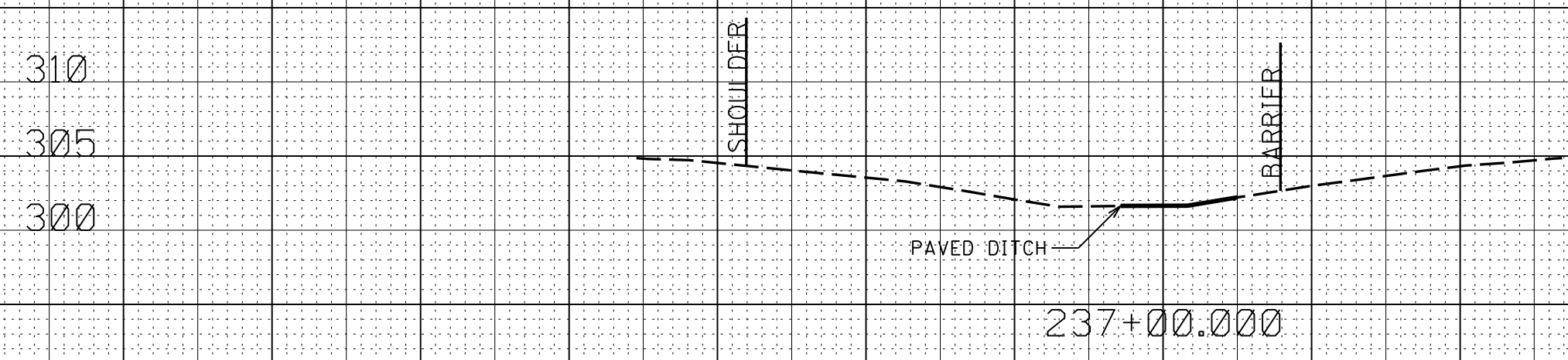
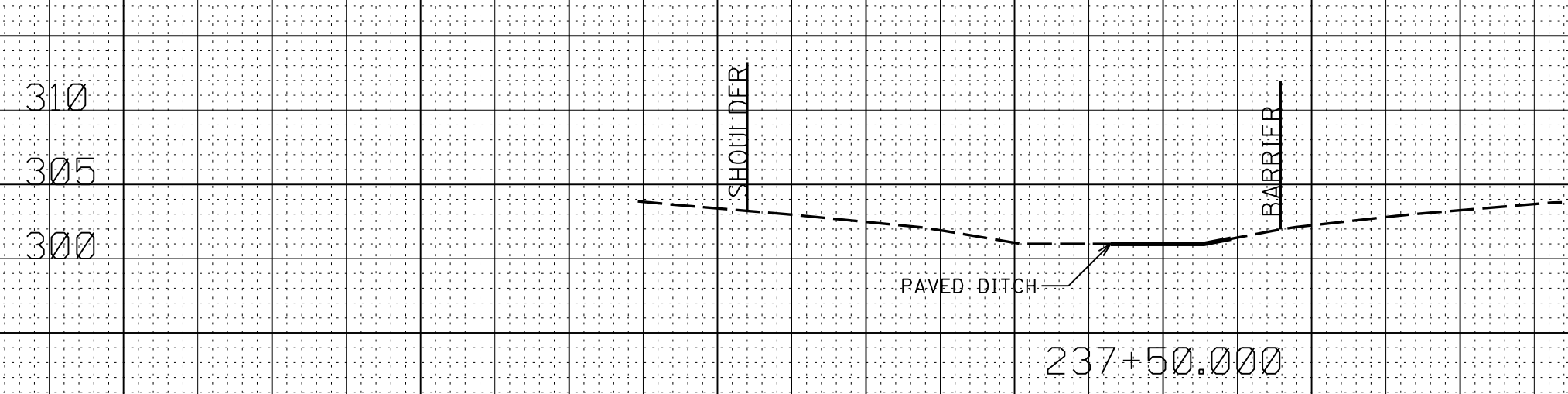
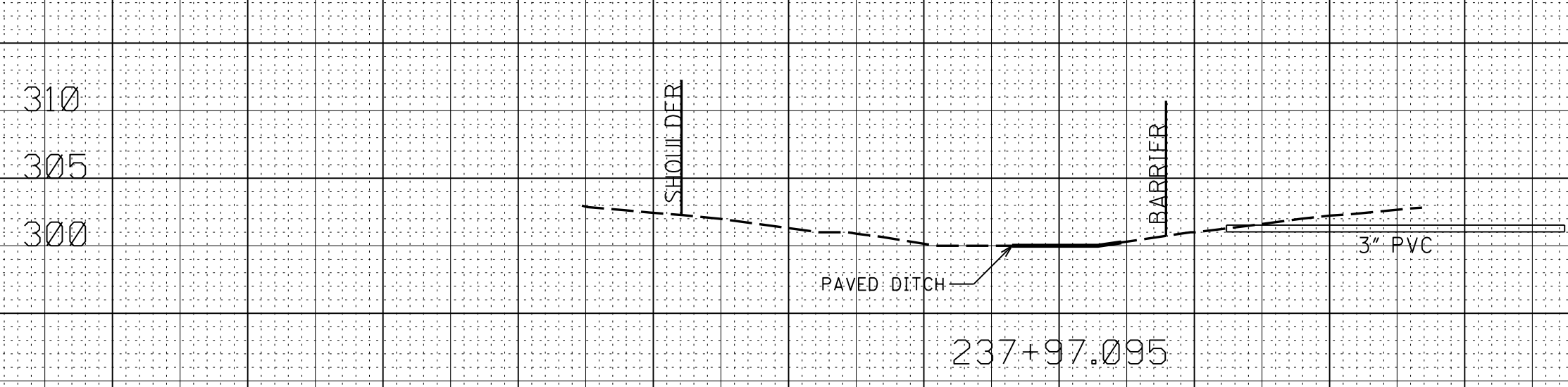
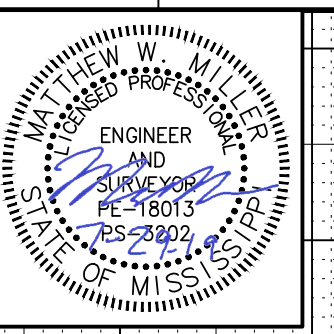

7/30/2019 8:35 AM LAY-HOLMESI.DGN

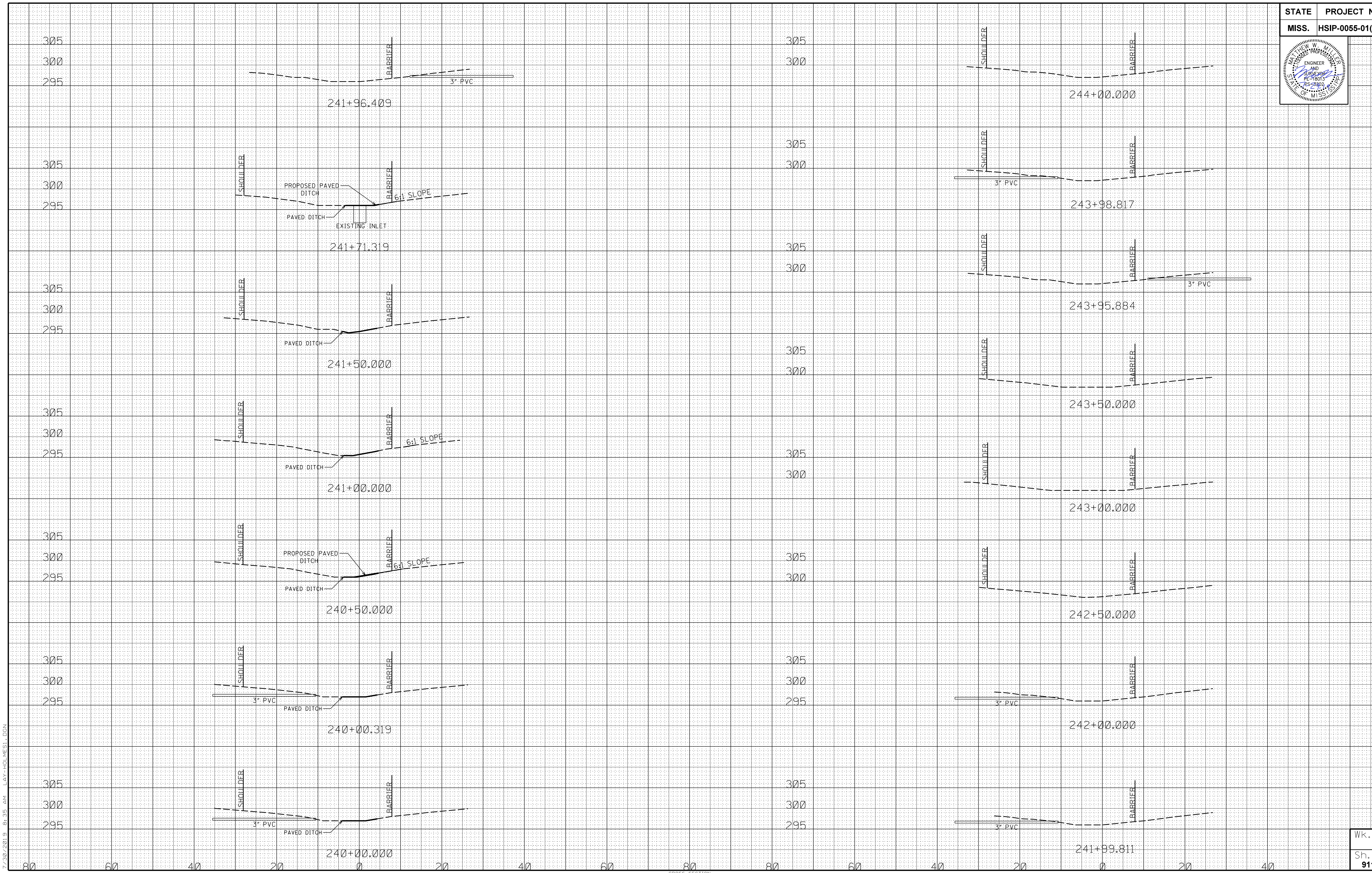
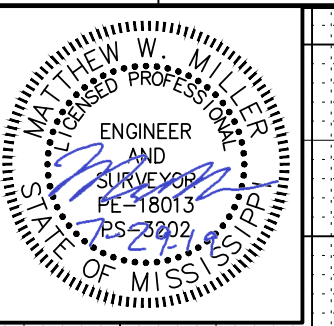

7/30/2019 8:35 AM LAY-HOLMES1.DGN

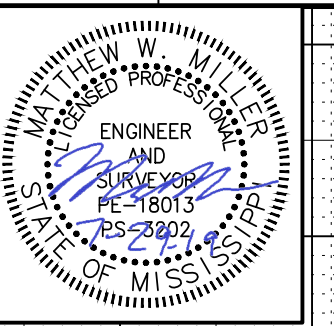

310
305

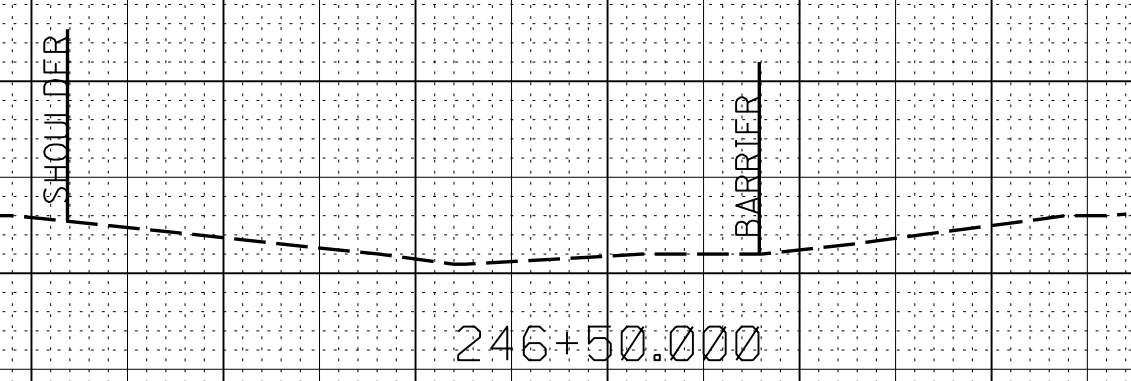

246+50.000

310
305
300

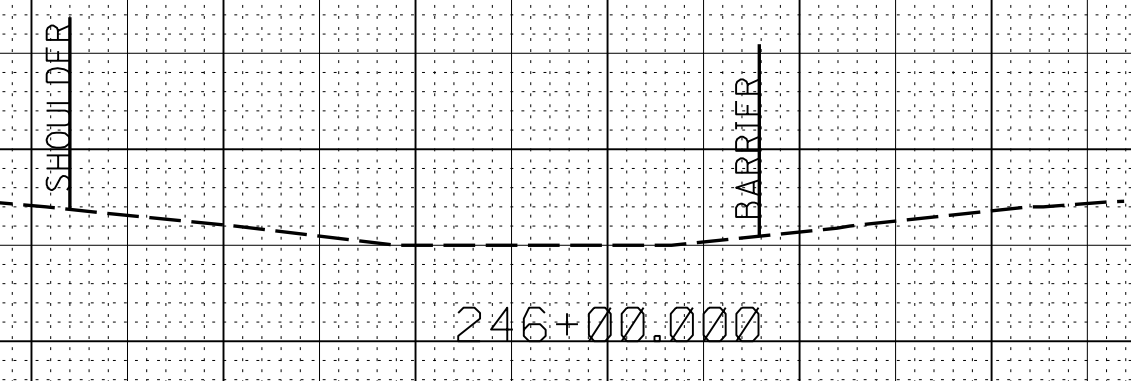

246+00.000

310
305
300

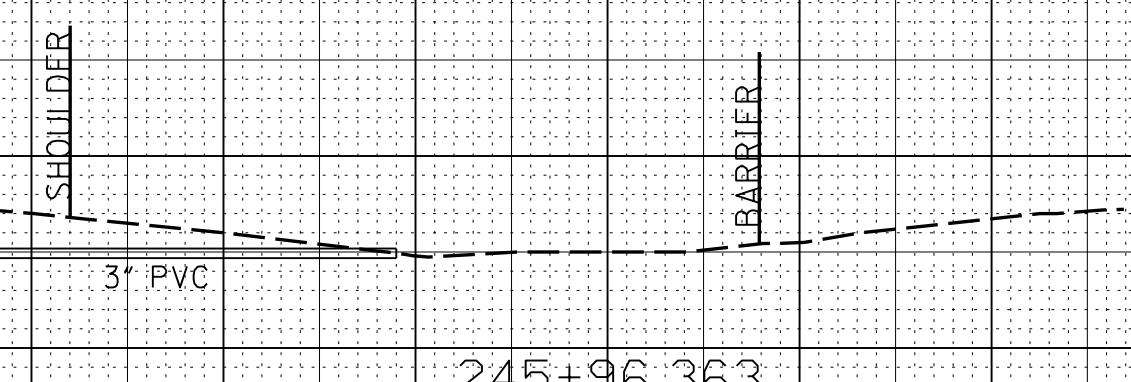

245+96.363

310
305
300

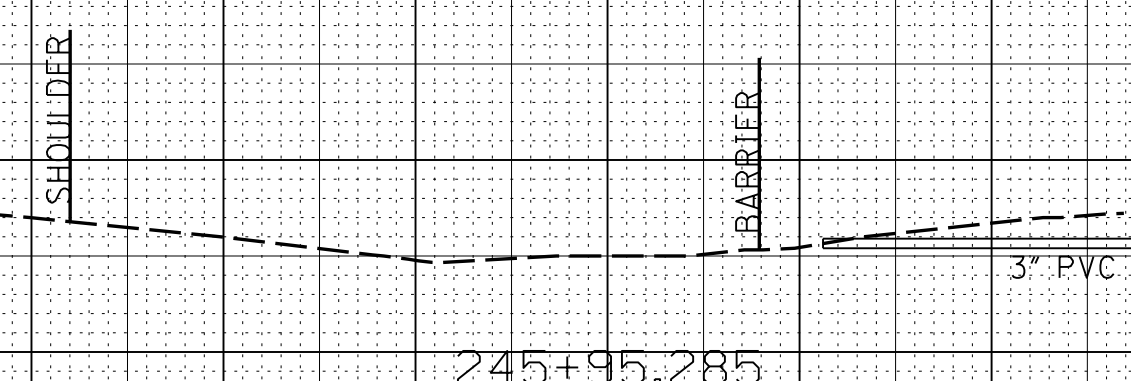

245+95.285

310
305
300

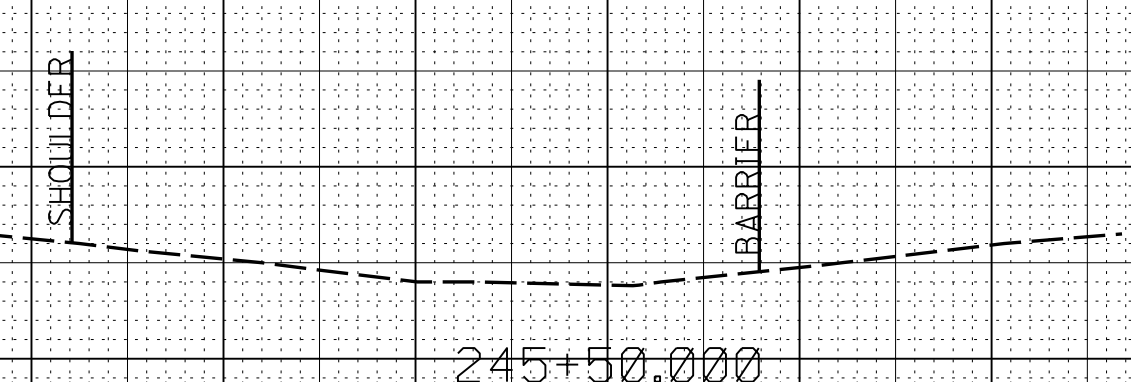

245+50.000

310
305
300

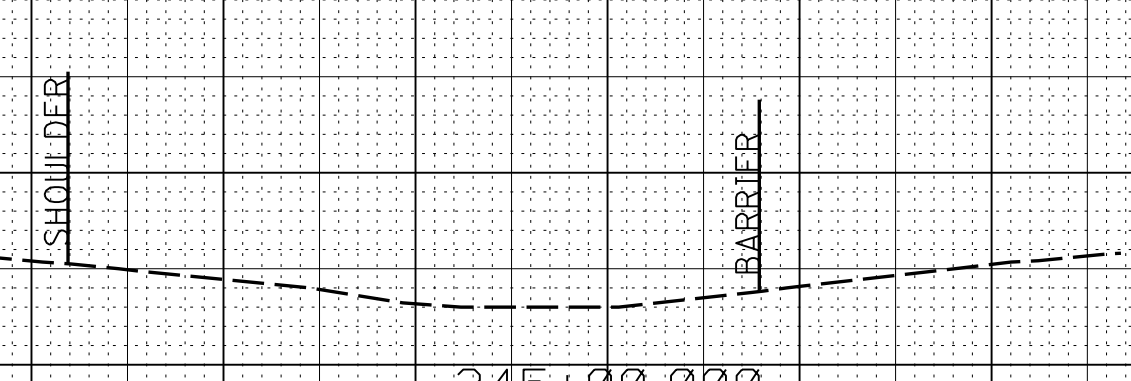

245+00.000

305
300

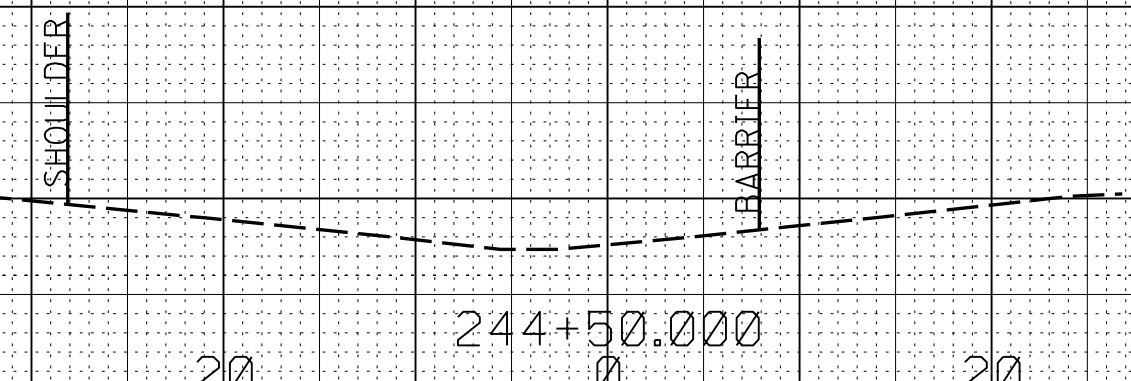

244+50.000

315
310
305

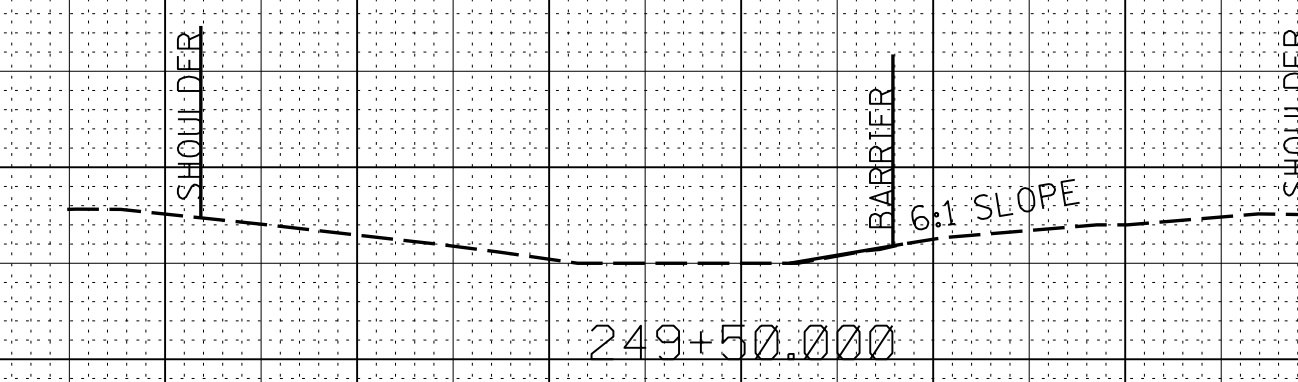

249+50.000

315
310
305



249+00.000

315
310
305

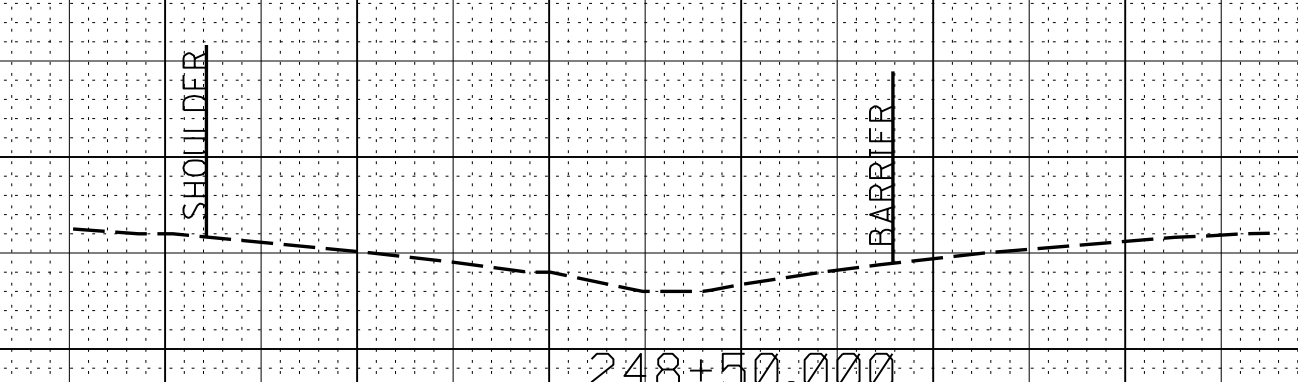

248+50.000

315
310
305

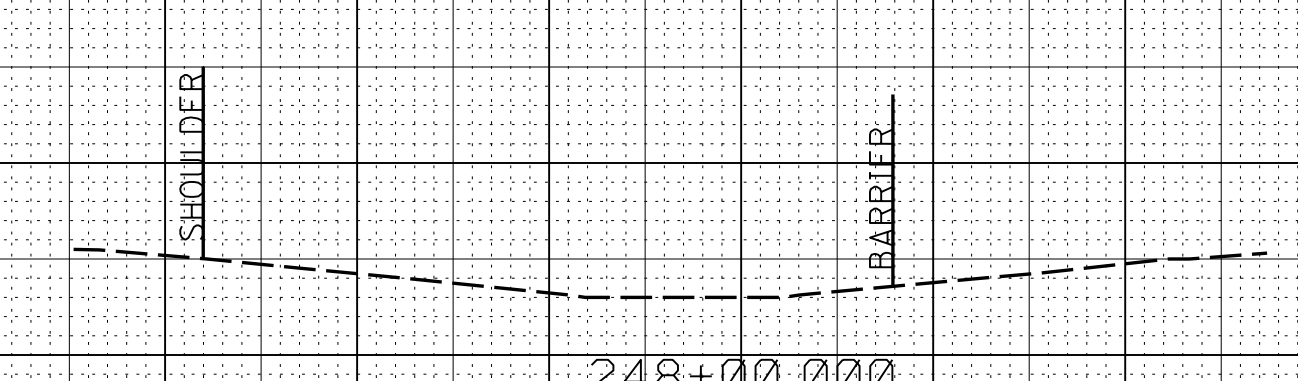

248+00.000

310
305

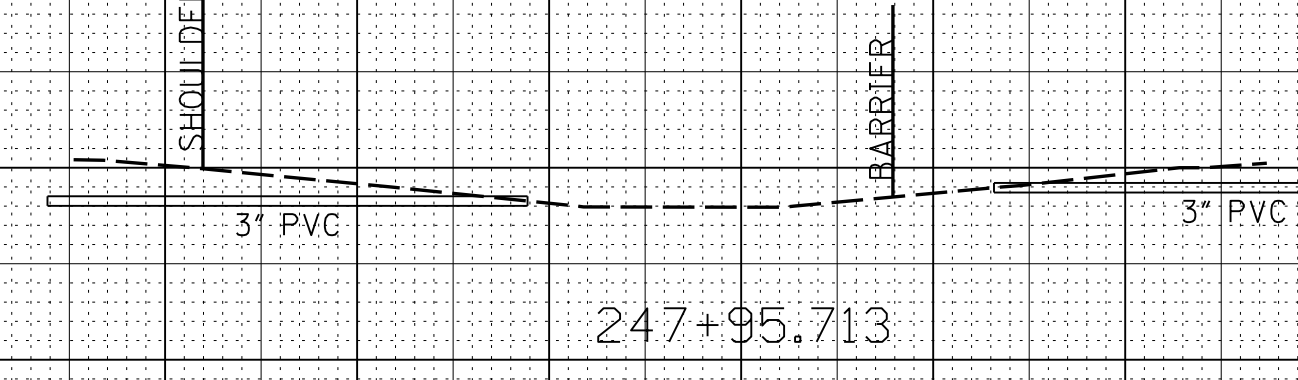

247+95.713

310
305

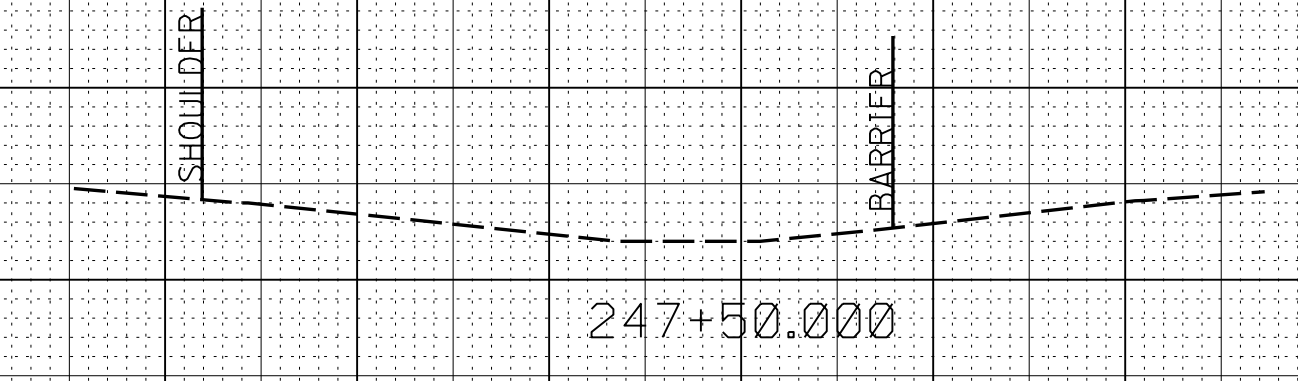

247+50.000

310
305

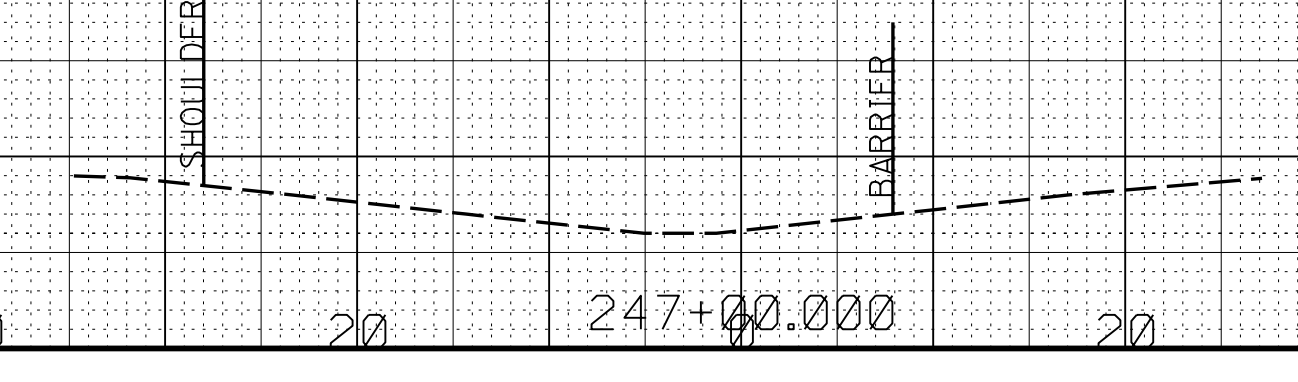

247+00.000

7/30/2019 8:35 AM LAY-HOLMEST.DGN

80 60 40 20 0 20 40 60 80 80 60 40 20 0 20 40

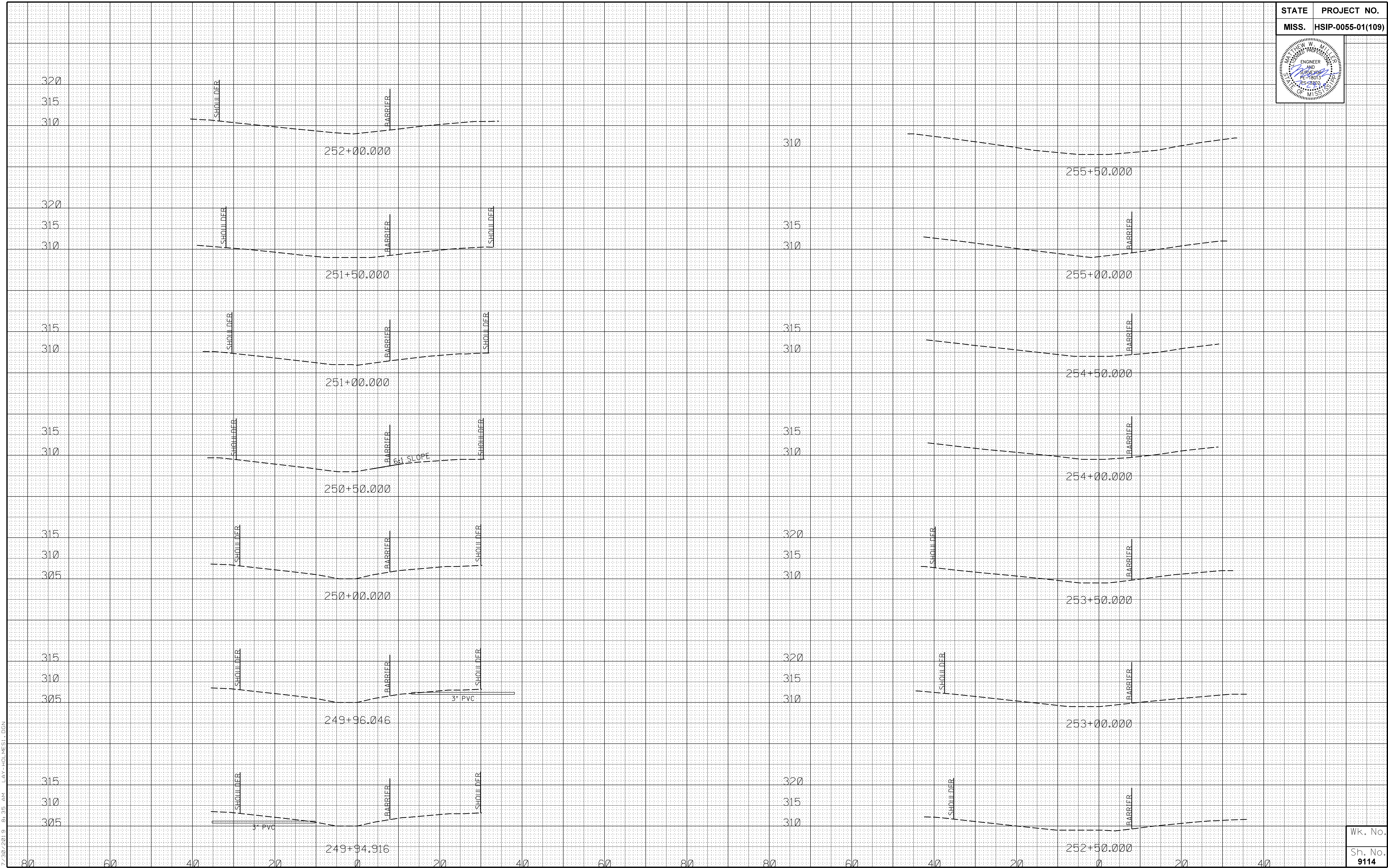
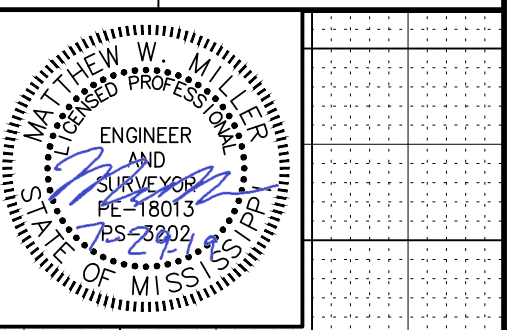

7/30/2019 8:35 AM LAY-HOLMES1.DGN

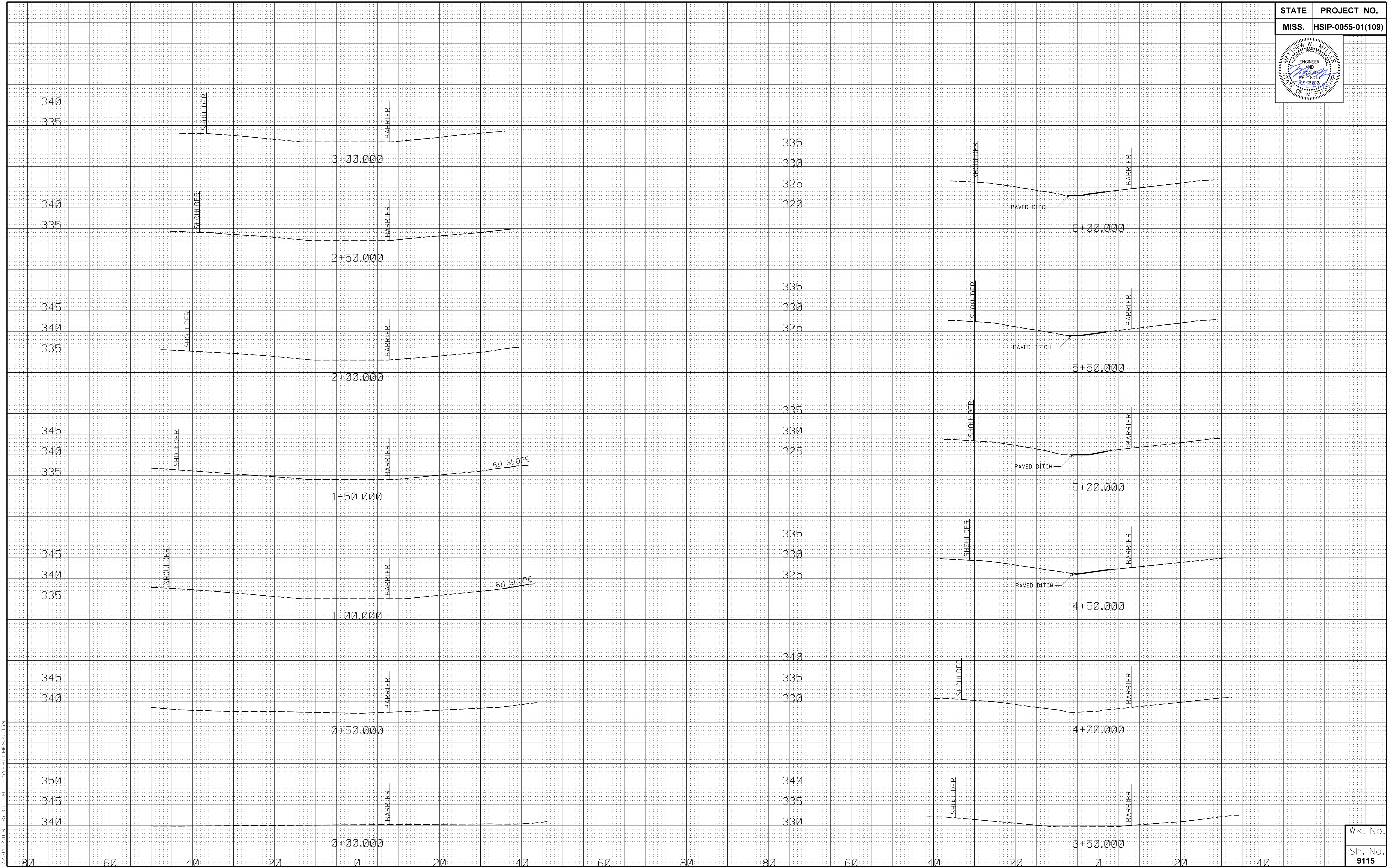
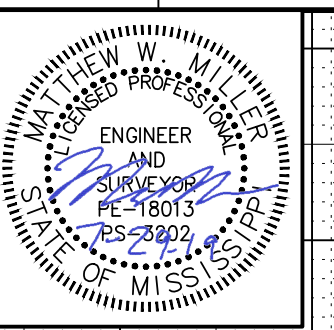

7/30/2019 8:35 AM LAY-HOLMES2.DGN

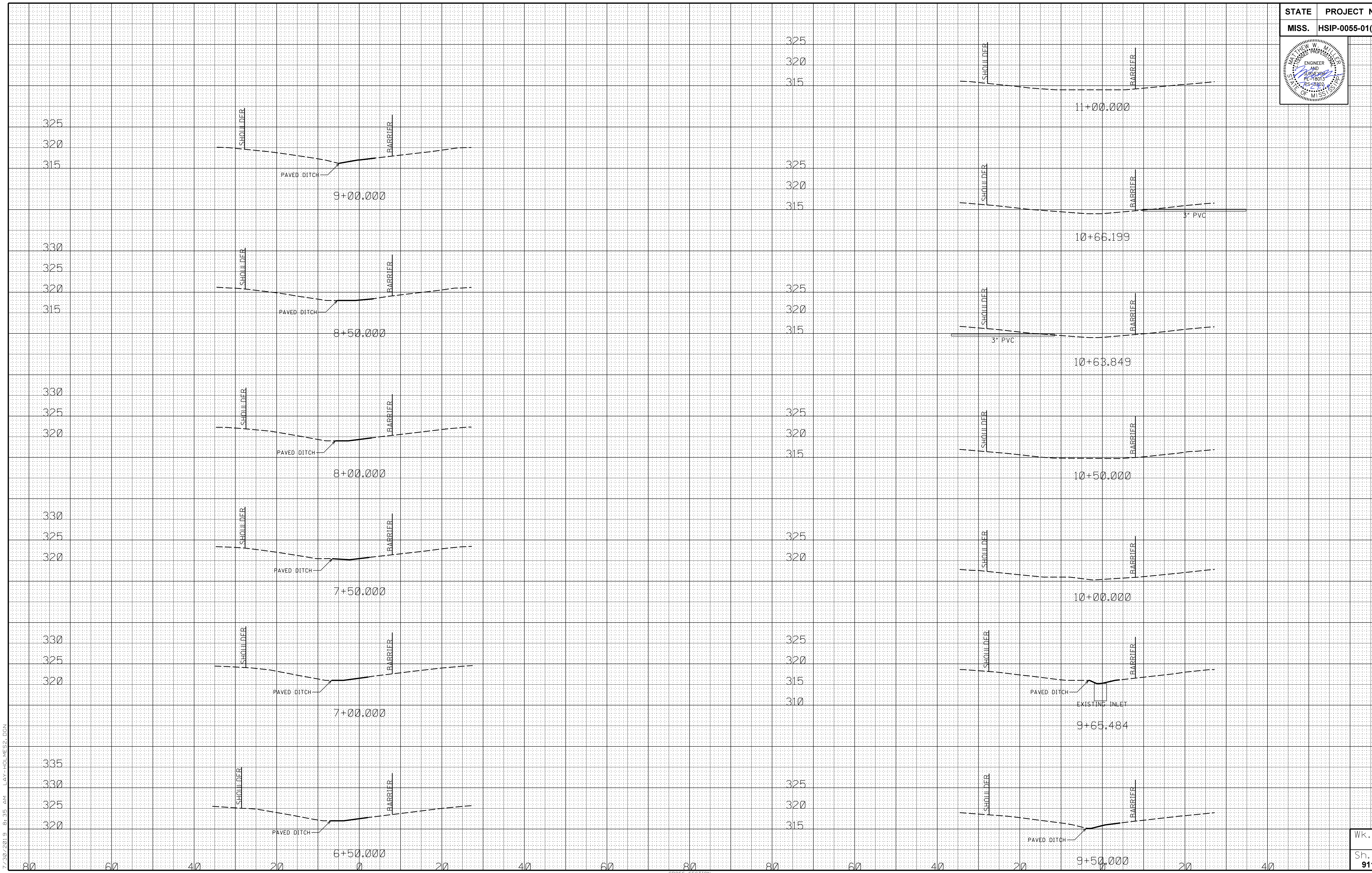
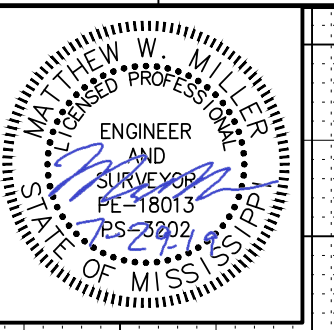

7/30/2019 8:35 AM LAY-HOLMES2.DGN

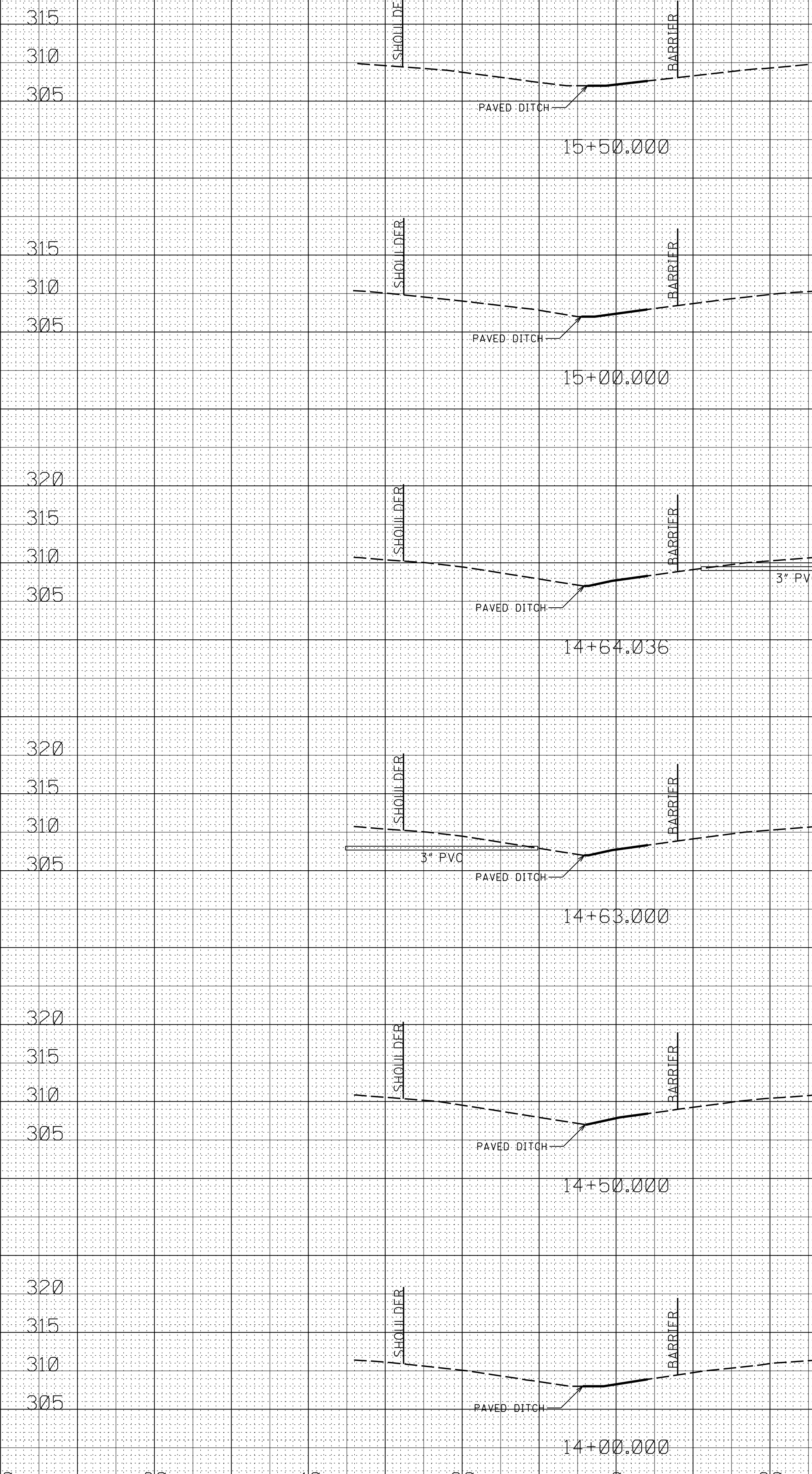
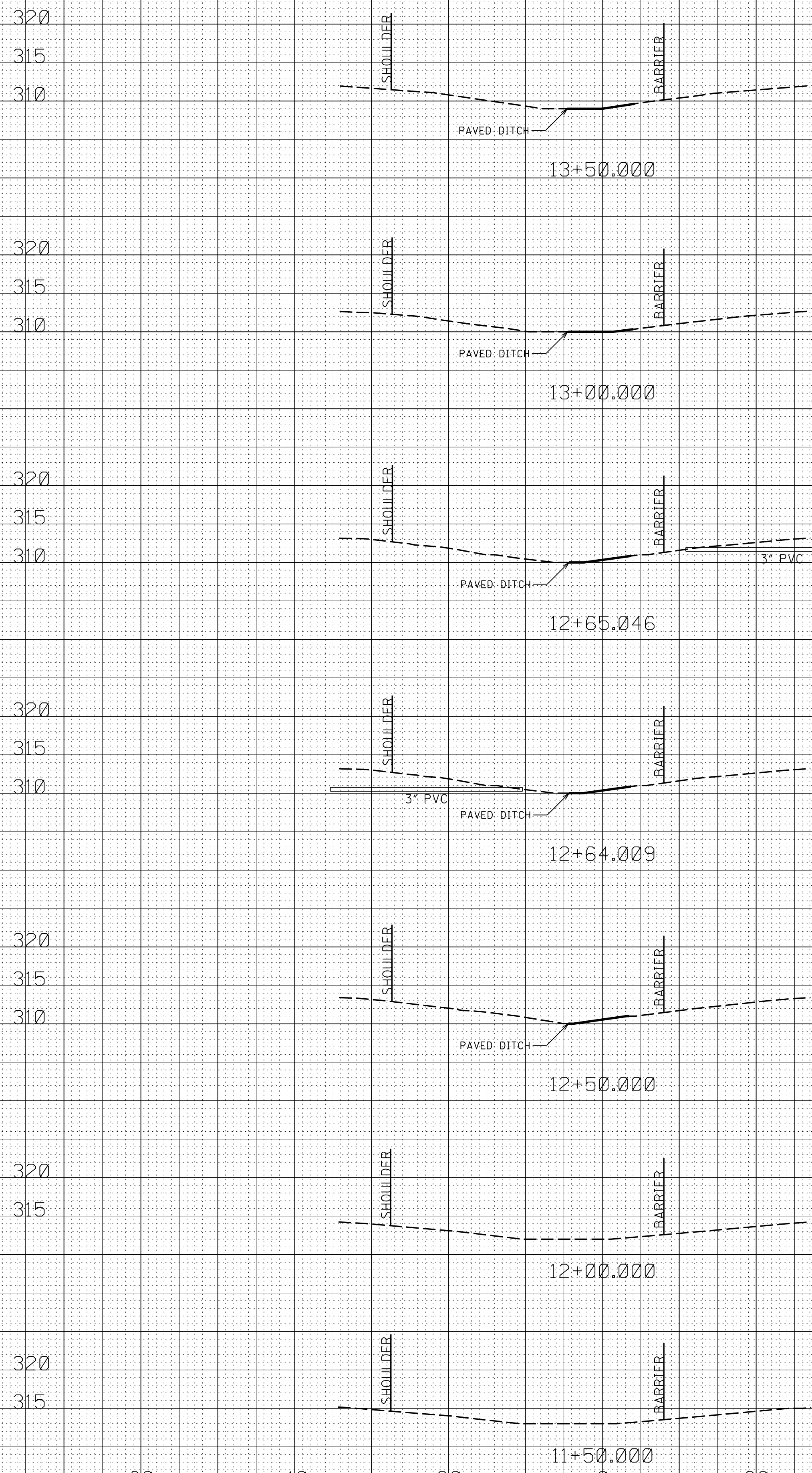
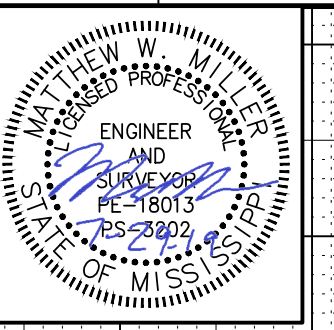

7/30/2019 8:35 AM LAY-HOLMES2.DGN

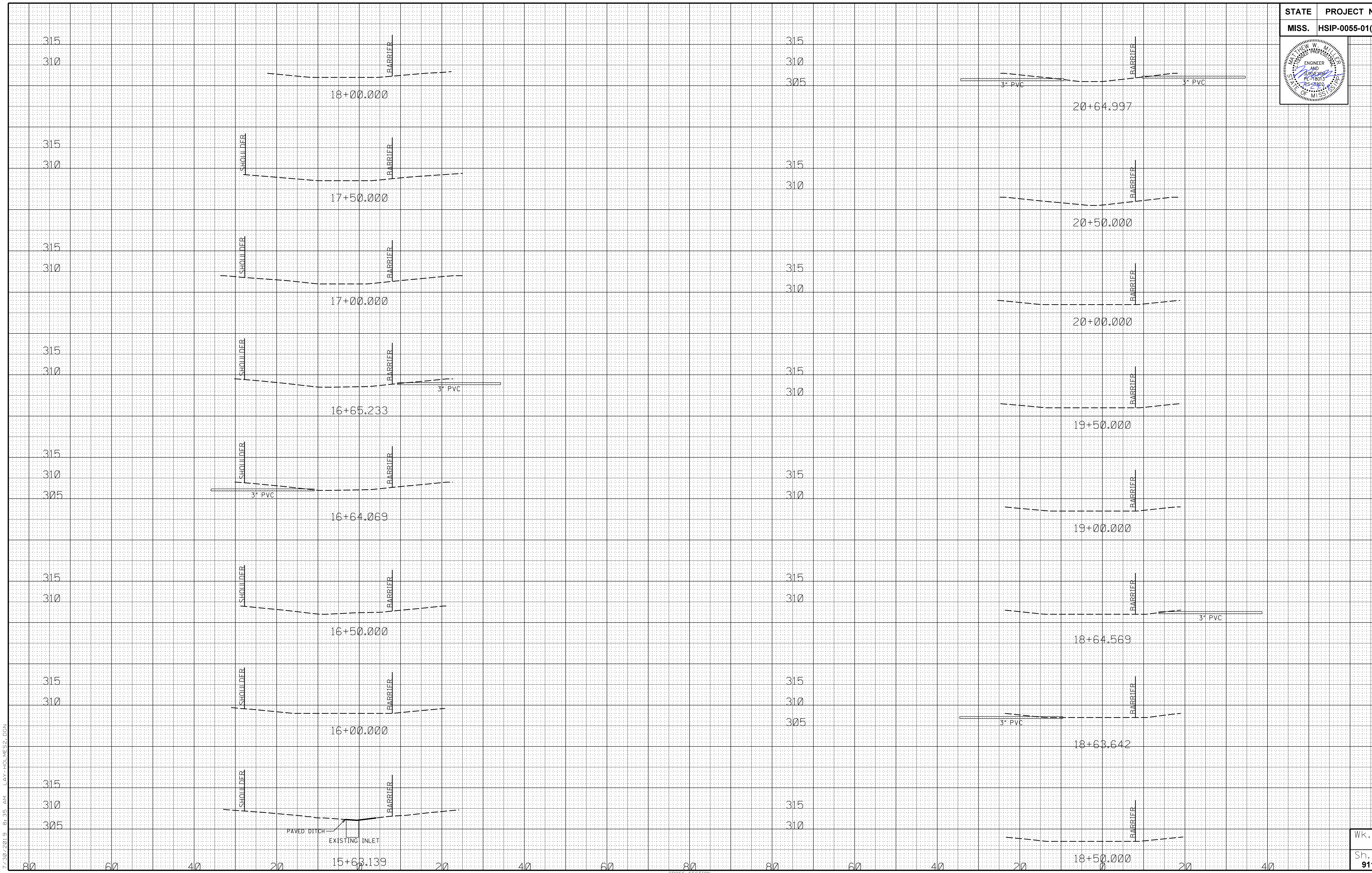
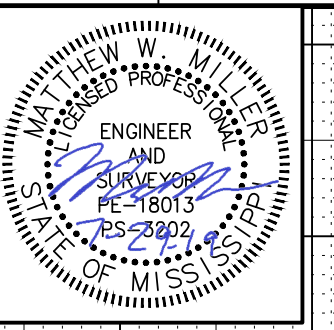

7/30/2019 8:35 AM LAY-HOLMES2.DGN

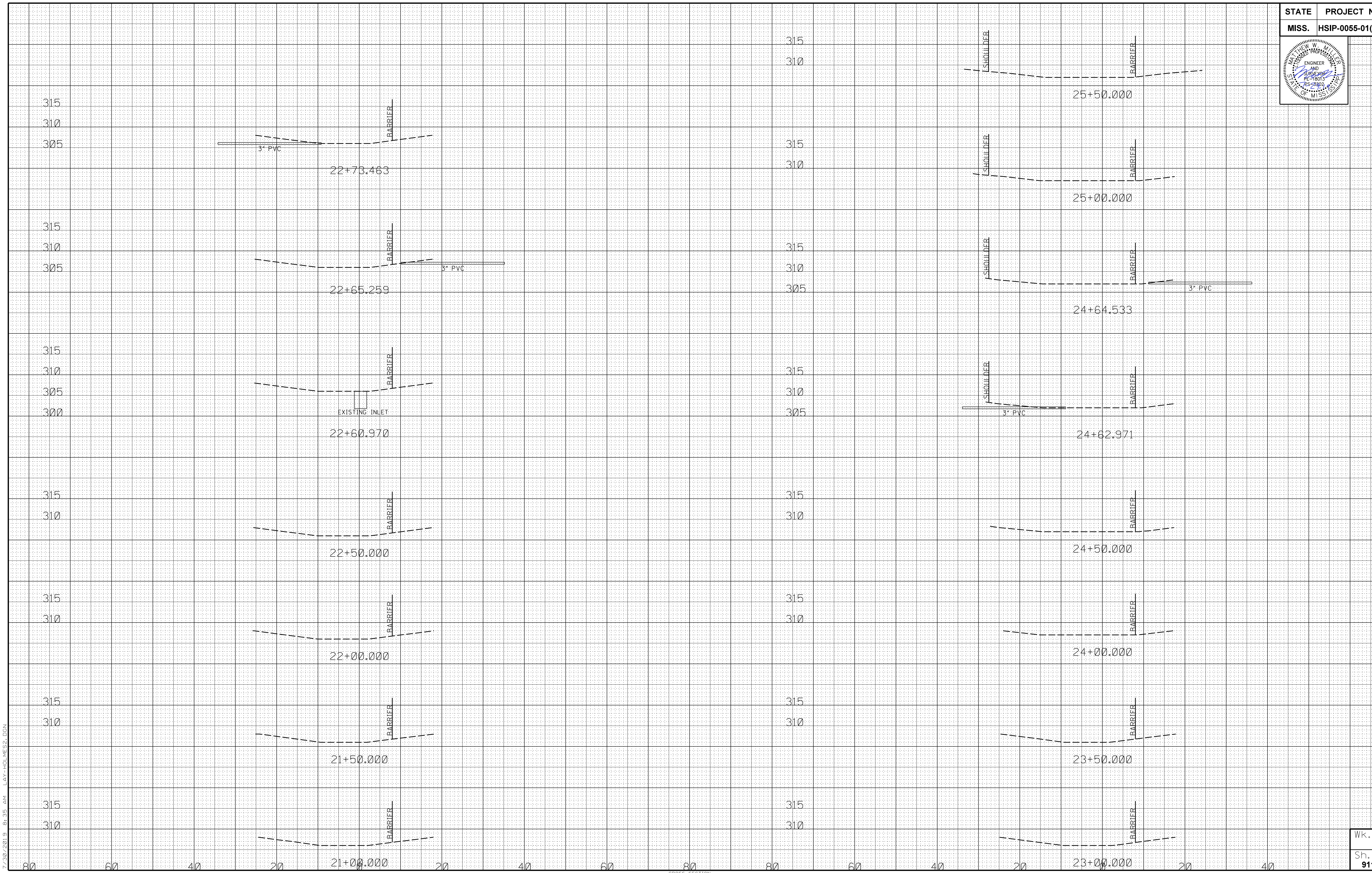
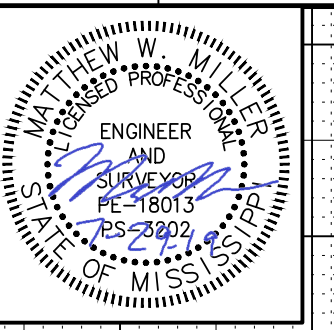

7/30/2019 8:35 AM LAY-HOLMES2.DGN

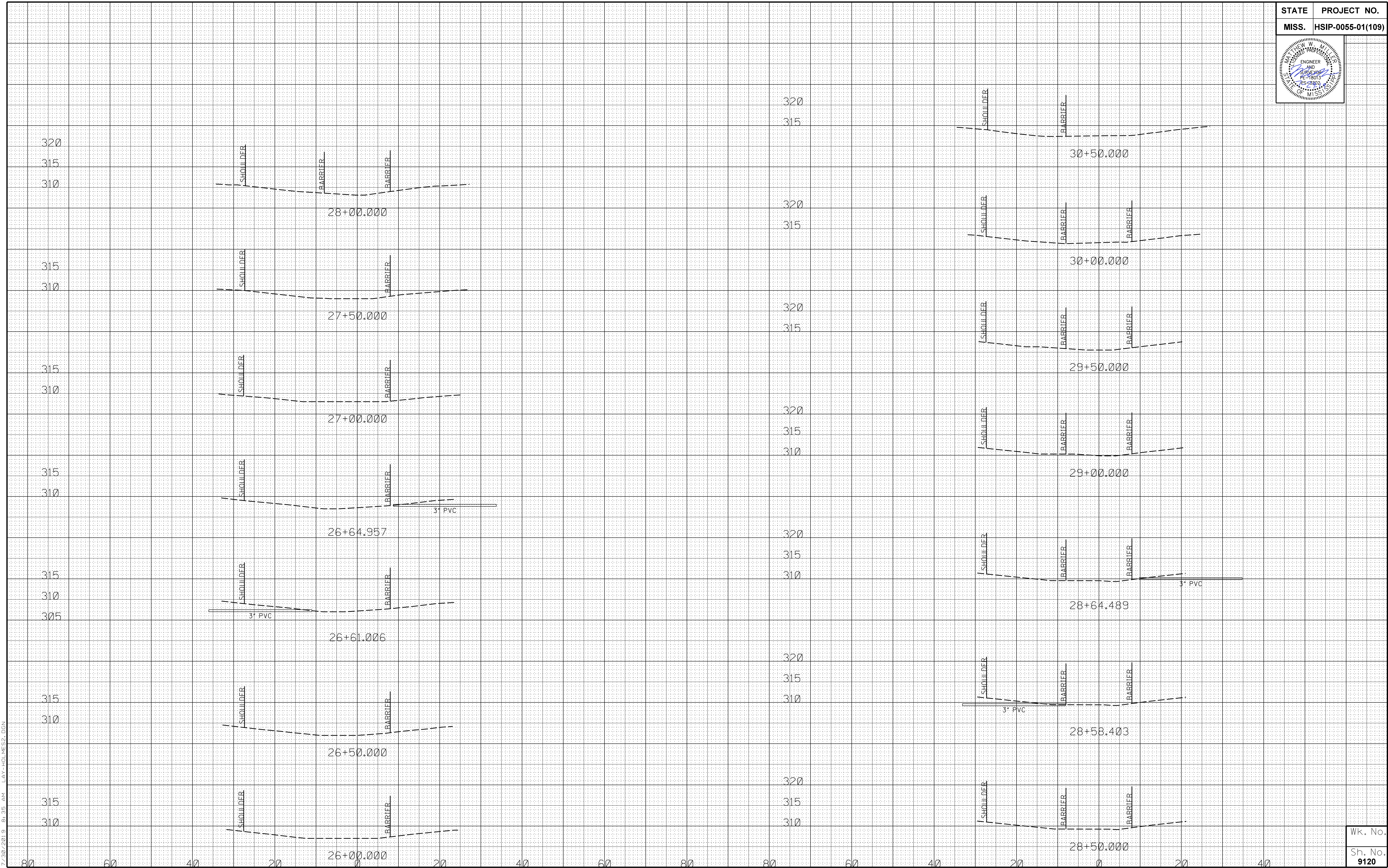
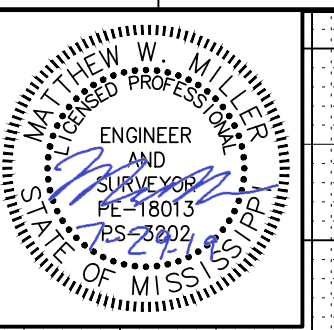

7/30/2019 8:35 AM LAY-HOLMES2.DGN

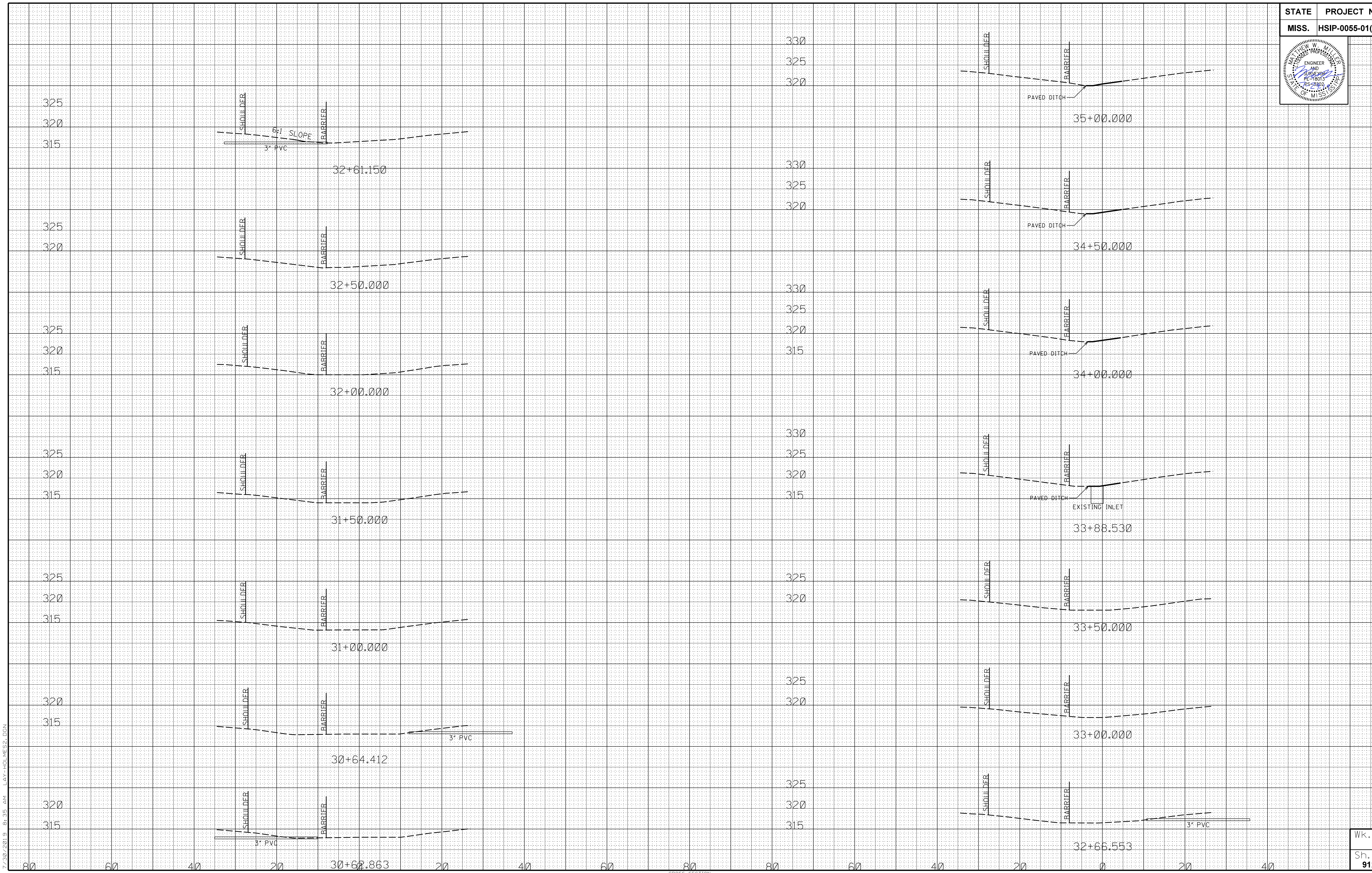
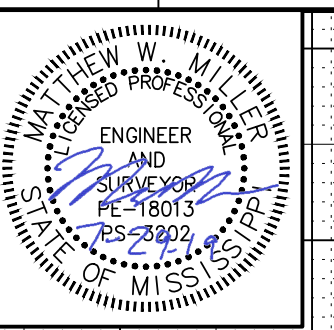

7/30/2019 8:35 AM LAY-HOLMES2.DGN

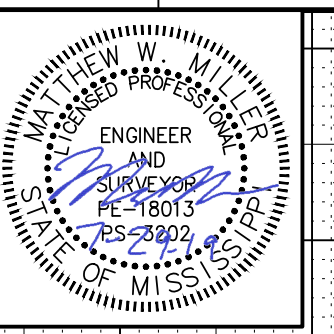

340
335
330
325

335
330

335
330

335
330

335
330
325

335
330
325

330
325
320



345
340
335
330

340
335
330

340
335
330

340
335
330

340
335
330

340
335
330
325

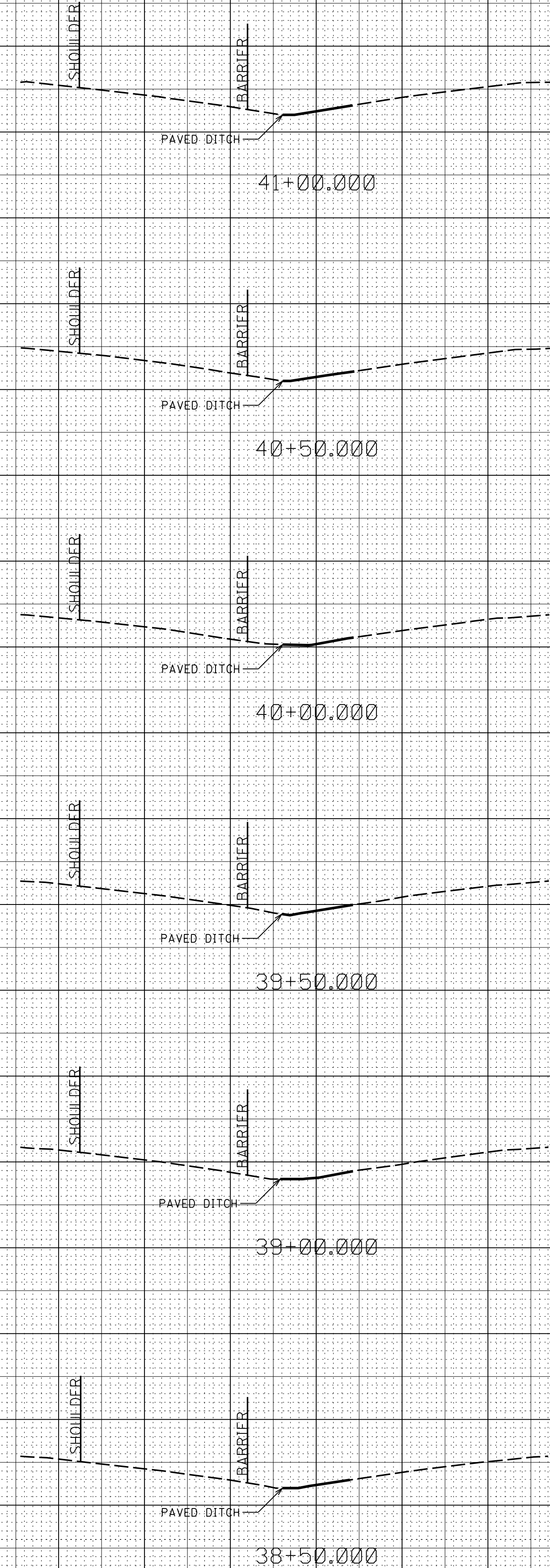

7/30/2019 8:35 AM LAY-HOLMES2.DGN

80 60 40 20 0 20 40 60 80 80 60 40 20 0 20 40

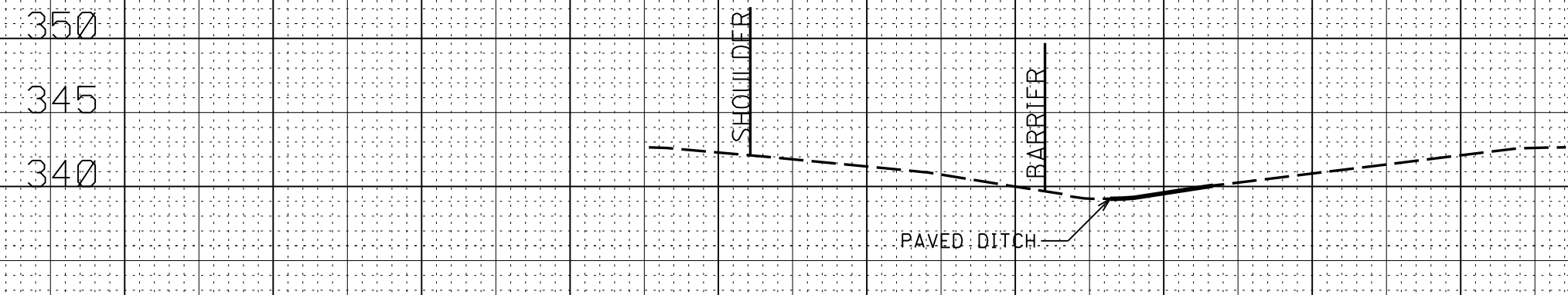
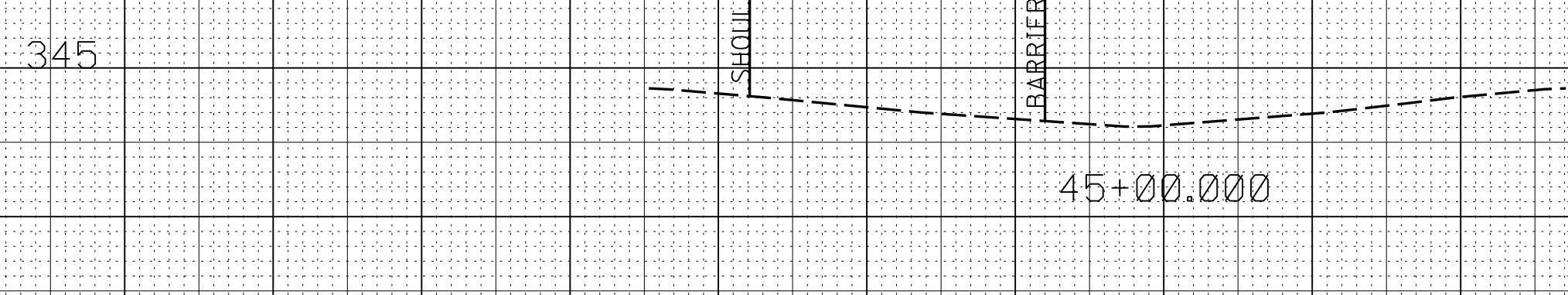
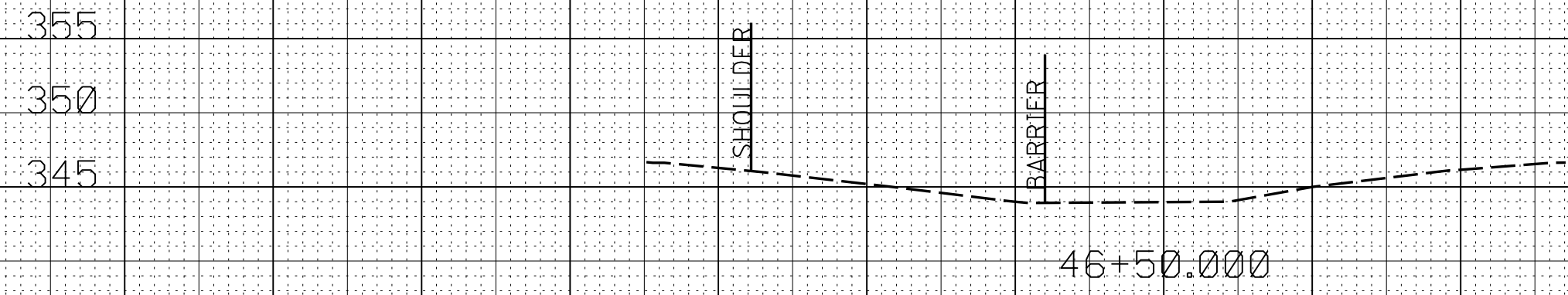
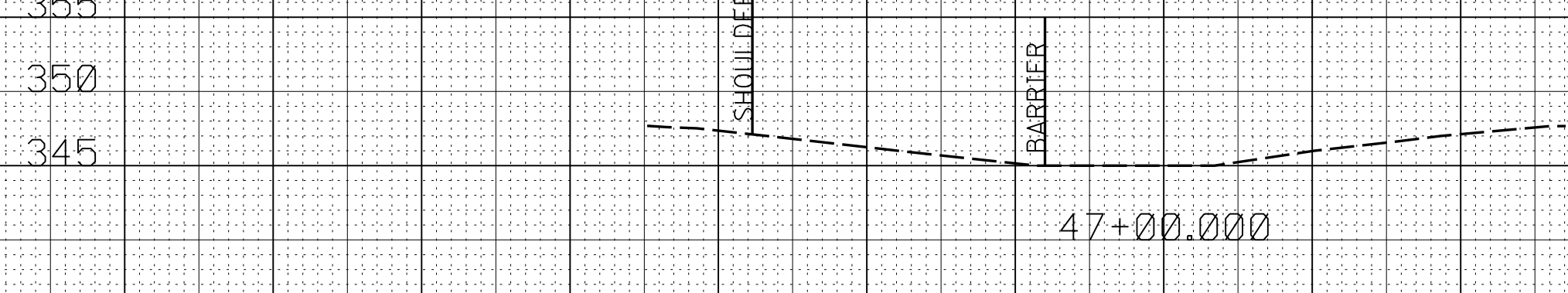
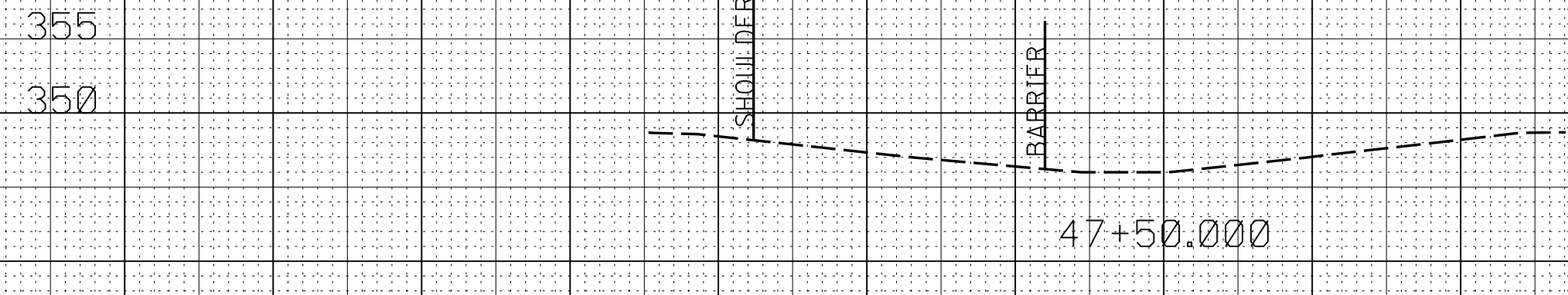
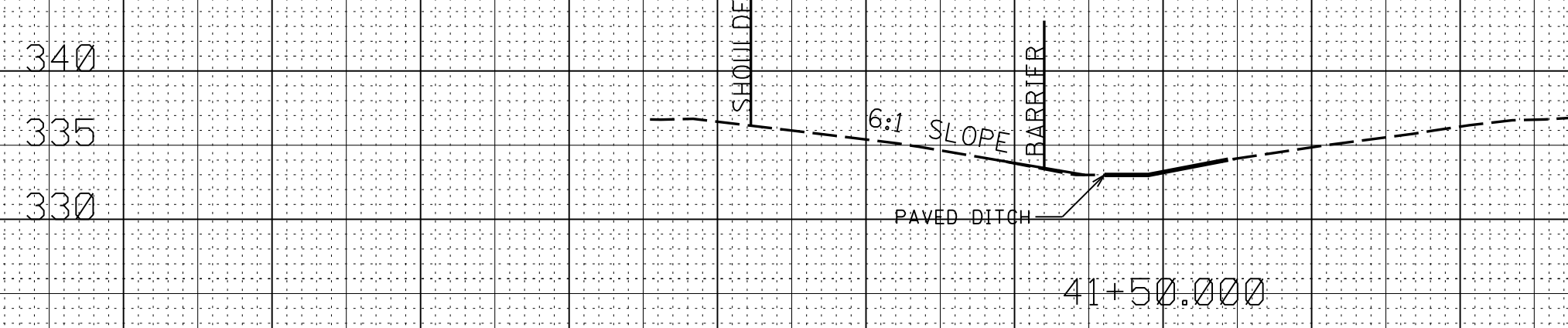
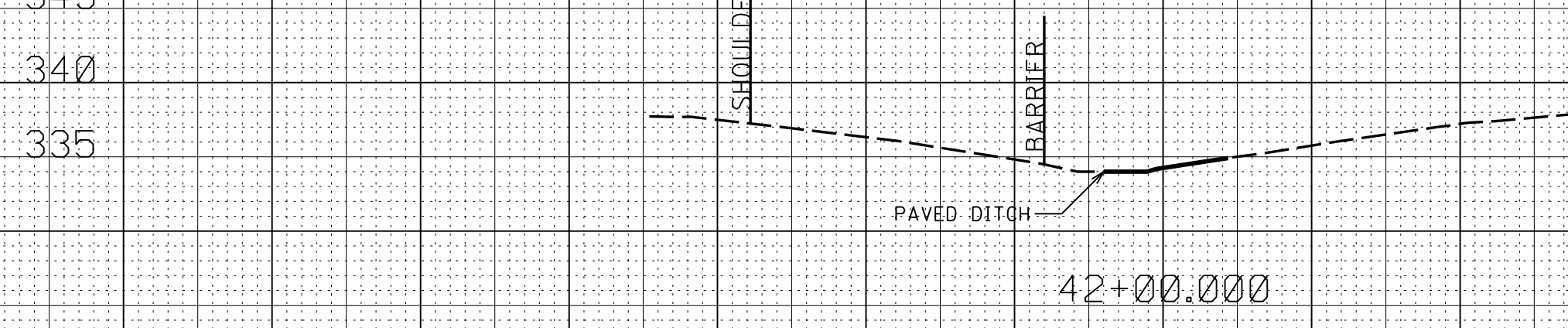
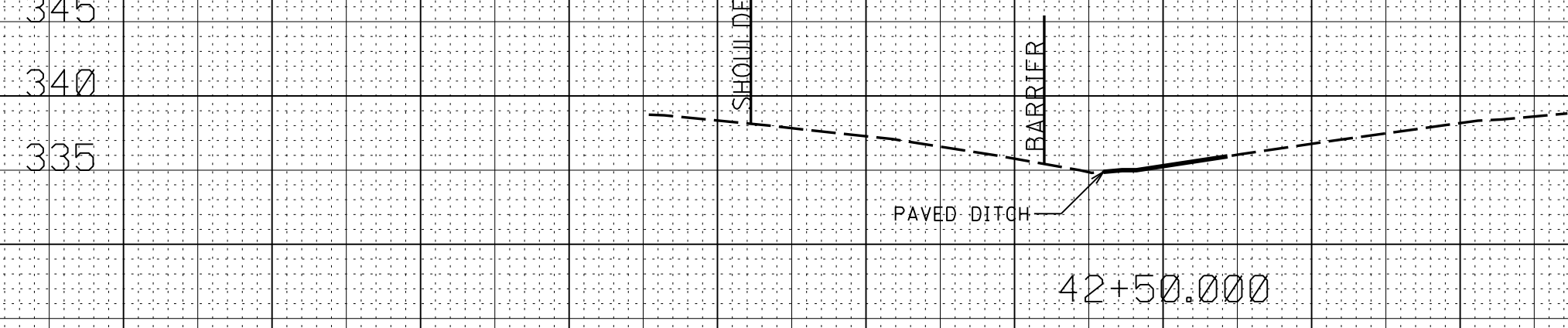
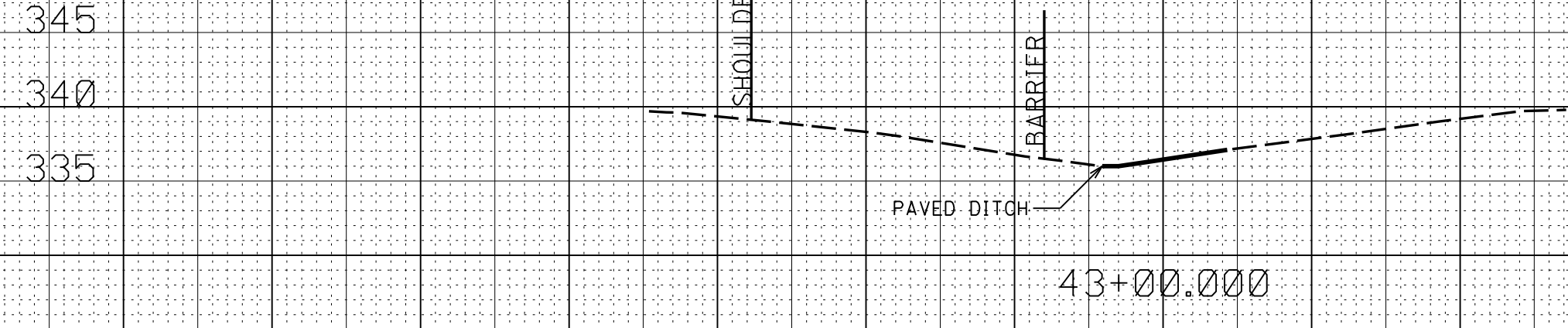
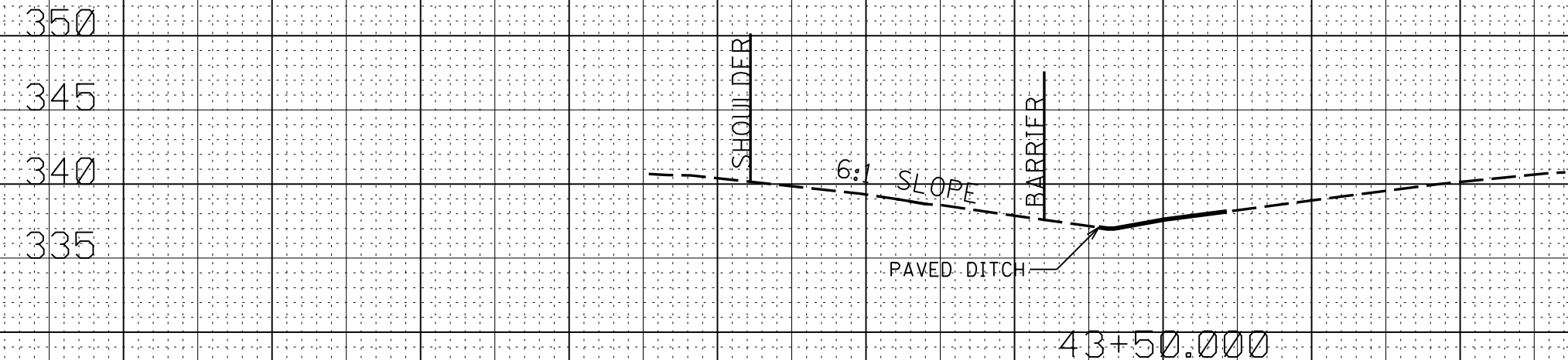
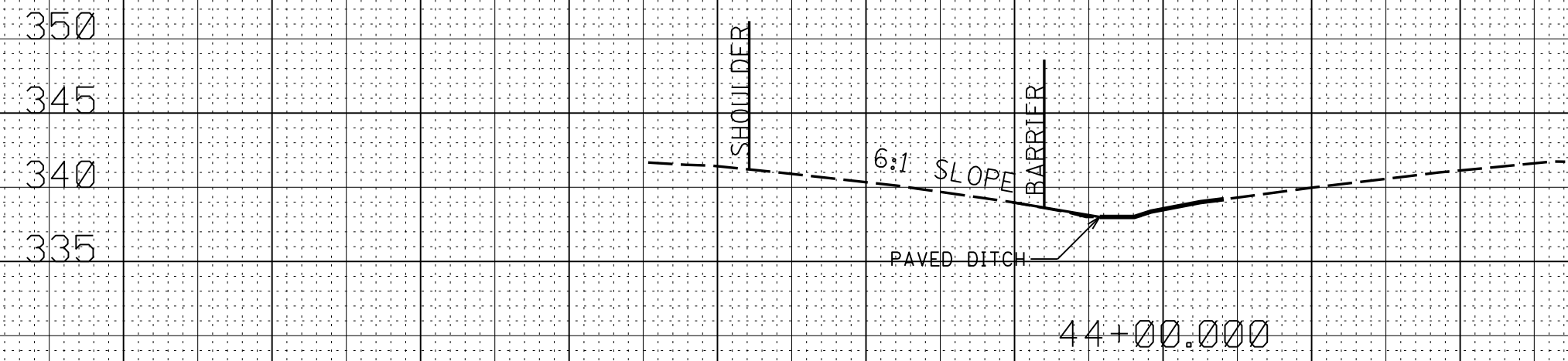
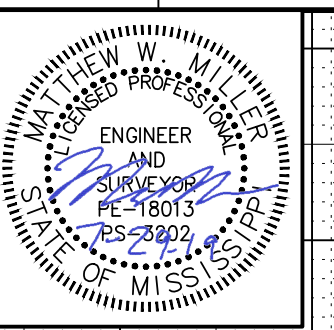

7/30/2019 8:35 AM LAY-HOLMES2.DGN

80 60 40 20 0 20 40 60 80 80 60 40 20 44+50.000 20 40

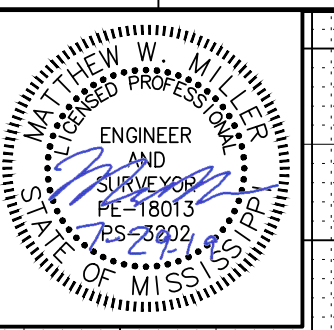

7/26/2019 8:35 AM LAY-HOLMES2.DGN

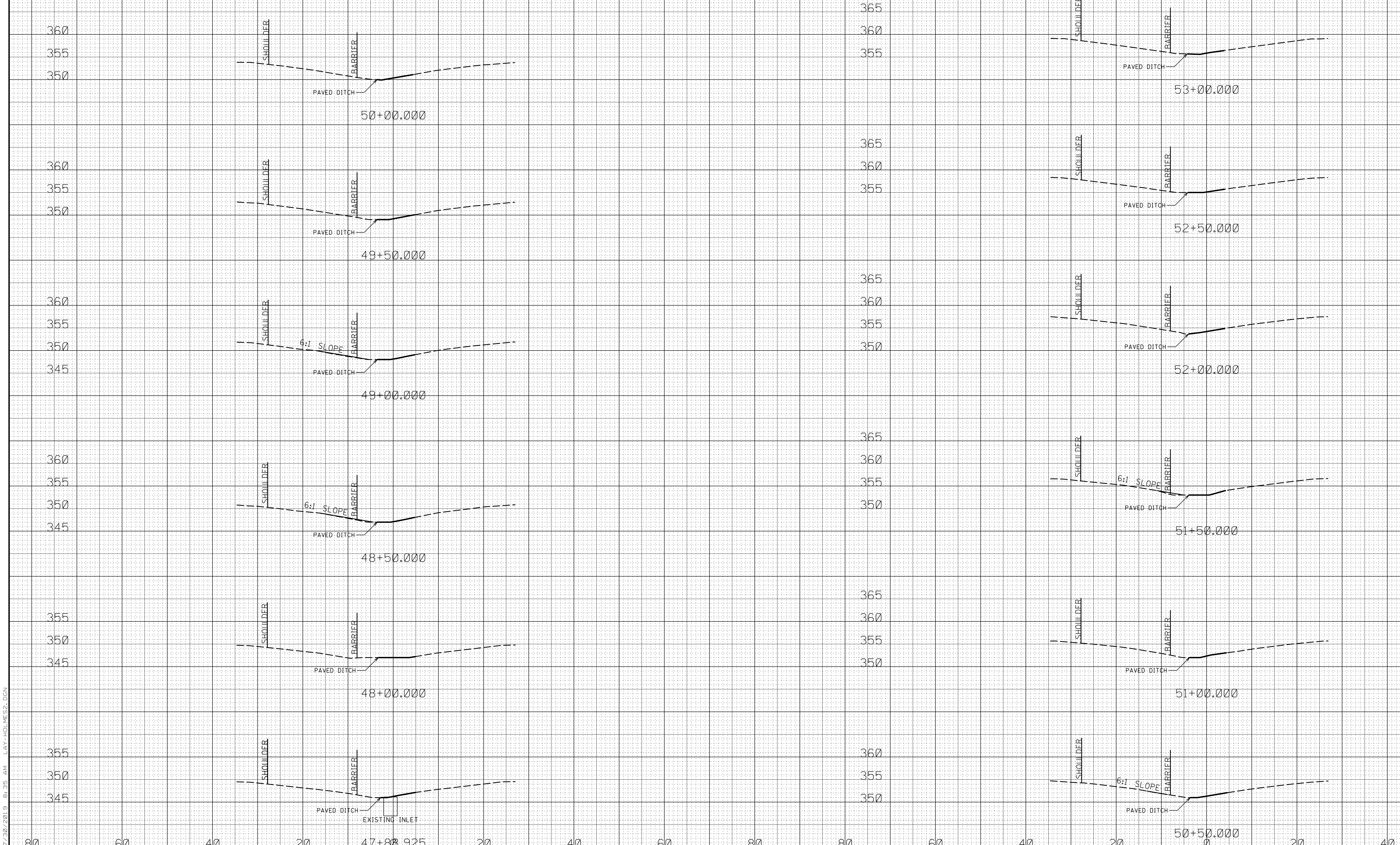

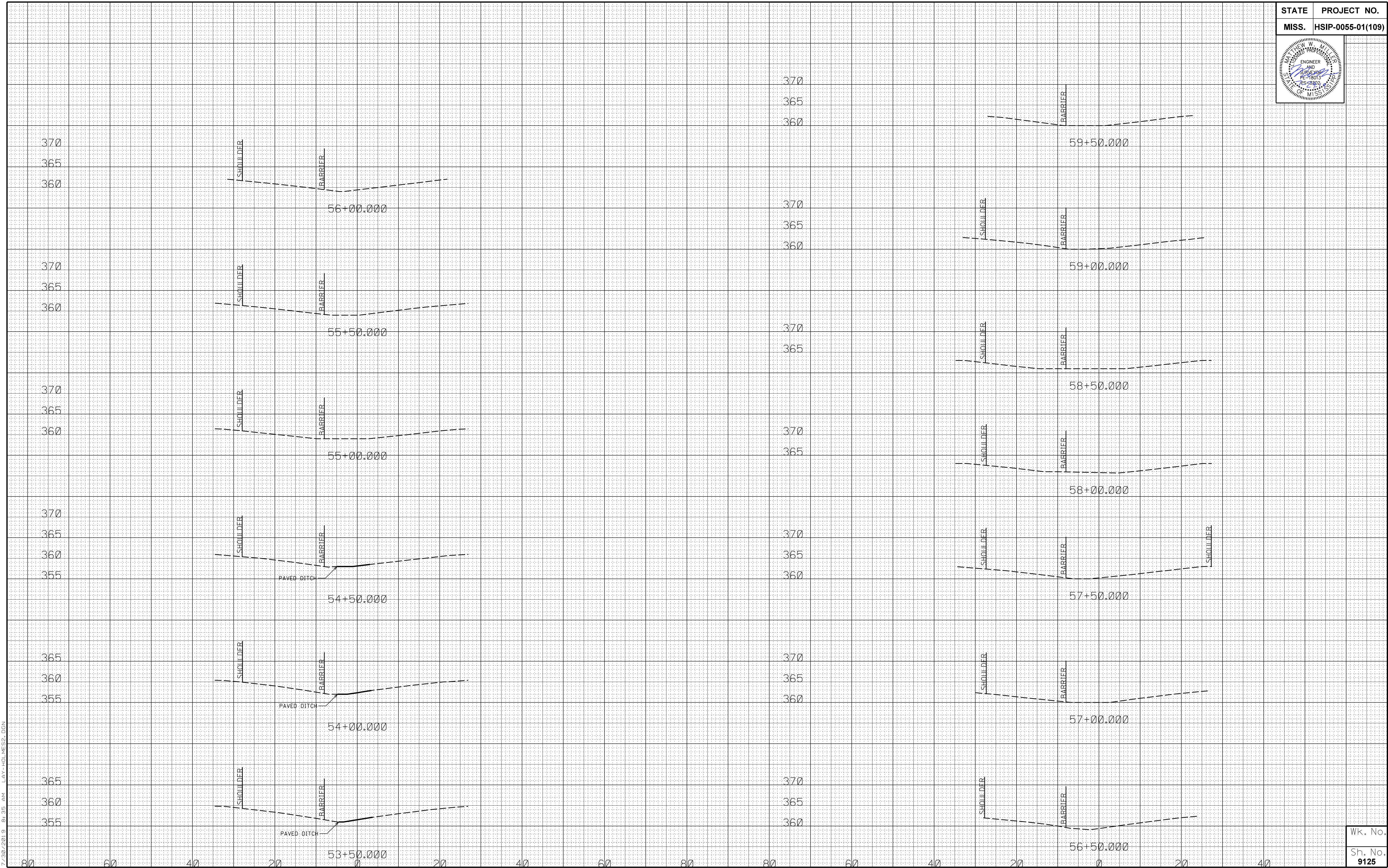
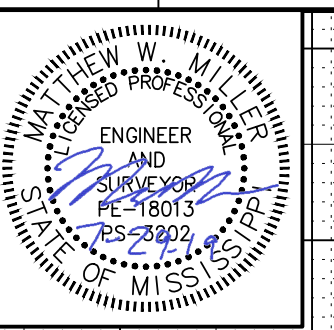

7/30/2019 8:35 AM LAY-HOLMES2.DGN

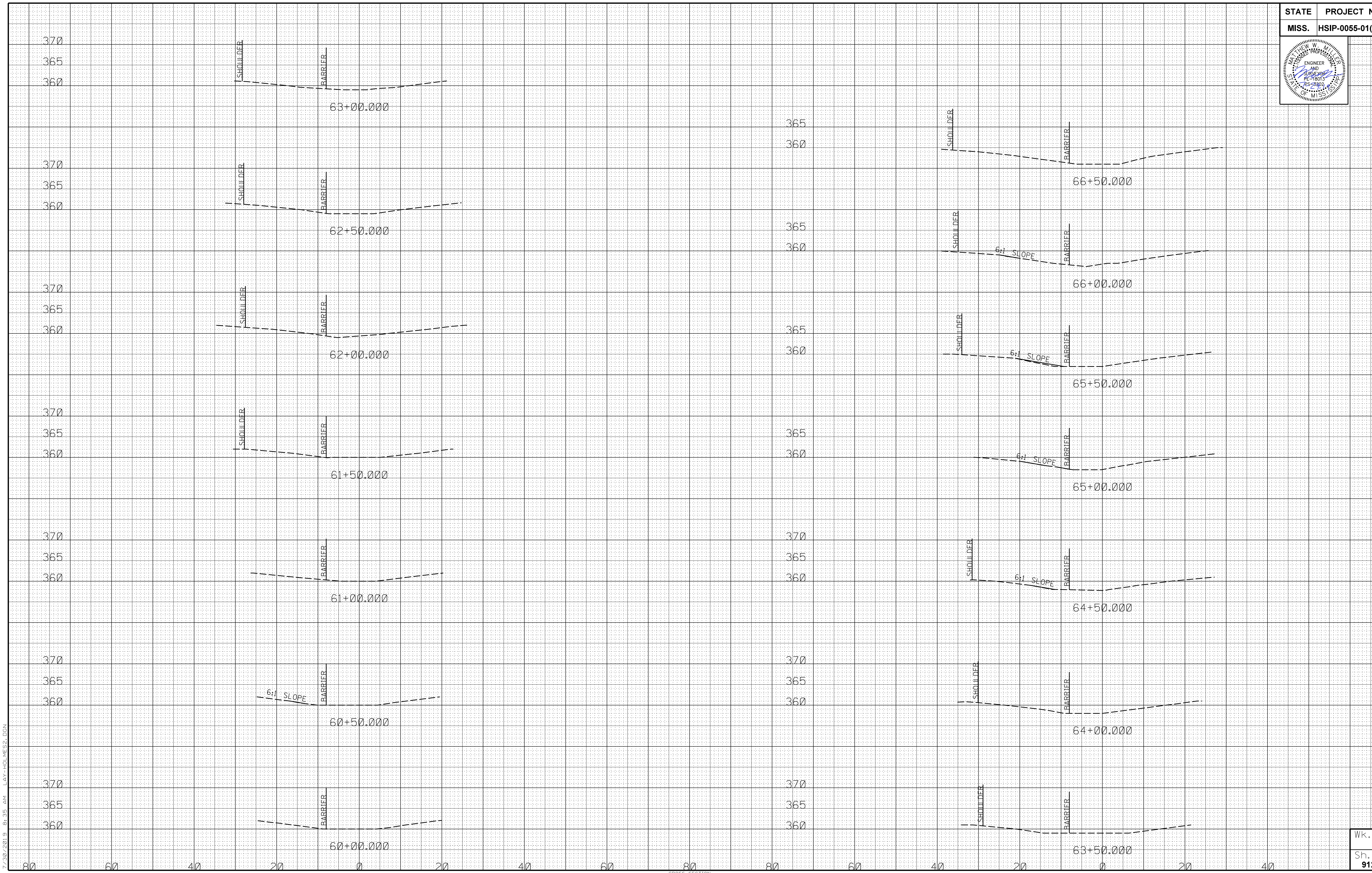
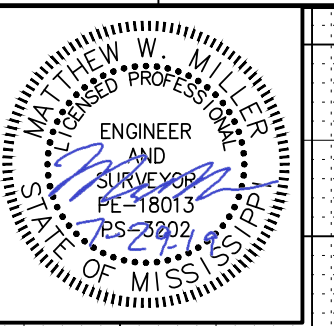

7/30/2019 8:35 AM LAY-HOLMES2.DGN

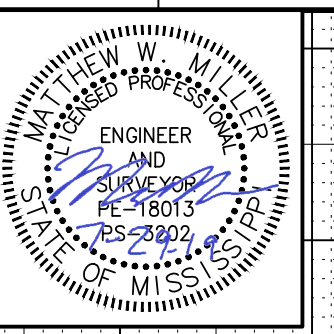

365
360
355

SHOULDER

BARRIER

69+50.000

365
360
355

BARRIER

69+00.000

365
360
355

SHOULDER

BARRIER

68+50.000

365
360

SHOULDER

BARRIER

68+00.000

365
360
355

SHOULDER

BARRIER

71+50.000

365
360

SHOULDER

BARRIER

67+50.000

365
360
355

SHOULDER

BARRIER

71+00.000

365
360

SHOULDER

BARRIER

67+00.000

365
360
355

SHOULDER

BARRIER

70+50.000

365
360
355
350

SHOULDER

BARRIER

EXISTING INLET
66+57.925

365
360
355

SHOULDER

BARRIER

70+00.000

80 60 40 20 0 20 40 60 80 80 60 40 20 0 20 40

7/30/2019 8:35 AM LAY-HOLMES2.DGN

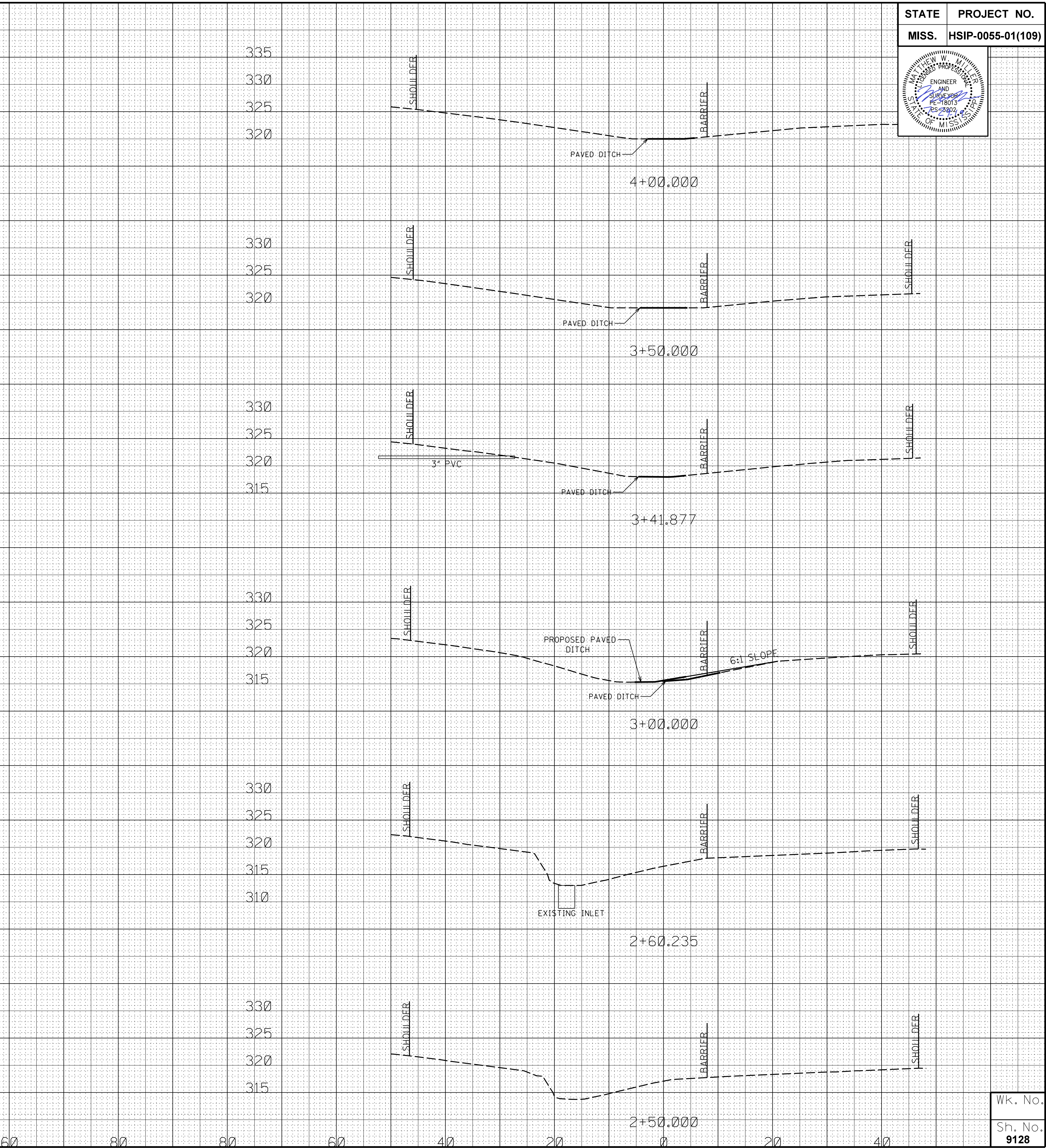
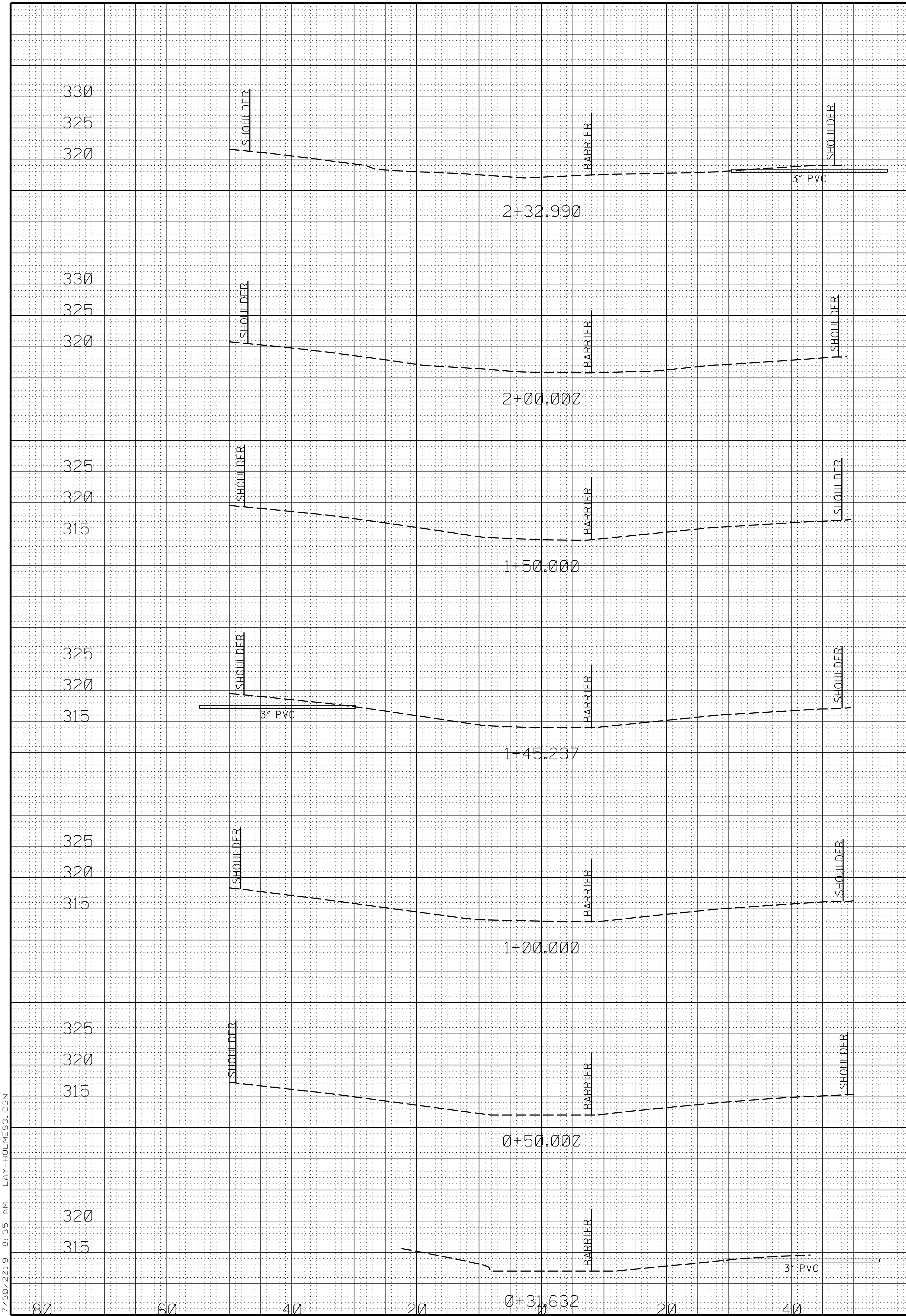
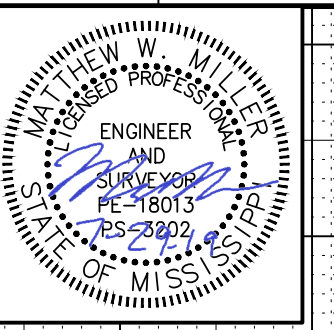

7/20/2019 8:35 AM LAY-HOLMES3.DGN

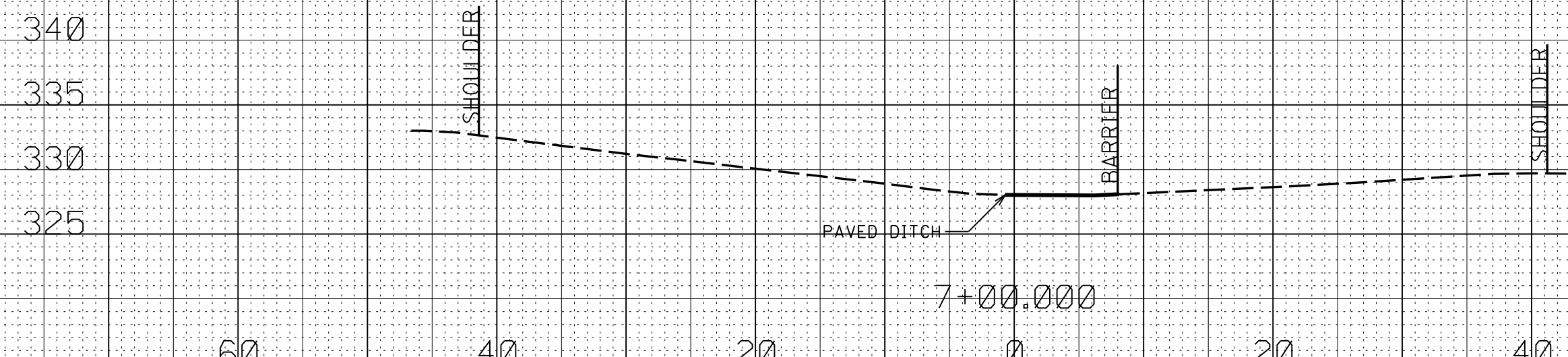
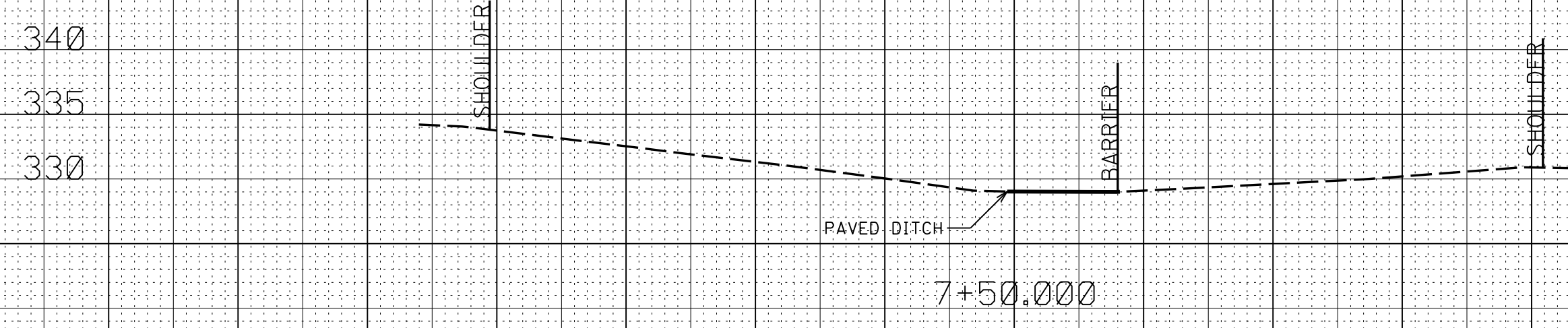
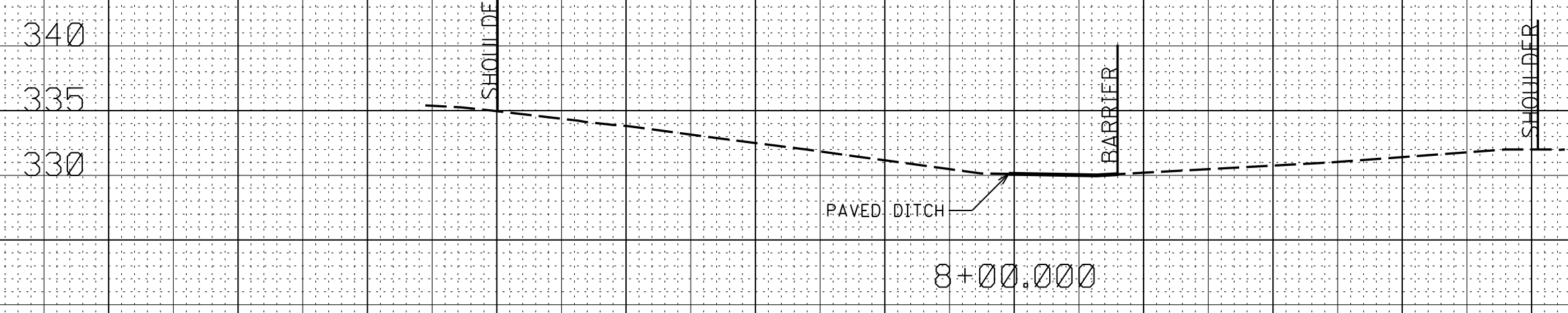
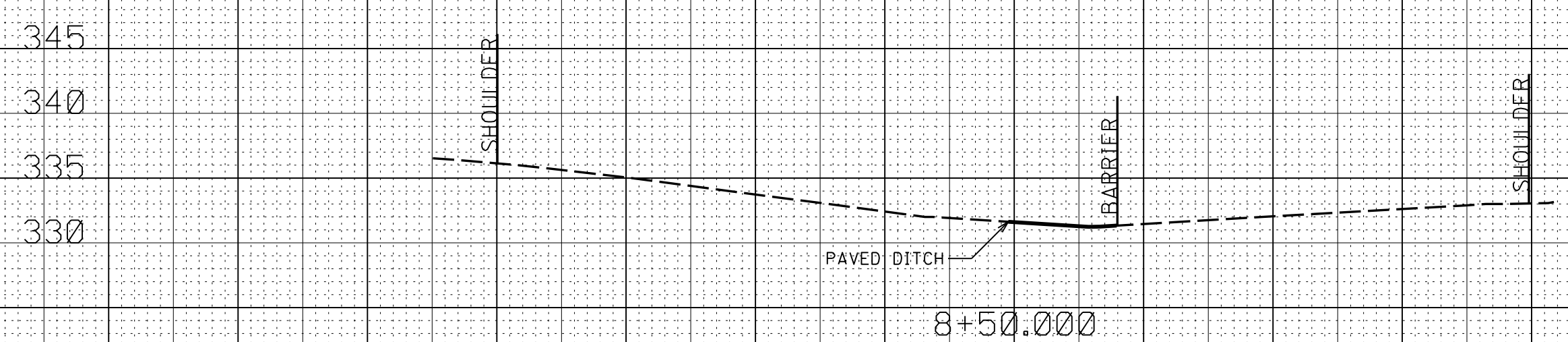
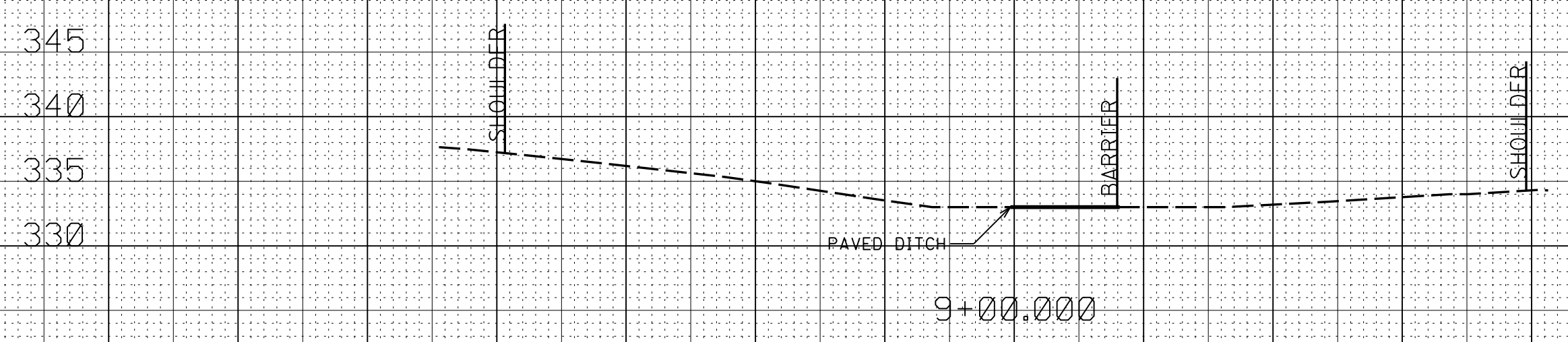
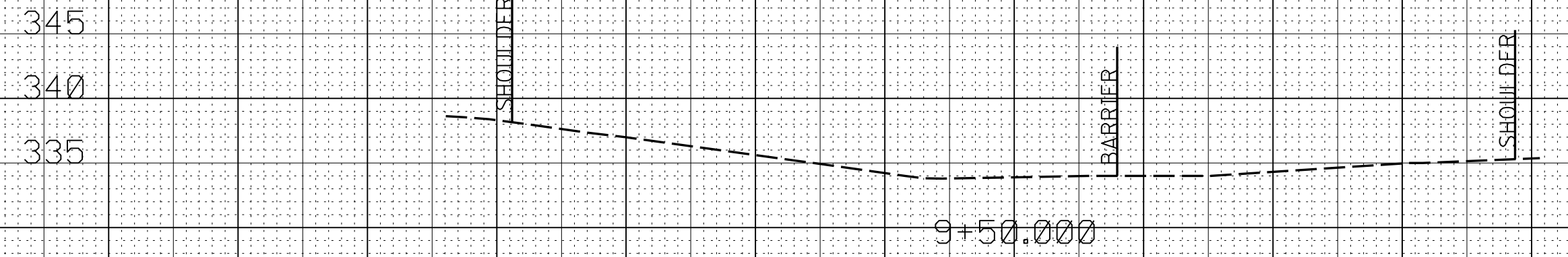
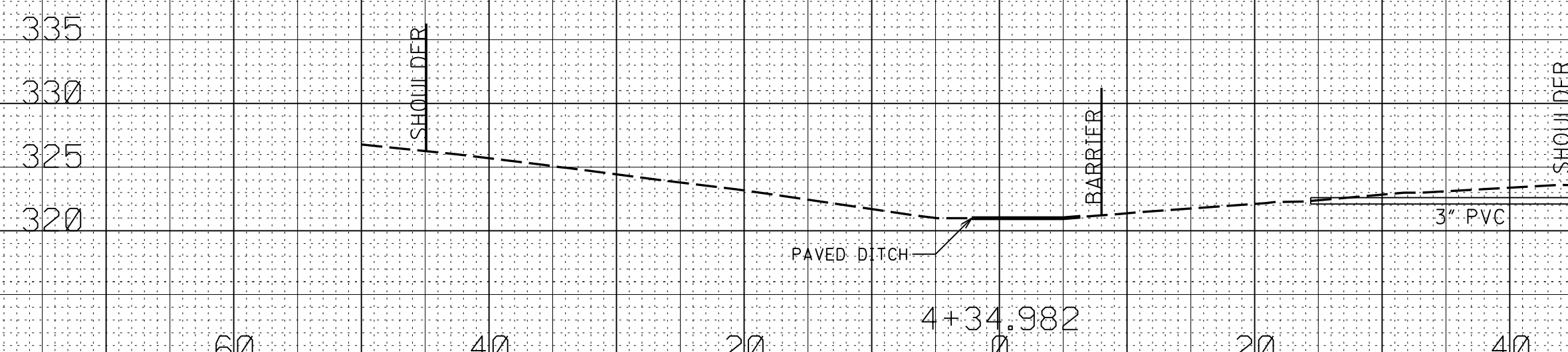
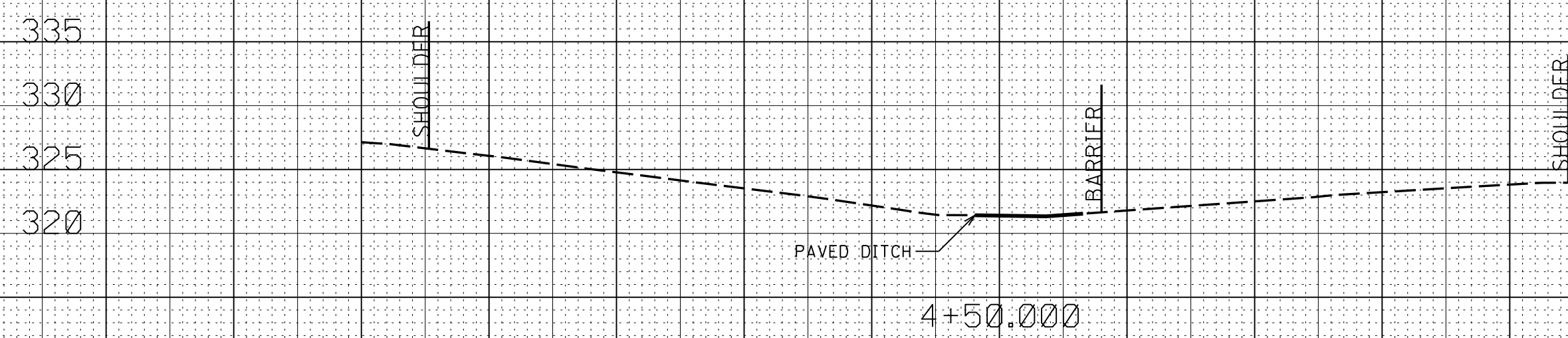
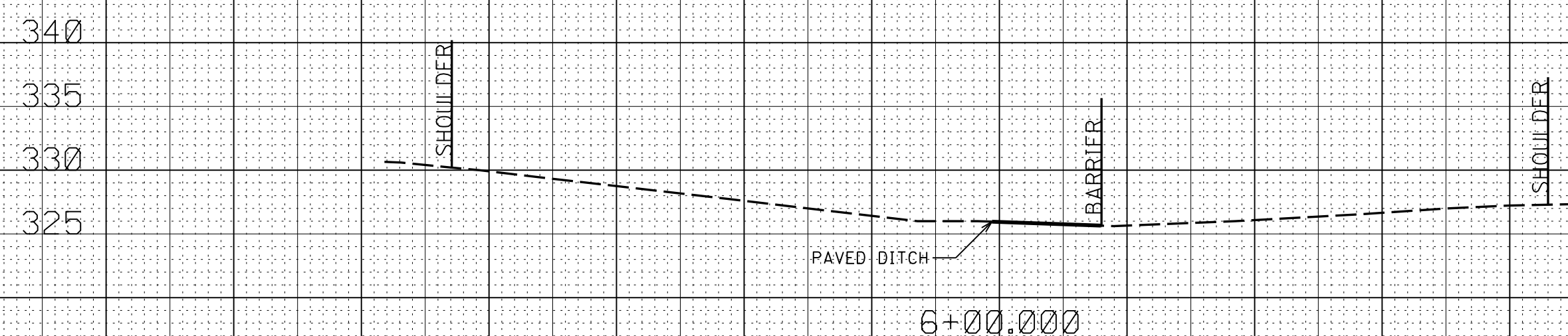
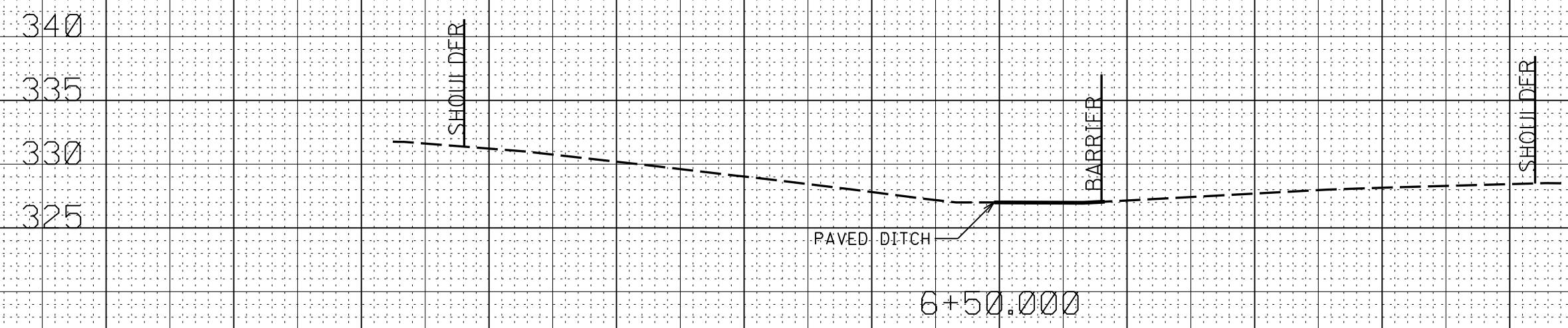
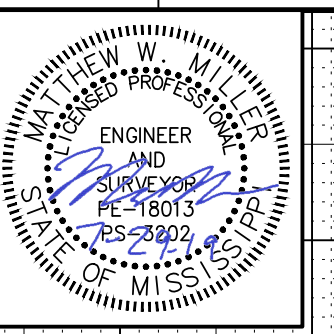

7/30/2019 8:35 AM LAT-HOL.MES3.DGN

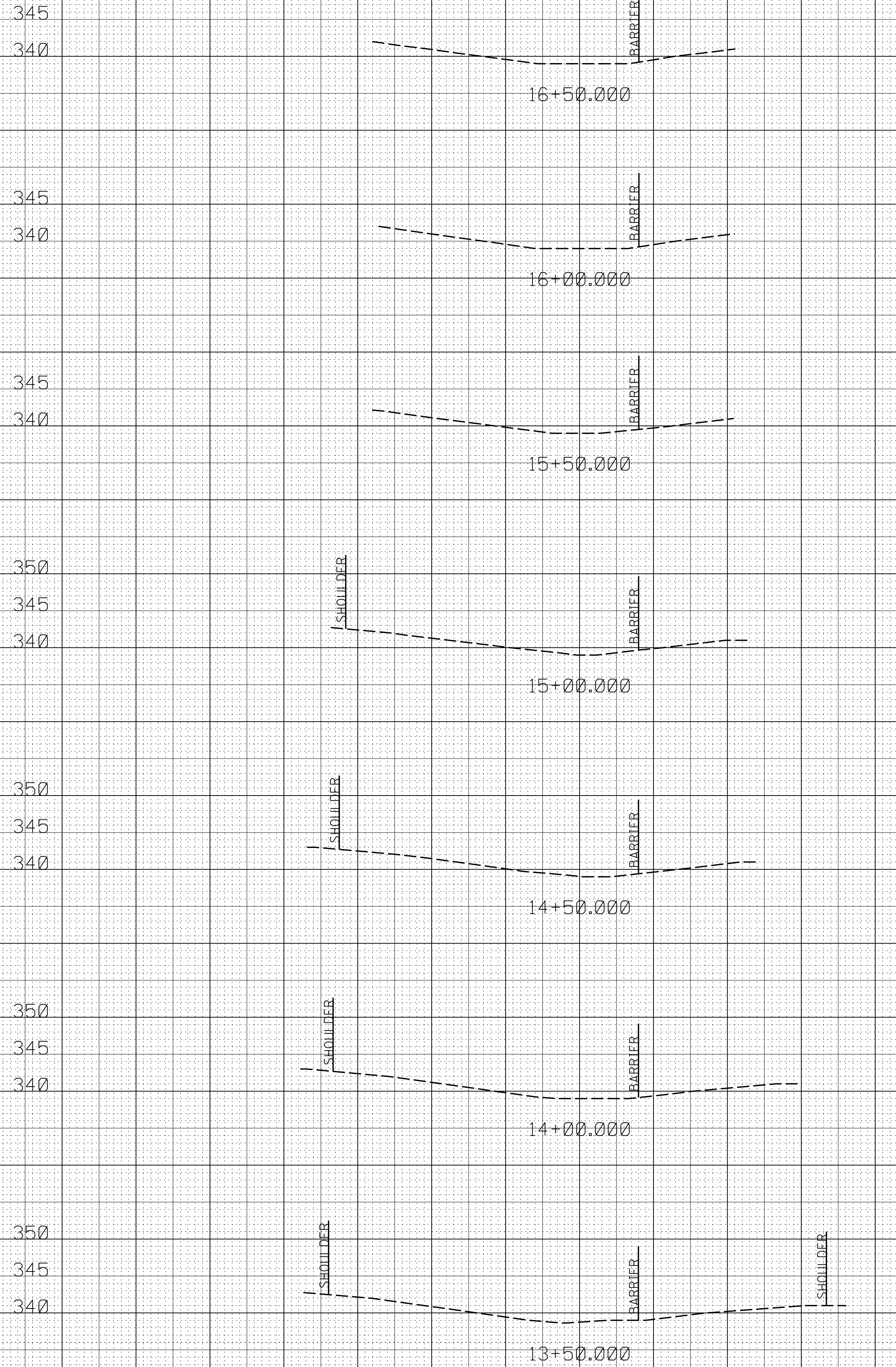
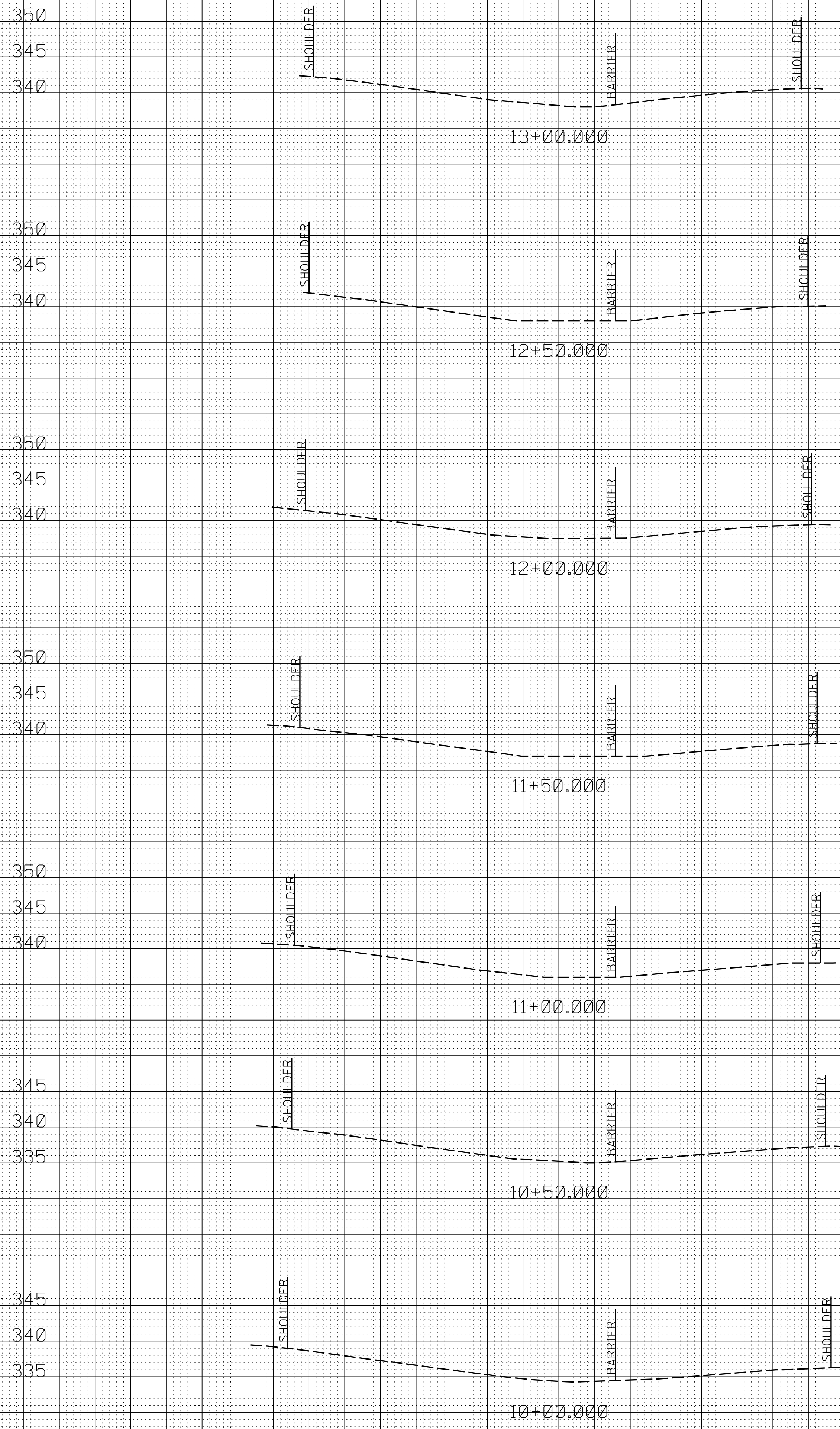
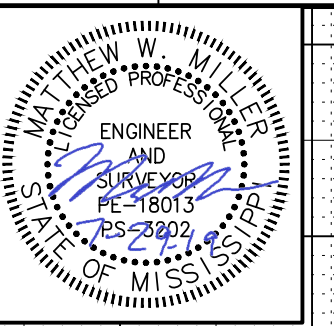

7/30/2019 8:35 AM LAY-HOLMES3.DGN

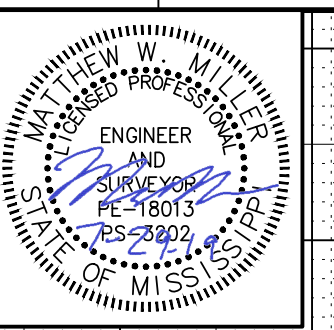

345
340

20+00.000

SHOULDER

BARRIER

350
345
340

19+50.000

SHOULDER

BARRIER

SHOULDER

350
345
340

19+00.000

SHOULDER

BARRIER

SHOULDER

350
345
340

18+50.000

SHOULDER

BARRIER

SHOULDER

350
345
340

18+00.000

SHOULDER

BARRIER

SHOULDER

350
345
340

17+50.000

SHOULDER

BARRIER

SHOULDER

345
340

17+00.000

345
340
335

23+50.000

SHOULDER

BARRIER

SHOULDER

345
340
335

23+00.000

SHOULDER

BARRIER

SHOULDER

345
340

22+50.000

SHOULDER

BARRIER

SHOULDER

345
340

22+00.000

SHOULDER

BARRIER

SHOULDER

345
340

21+50.000

SHOULDER

BARRIER

SHOULDER

345
340

21+00.000

SHOULDER

BARRIER

SHOULDER

350
345
340

20+50.000

SHOULDER

BARRIER

SHOULDER

7/30/2019 8:35 AM LAY-HOLMES3.DGN

80 60 40 20 0 20 40 60 80 80 60 40 20 0 20 40

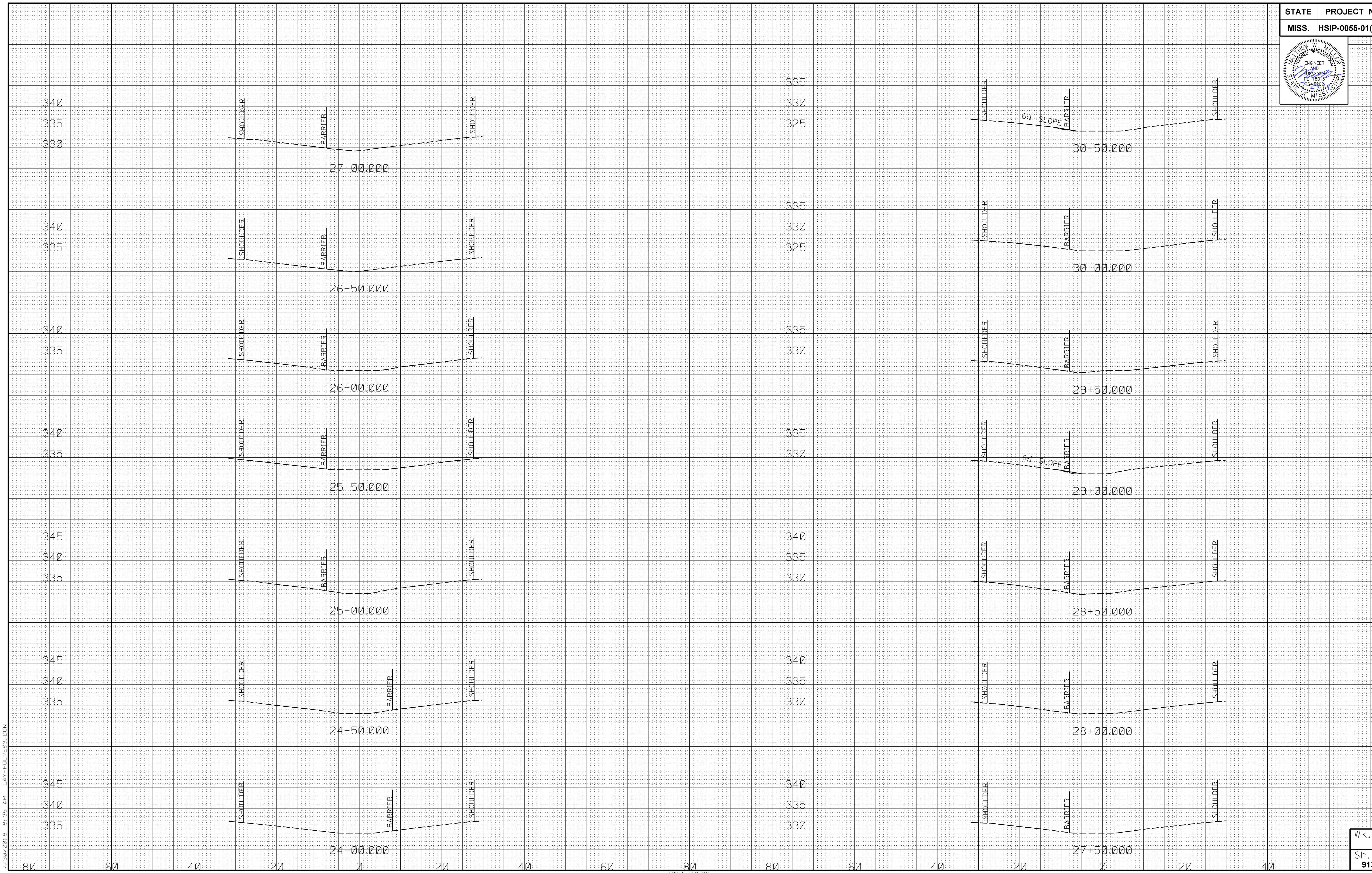
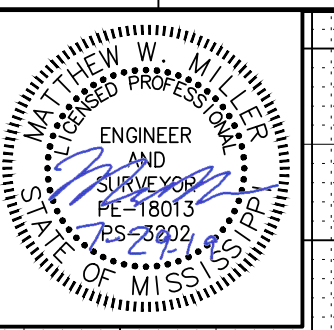

7/30/2019 8:35 AM LAY-HOLMES3.DGN

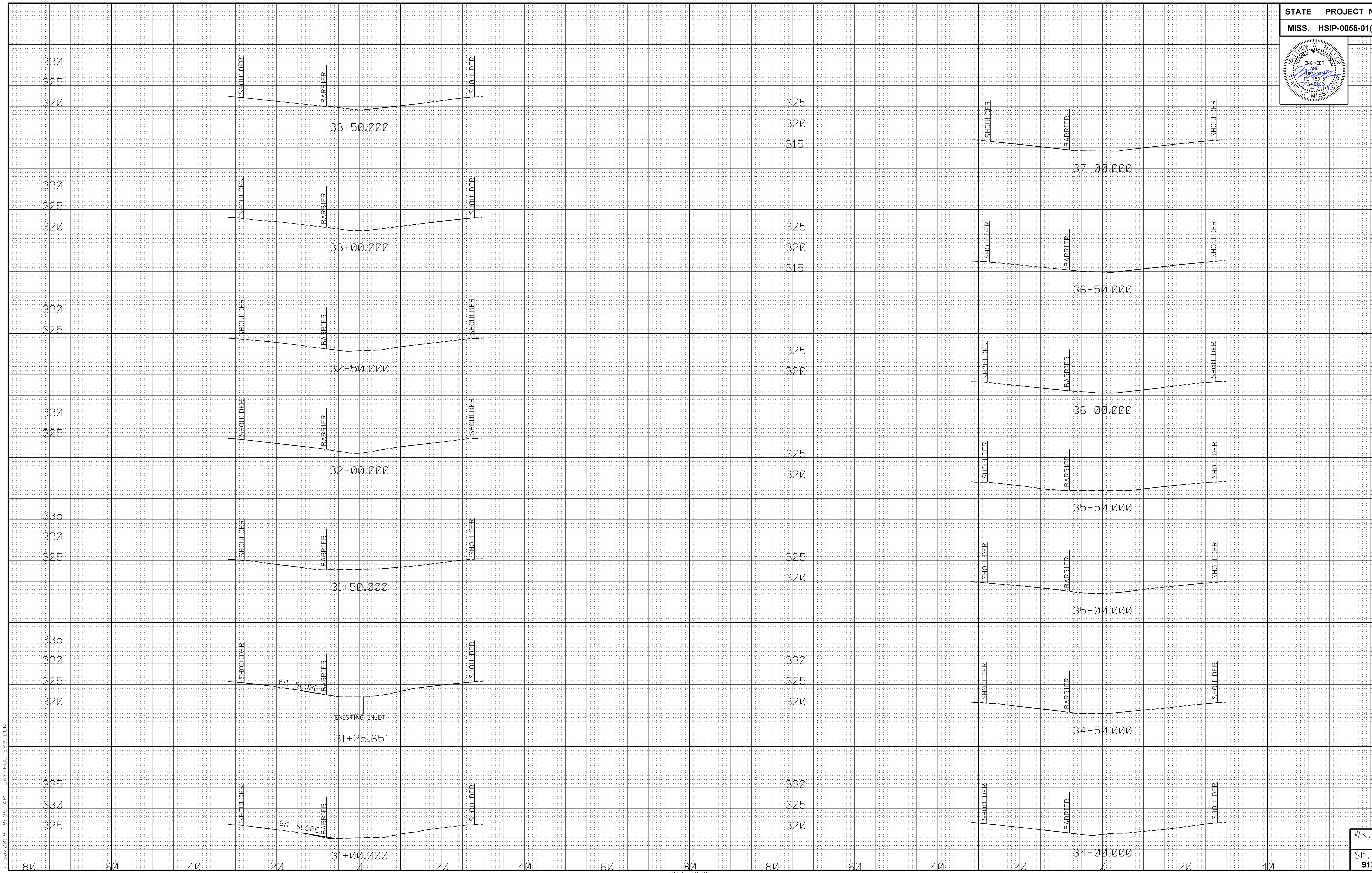
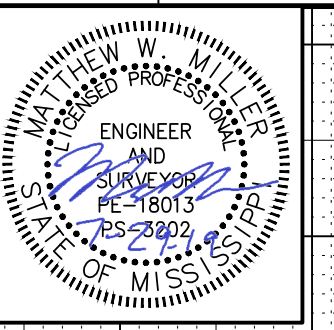

7/30/2019 8:35 AM LAY-HOLMES3.DGN

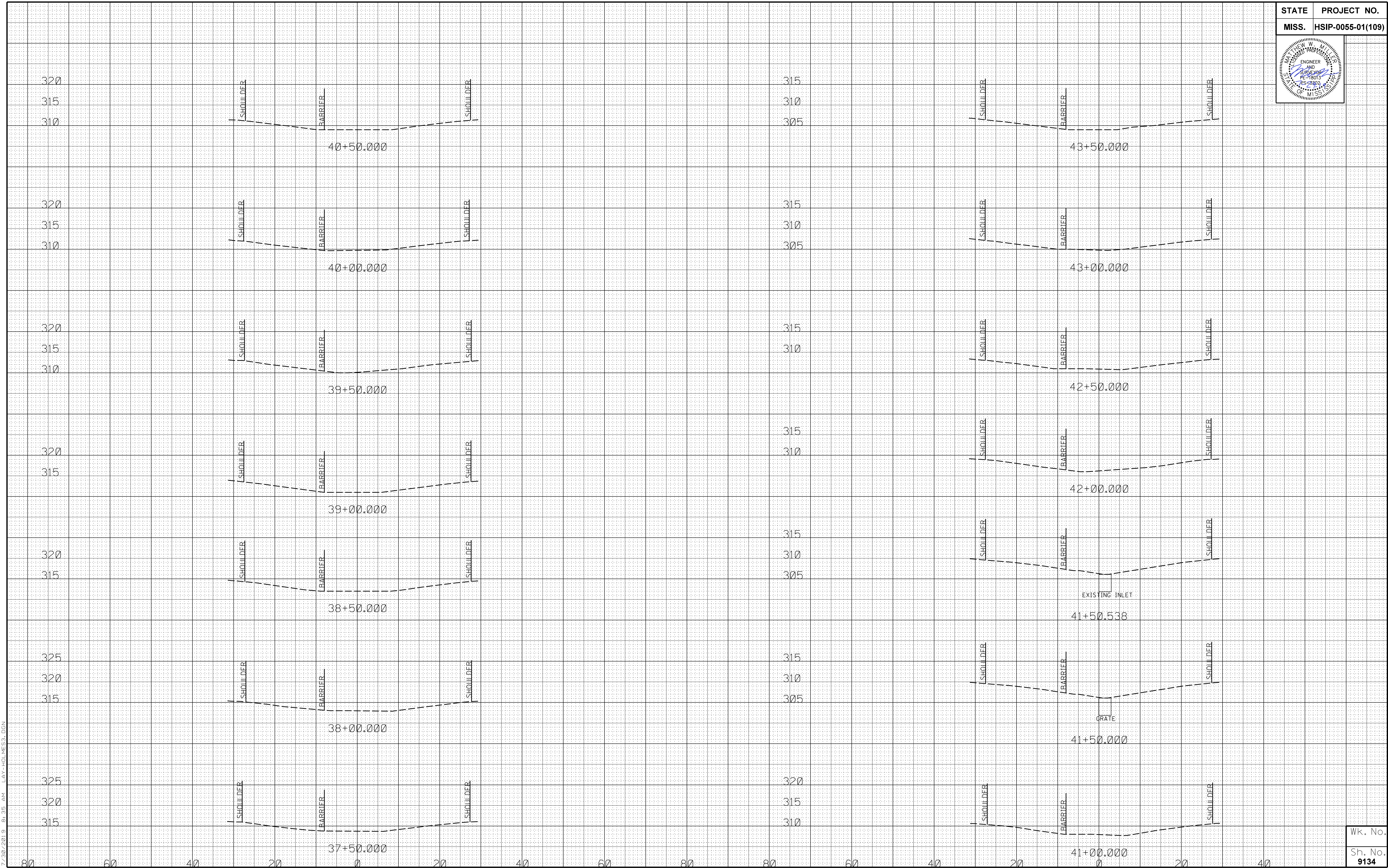
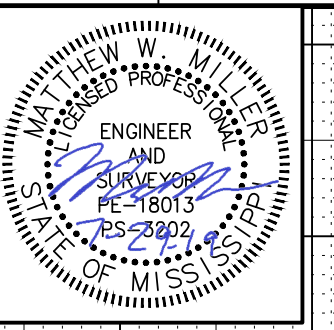

7/30/2019 8:35 AM LAY-HOLMES3.DGN

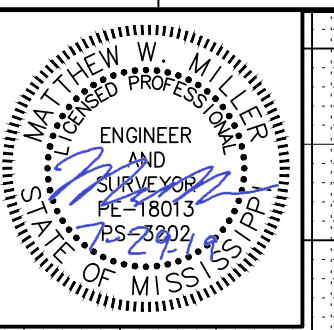

310
305
300

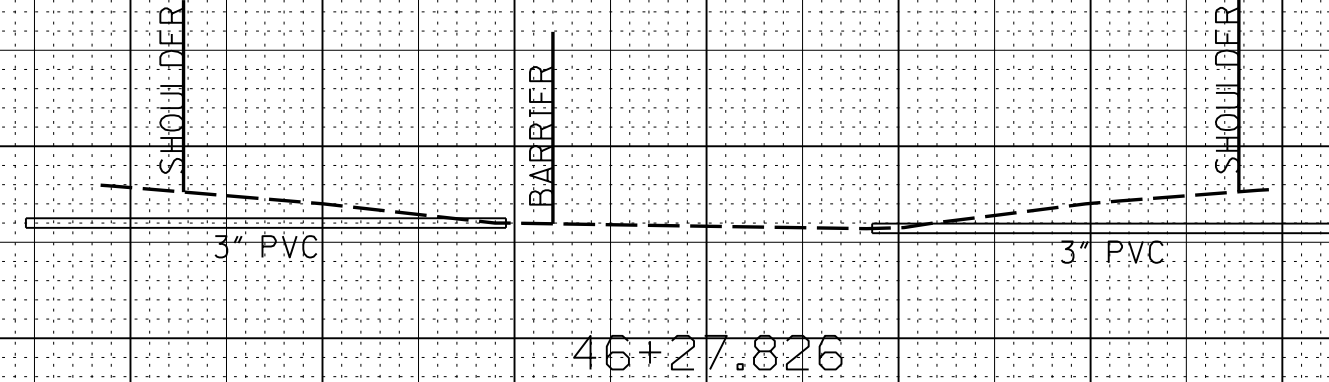

46+27.826

310
305

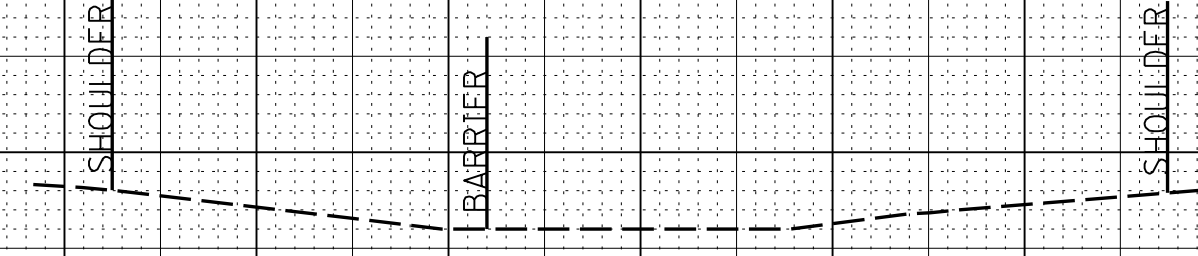

46+00.000

310
305



45+50.000

310
305

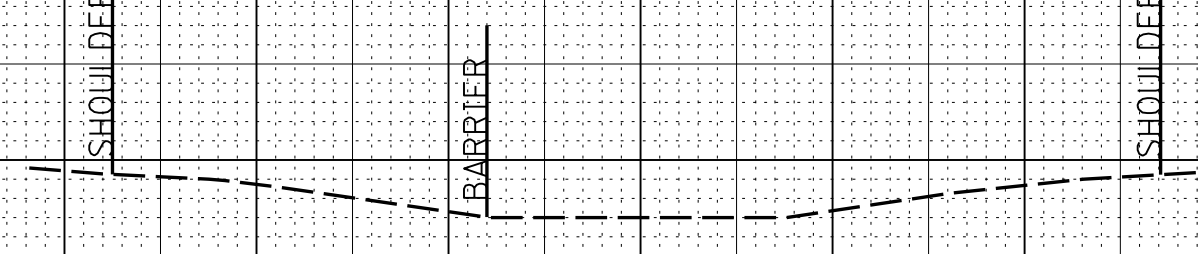

45+00.000

315
310
305

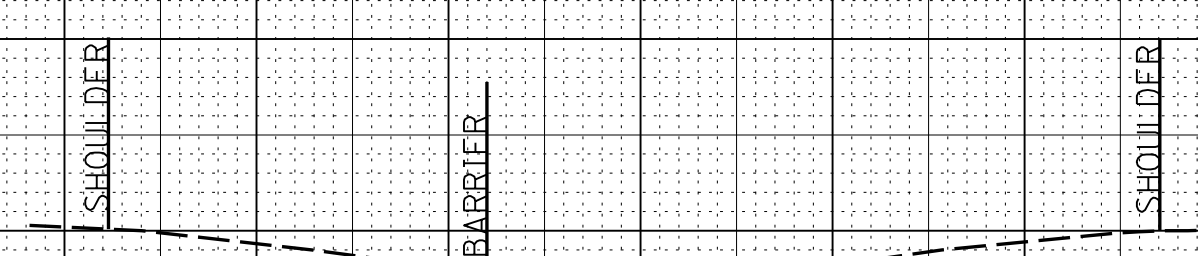

44+50.000

315
310
305

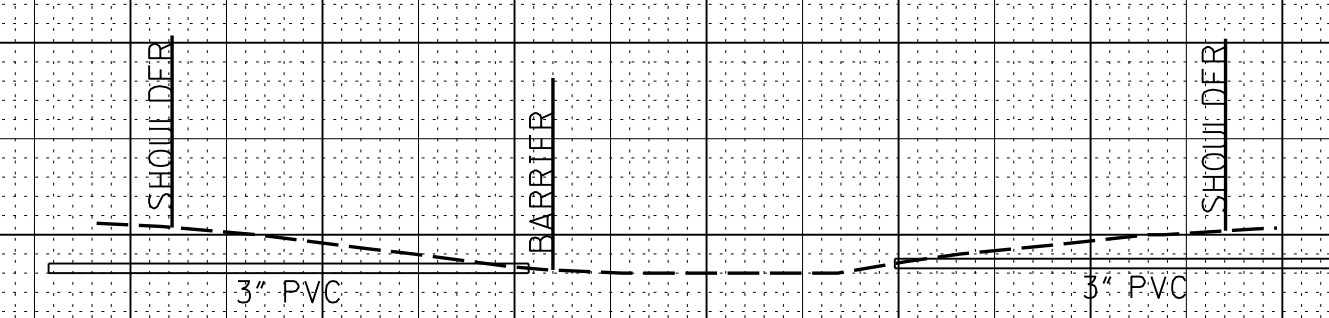

44+29.977

315
310
305

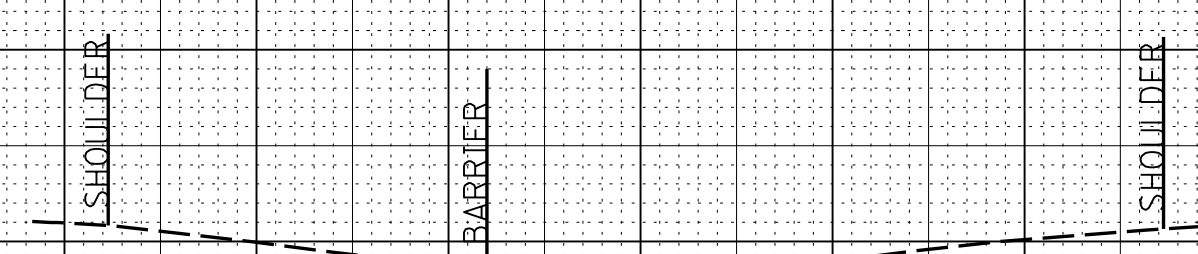

44+00.000

310
305
300
295

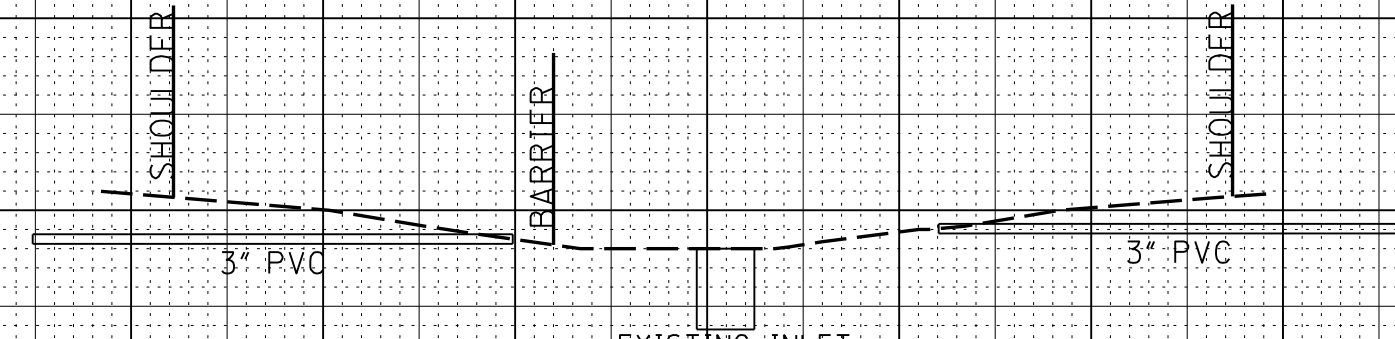

48+27.493

310
305
300
295

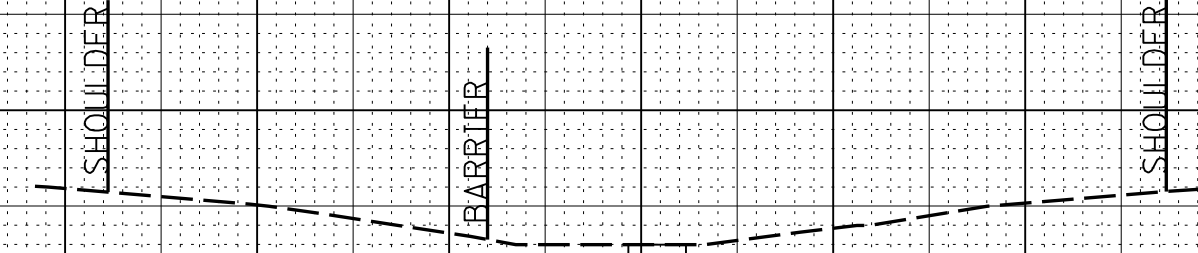

48+22.364

310
305
300

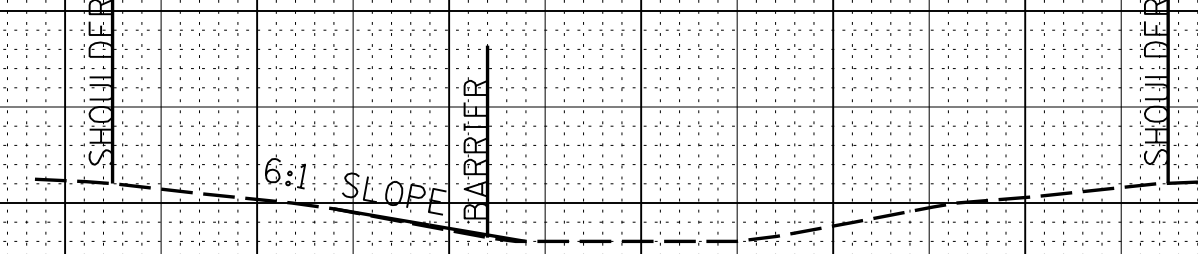

48+00.000

310
305
300

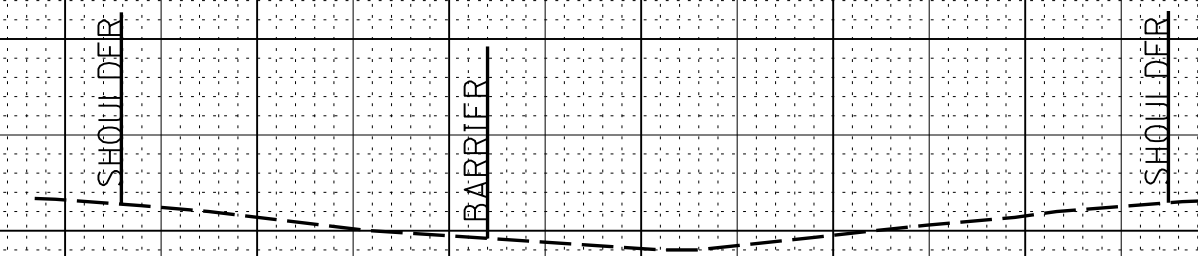

47+50.000

310
305
300

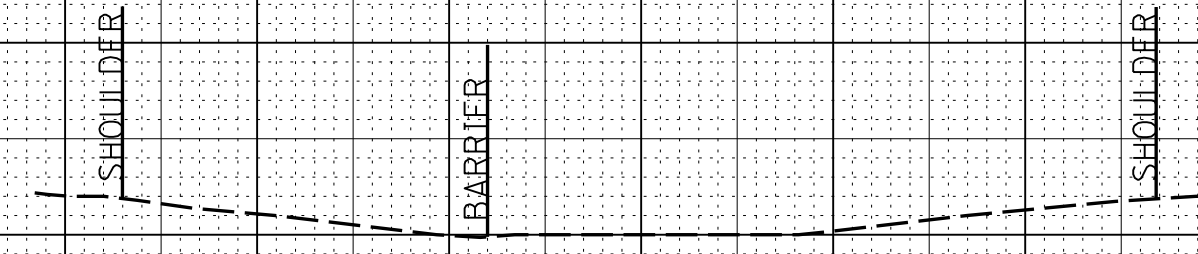

47+00.000

310
305
300



46+50.000

7/30/2019 8:35 AM LAY-HOLMES3.DGN

80 60 40 20 0 20 40 60 80 80 60 40 20 0 20 40

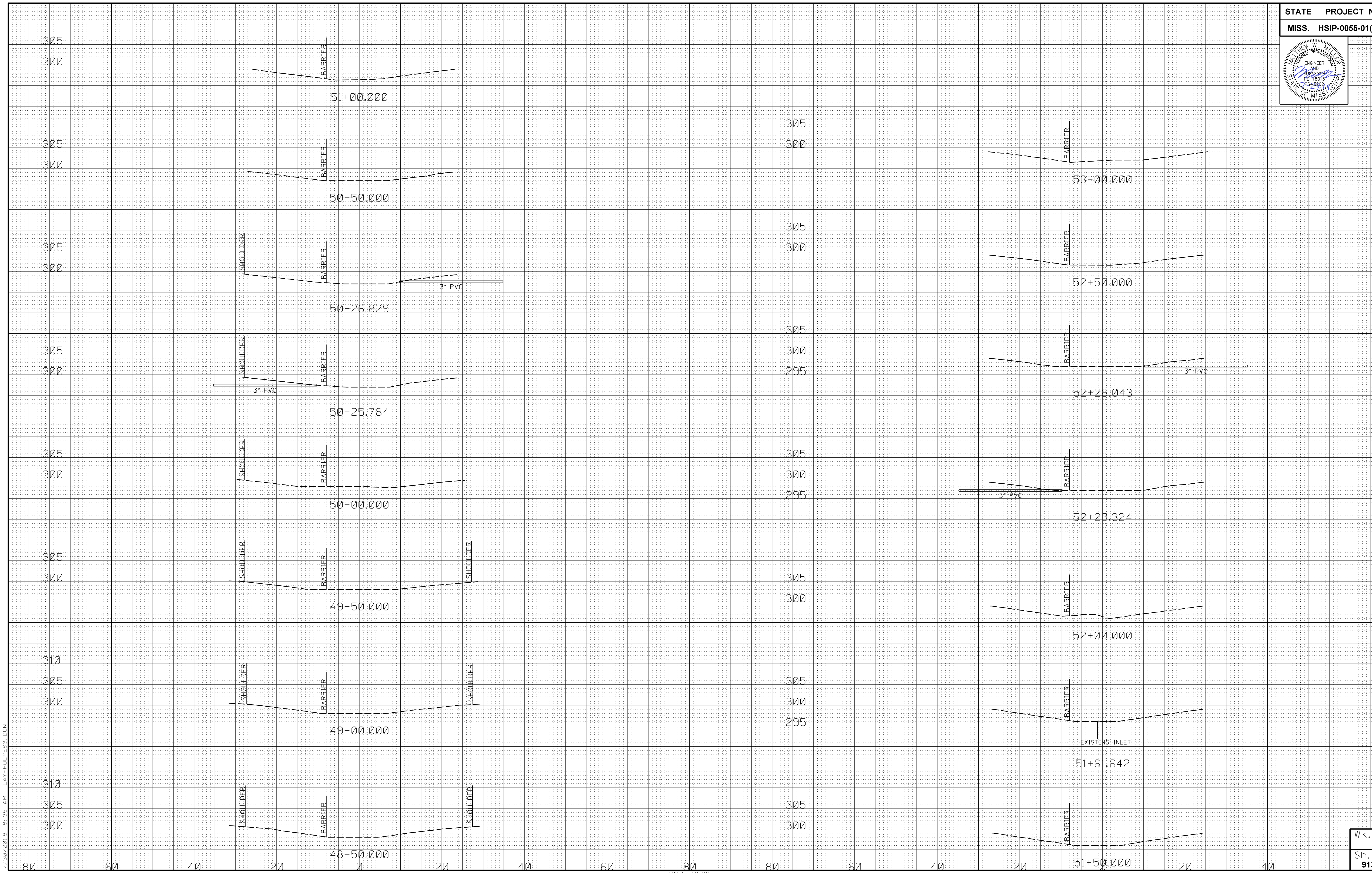
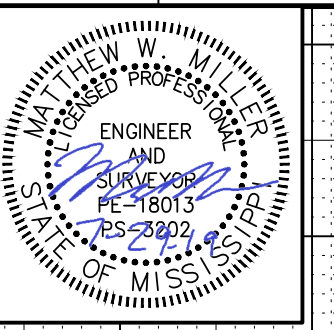

7/30/2019 8:35 AM LAY-HOLMES3.DGN

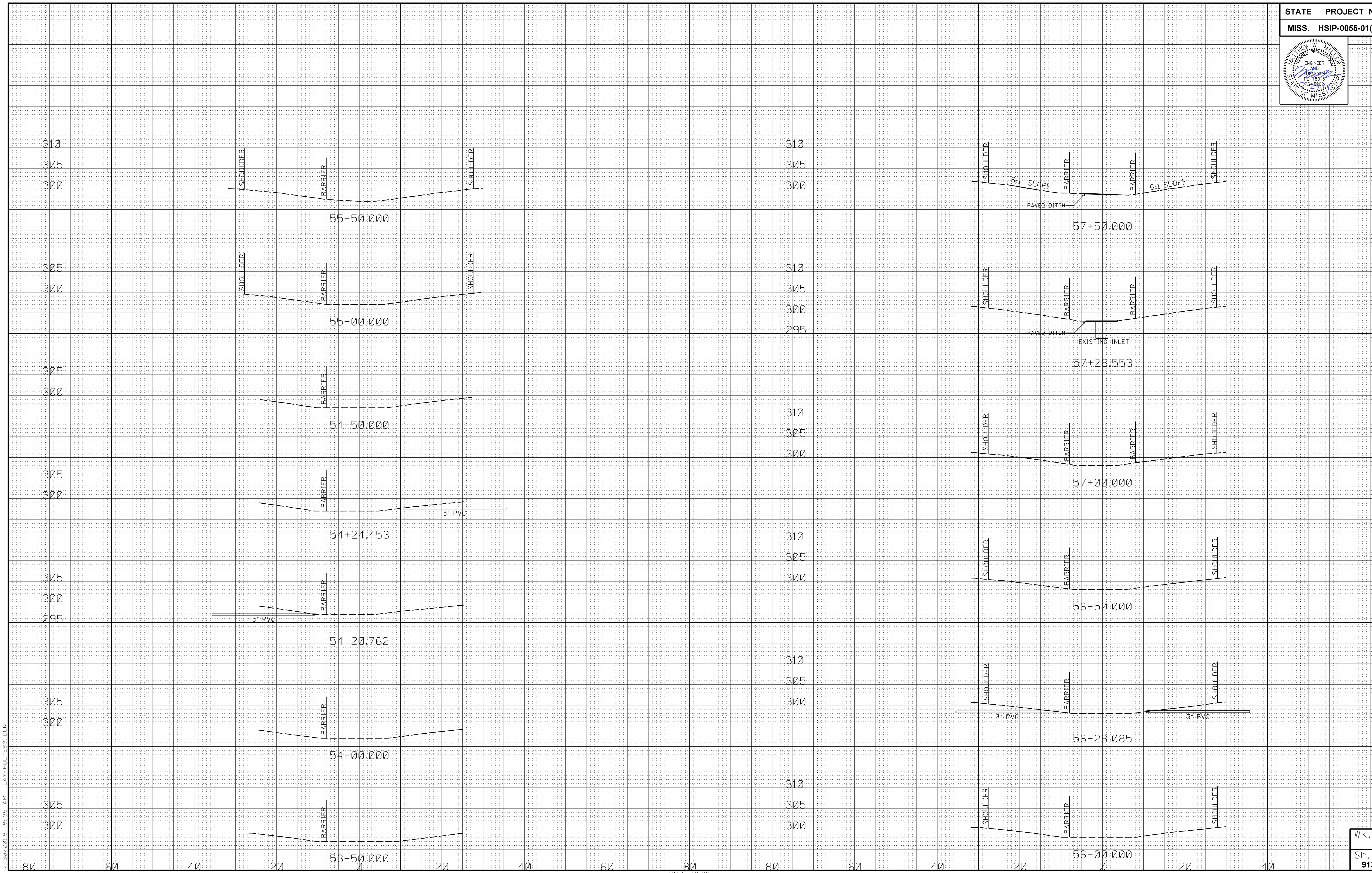
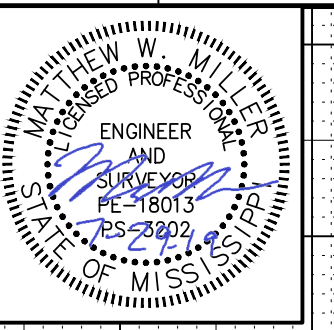

7/30/2019 8:35 AM LAY-HOLMES3.DGN

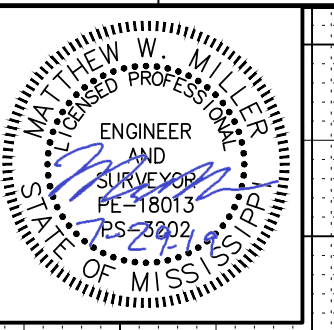

310
305
300
310
305
300
310
305
300
310
305
300
310
305
300
310
305
300
310
305
300
310
305
300
310
305
300
310
305
300
310
305
300
310
305
300
310
305
300
310
305
300

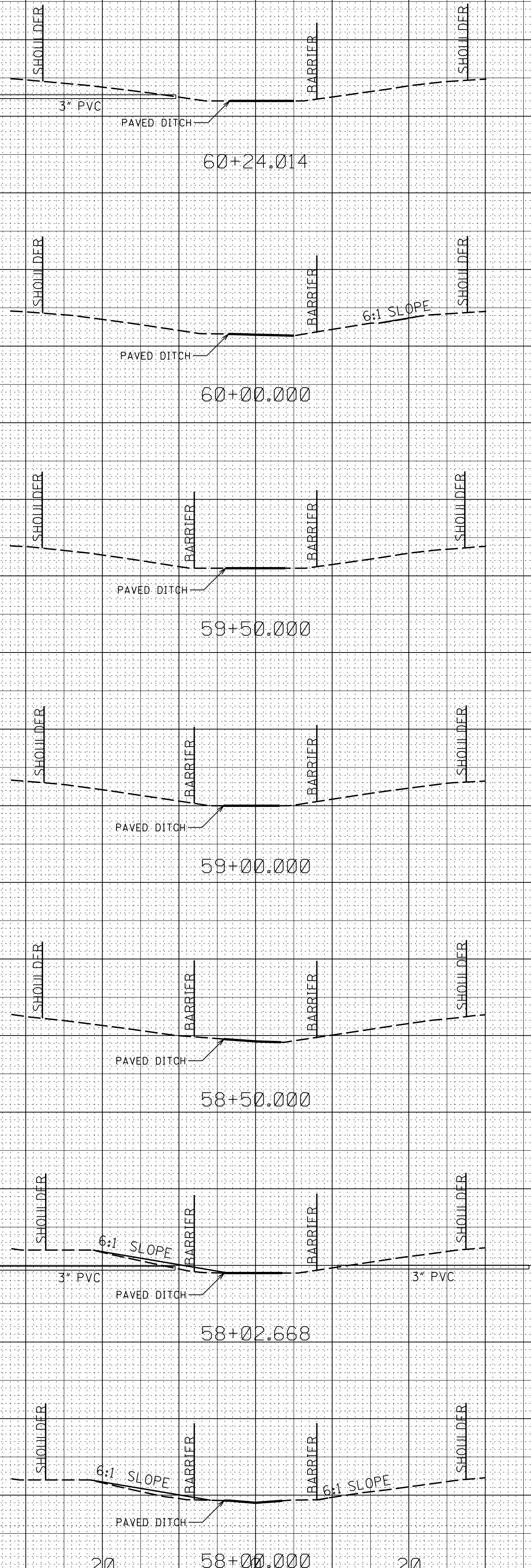

315
310
305
315
310
305
315
310
305
315
310
305
315
310
305
315
310
305
315
310
305
315
310
305
315
310
305
315
310
305
315
310
305
315
310
305
315
310
305
315
310
305
315
310
305
315
310
305

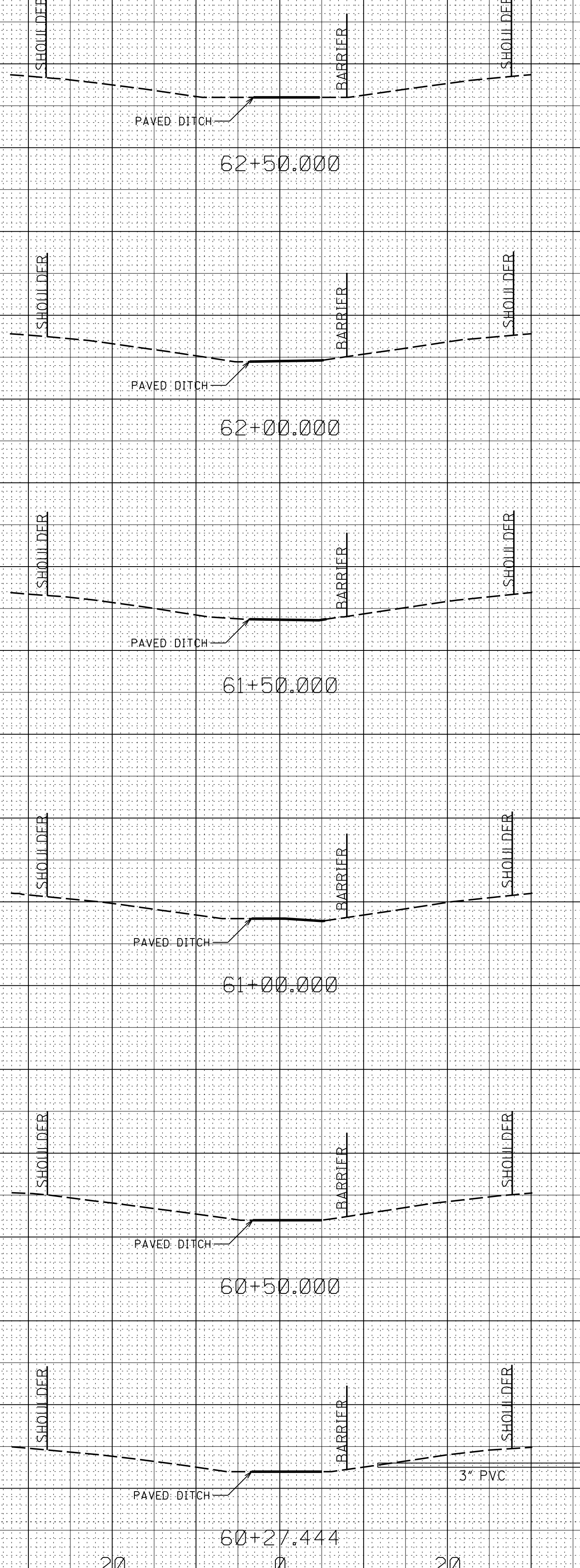

7/30/2019 8:35 AM LAY-HOLMES3.DGN

80 60 40 20 58+00.000 20 40 60 80 80 60 40 20 0 20 40

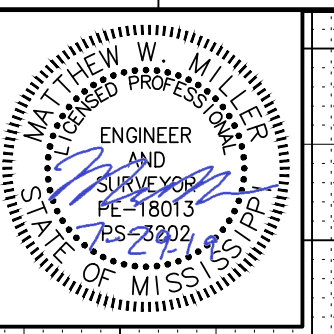

7/30/2019 8:35 AM LAY-HOLME3.DGN

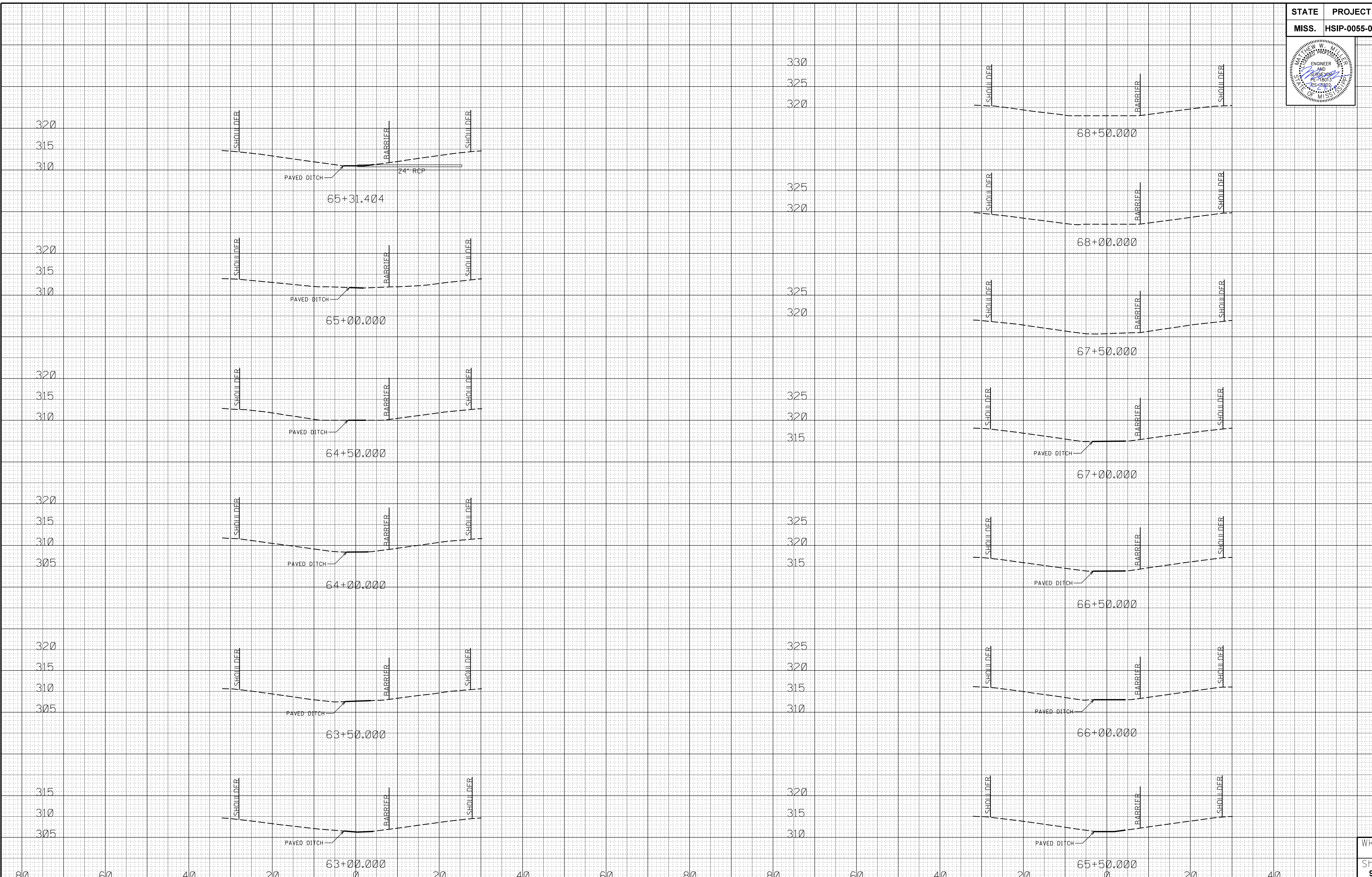

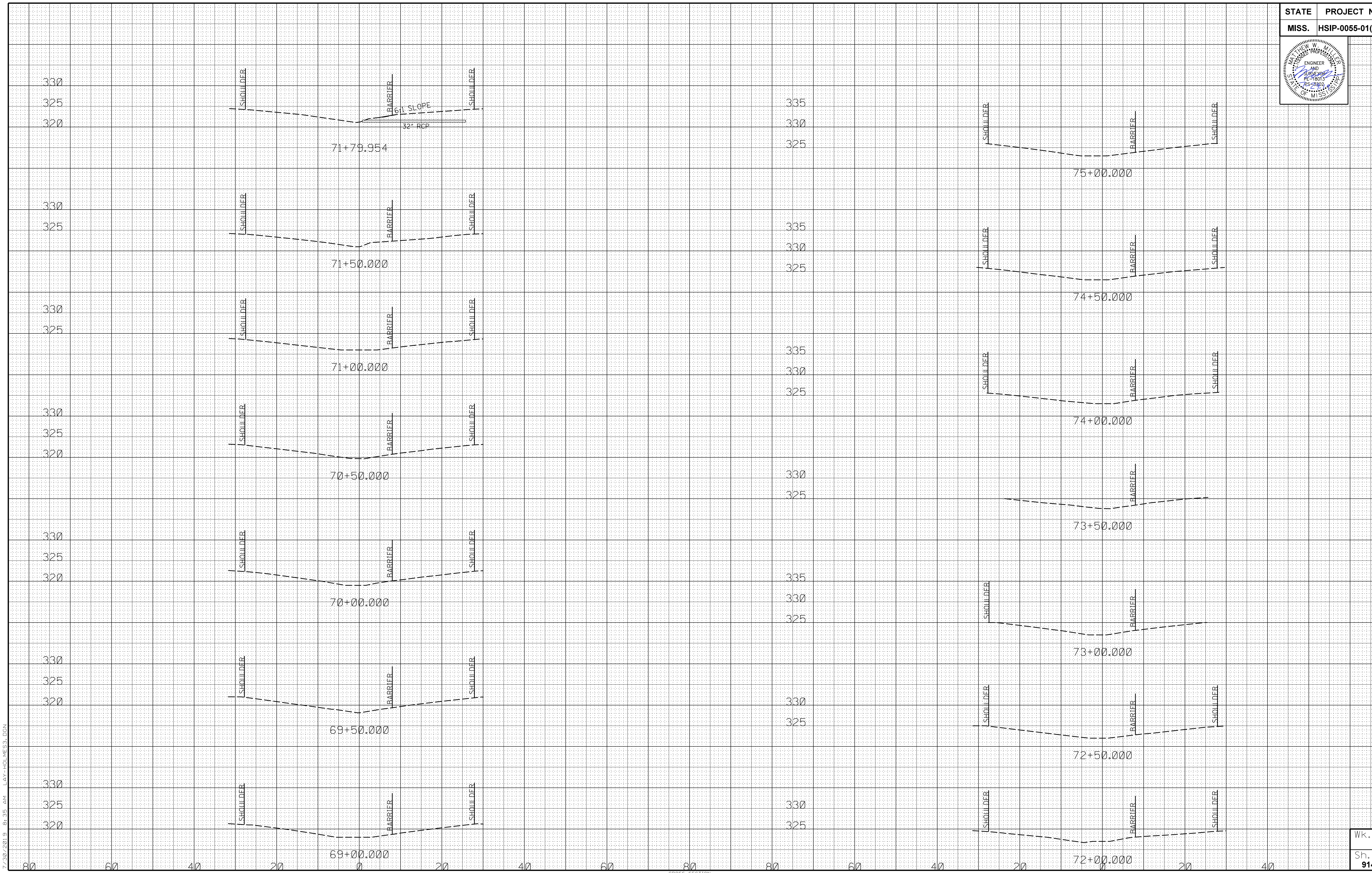
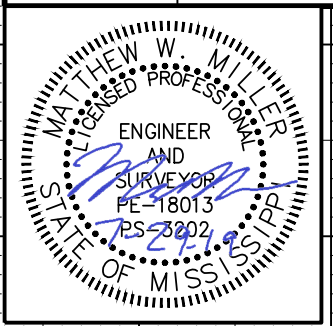

7/30/2019 8:35 AM LAY-HOLMES3.DGN

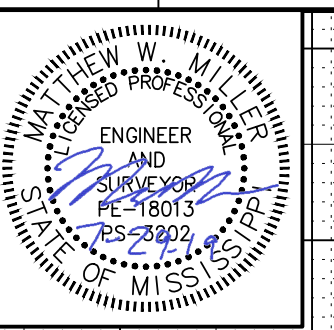

335

330

325

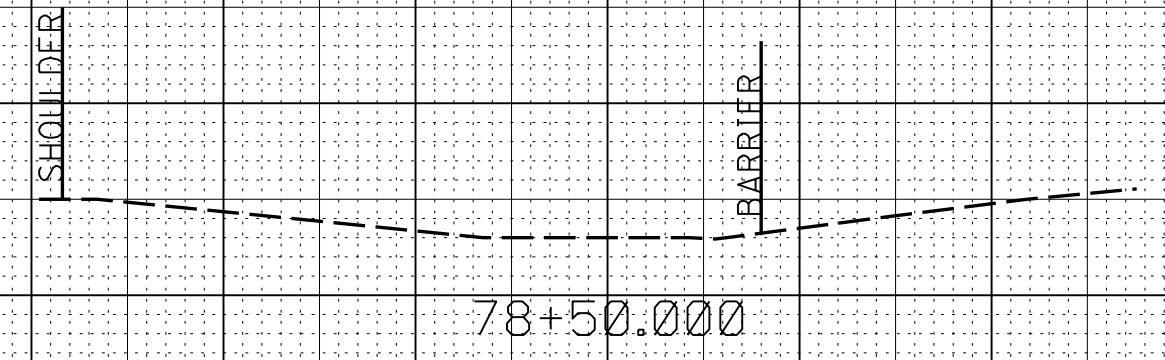

330

325

320

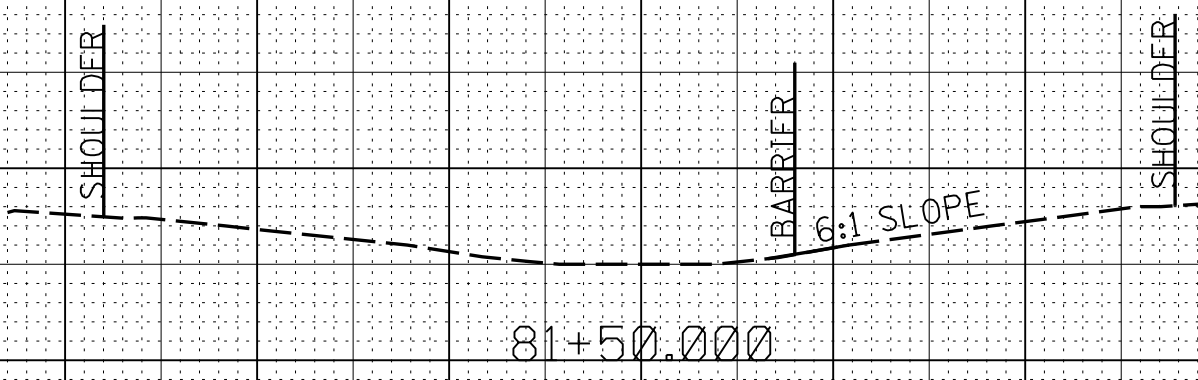

335

330

325

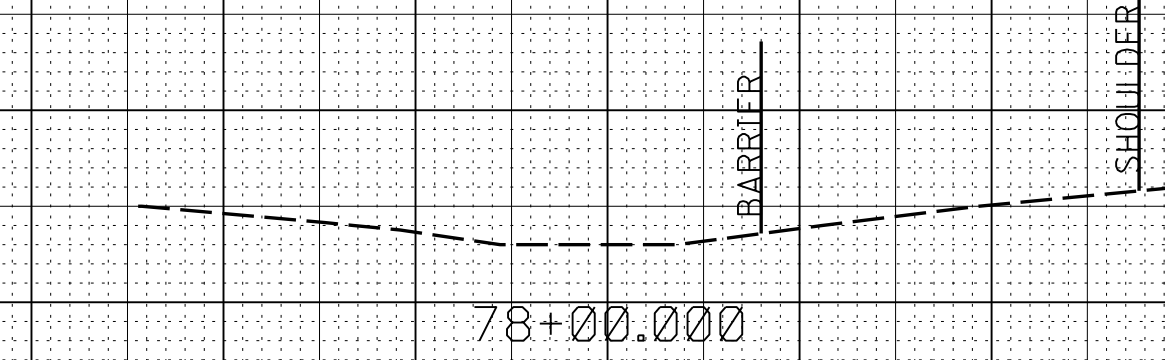

330

325

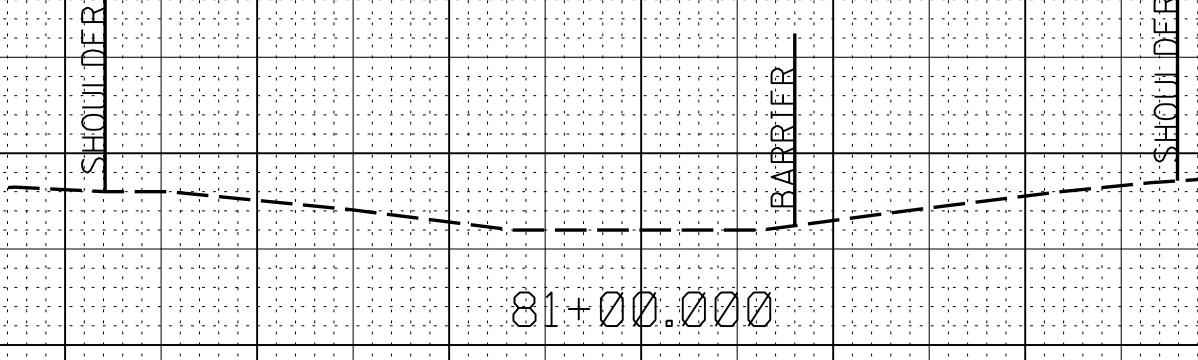

330

325

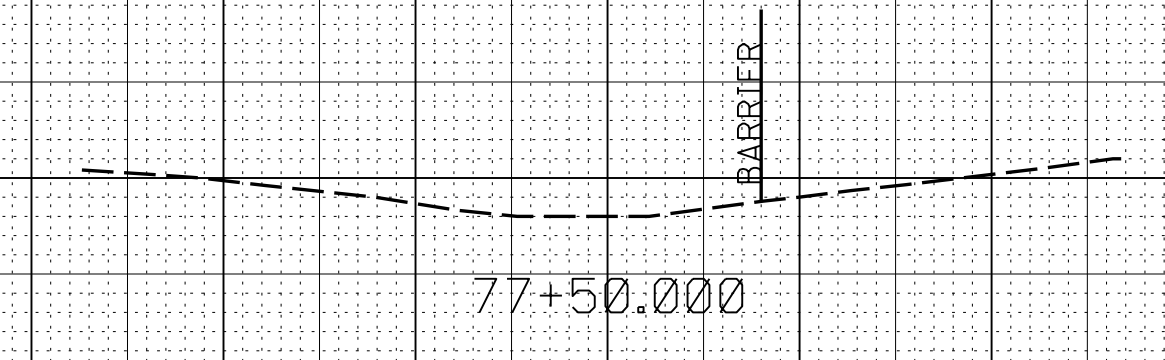

330

325

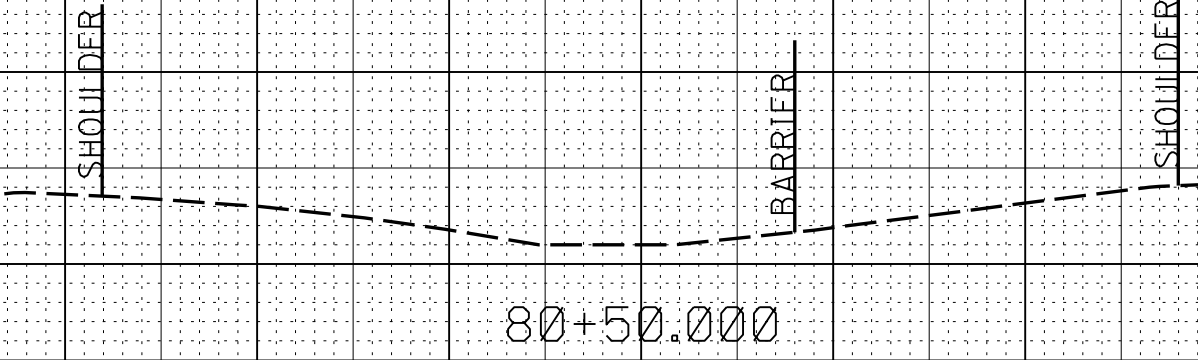

335

330

325

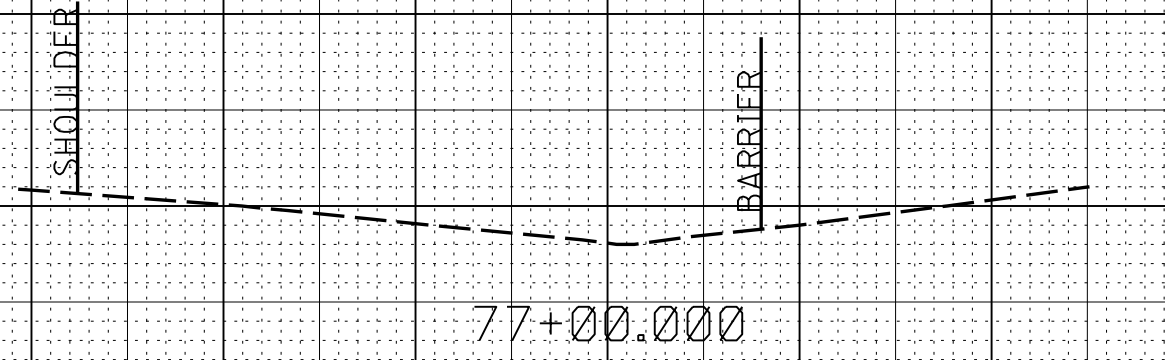

330

325

320

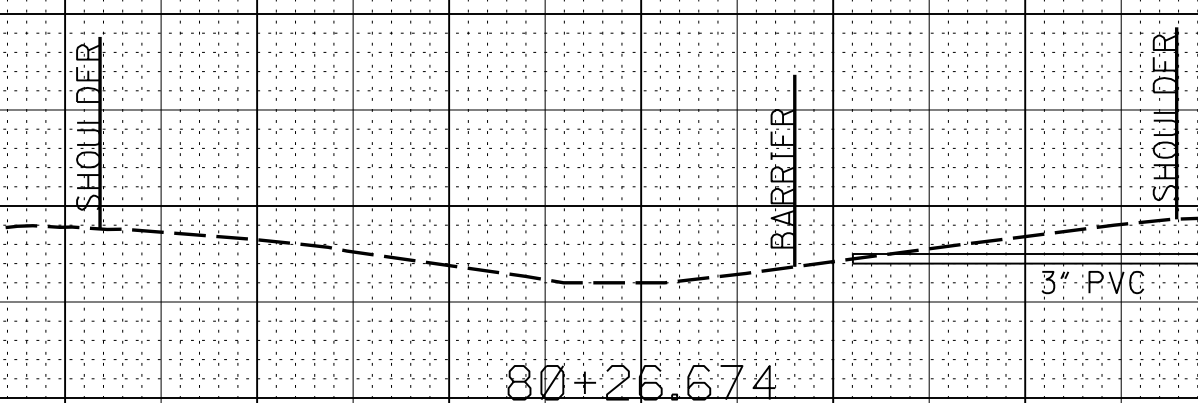

335

330

325

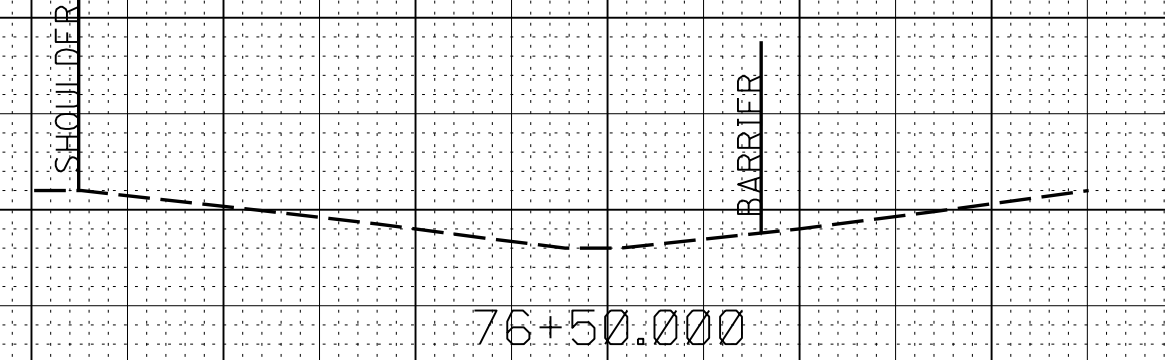

330

325

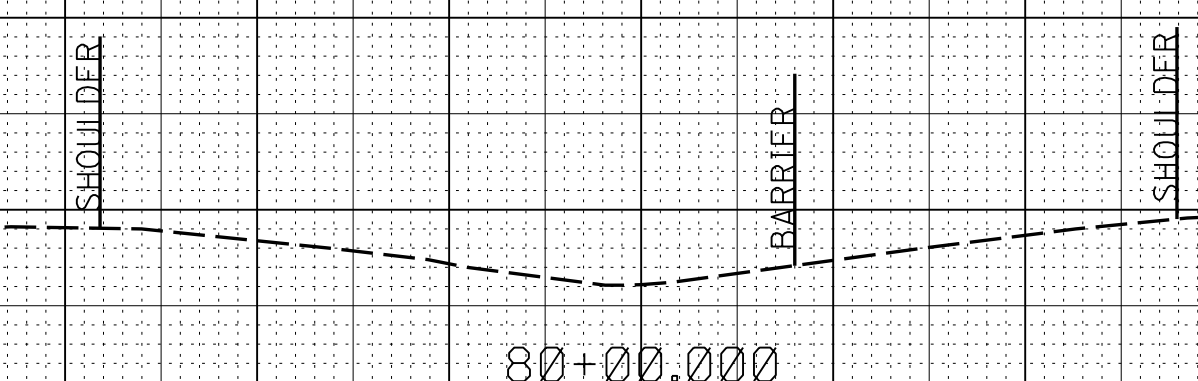

330

325

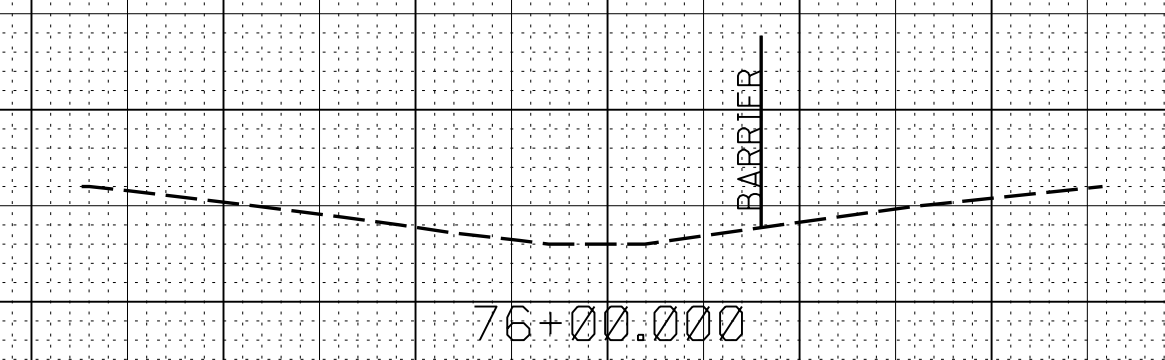

330

325

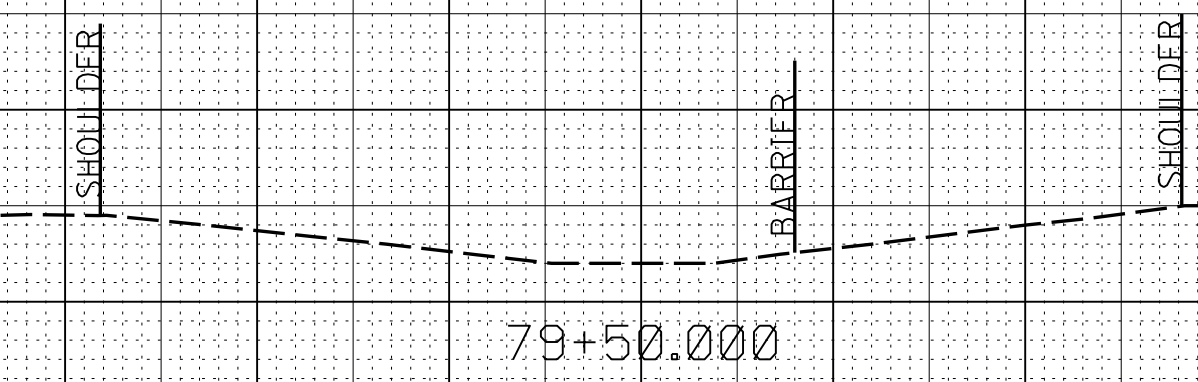

330

325

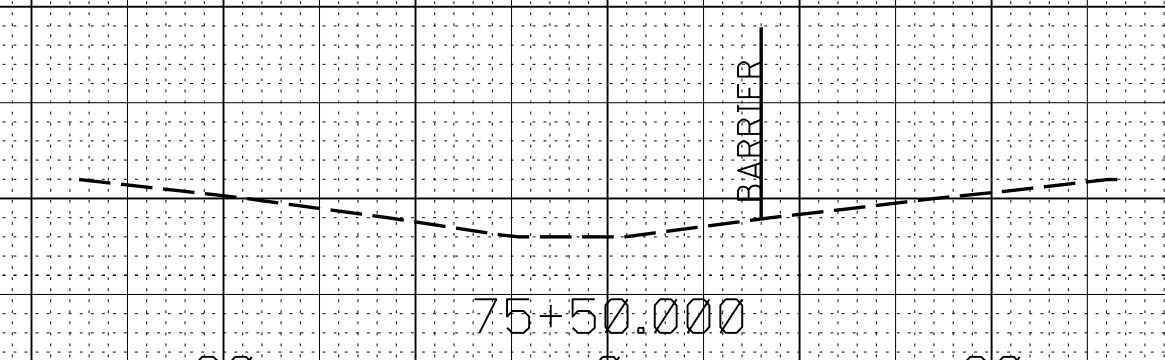

330

325

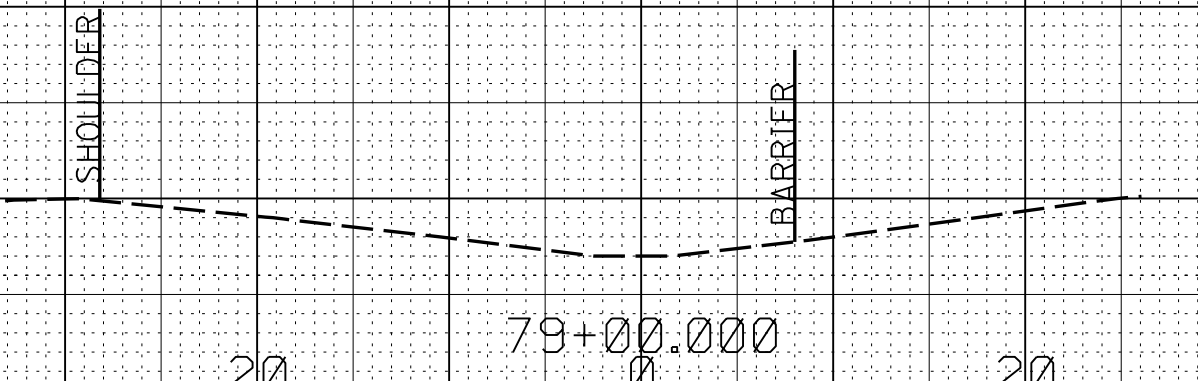

7/30/2019 8:35 AM LAY-HOLMES3.DGN

80 60 40 20 0 20 40 60 80 80 60 40 20 0 20 40

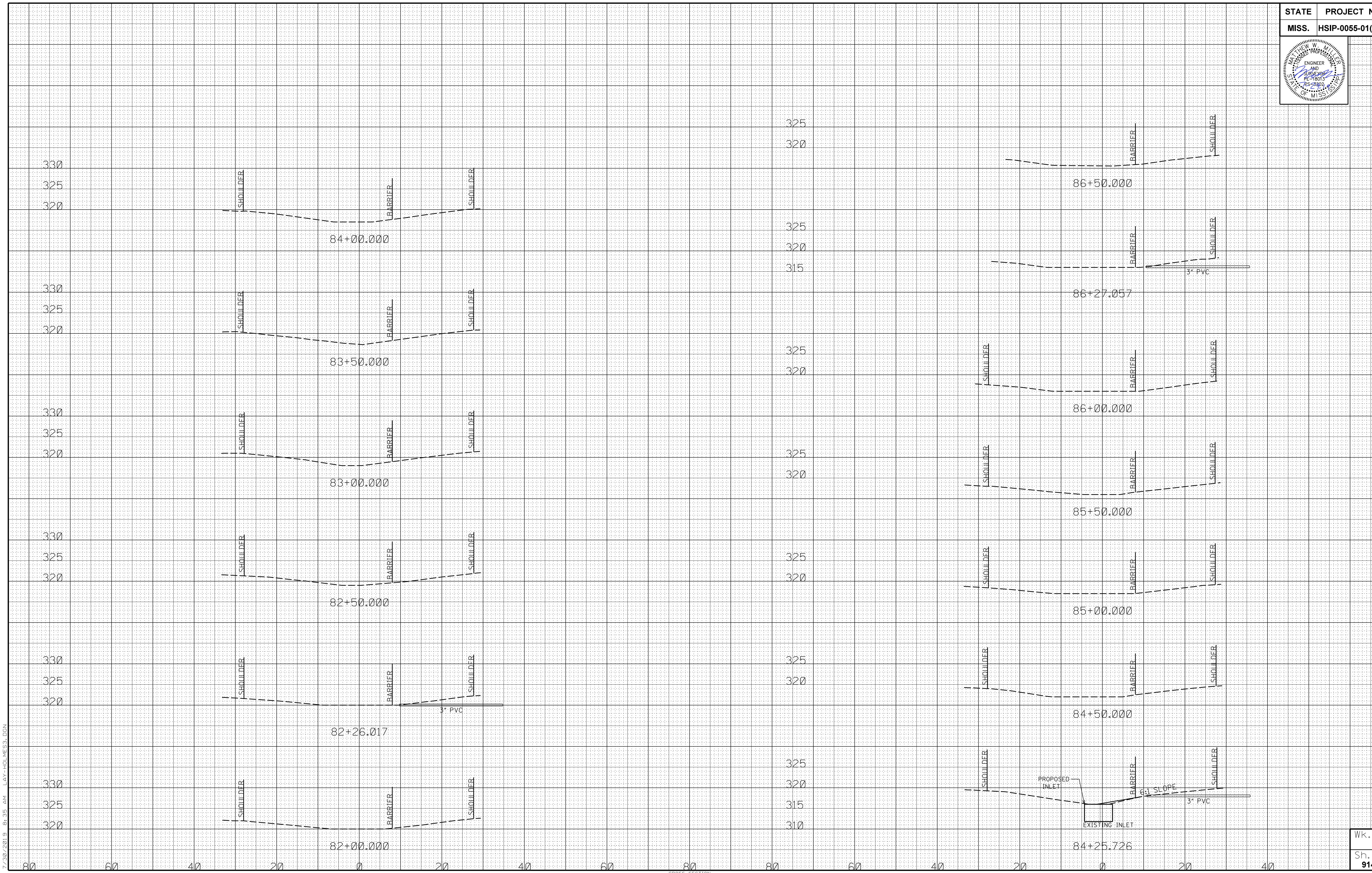
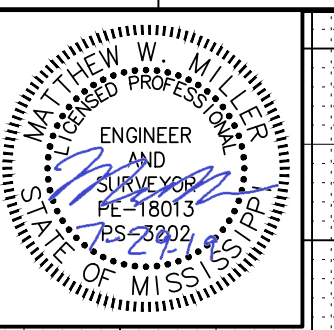

7/30/2019 8:35 AM LAT-HOLMES3.DGN

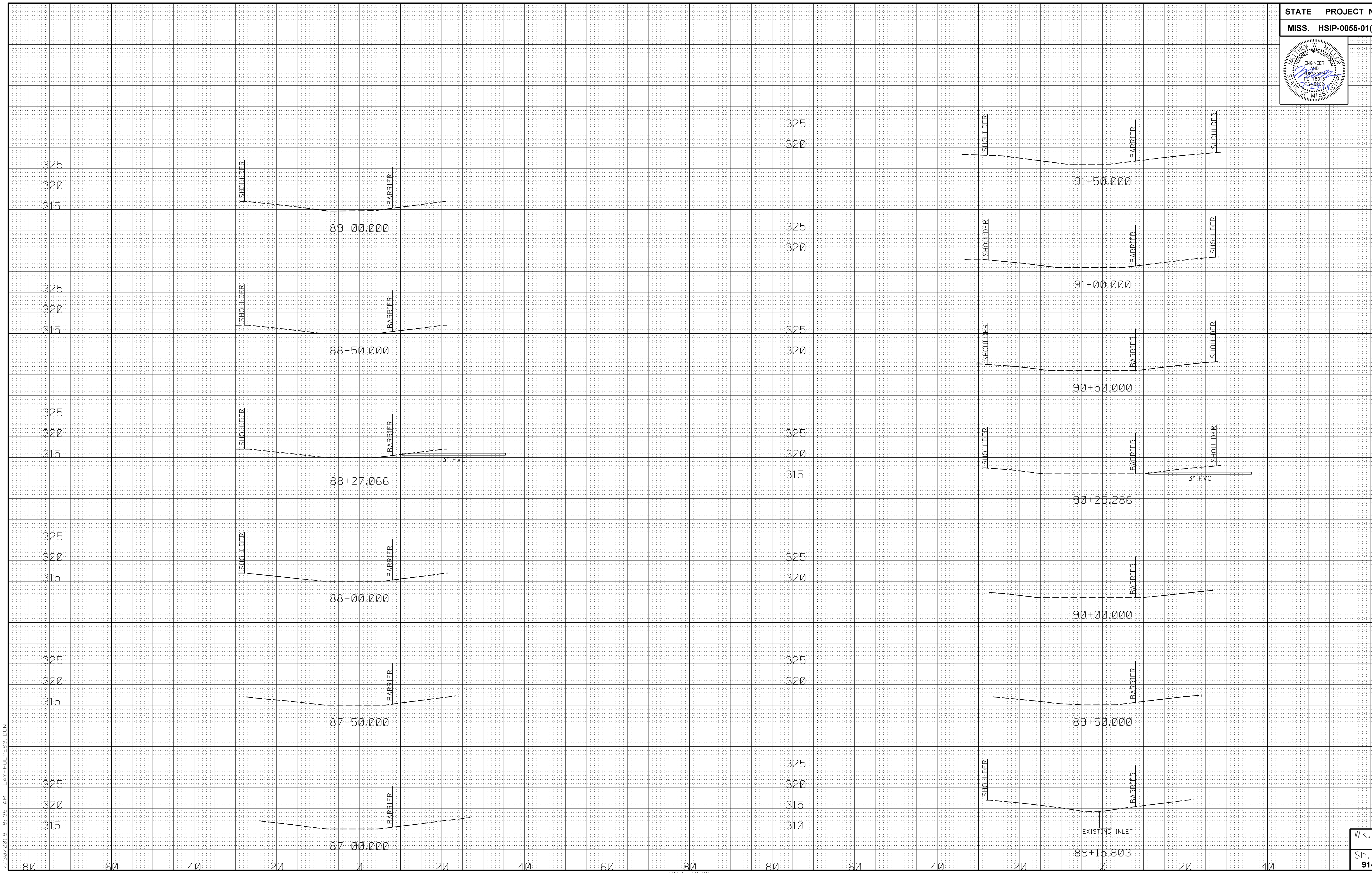
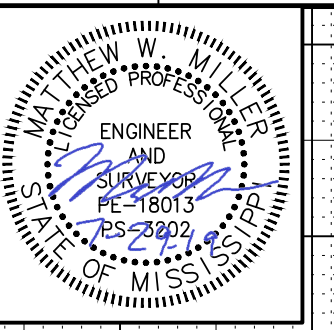

7/30/2019 8:35 AM LAT-HOLMES3.DGN

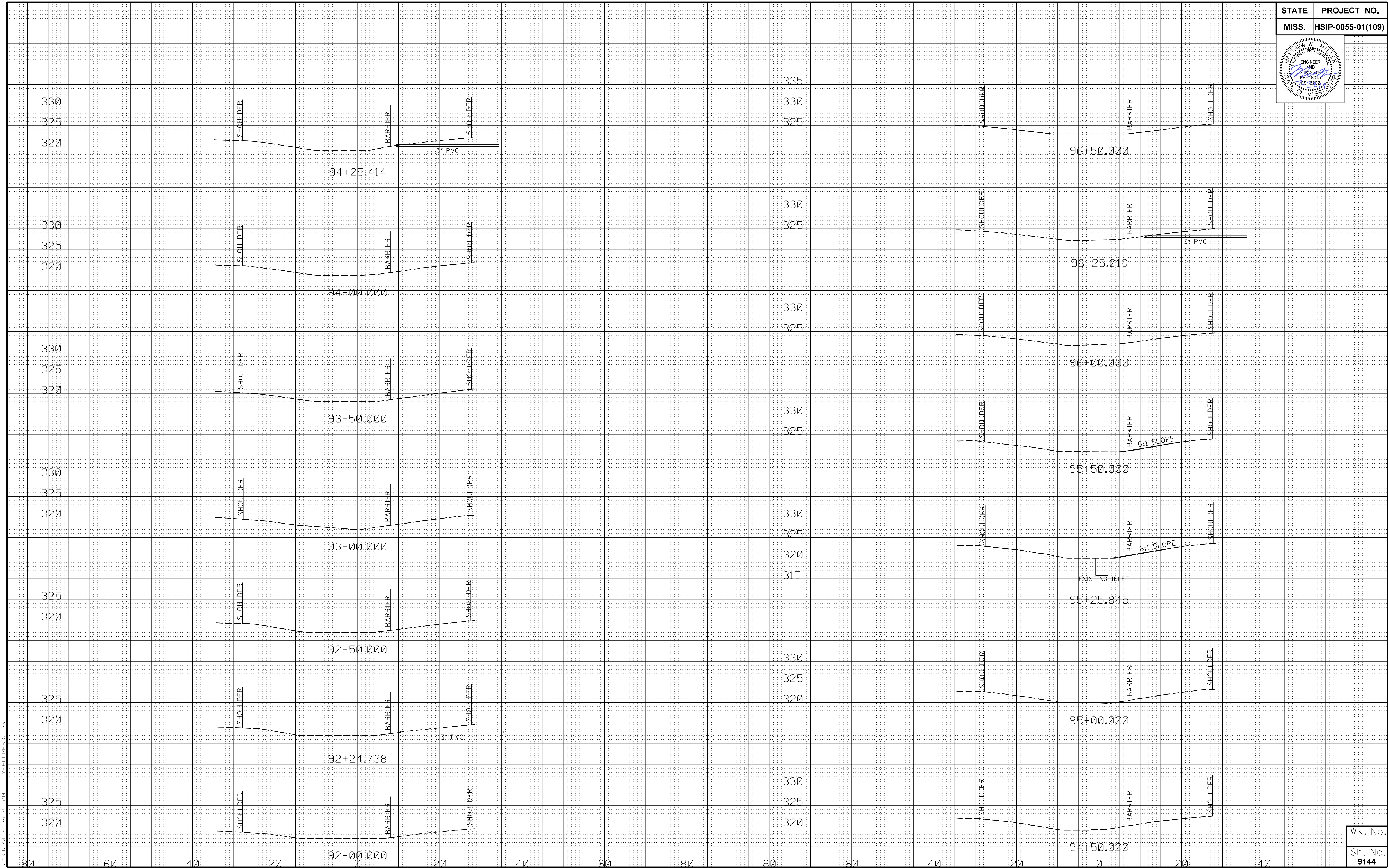
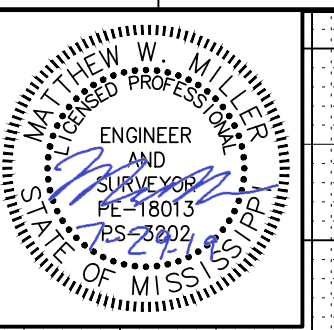

7/30/2019 8:35 AM LAY-HOLMES3.DGN

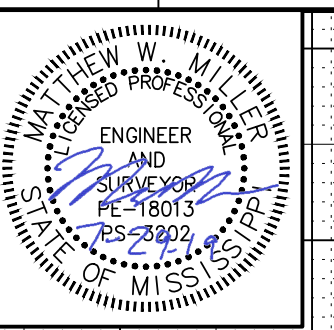

340
335
330
340
335
330
335
330
330
335
330
325
335
330
325
335
330
325

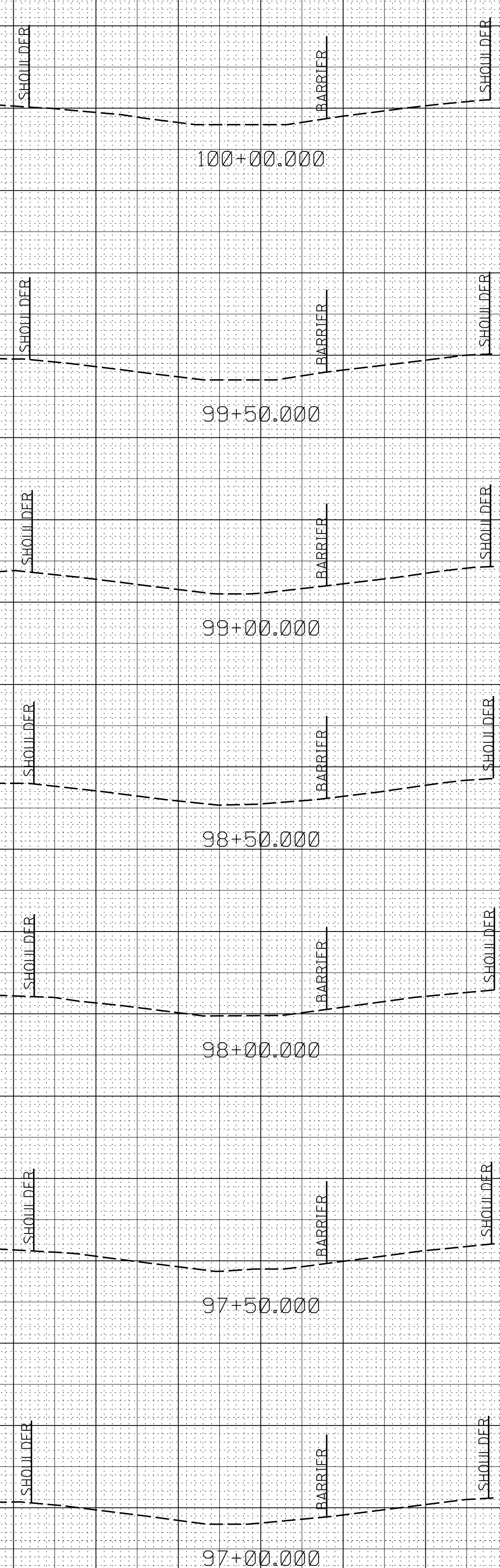

340
335
330
340
335
330
340
335
330
340
335
330
340
335
330

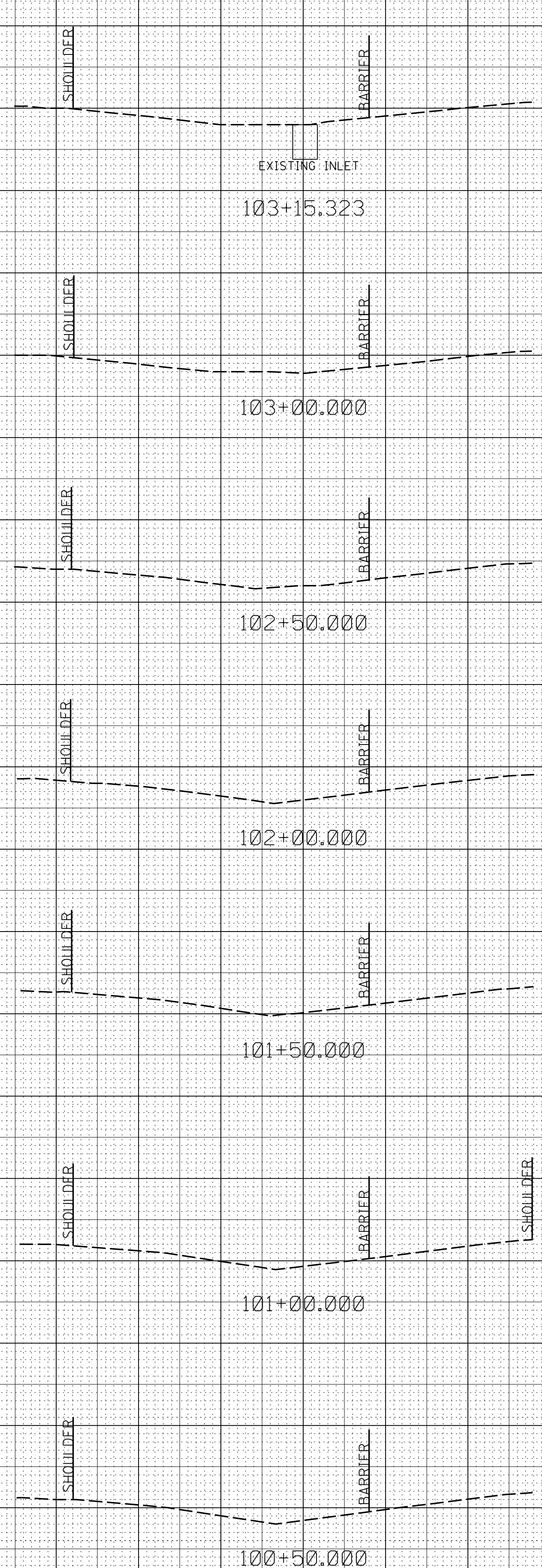

7/30/2019 8:35 AM LAY-HOLMES3.DGN

80 60 40 20 0 20 40 60 80 80 60 40 20 0 20 40

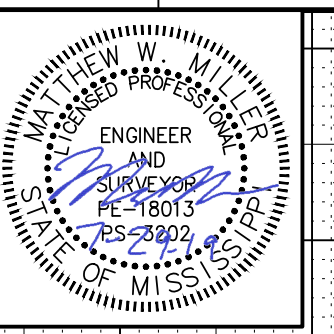

350

345

340

SHOULDER

106+50.000

BARRIER

355

350

345

SHOULDER

110+00.000

BARRIER

345

340

SHOULDER

106+00.000

BARRIER

350

345

SHOULDER

109+50.000

BARRIER

345

340

SHOULDER

105+50.000

BARRIER

350

345

SHOULDER

109+00.000

BARRIER

345

340

SHOULDER

105+00.000

BARRIER

350

345

SHOULDER

108+50.000

BARRIER

345

340

335

SHOULDER

104+50.000

BARRIER

350

345

340

SHOULDER

108+00.000

BARRIER

345

340

335

SHOULDER

104+00.000

BARRIER

350

345

340

SHOULDER

107+50.000

BARRIER

345

340

335

SHOULDER

103+50.000

BARRIER

350

345

340

SHOULDER

107+00.000

BARRIER

7/30/2019 8:35 AM LAY-HOLMES3.DGN

80 60 40 20 0 20 40 60 80 80 60 40 20 0 20 40

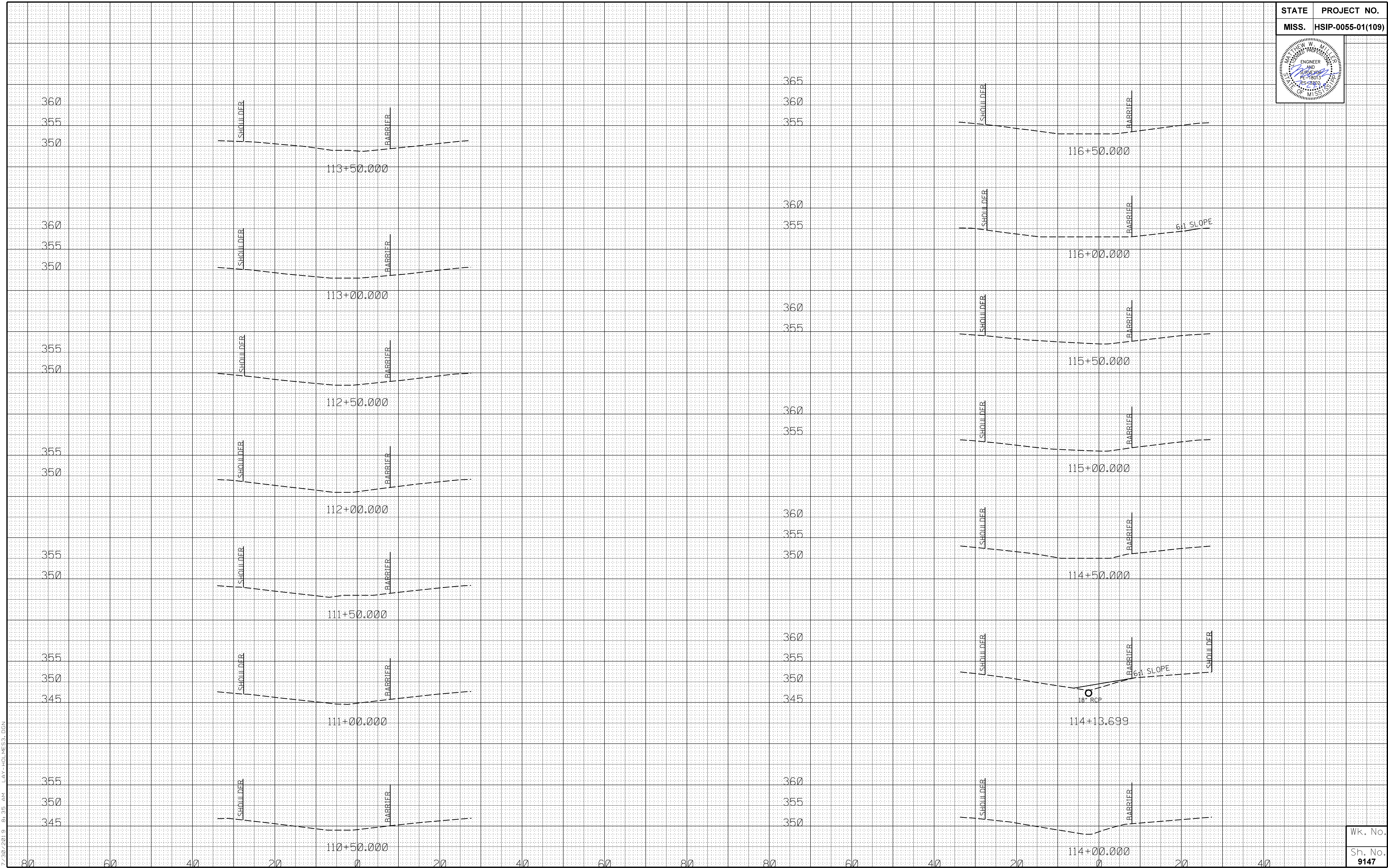
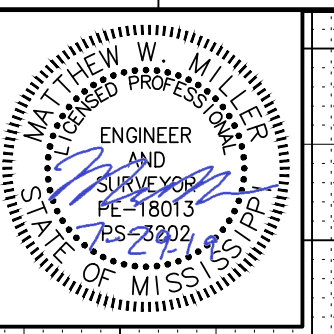

7/30/2019 8:35 AM LAY-HOLMES3.DGN

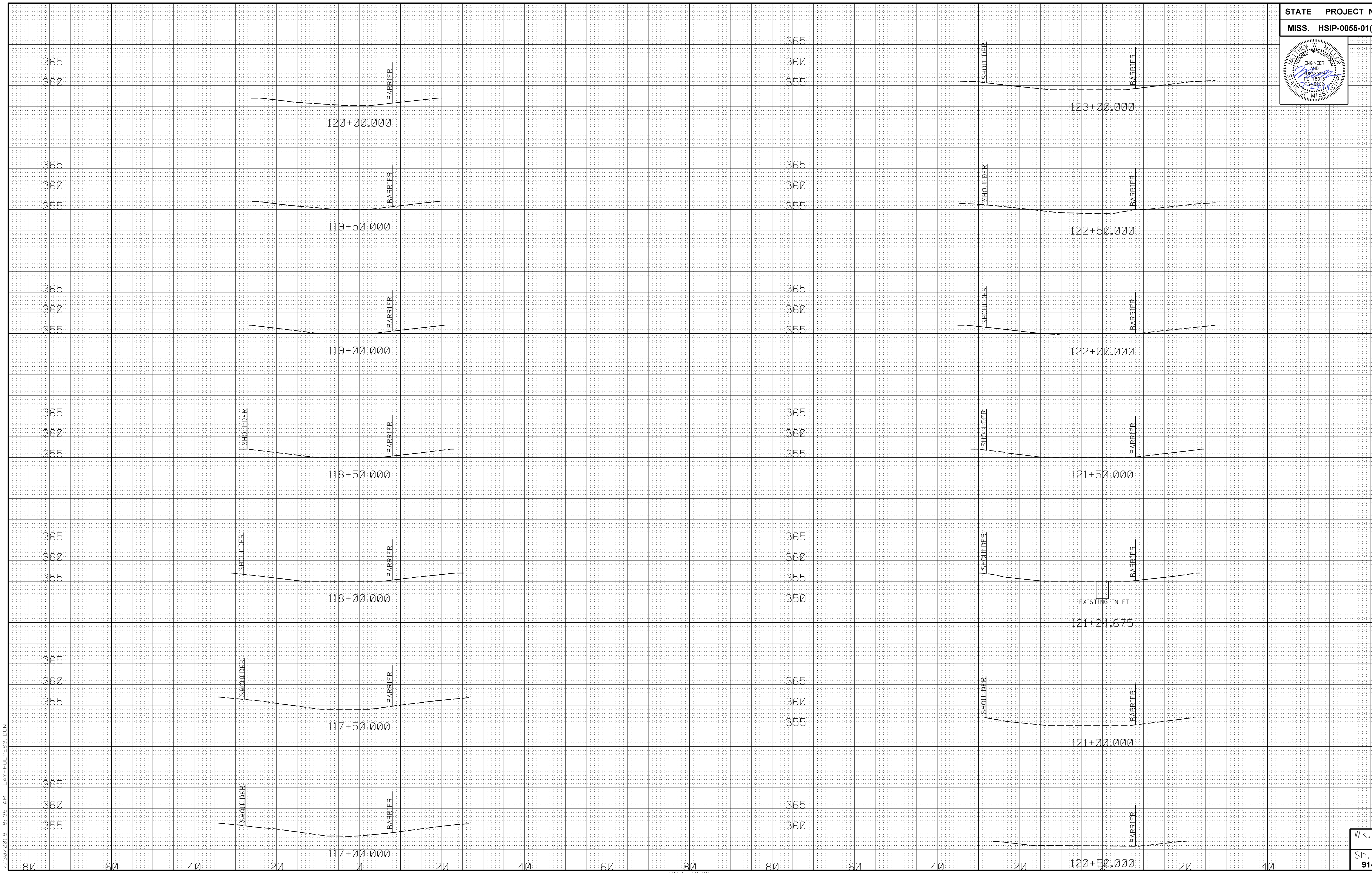
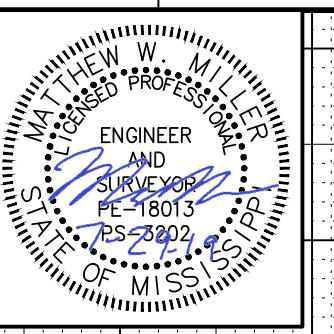

7/30/2019 8:35 AM LAY-HOLMES3.DGN

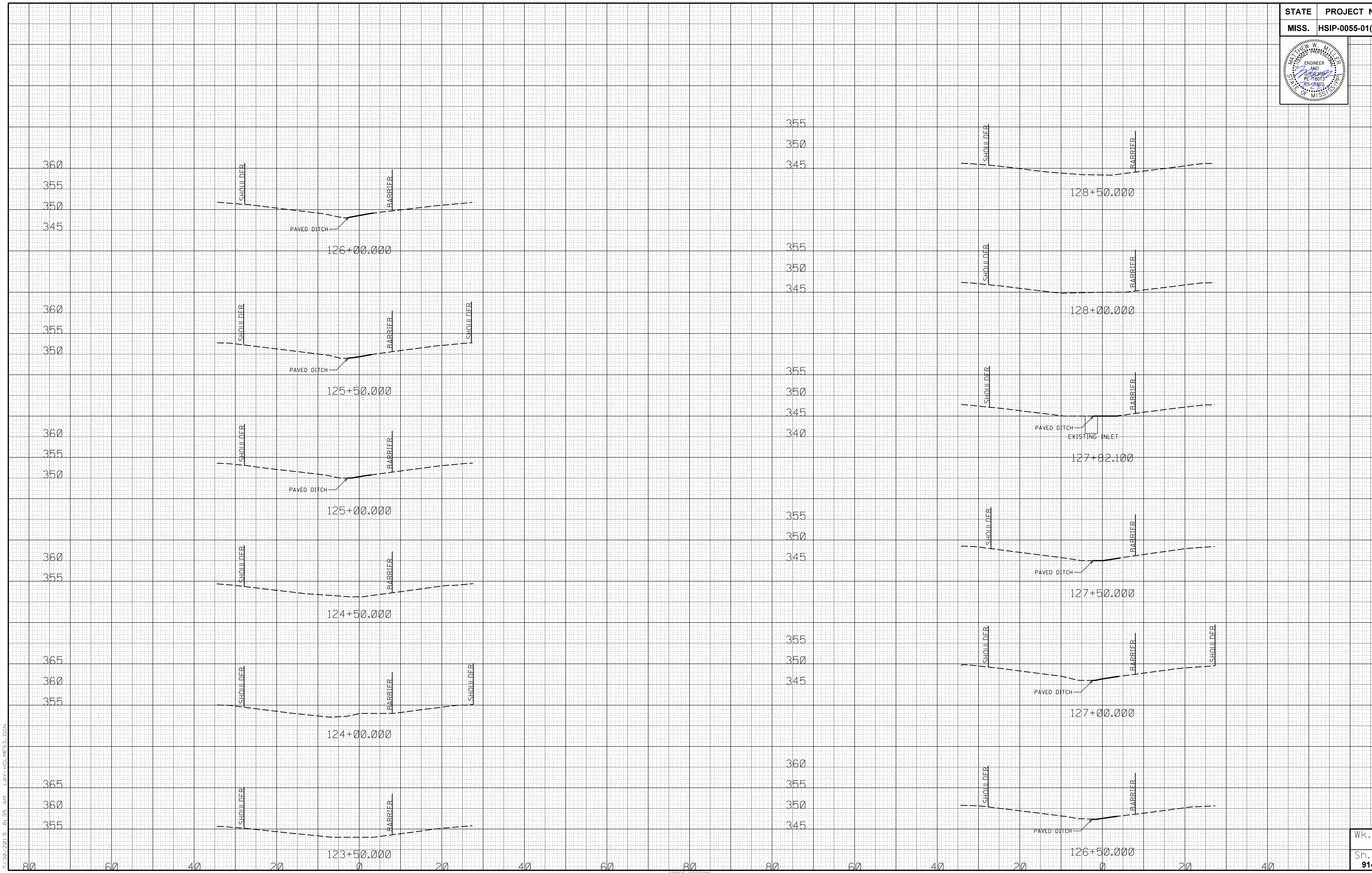
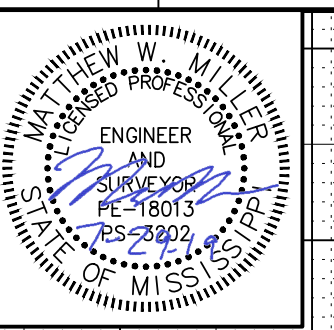

7/30/2019 8:35 AM LAY-HOLMES3.DGN

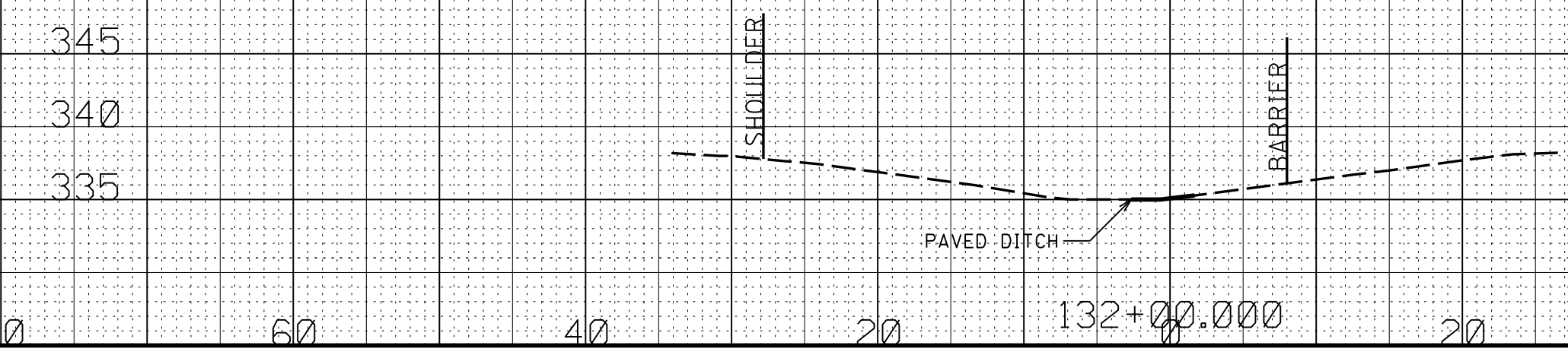
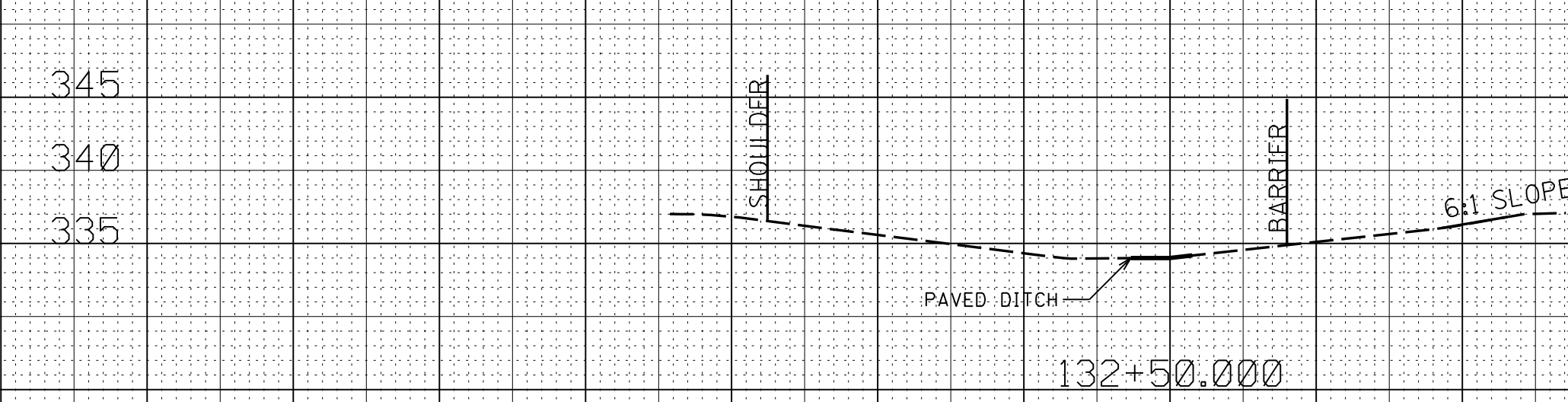
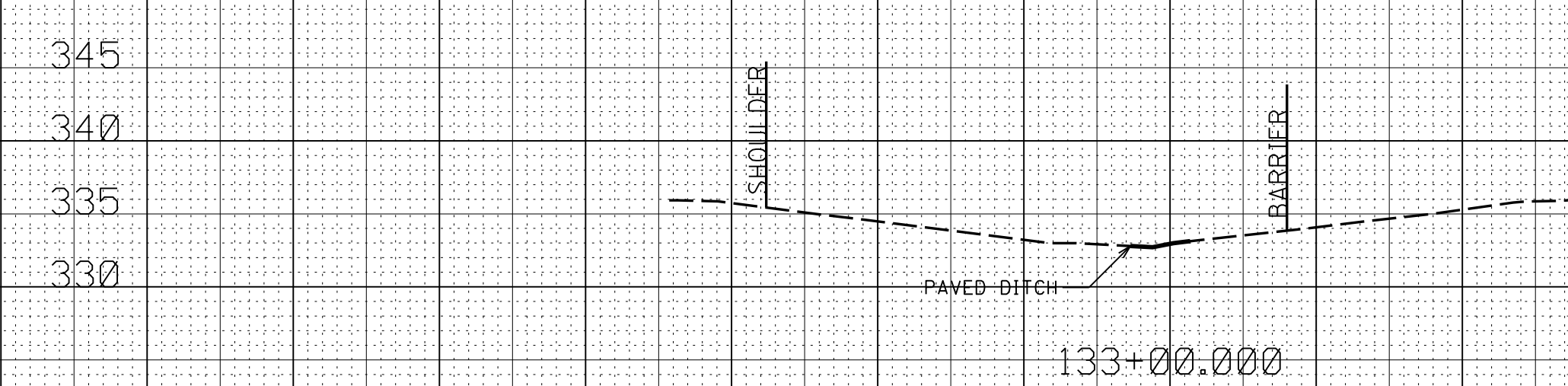
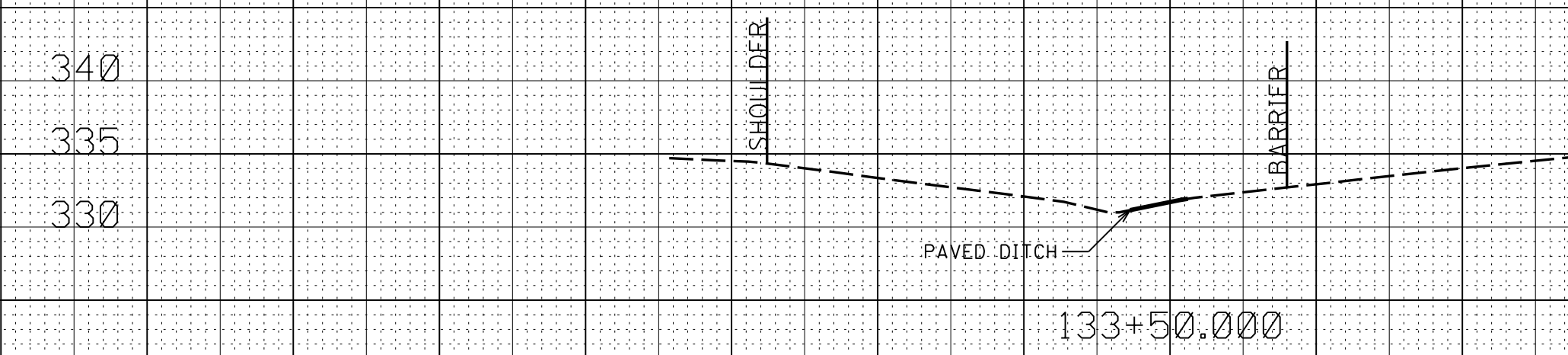
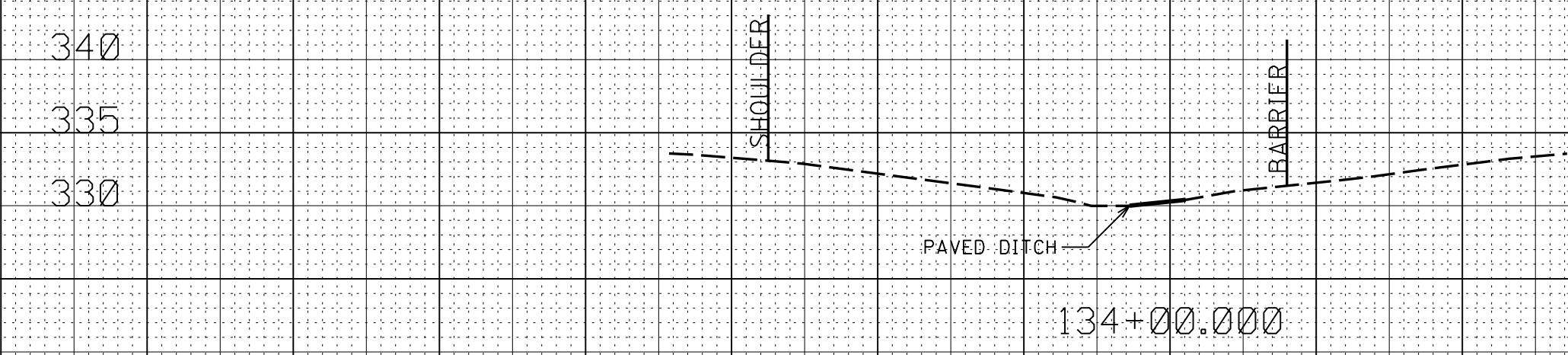
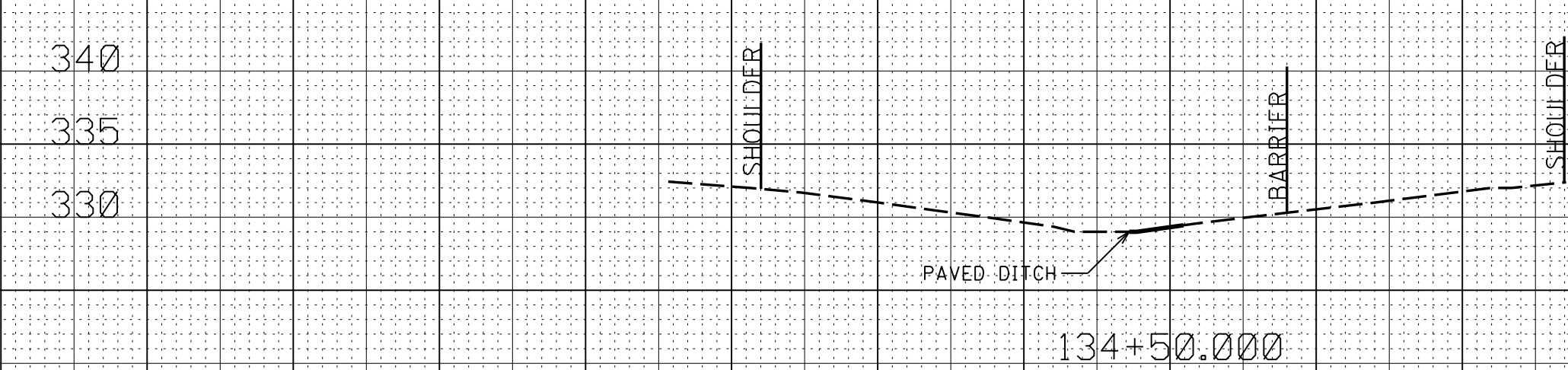
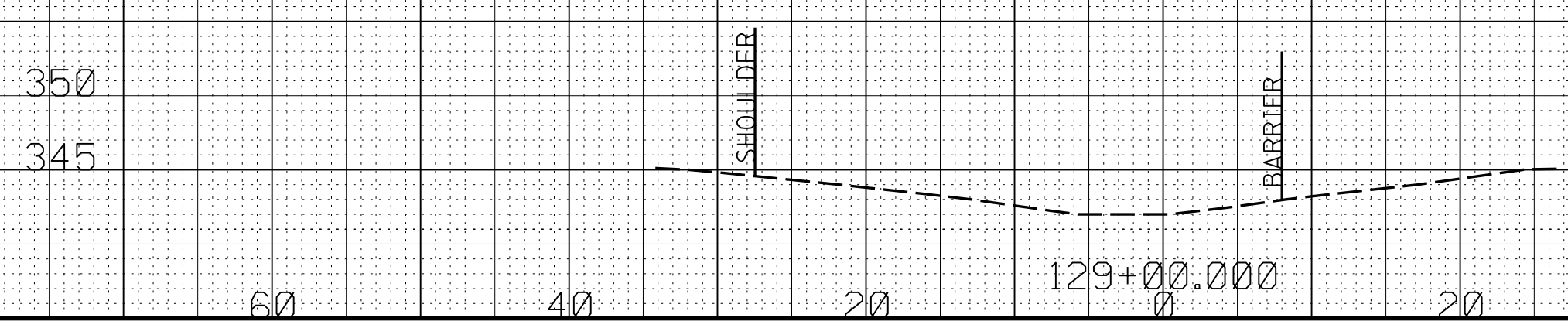
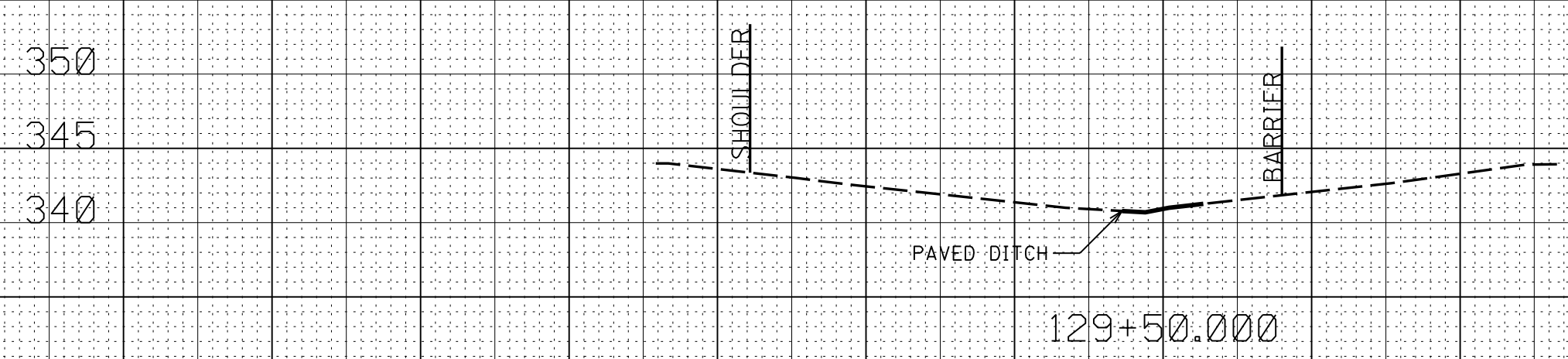
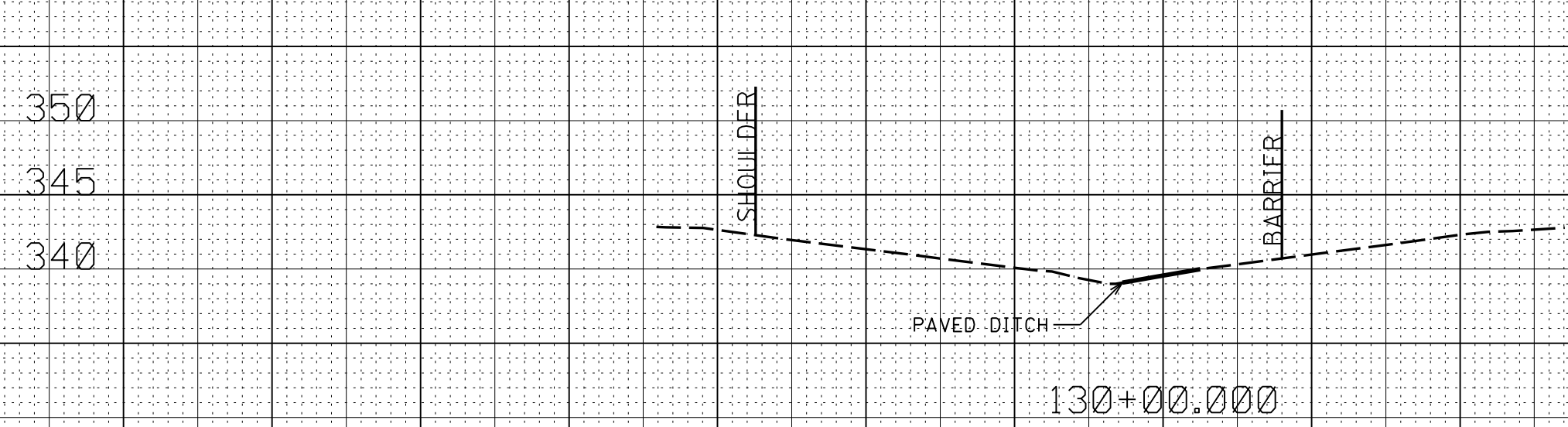
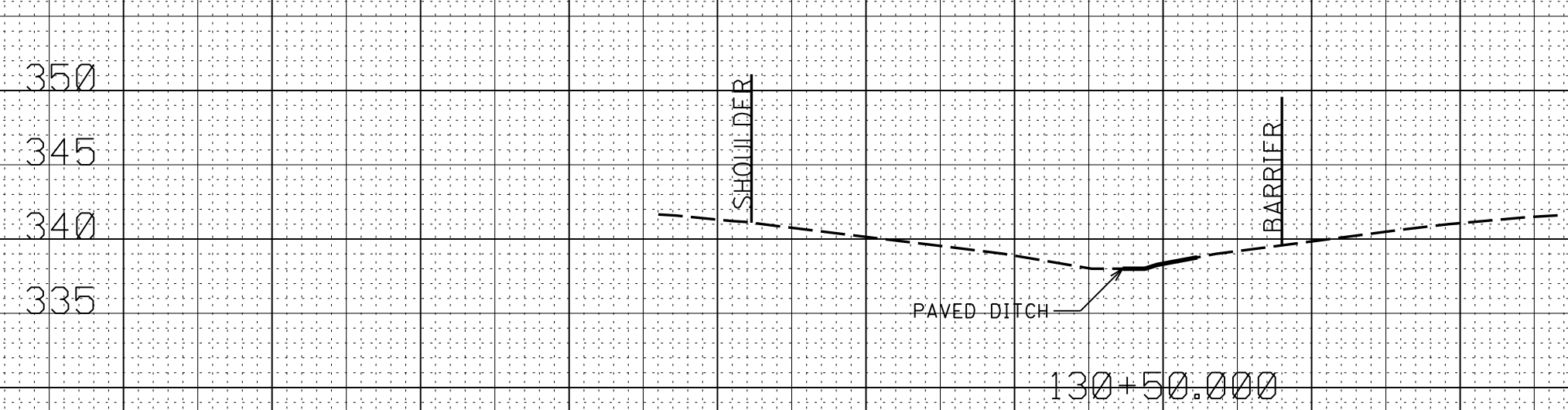
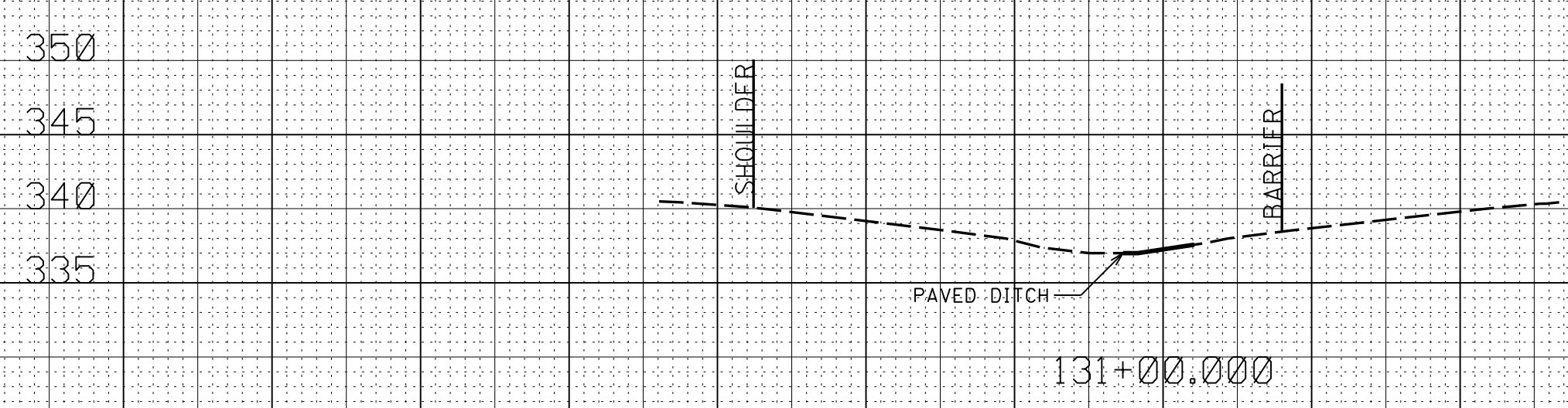
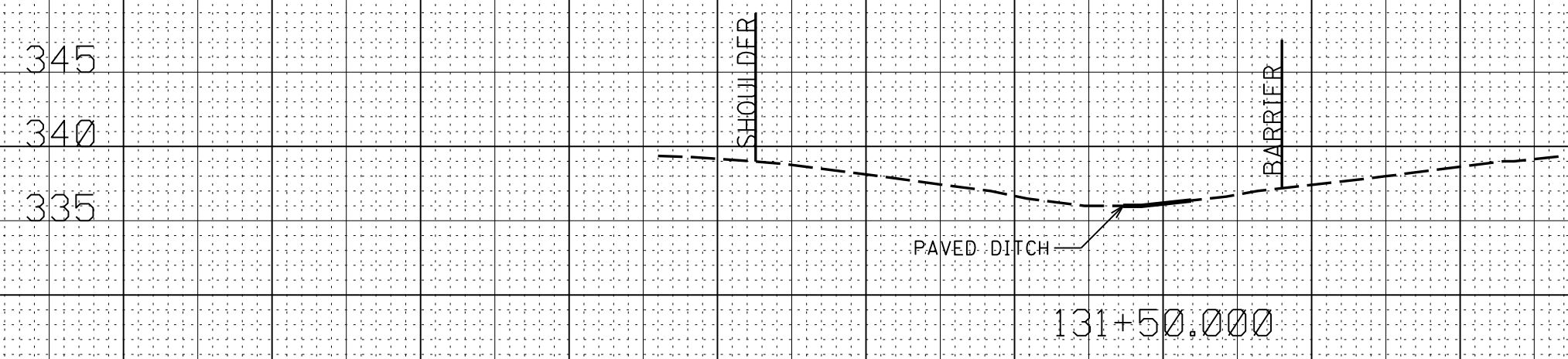
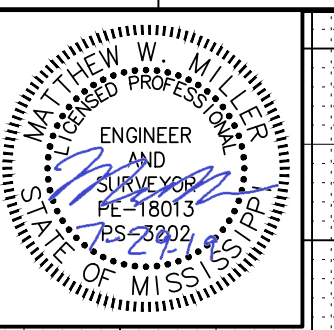

7/30/2019 8:35 AM LAY-HOLMES3.DGN

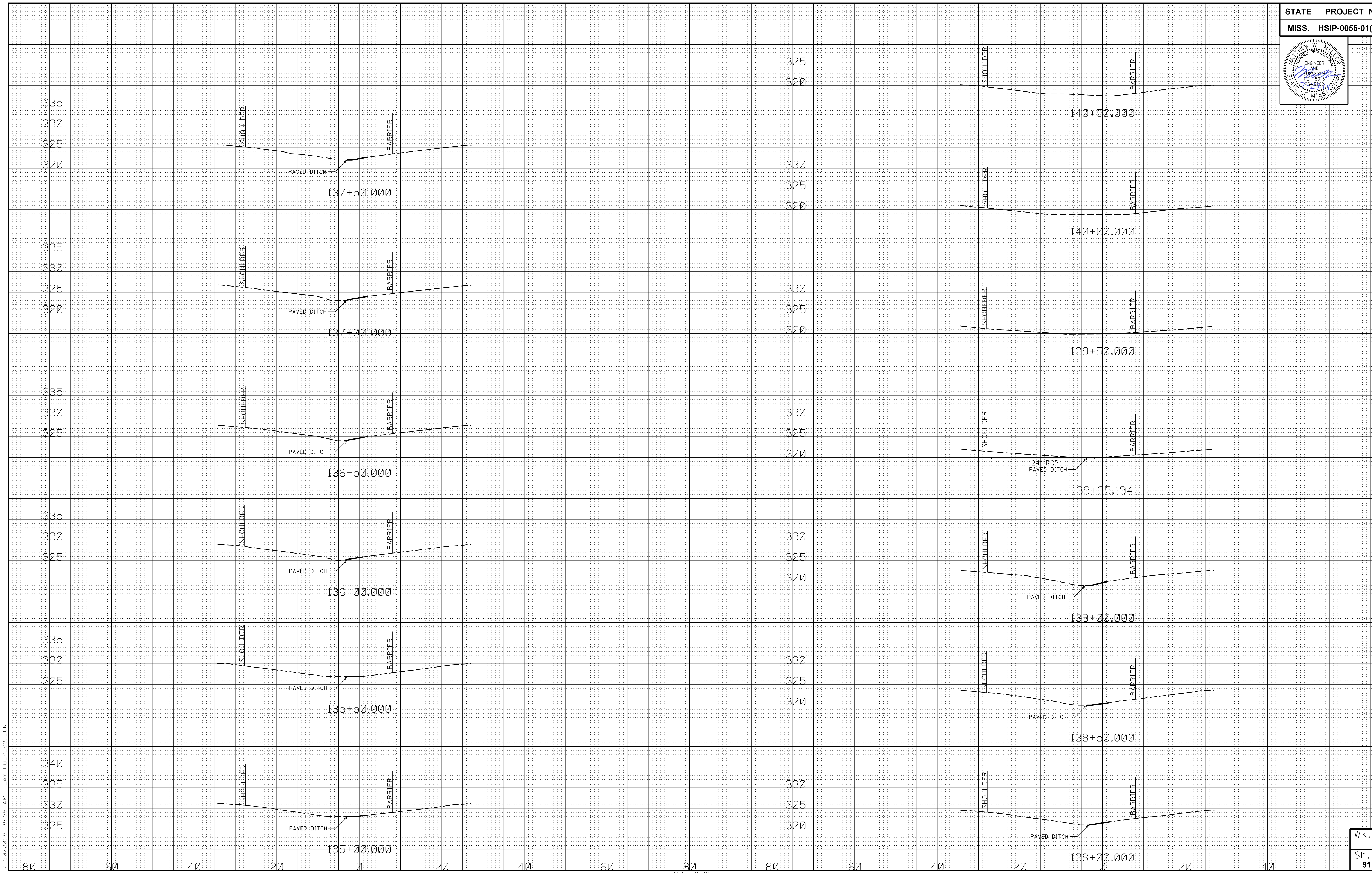
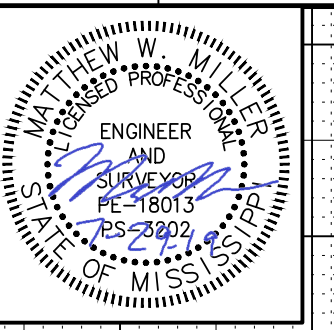

7/30/2019 8:35 AM LAY-HOLMES3.DGN

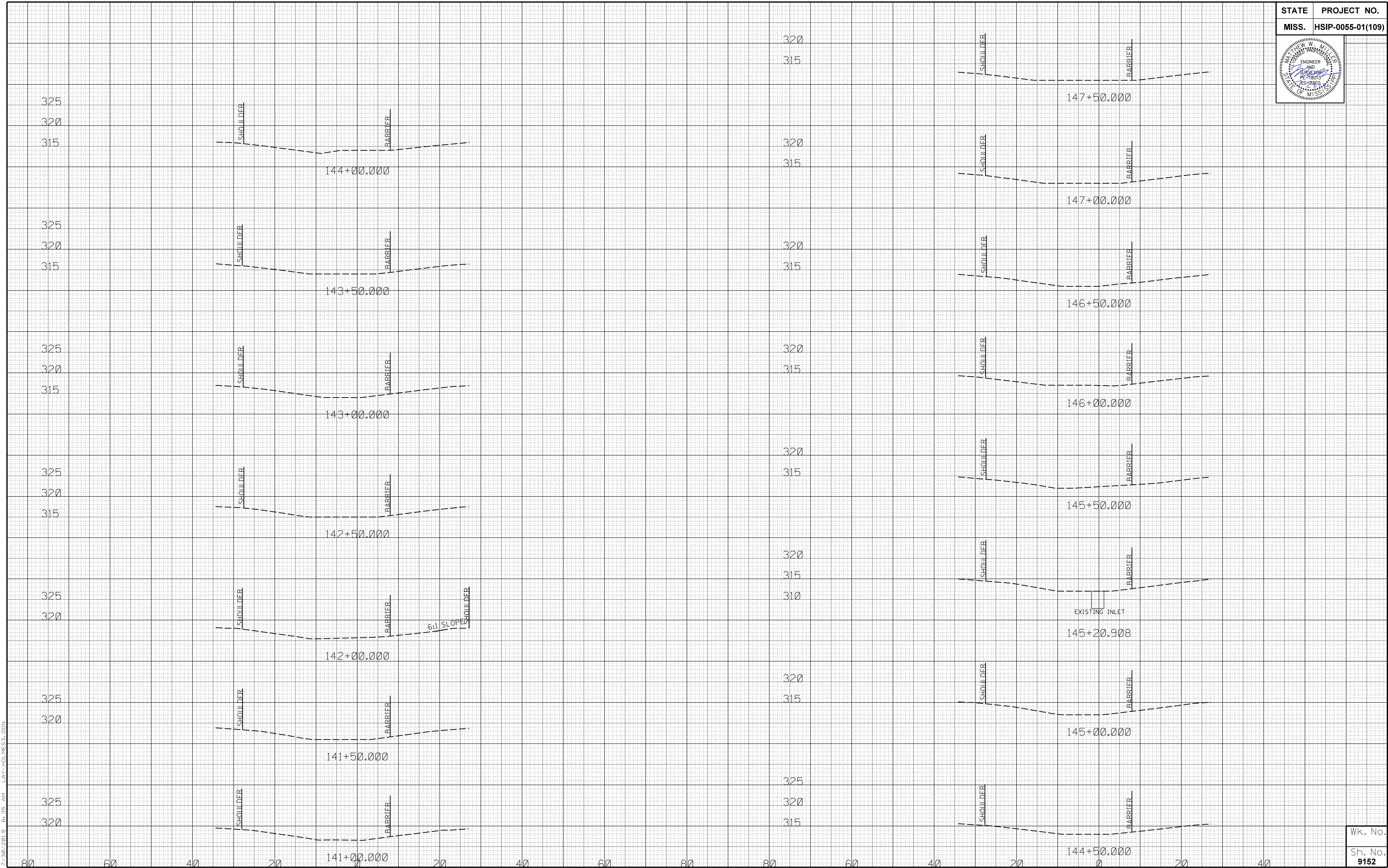
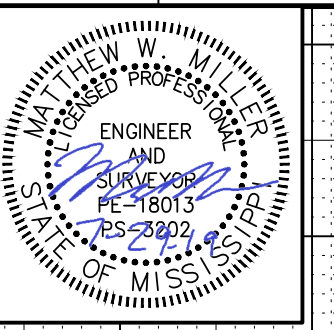

7/30/2019 8:35 AM LAY-HOLMES3.DGN

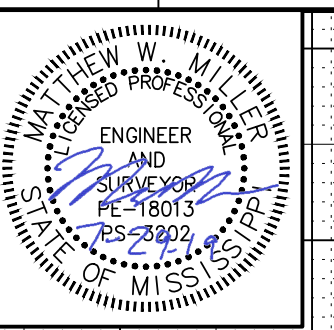

315
310
320
315
310
320
315
310
320
315
310
320
315
310
320
315
310
320
315
310
320
315
310

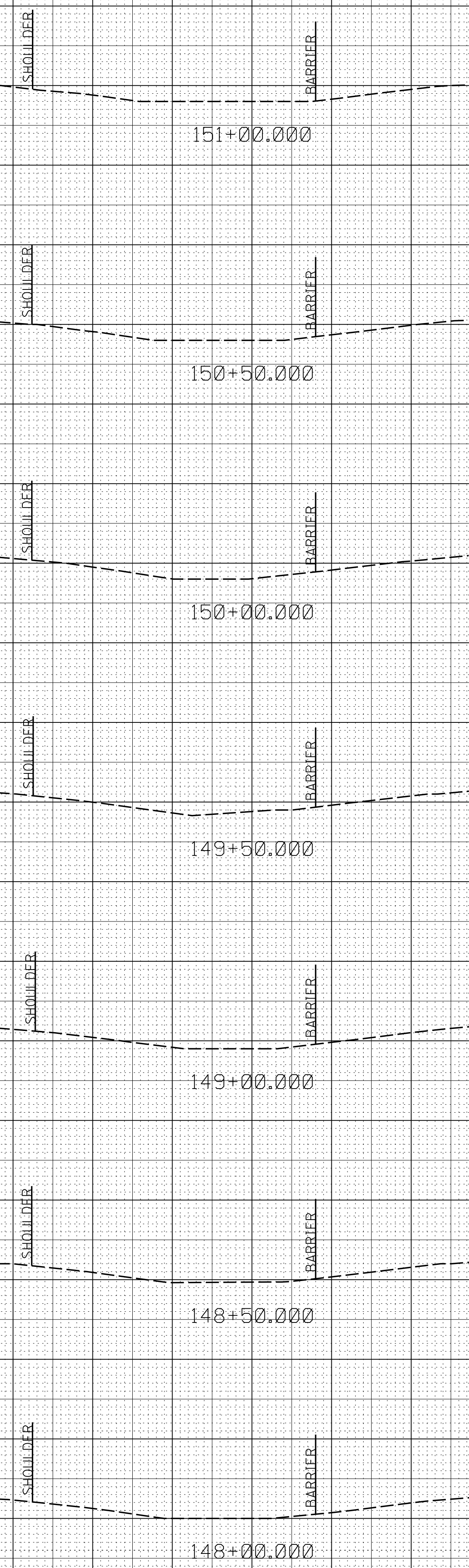

315
310
305
300
315
310
305
300
315
310
305
300
315
310
305
300
315
310
305
300
315
310
305
300

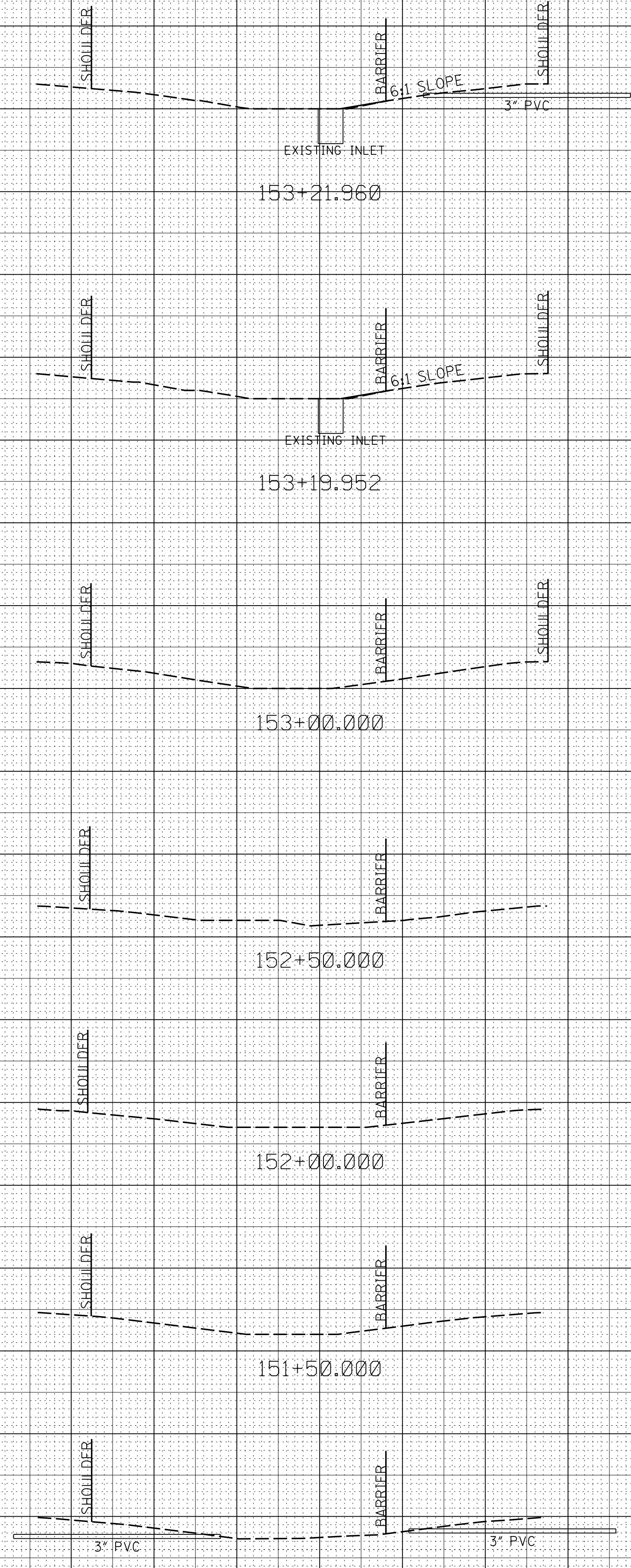

7/30/2019 8:35 AM LAY-HOLMES3.DGN

80 60 40 20 0 20 40 60 80 80 60 40 20 151+21.336 20 40

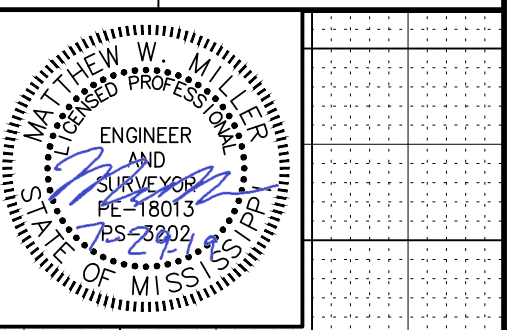

315
310
305
315
310
305
315
310
305
315
310
305
315
310
305
315
310
305
315
310
305

310
305
315
310
305
315
310
305
315
310
305
315
310
305
315
310
305
315
310
305

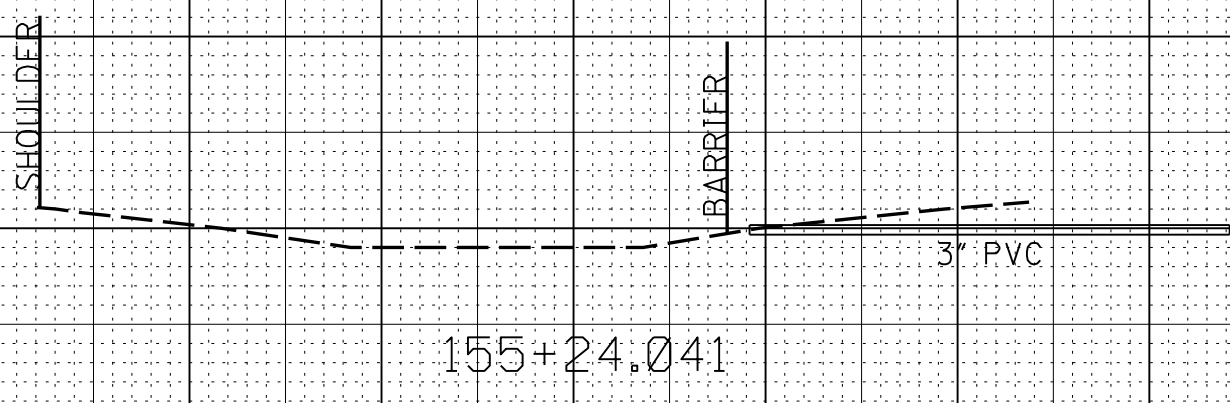

155+24.041

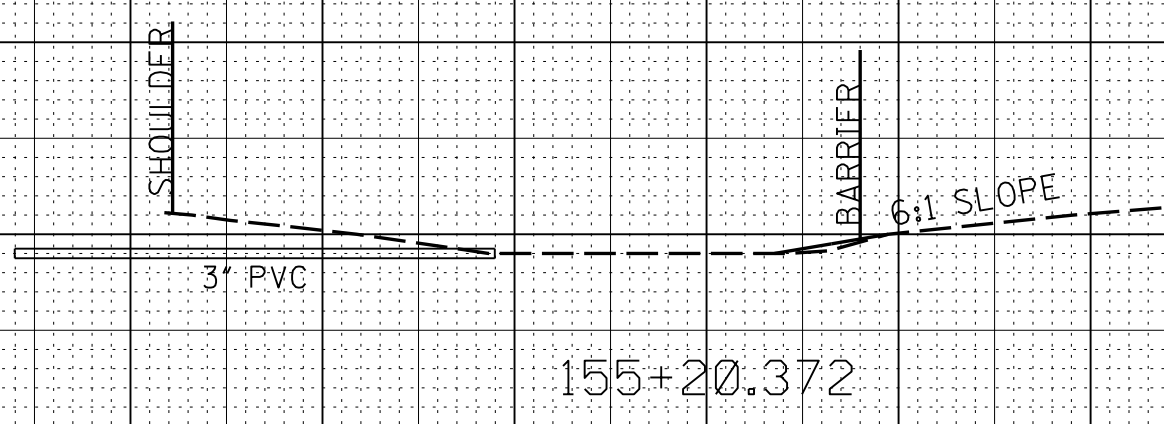

155+20.372

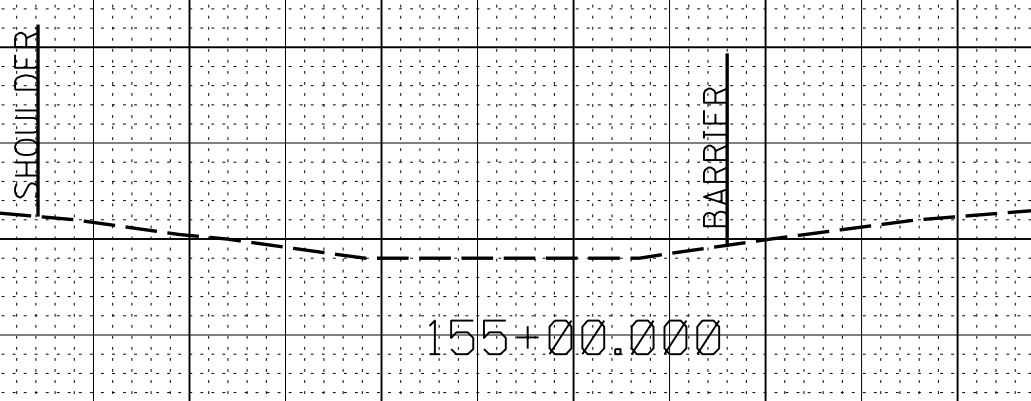

155+00.000

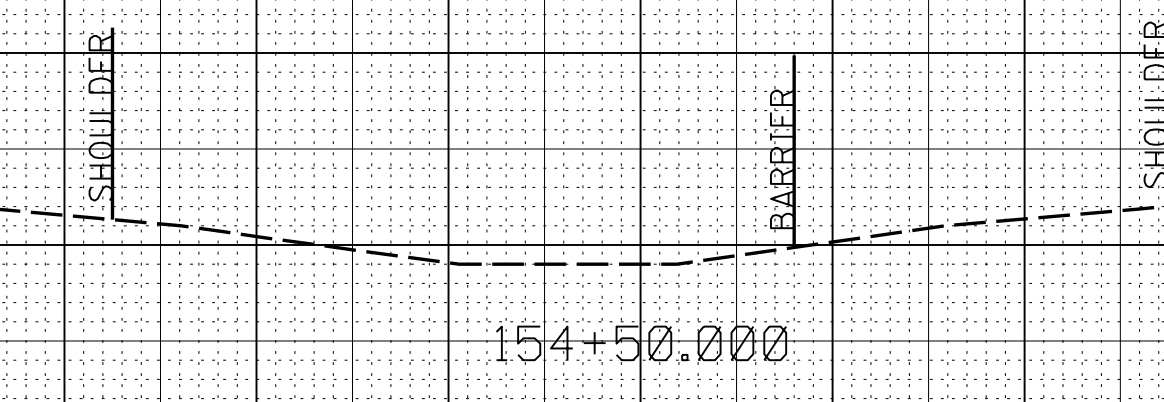

154+50.000

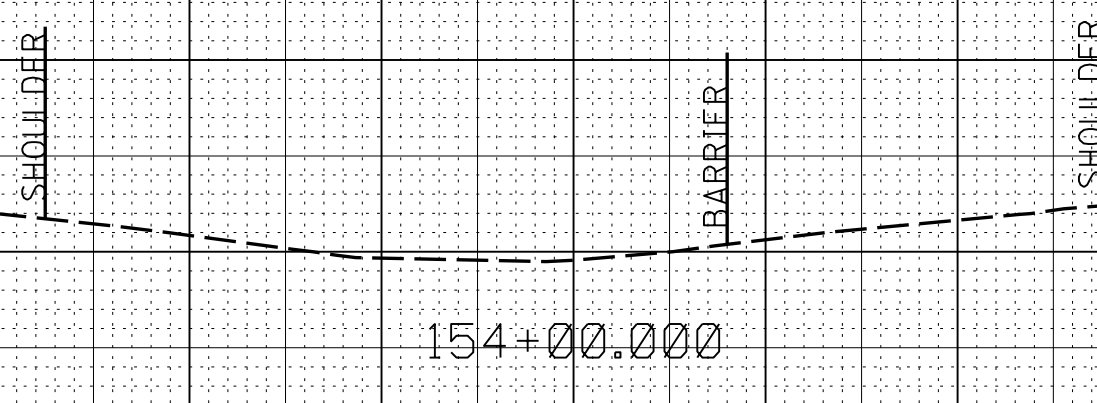

154+00.000

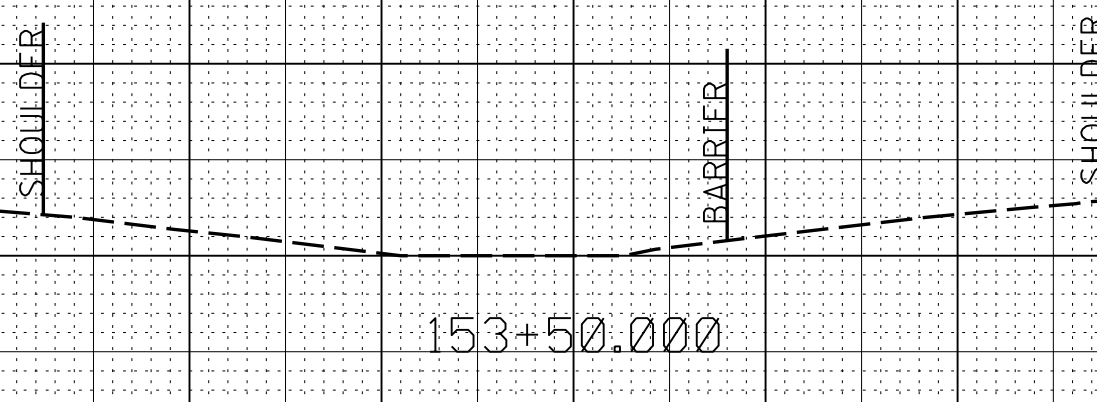

153+50.000

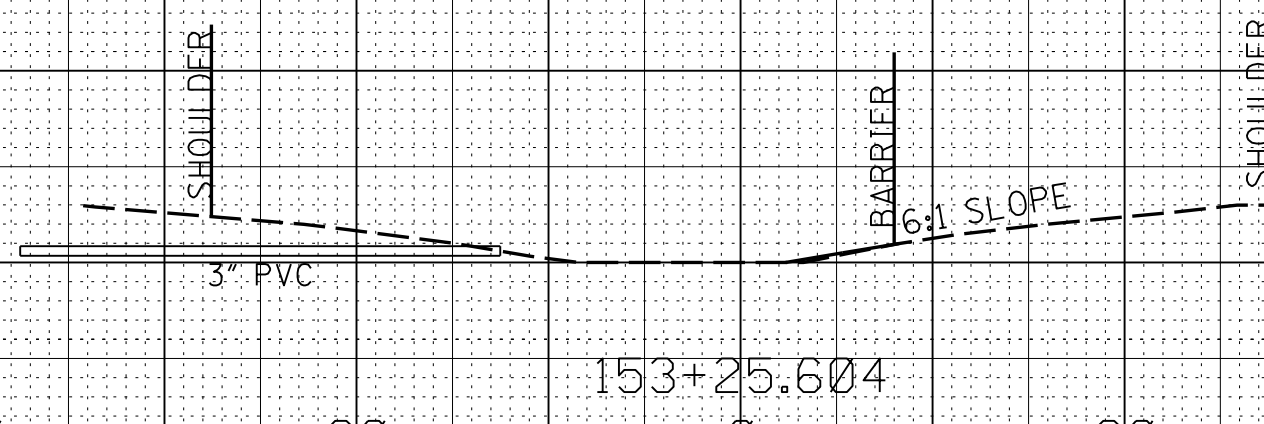

153+25.604

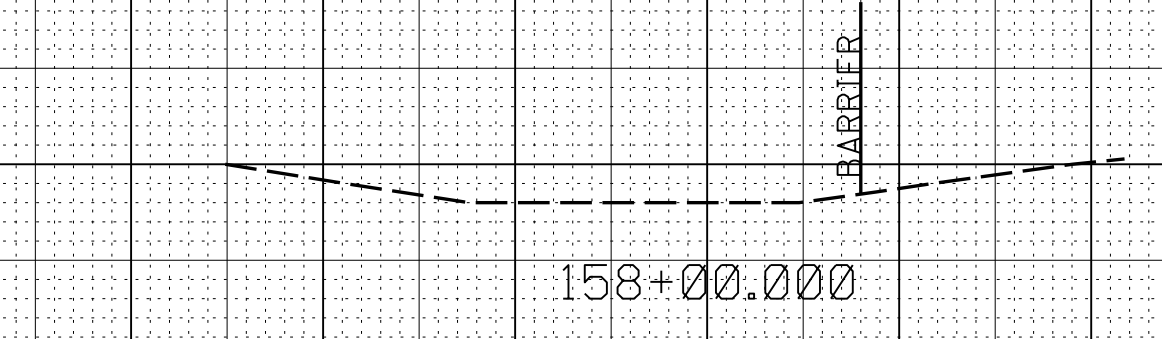

158+00.000

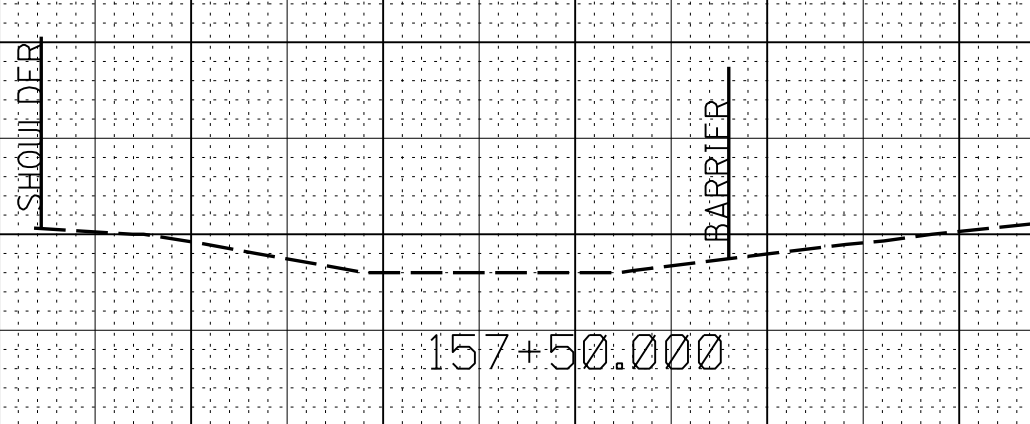

157+50.000

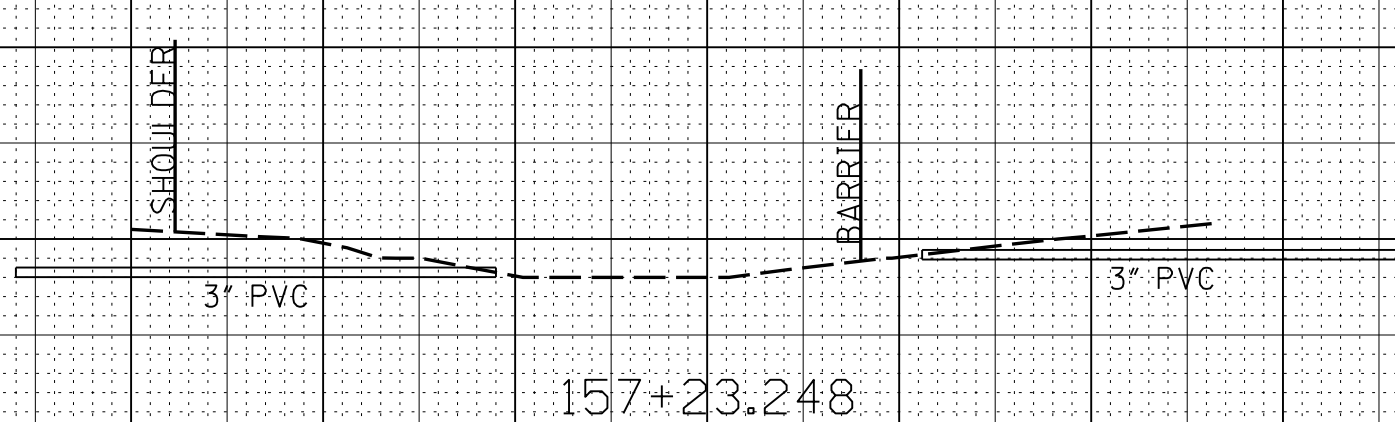

157+23.248

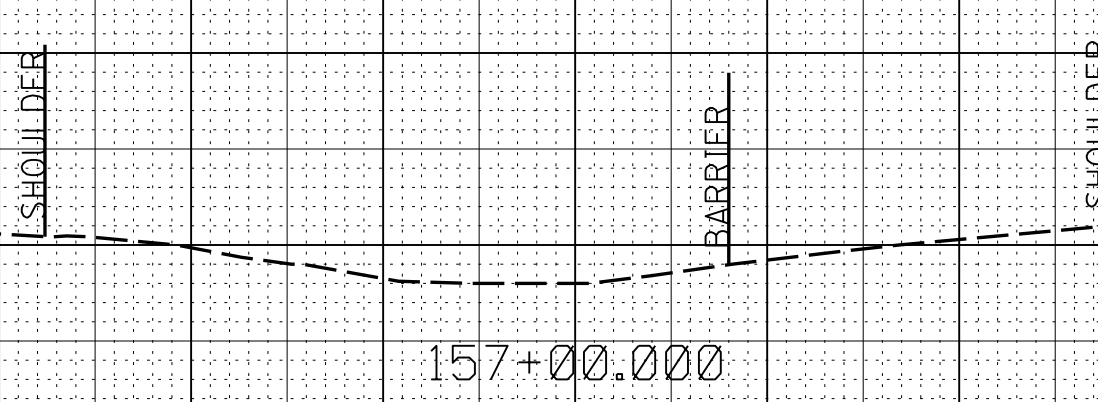

157+00.000

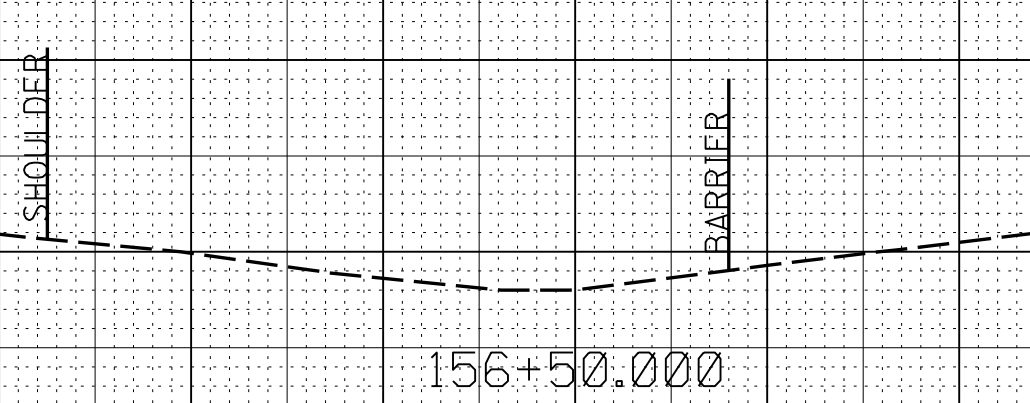

156+50.000

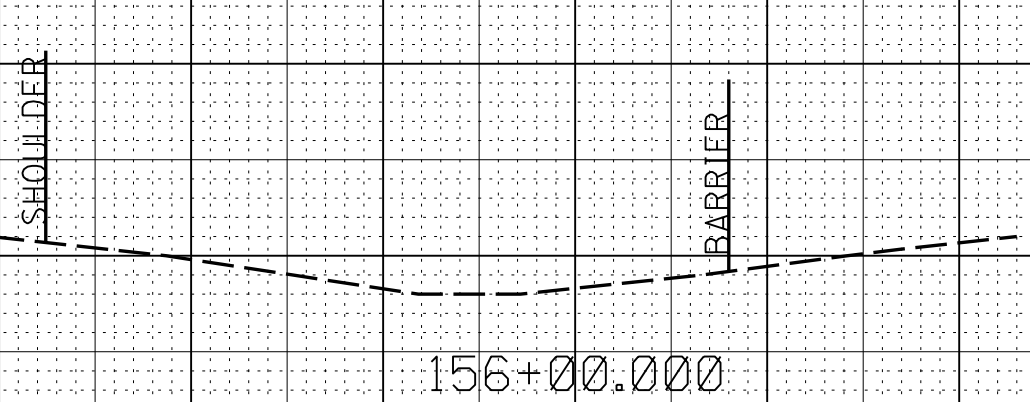

156+00.000

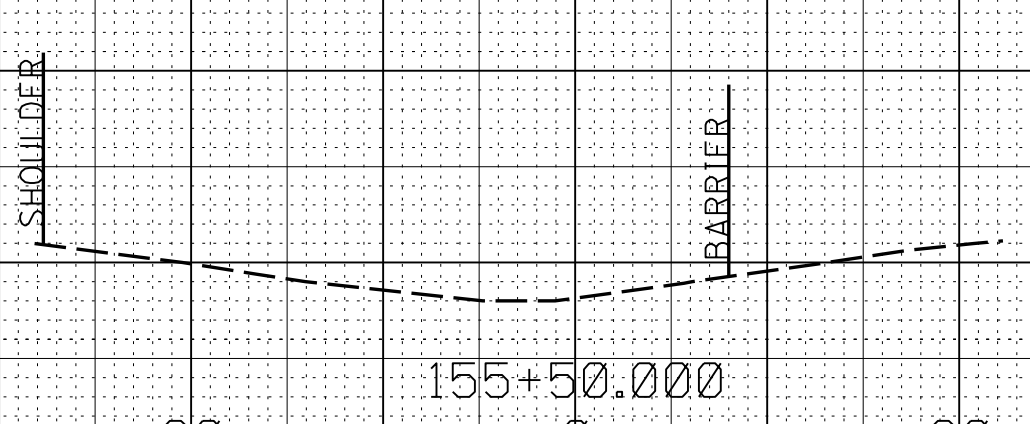

155+50.000

7/30/2019 8:35 AM LAY-HOLMES3.DGN

80 60 40 20 0 20 40 60 80 80 60 40 20 0 20 40

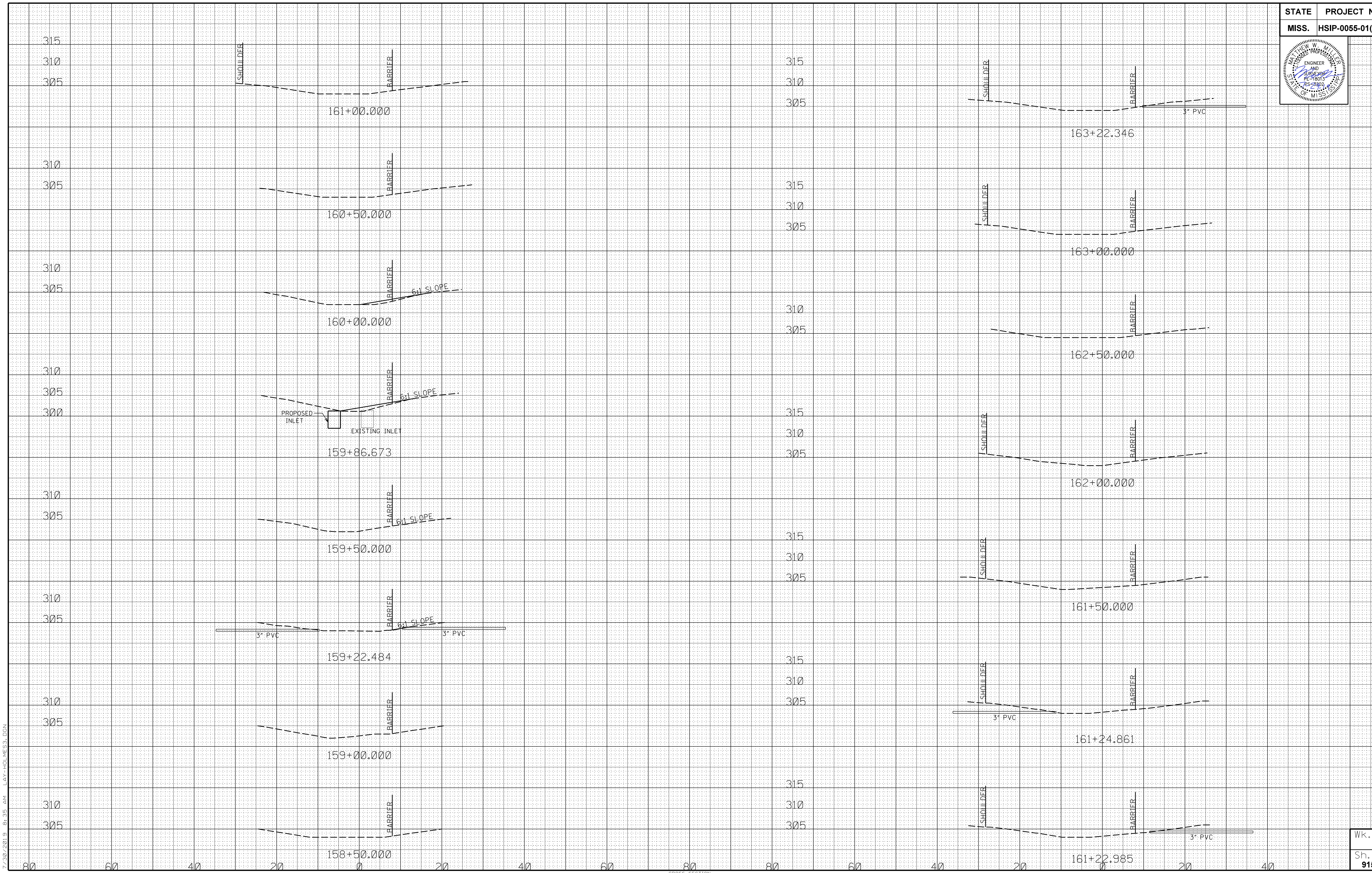
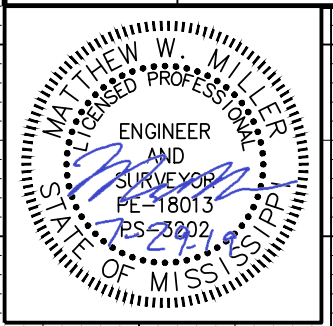

7/30/2019 8:35 AM LAY-HOLMES3.DGN

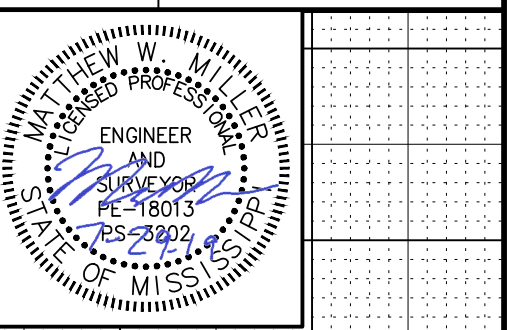

315
310
305
315
310
305
315
310
305
315
310
305
315
310
305
315
310
305
315
310
305



165+24.588

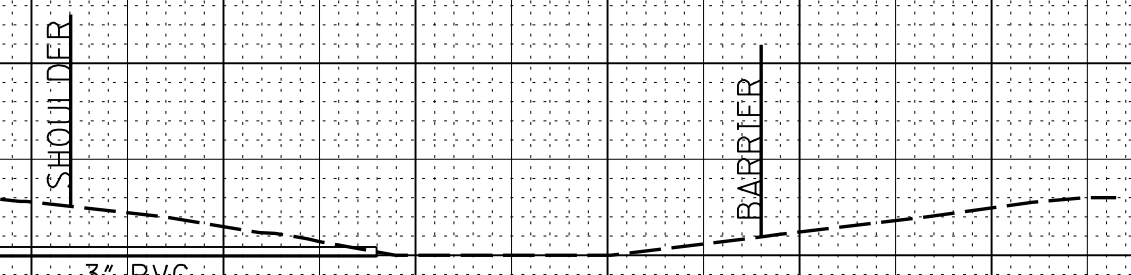

165+23.513

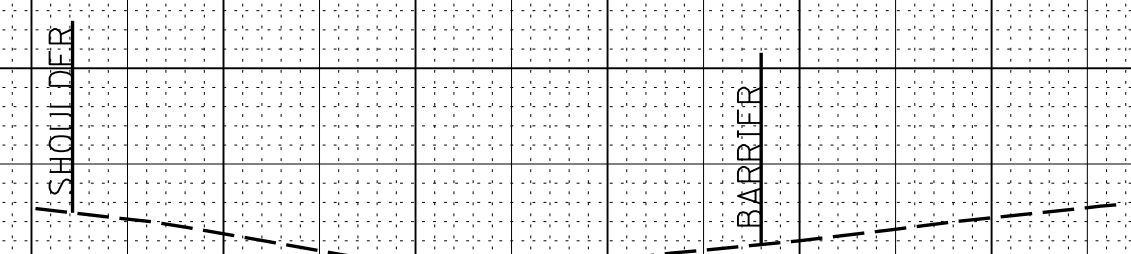

165+00.000

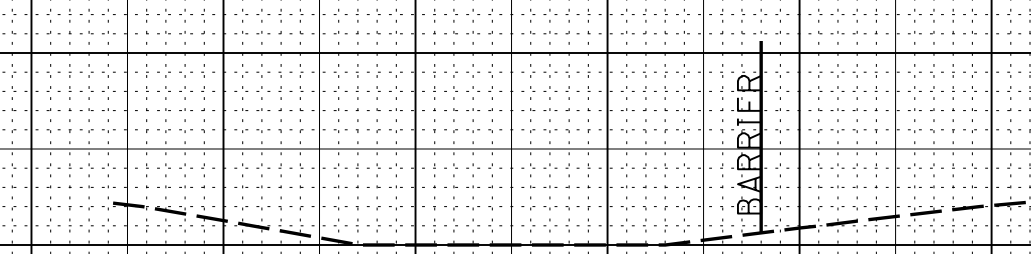

164+50.000

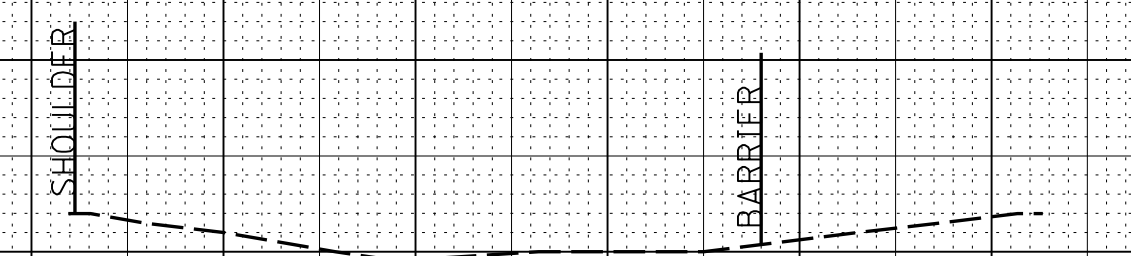

164+00.000

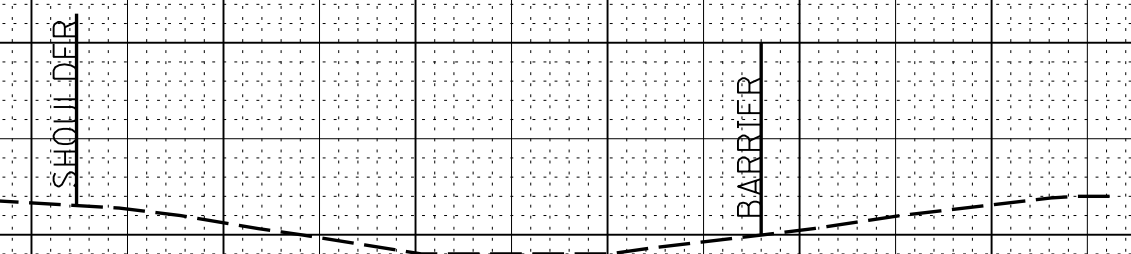

163+50.000

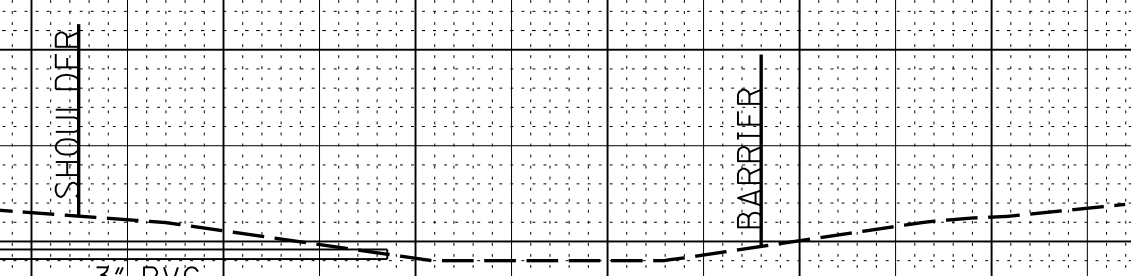

163+23.974

315
310
315
310
305
315
310
305
315
310
305
315
310
305
315
310
305
315
310
305

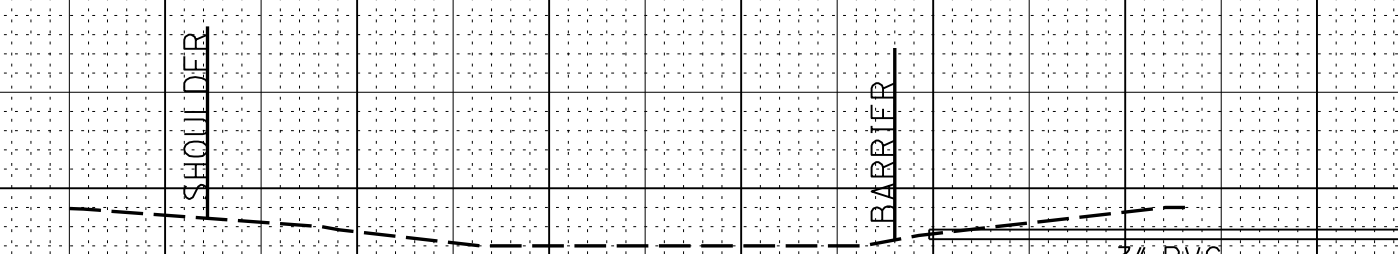

167+22.136

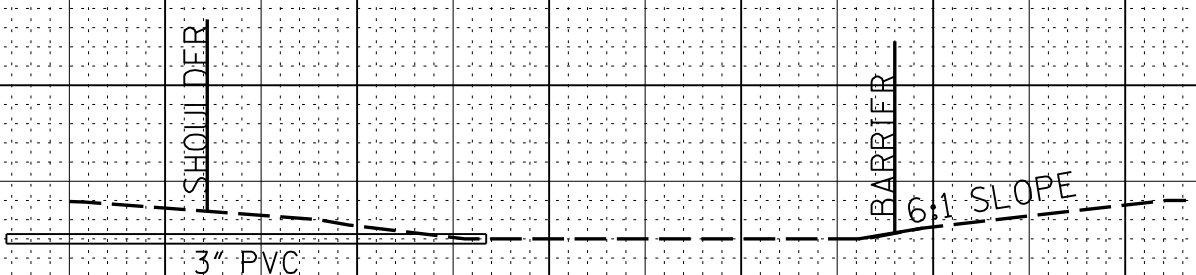

167+21.505

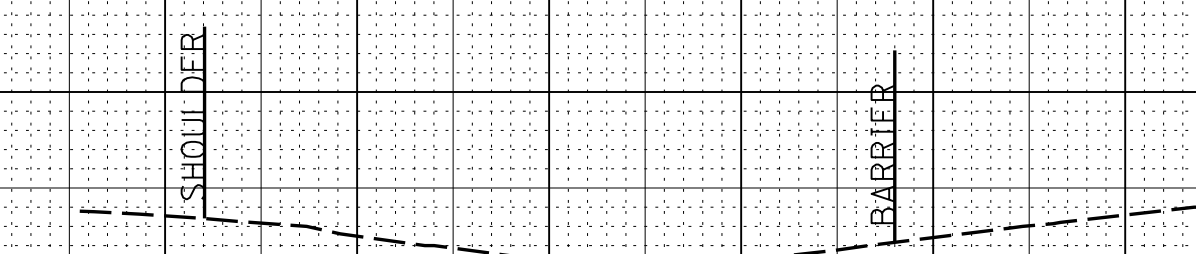

167+00.000

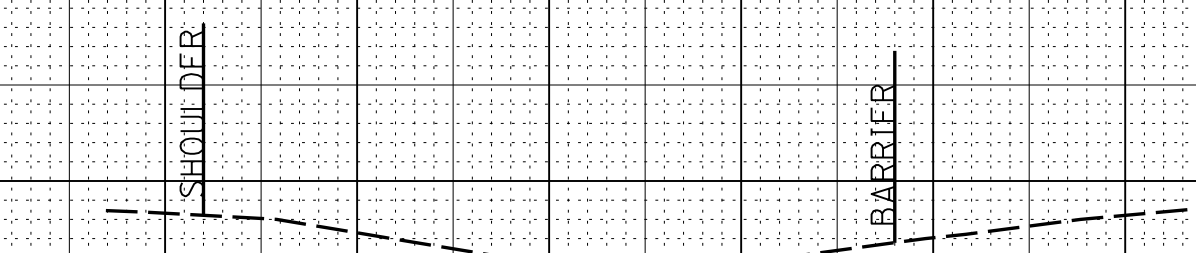

166+50.000

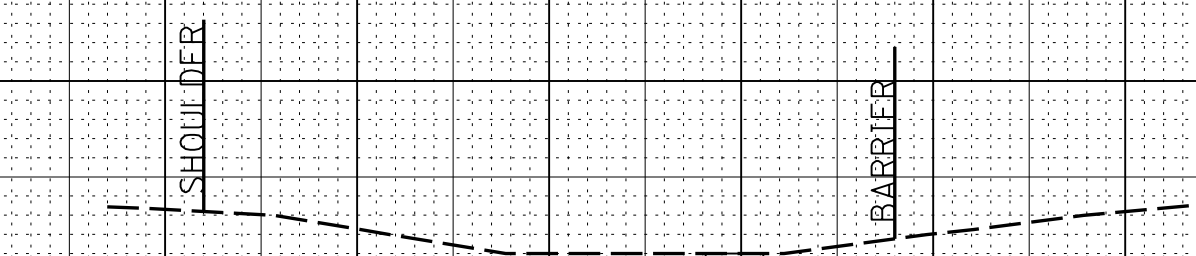

166+47.834

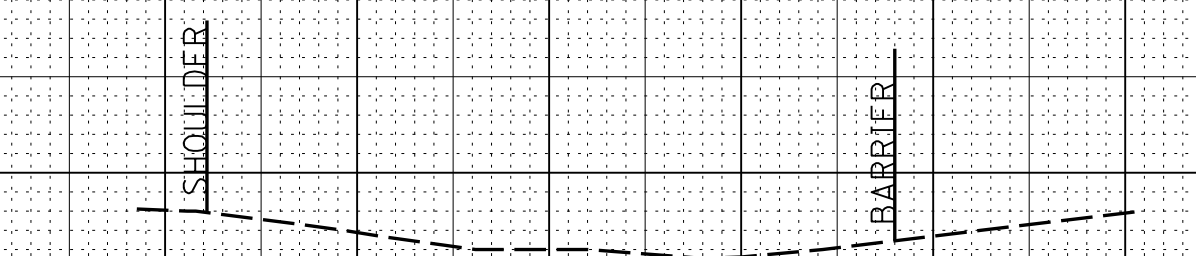

166+00.000

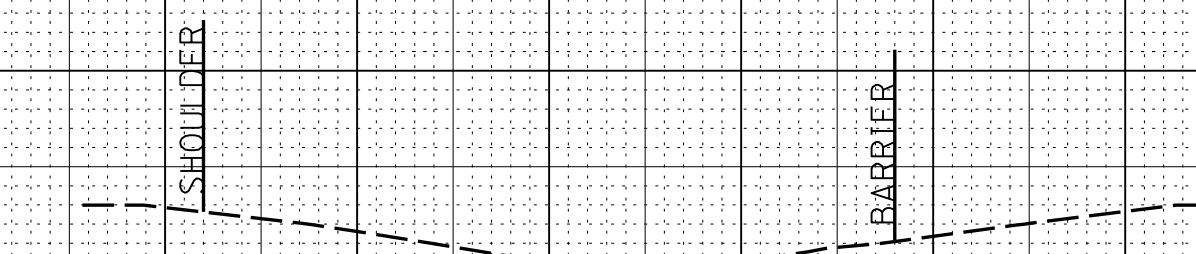

165+50.000

7/20/2019 8:35 AM LAY-HOLMES3.DGN

80 60 40 20 0 20 40 60 80 80 60 40 20 0 20 40

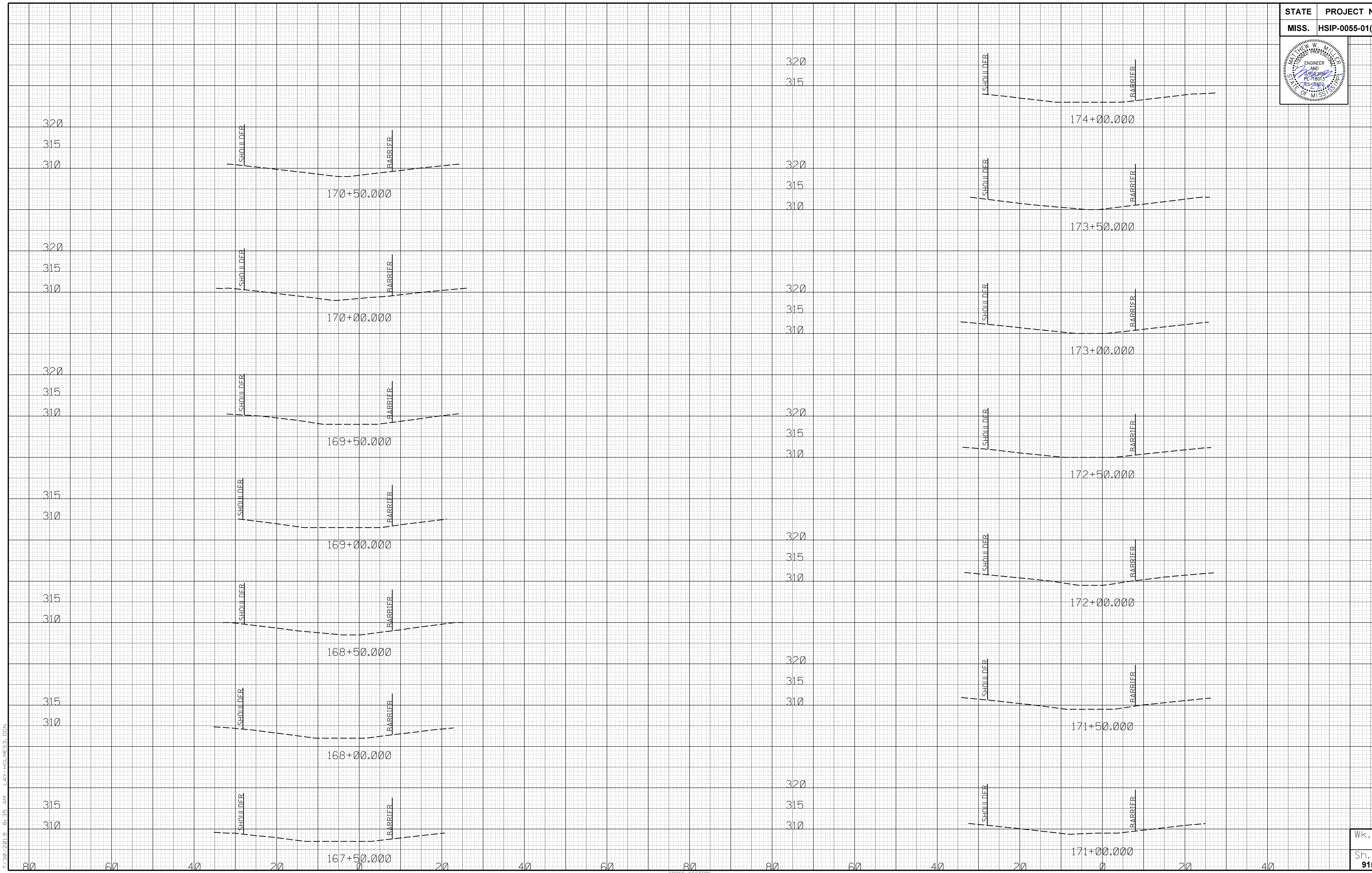
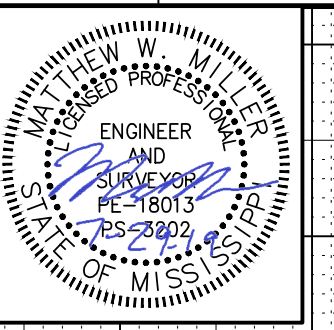

7/30/2019 8:35 AM LAY-HOLMES3.DGN

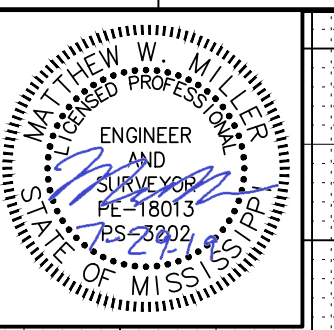

7/30/2019 8:35 AM LAY-HOLMES3.DGN

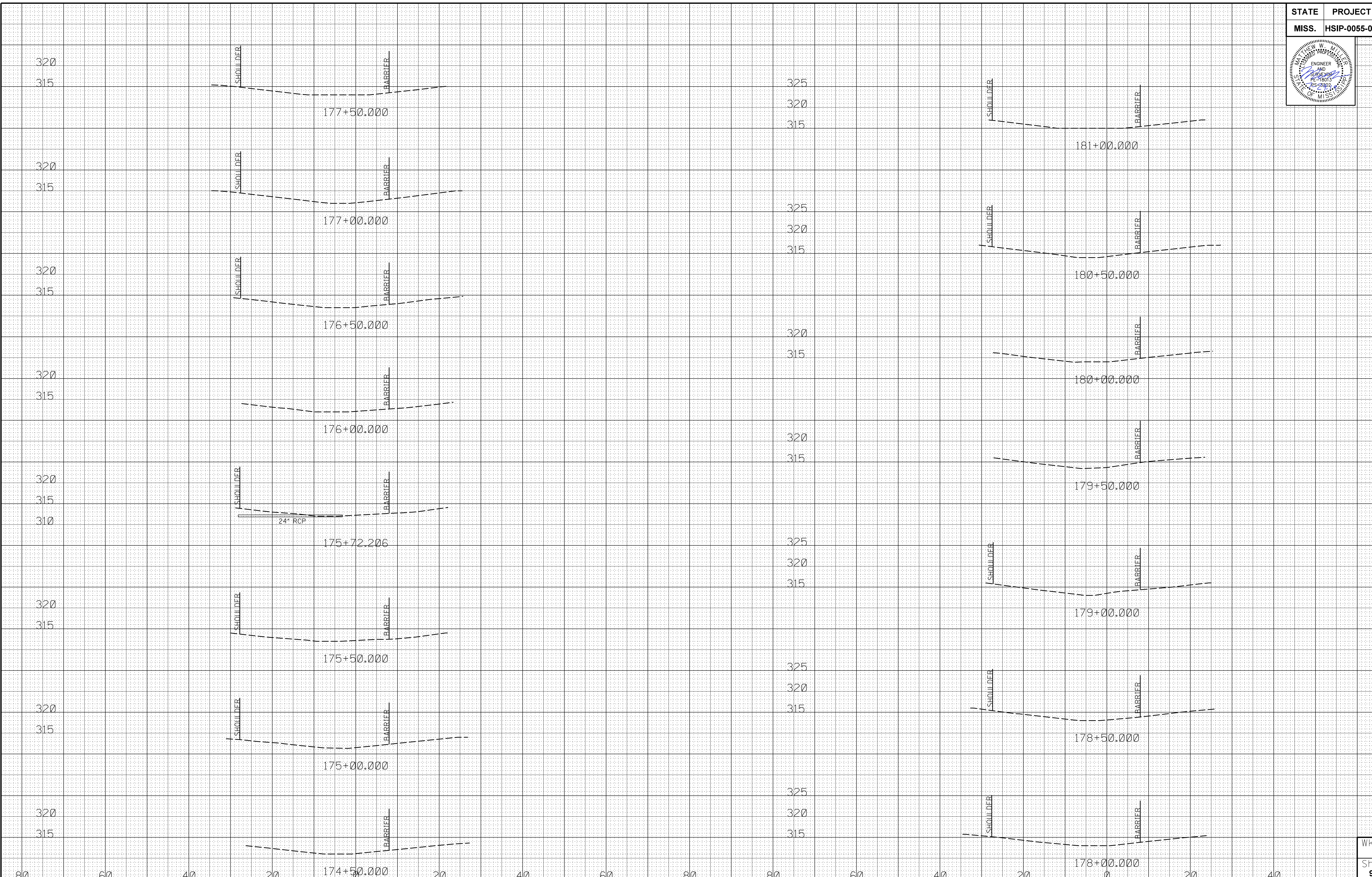

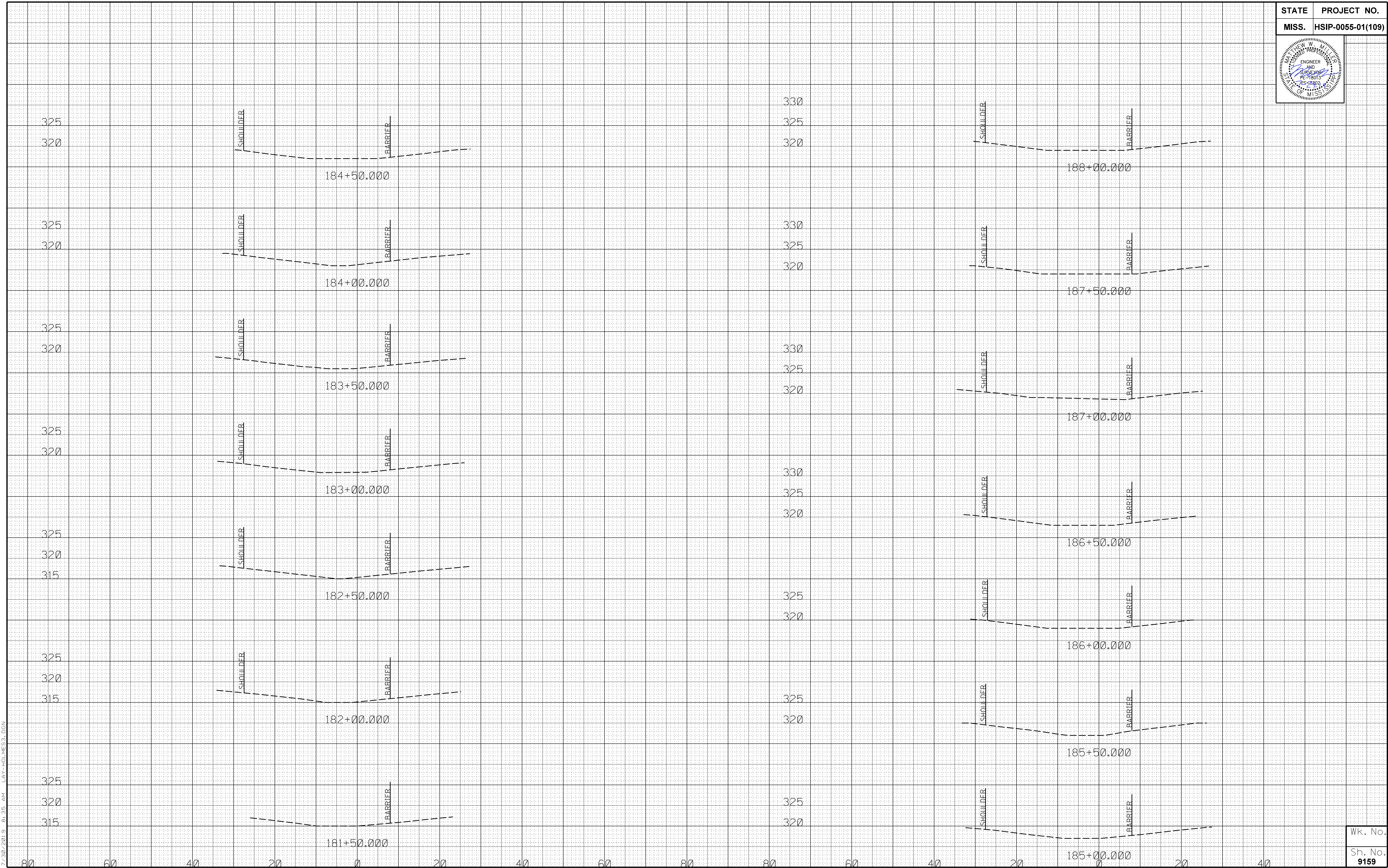
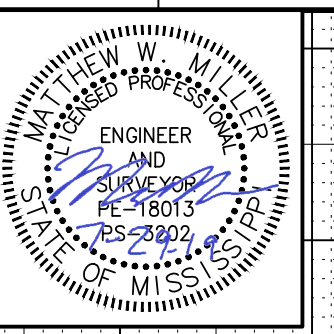

7/30/2019 8:35 AM LAY-HOLMES3.DGN

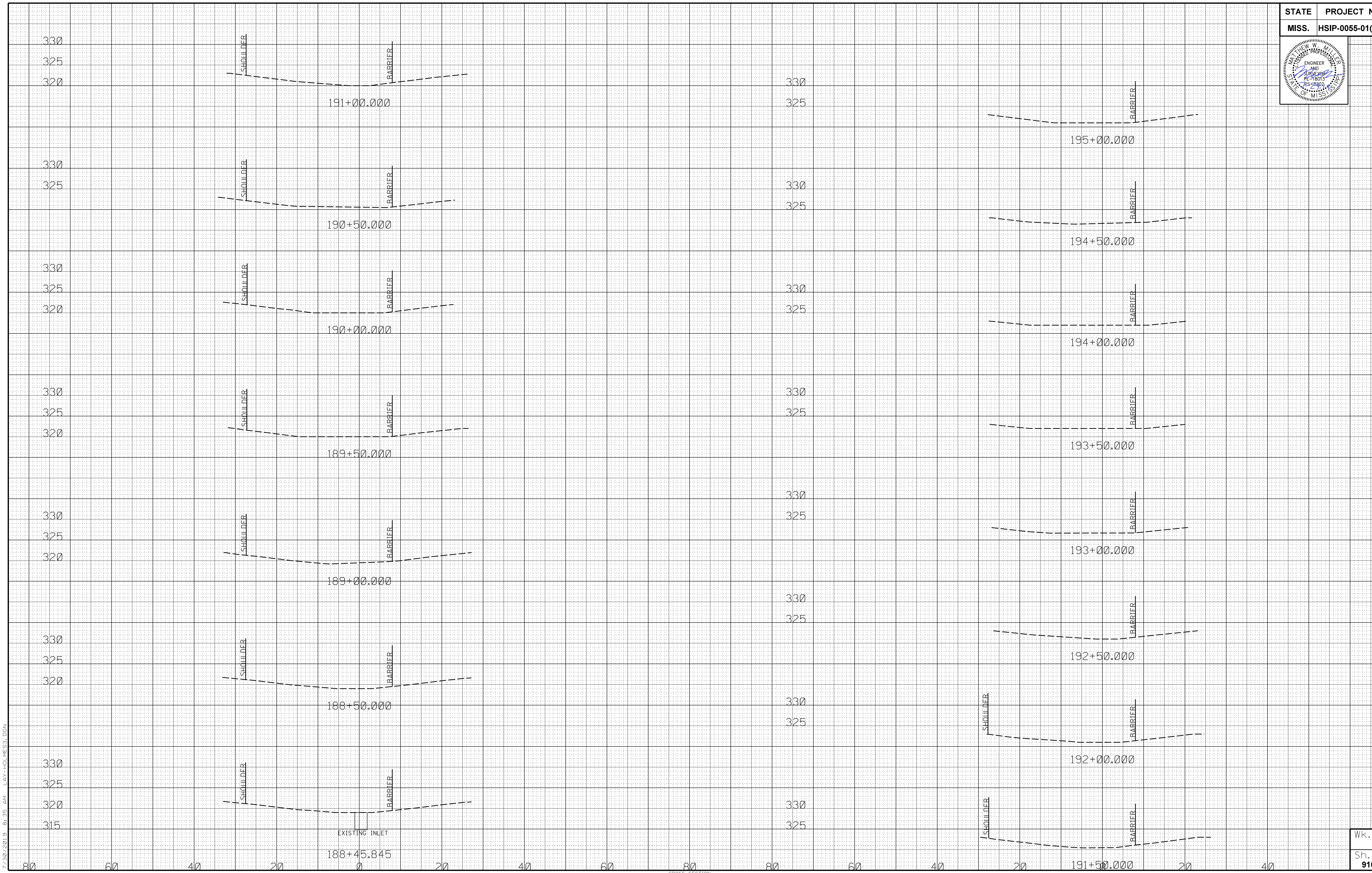
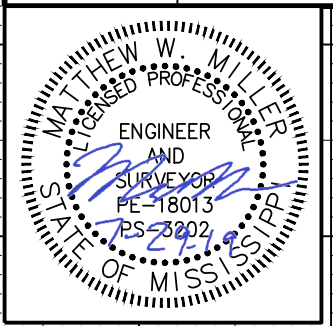

7/30/2019 8:35 AM LAY-HOLMES3.DGN

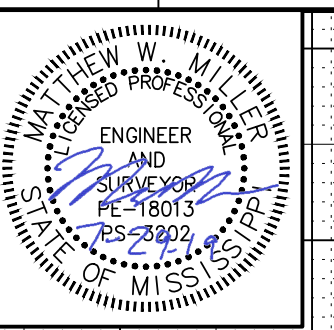

330

325

320



325

320

315

310

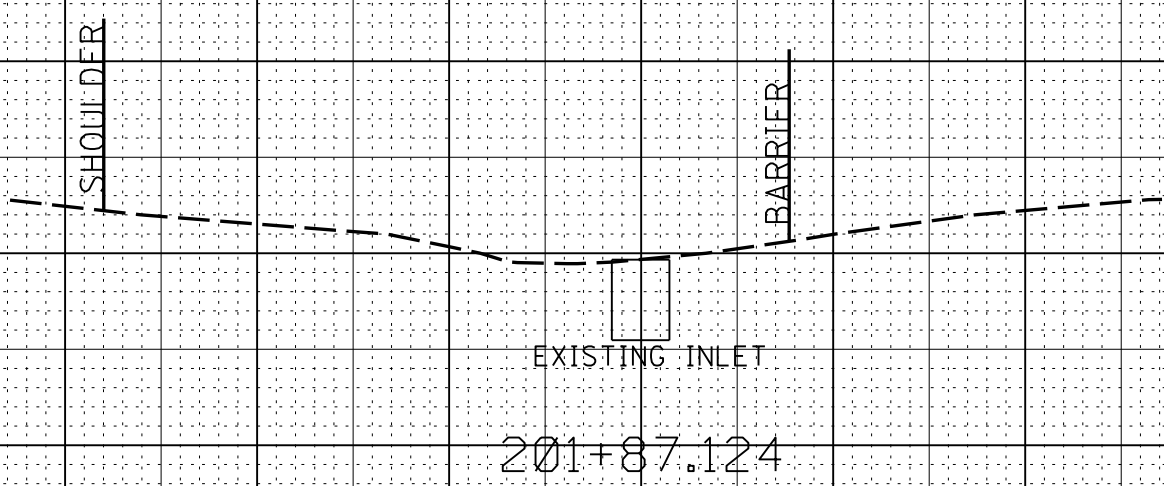

330

325

320



325

320

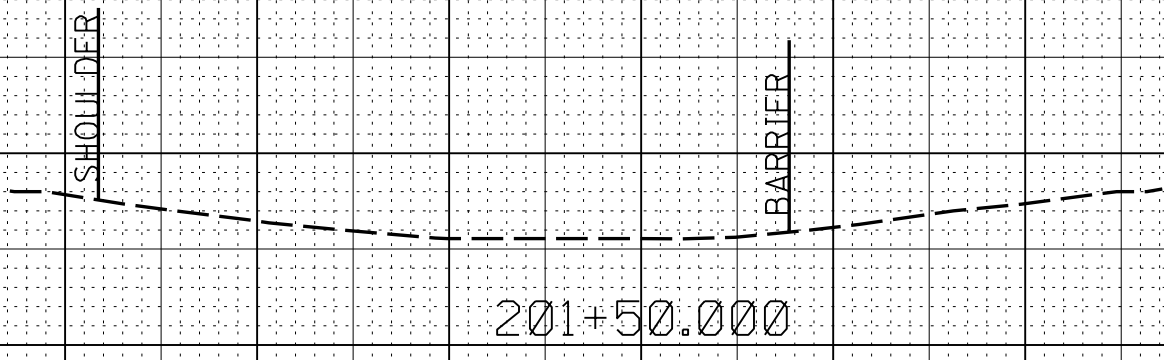

330

325

320

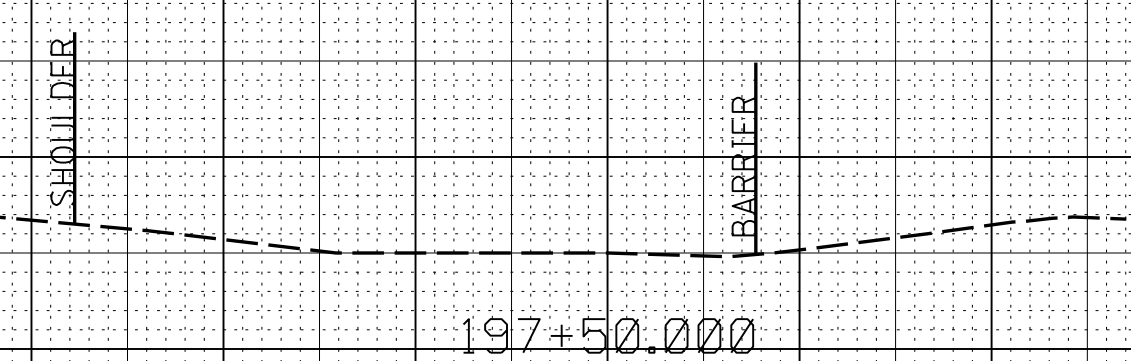

325

320

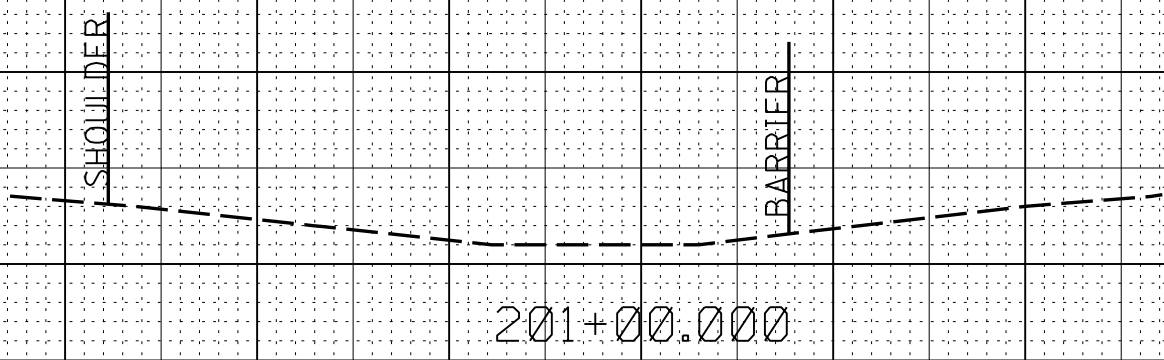

330

325

320

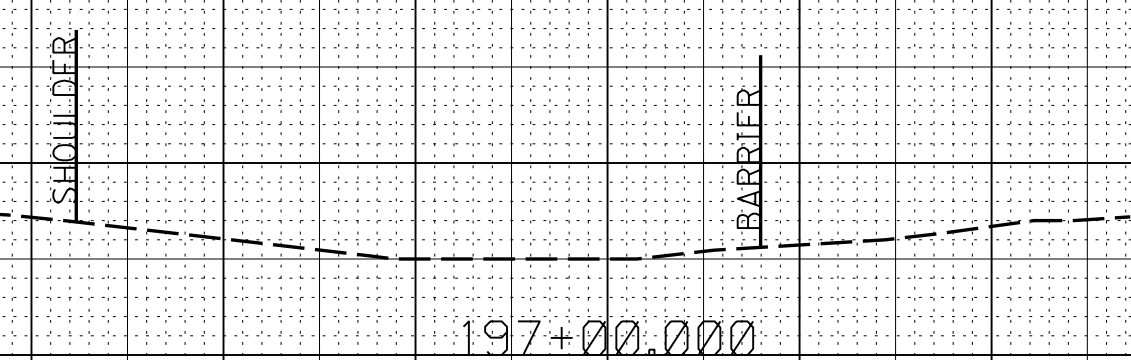

325

320

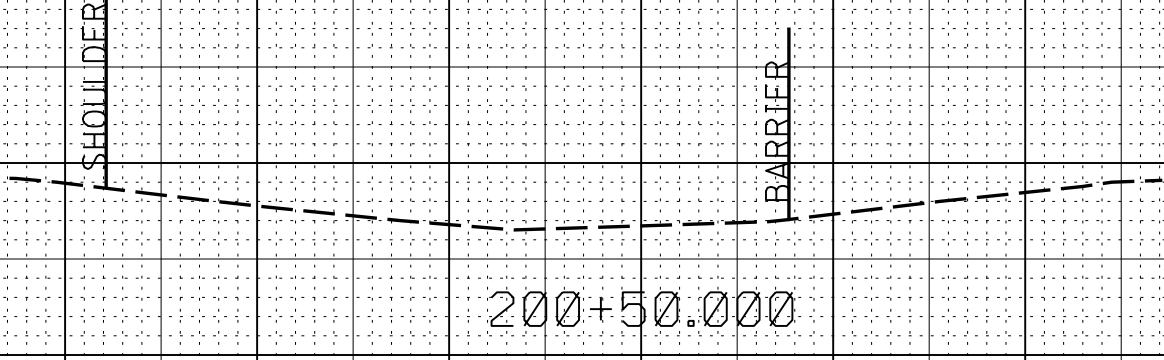

330

325

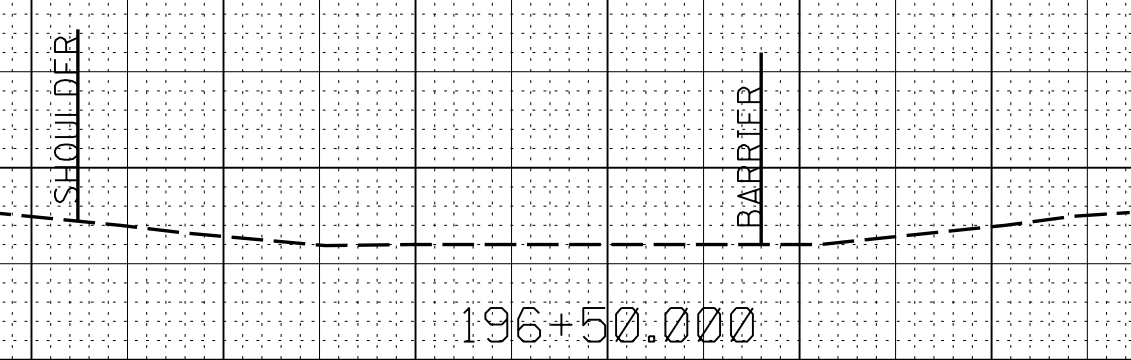

325

320

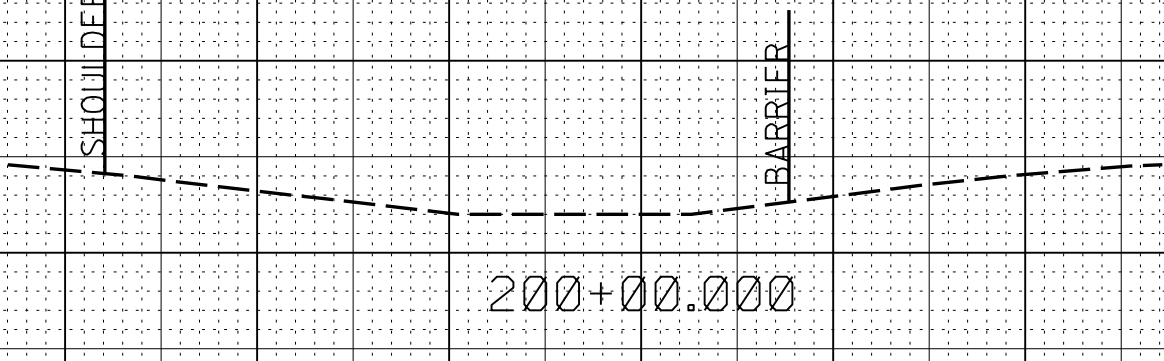

330

325

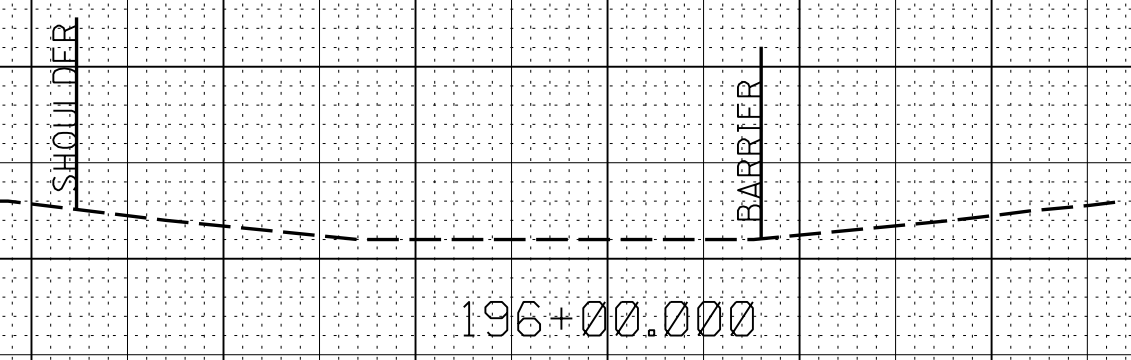

325

320

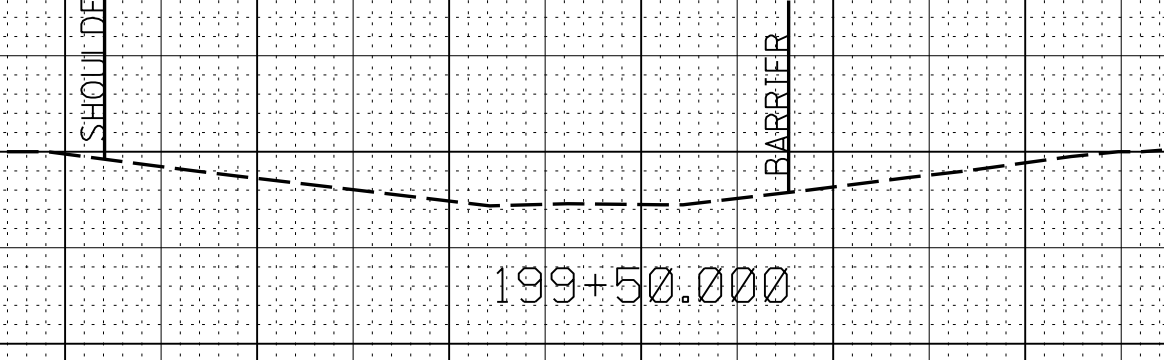

330

325

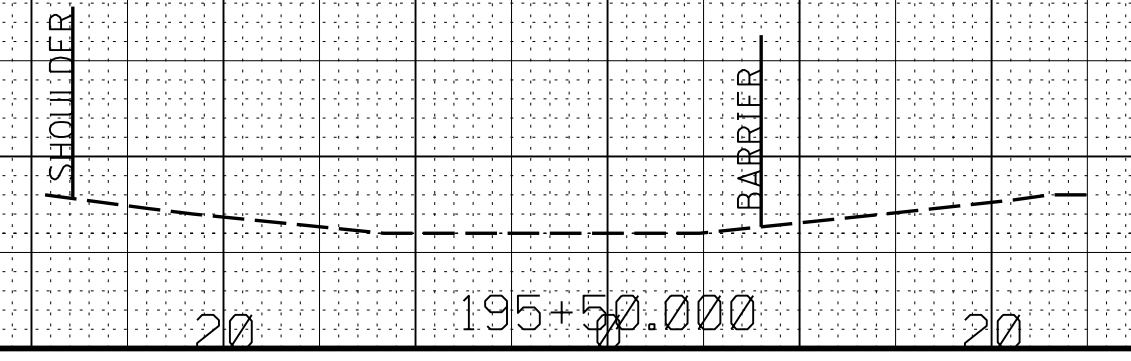

330

325

320

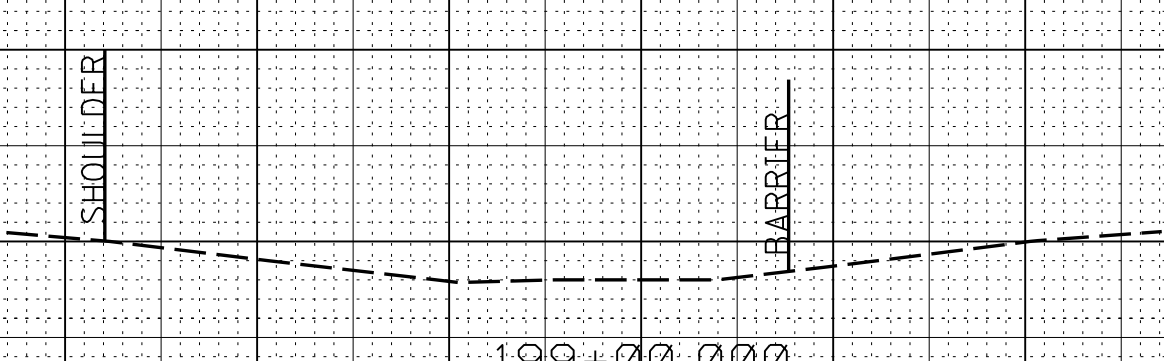

7/30/2019 8:35 AM LAT-HOLMES3.DGN

80 60 40 20 195+50.000 20 40 60 80 80 60 40 20 199+00.000 20 40

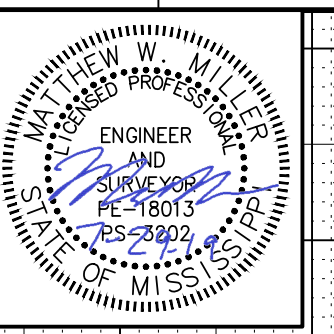

320

315

SHOULDER

BARRIER

205+00.000

320

315

310

SHOULDER

BARRIER

207+50.000

320

315

SHOULDER

BARRIER

204+50.000

320

315

310

SHOULDER

BARRIER

207+22.704

325

320

315

SHOULDER

BARRIER

204+00.000

320

315

310

SHOULDER

BARRIER

207+21.702

325

320

315

SHOULDER

BARRIER

203+50.000

320

315

310

SHOULDER

BARRIER

207+00.000

325

320

315

SHOULDER

BARRIER

203+00.000

320

315

310

SHOULDER

BARRIER

206+50.000

325

320

315

SHOULDER

BARRIER

202+50.000

320

315

310

SHOULDER

BARRIER

206+00.000

325

320

SHOULDER

BARRIER

202+00.000

320

315

310

SHOULDER

BARRIER

205+50.000

3" PVC

3" PVC

7/30/2019 8:35 AM LAY-HOLMES3.DGN

80 60 40 20 202+00.000 20 40 60 80 80 60 40 20 205+50.000 20 40

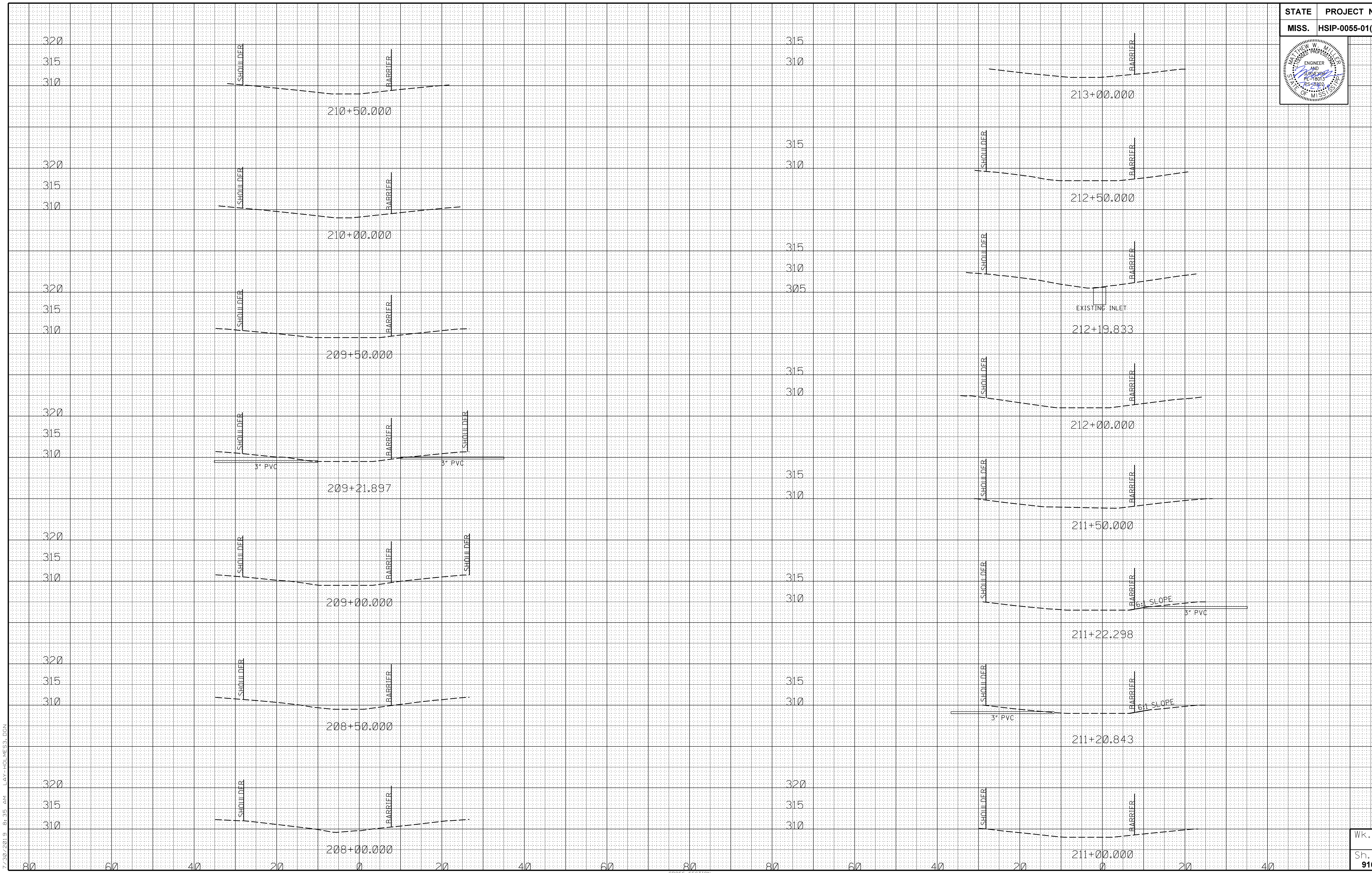
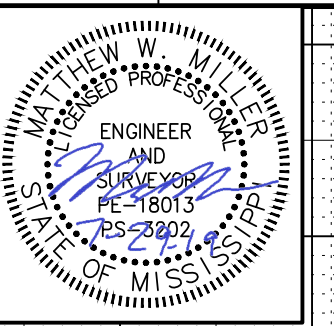

7/30/2019 8:35 AM LAY-HOLMES3.DGN

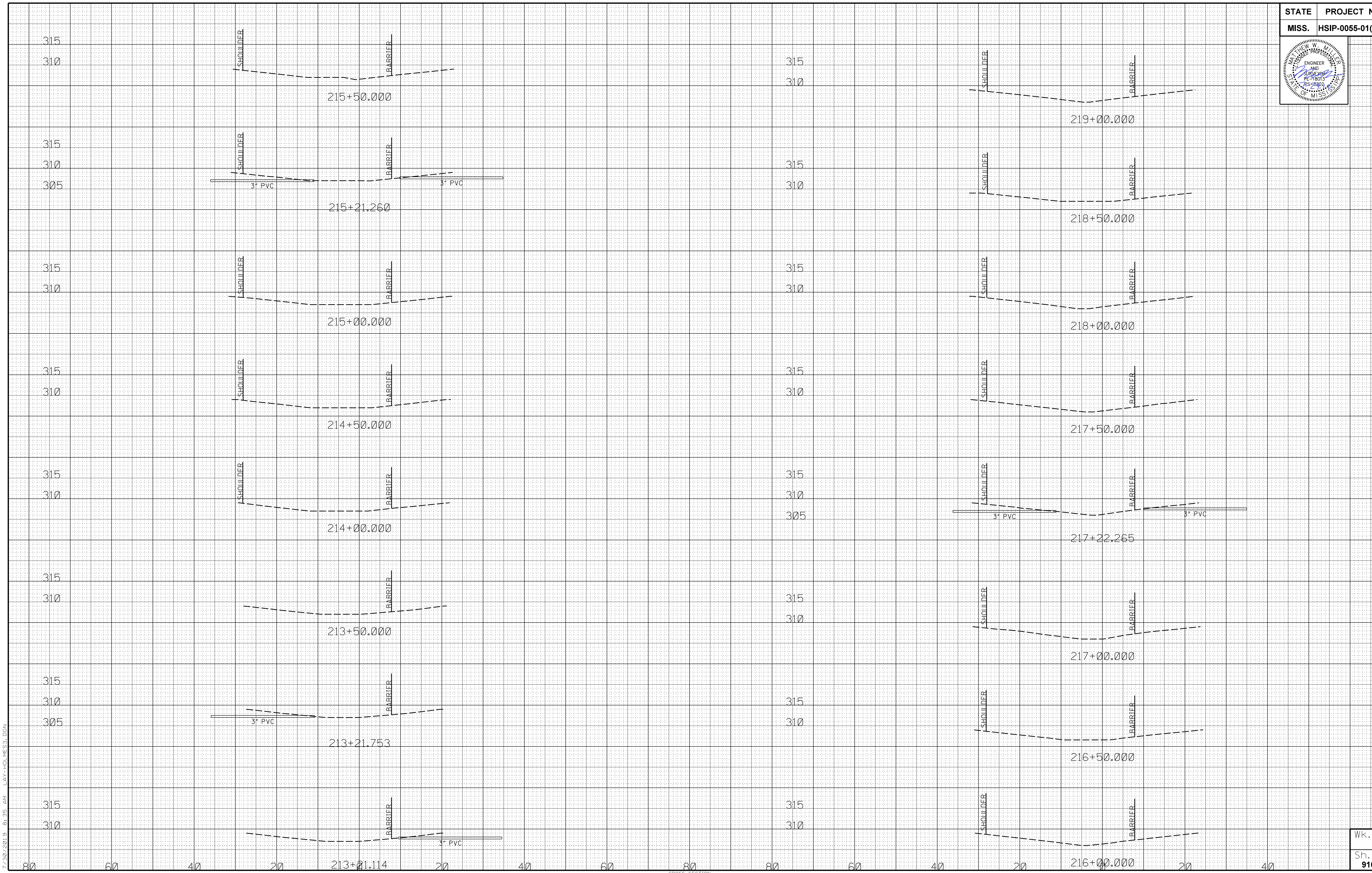
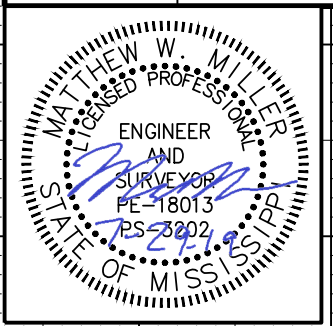

7/30/2019 8:35 AM LAY-HOLMES3.DGN

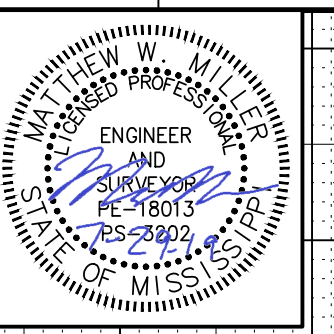

315
310
305
315
310
310
315
310
305
300
315
310
310
315
310
310
315
310
305

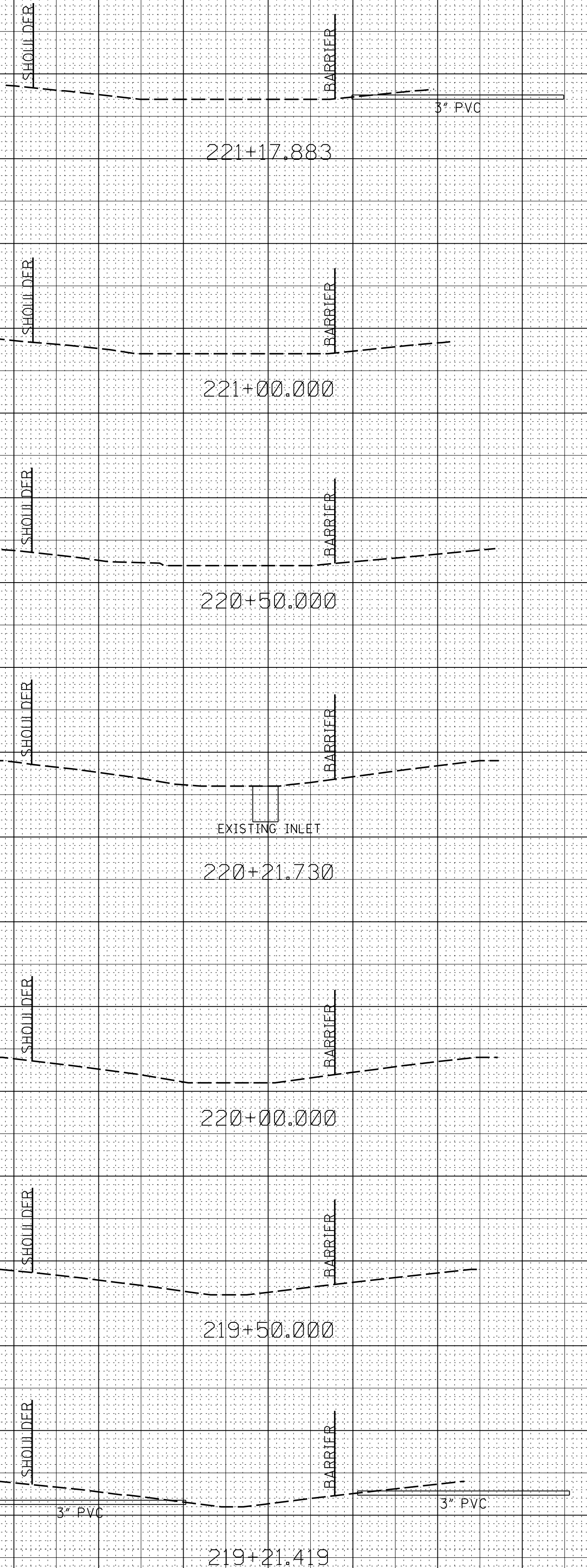

315
310
305
315
310
310
315
310
310
315
310
310
315
310
310
315
310
305

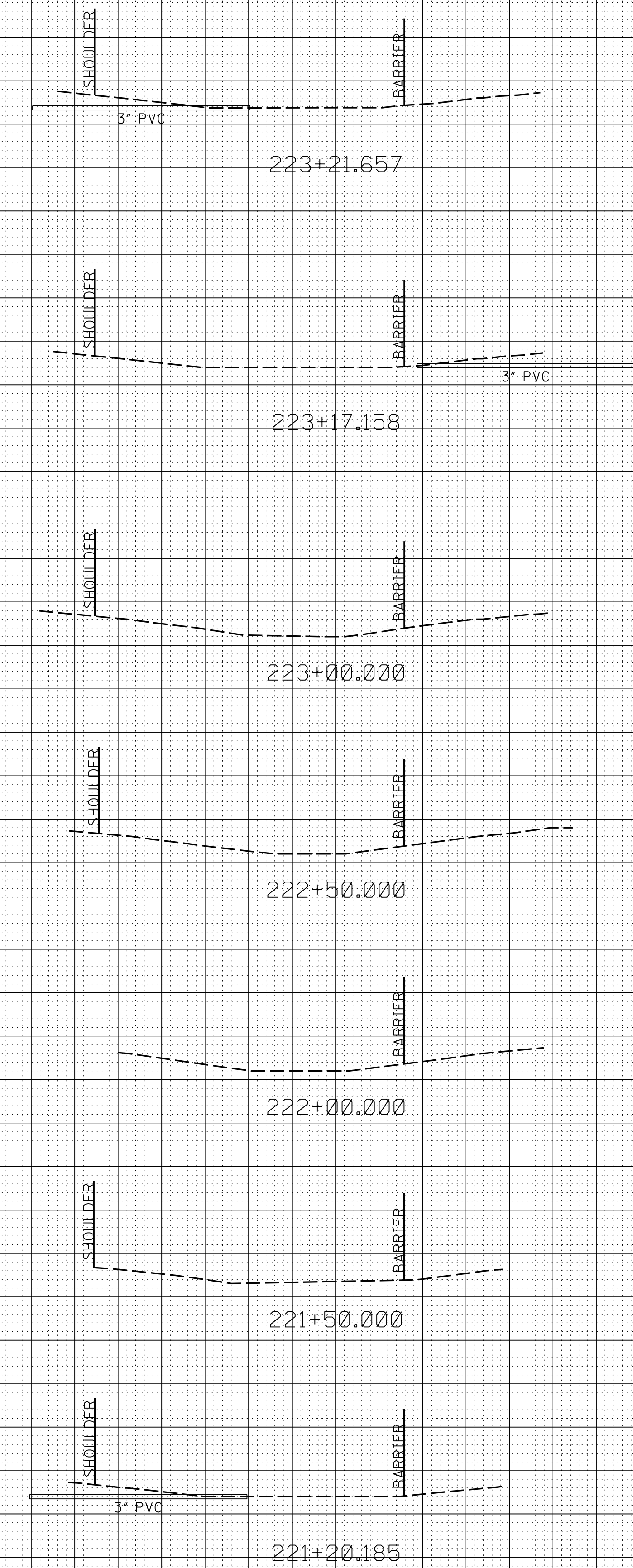

7/30/2019 8:35 AM LAY-HOLMES3.DGN

80 60 40 20 0 20 40 60 80 80 60 40 20 0 20 40

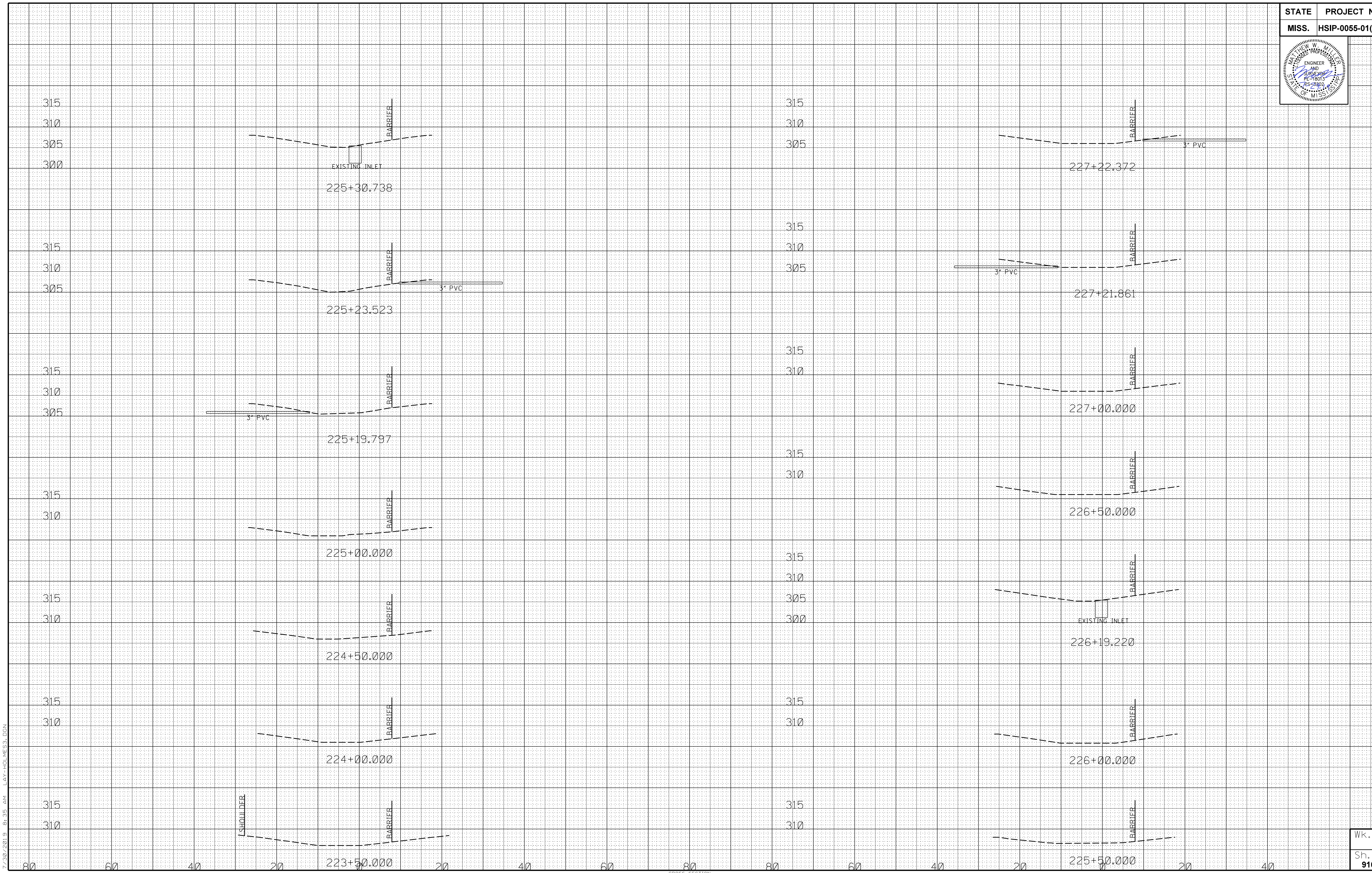
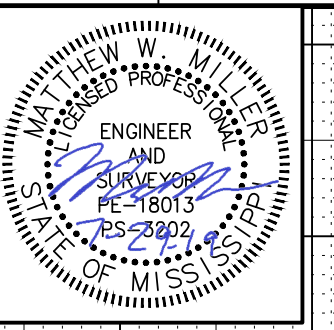

7/30/2019 8:35 AM LAY-HOLMES3.DGN

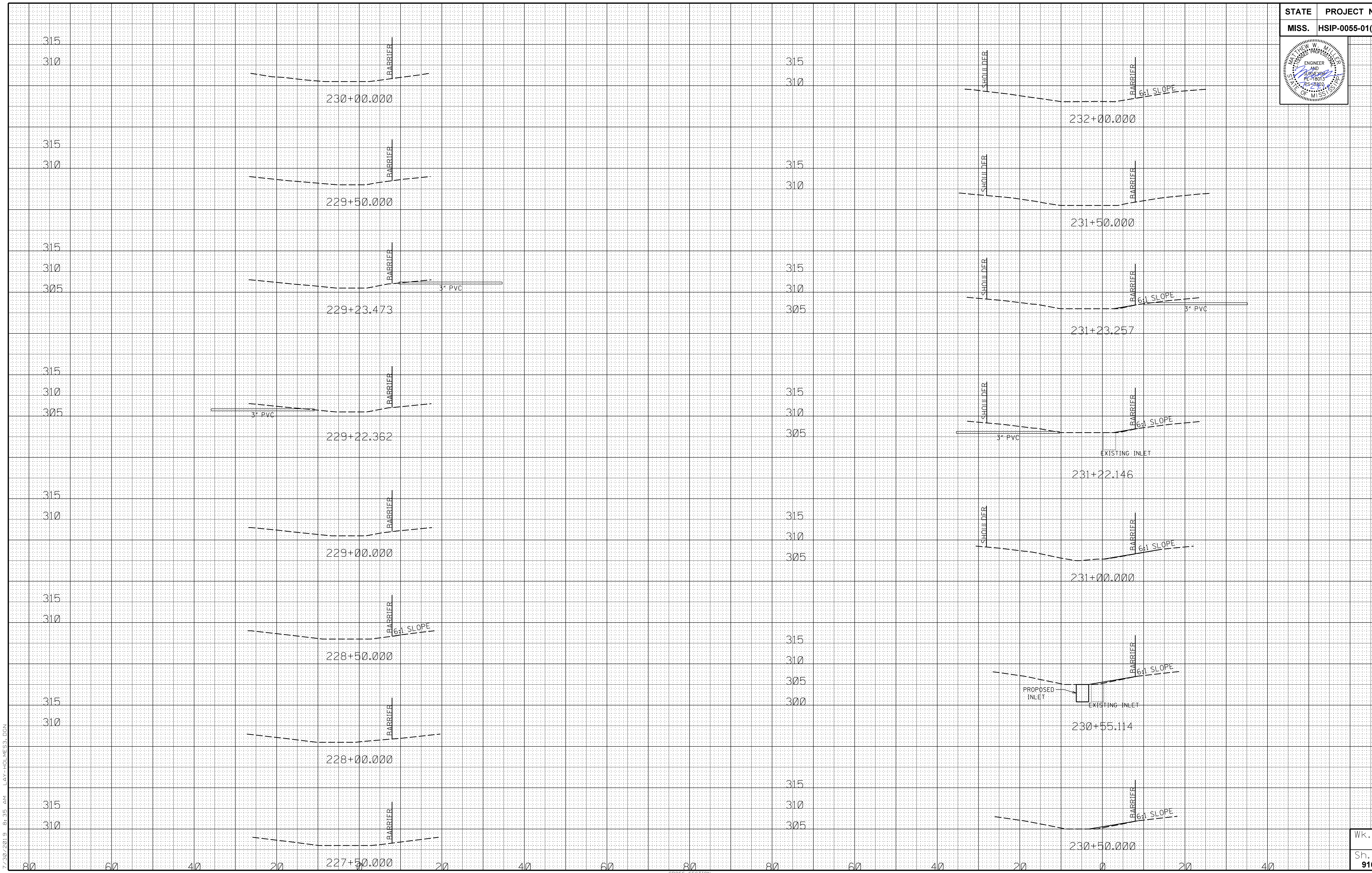
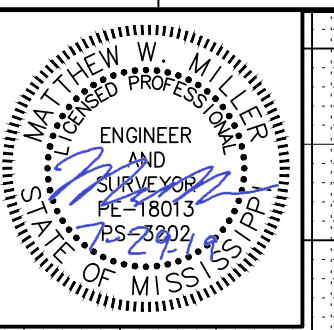

7/30/2019 8:35 AM LAY-HOLMES3.DGN

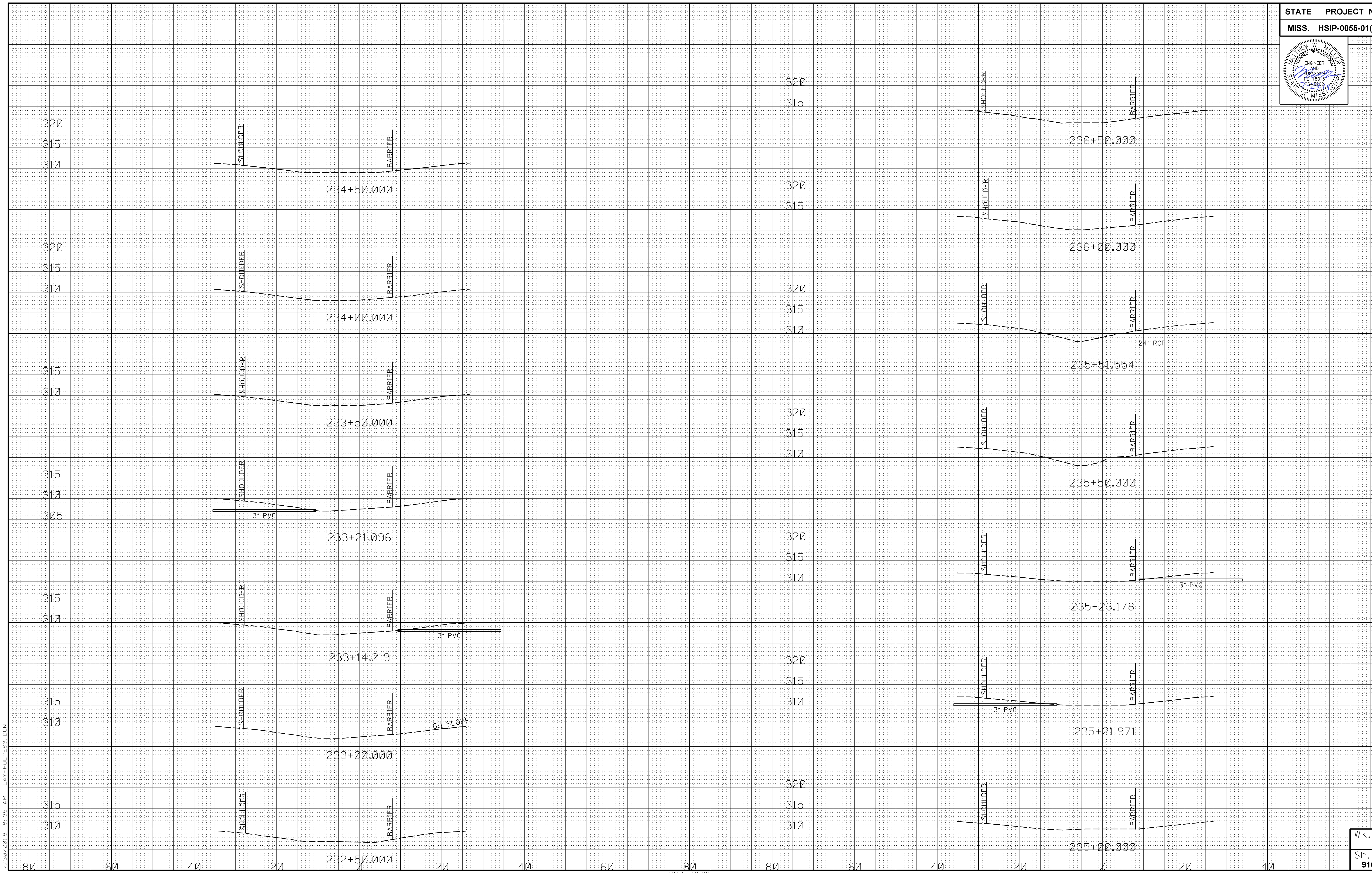
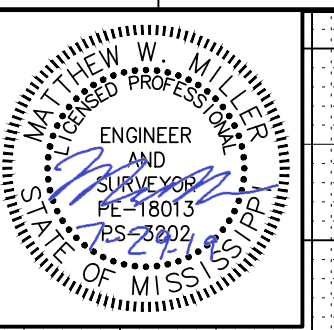

7/20/2019 8:35 AM LAY-HOLMES3.DGN

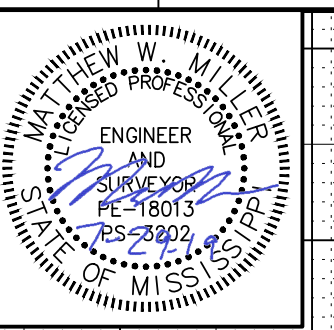

325
320
315
325
320
315
325
320
315
320
315
320
315
320
315
320
315
320
315

330
325
320
330
325
320
330
325
320
330
325
320
330
325
320
330
325
320
330
325
320

239+00.000

242+50.000

238+50.000

242+00.000

238+00.000

241+50.000

237+50.000

241+00.000

237+19.567

240+50.000

237+19.080

240+00.000

237+00.000

239+50.000

SHOULDER

BARRIER

SHOULDER

BARRIER

SHOULDER

BARRIER

SHOULDER

BARRIER

SHOULDER

BARRIER

SHOULDER

BARRIER

SHOULDER

BARRIER

SHOULDER

BARRIER

SHOULDER

BARRIER

SHOULDER

BARRIER

SHOULDER

BARRIER

SHOULDER

SHOULDER

BARRIER

SHOULDER

SHOULDER

BARRIER

SHOULDER

BARRIER

6:1 SLOPE

3" PVC

3" PVC

3" PVC

3" PVC

7/20/2019 8:35 AM LAT-HOL.ME3.DGN

Wk. No.

Sh. No. 9169

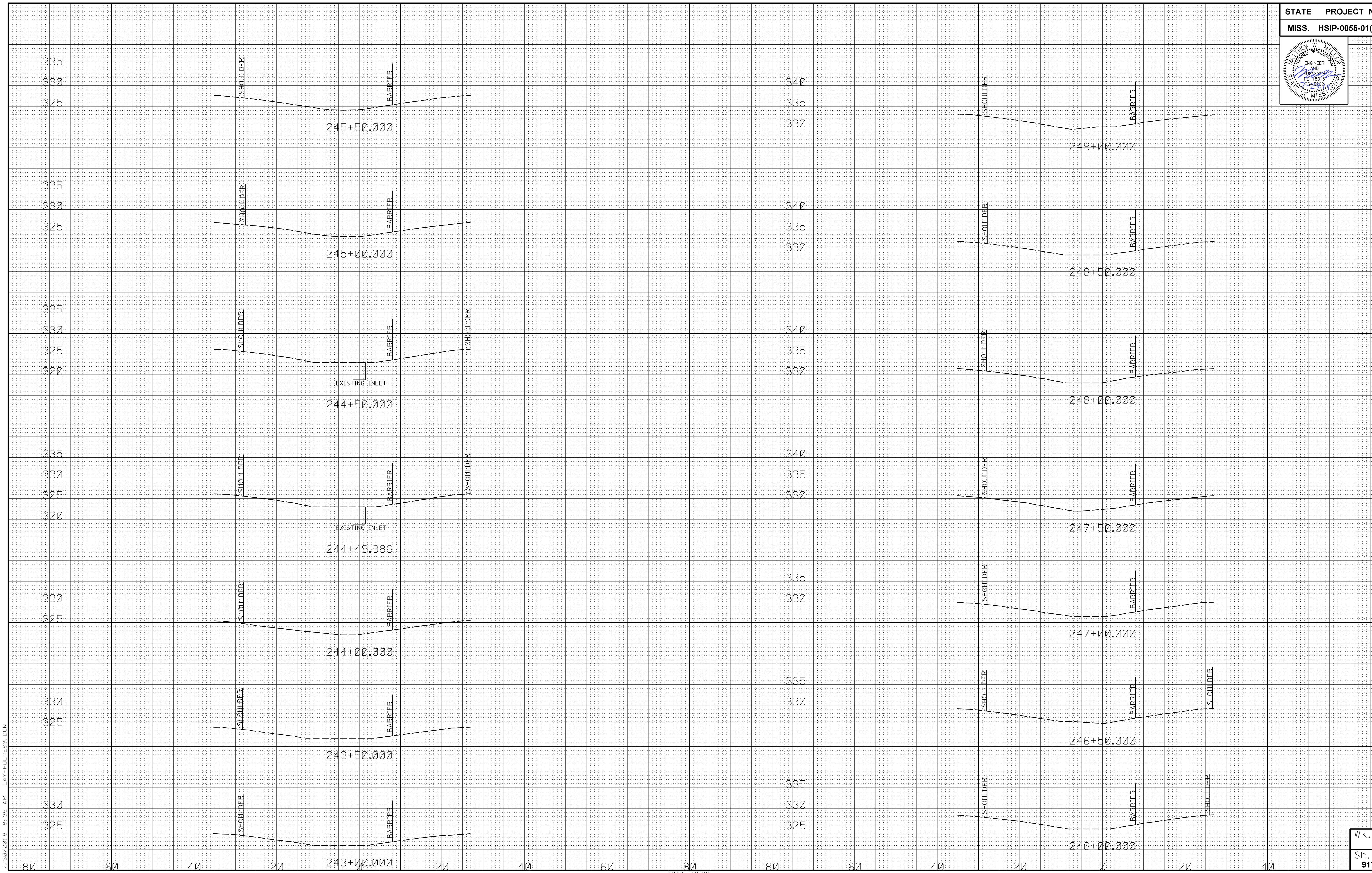
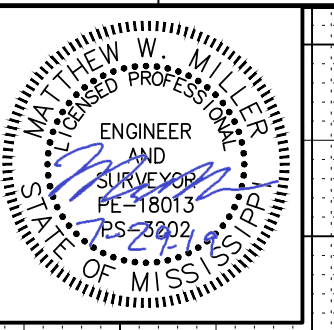

7/30/2019 8:35 AM LAY-HOLMES3.DGN

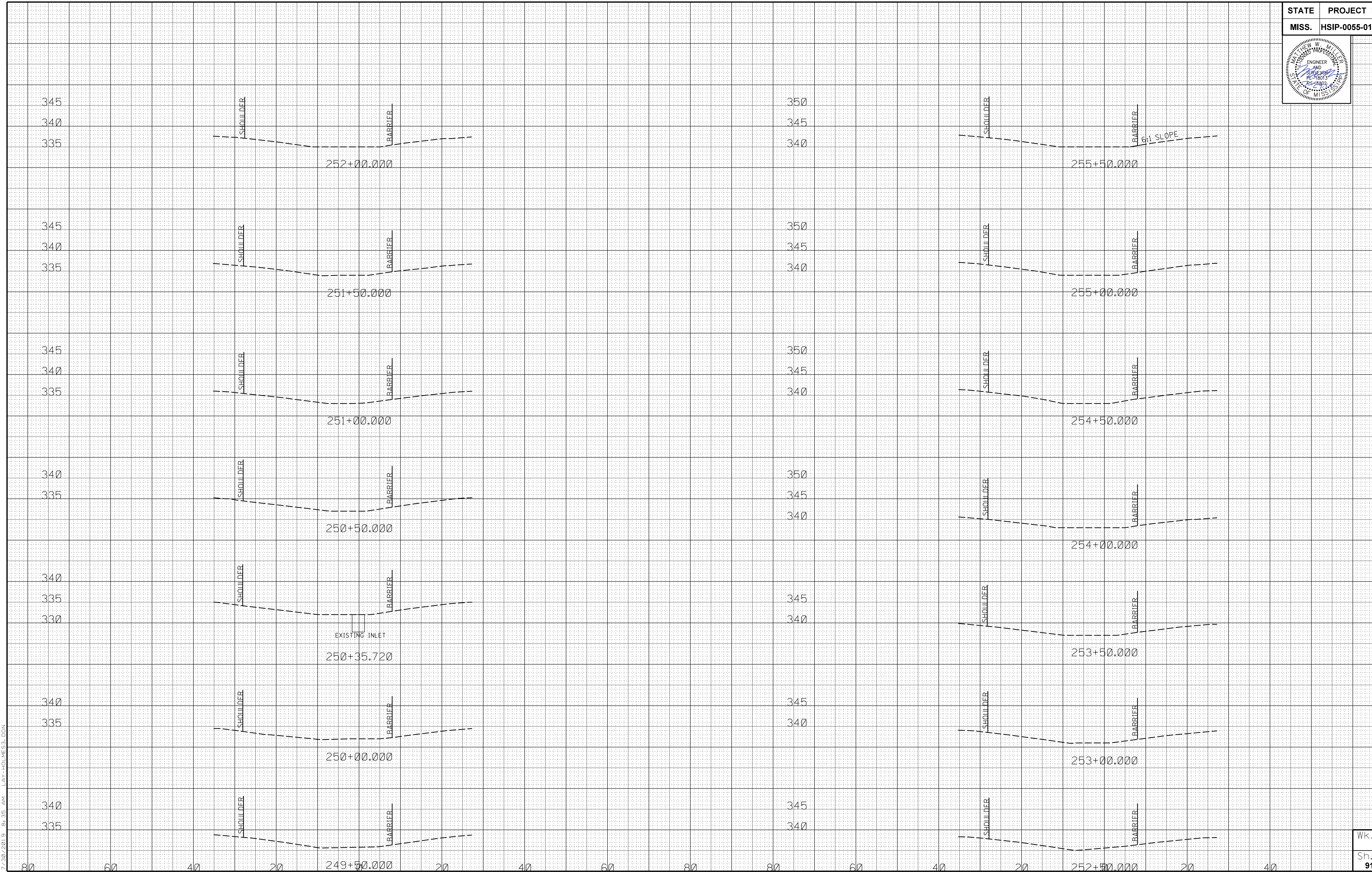
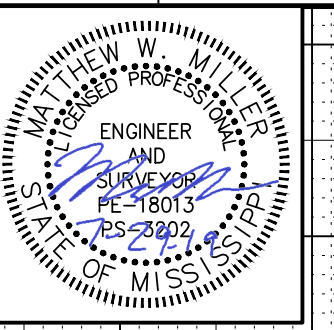

7/30/2019 8:35 AM LAY-HOL.ME3.DGN

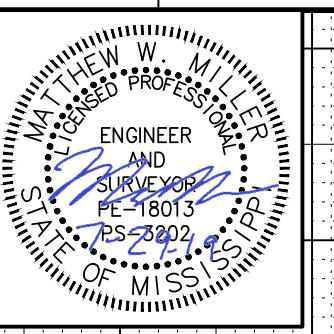

355
350
345

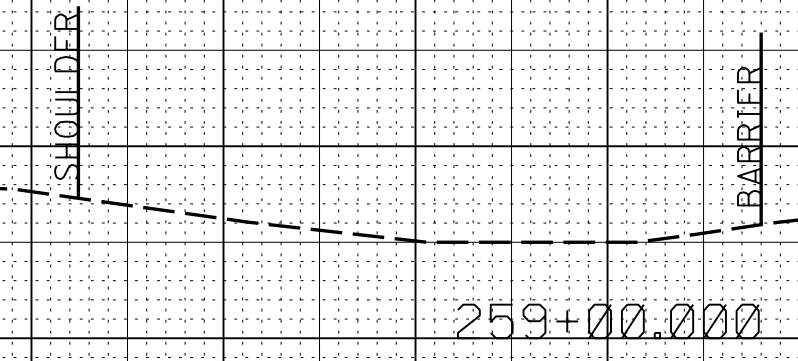

360
355
350

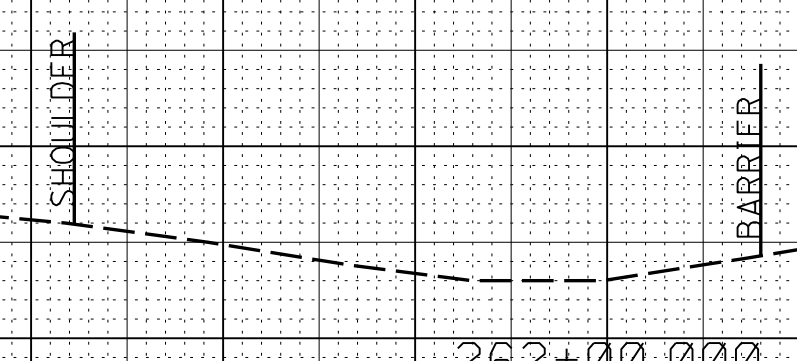

355
350
345

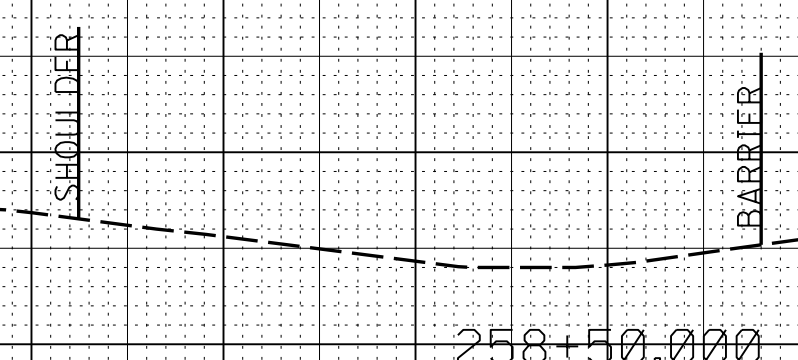

360
355
350

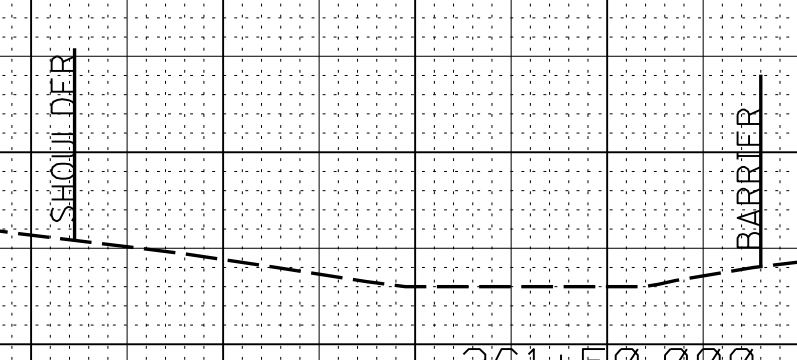

355
350
345



360
355
350

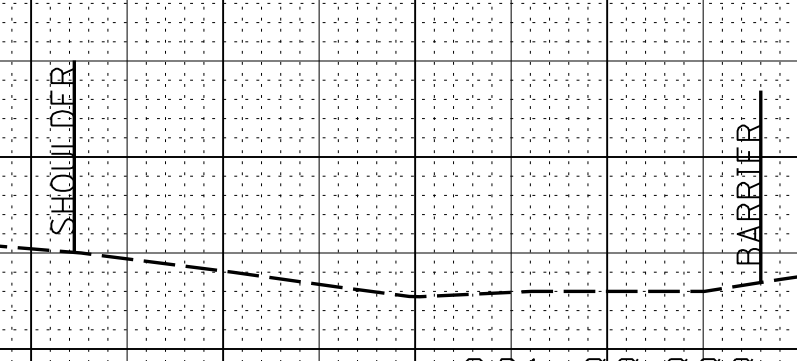

355
350
345

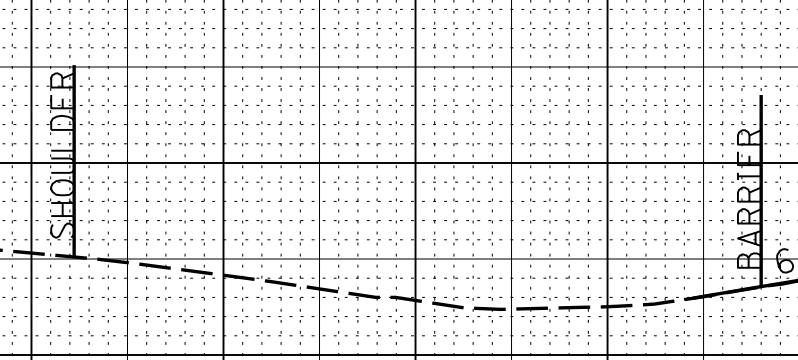

360
355
350

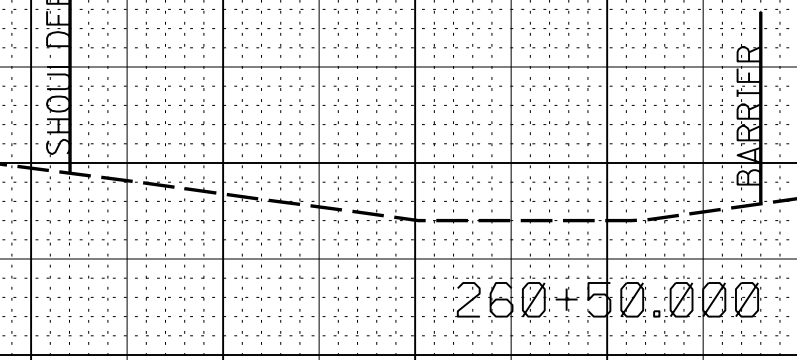

350
345

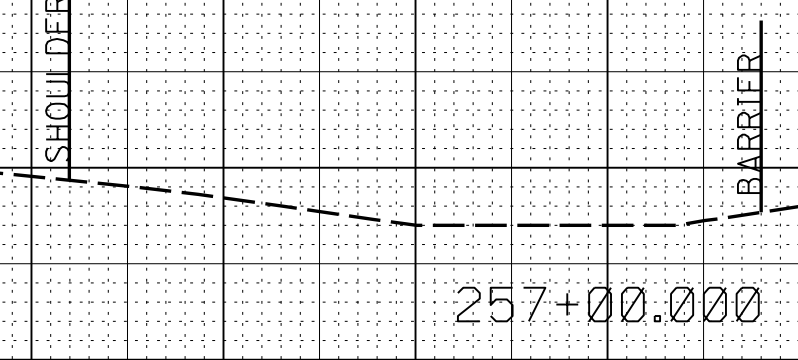

355
350
345

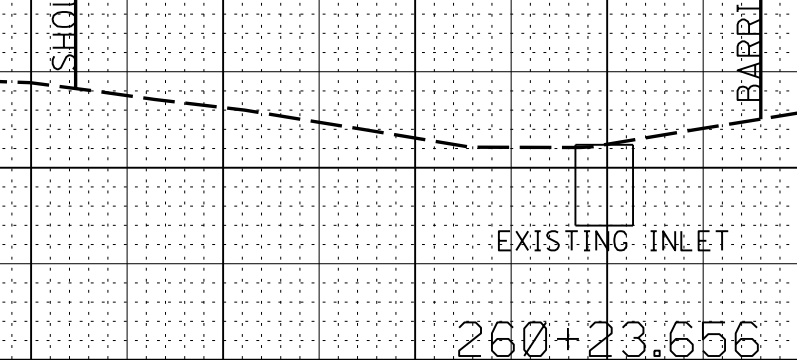

350
345

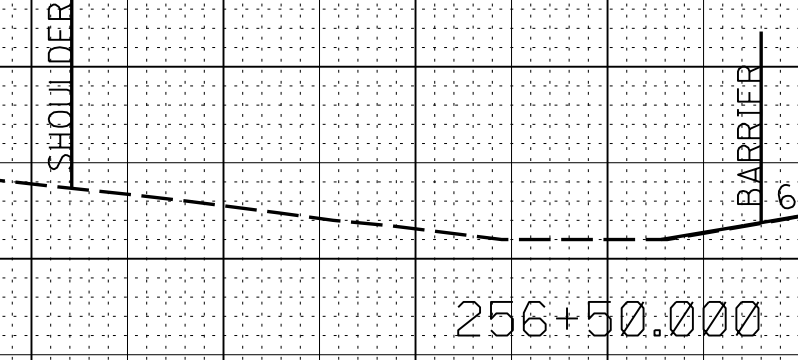

355
350
345

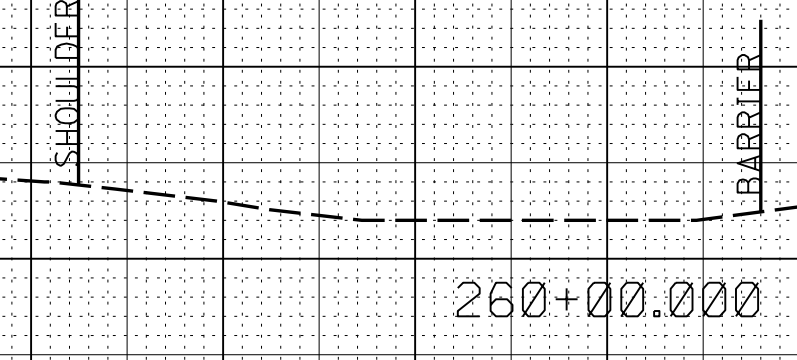

350
345

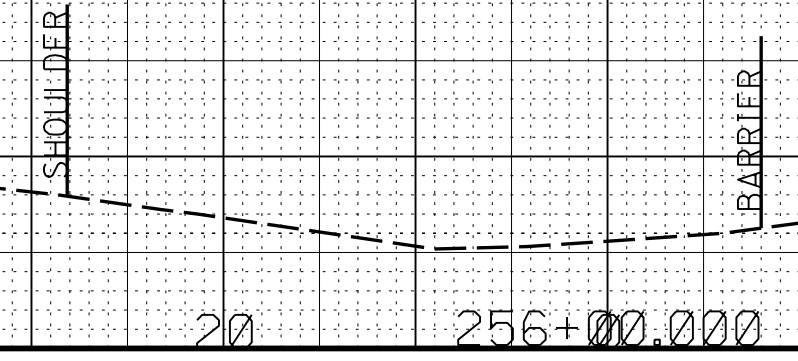

355
350
345

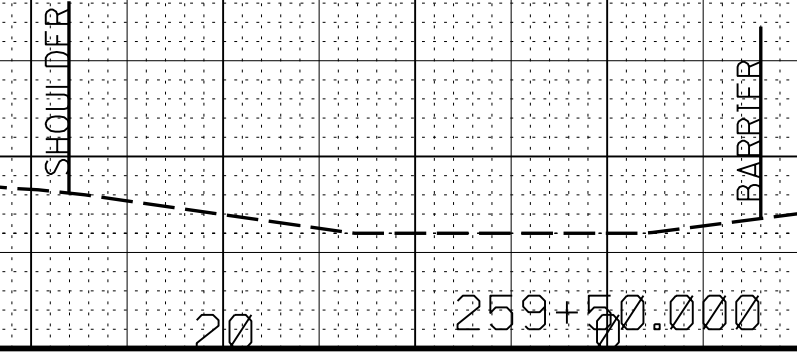

7/30/2019 8:35 AM LAY-HOL.MES3.DGN

80 60 40 20 256+00.000 20 40 60 80 80 60 40 20 259+50.000 20 40

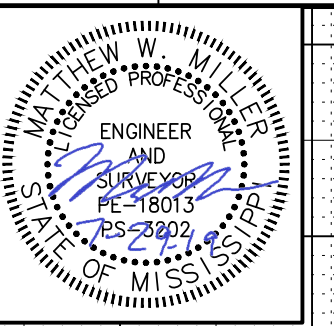

360
355
350
360
355
350
360
355
350
360
355
350
360
355
350
360
355
350
360
355
350
360
355
350

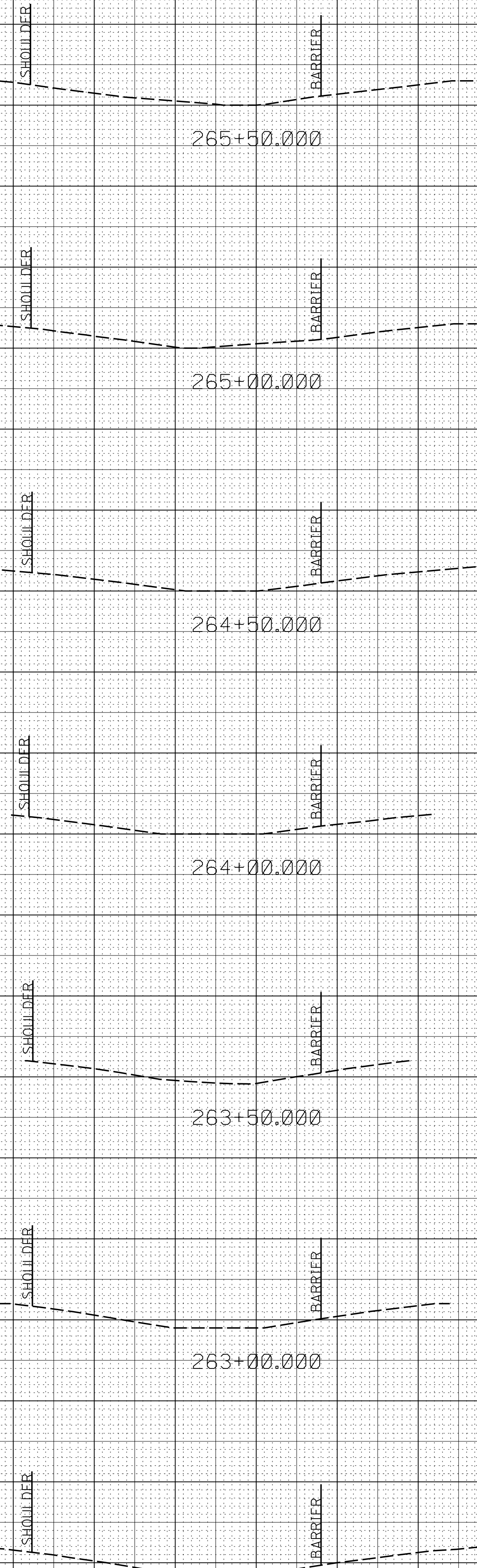

360
355
350
360
355
350
360
355
350
360
355
350
360
355
350
360
355
350

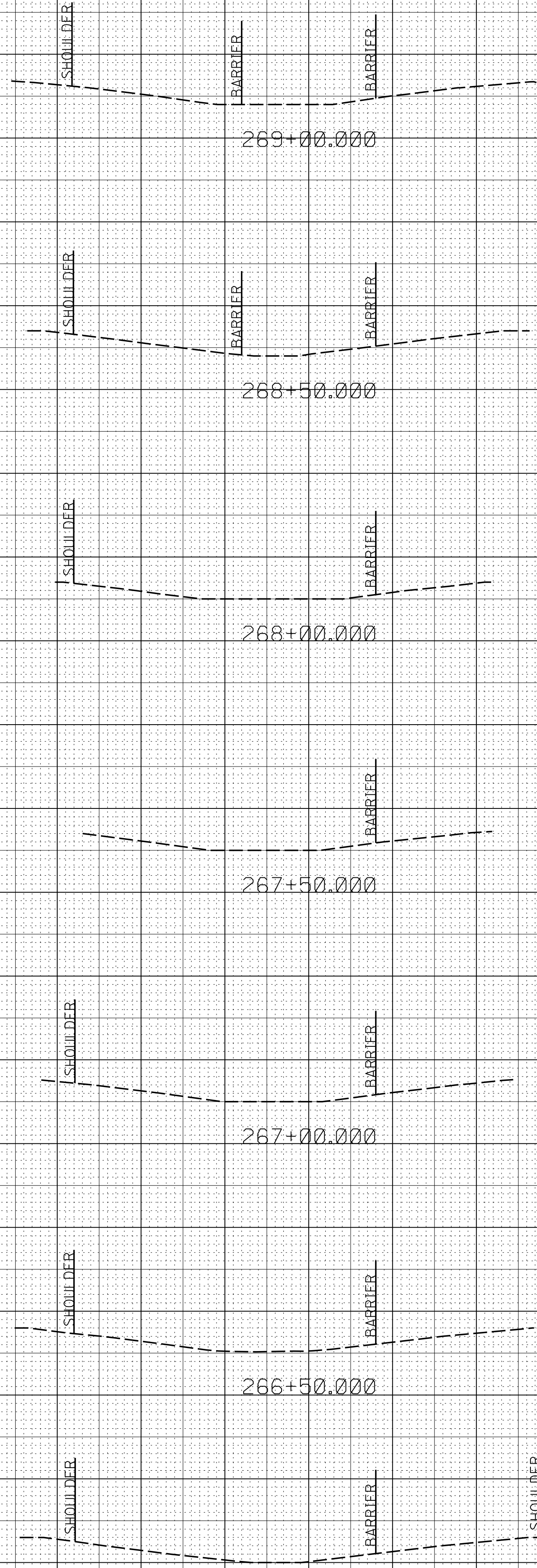

7/30/2019 8:35 AM LAY-HOLMES3.DGN

80 60 40 20 0 20 40 60 80 80 60 40 20 0 20 40

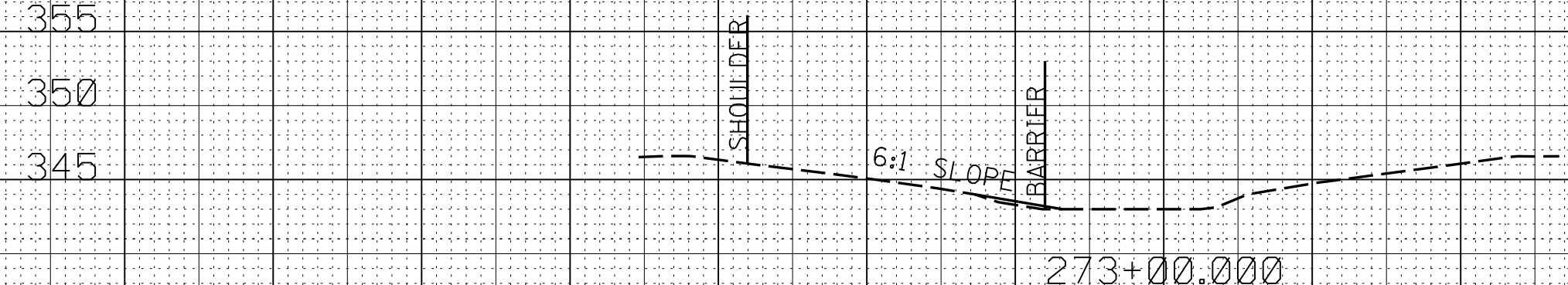
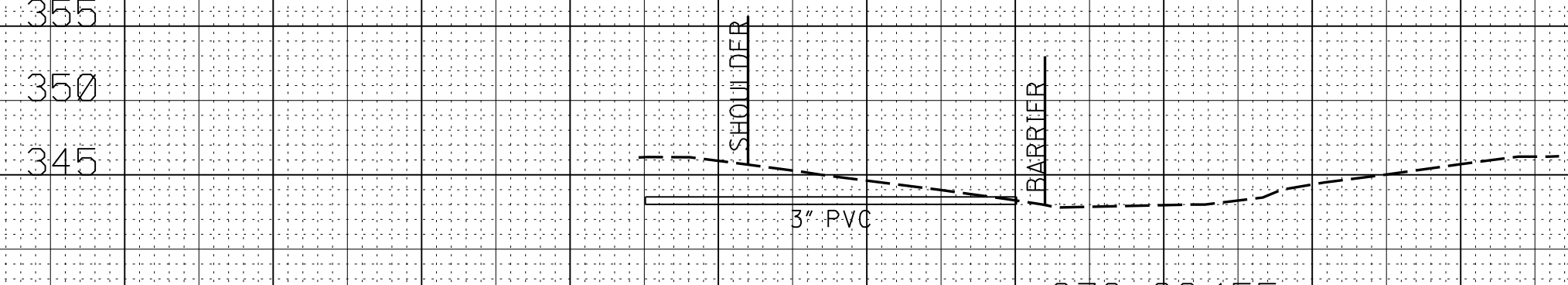
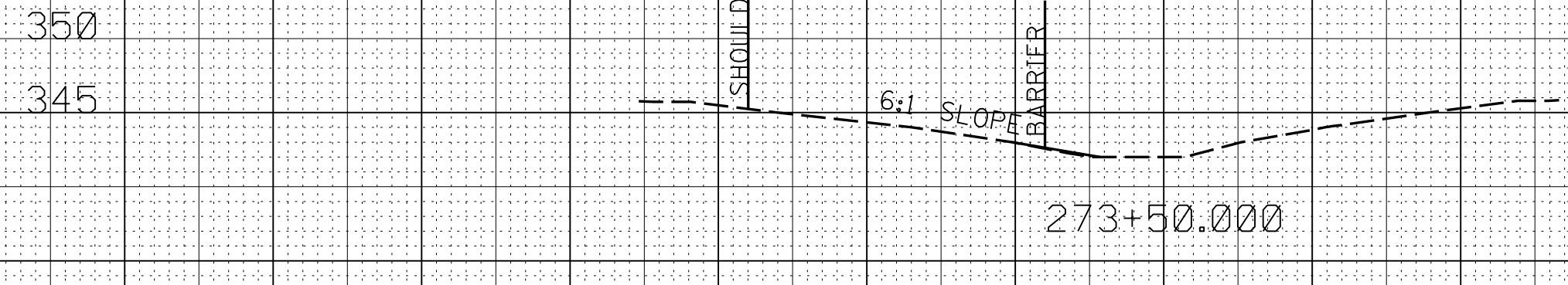
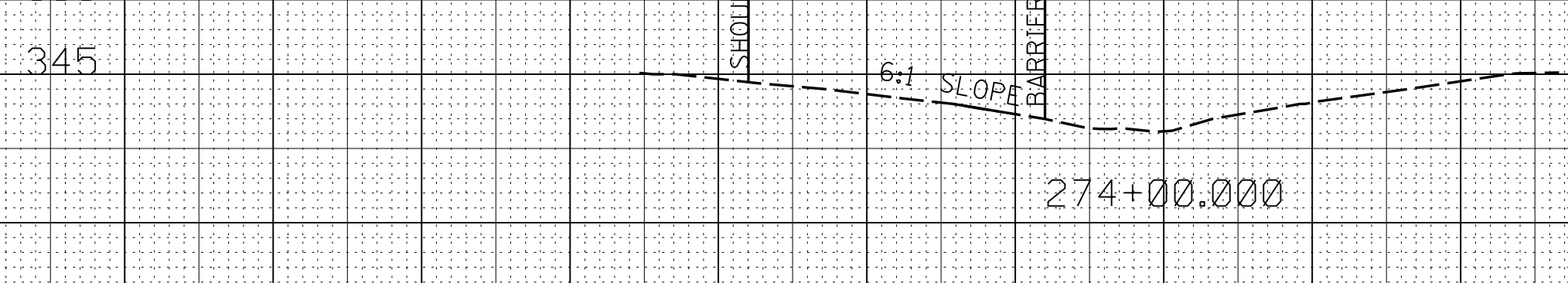
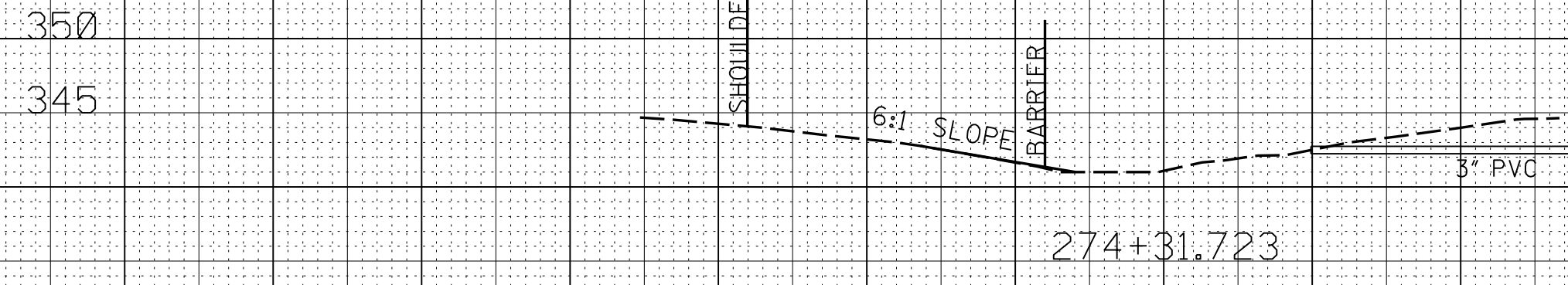
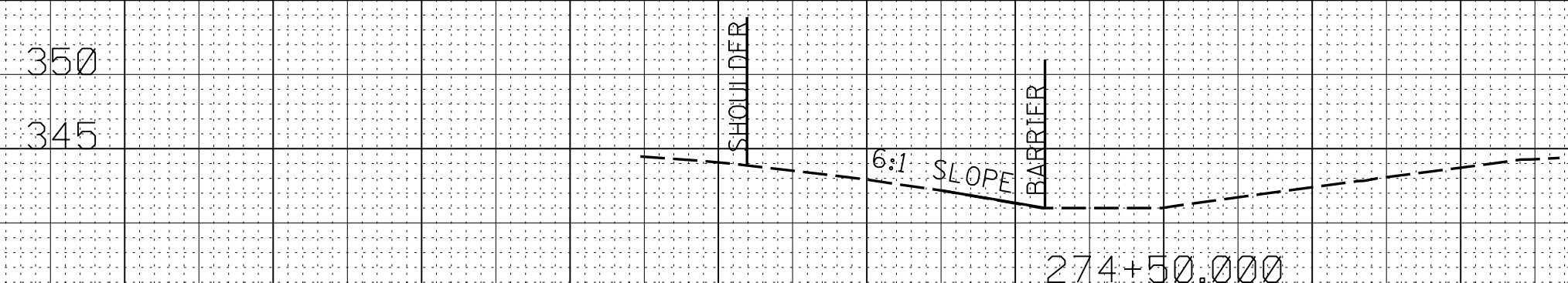
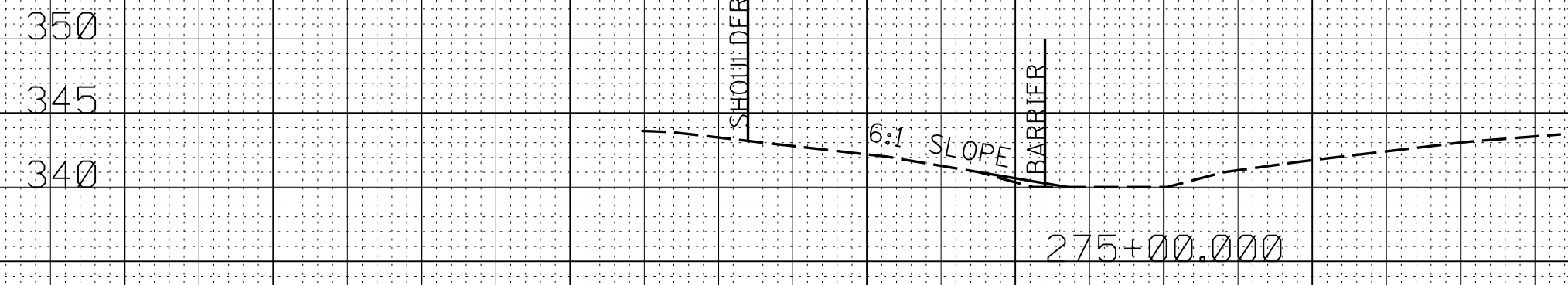
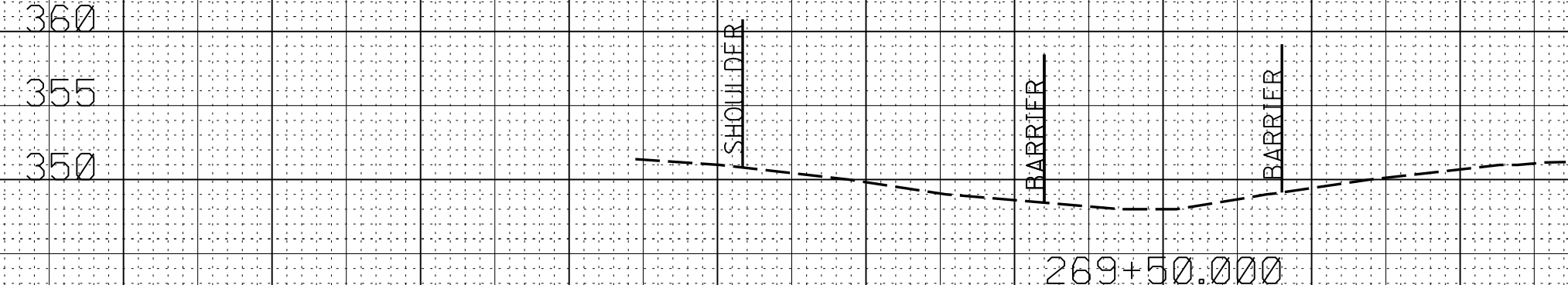
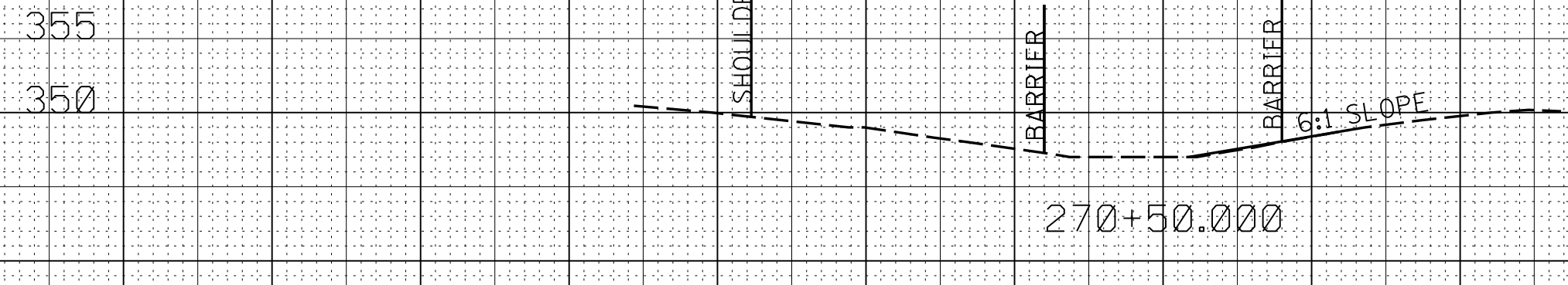
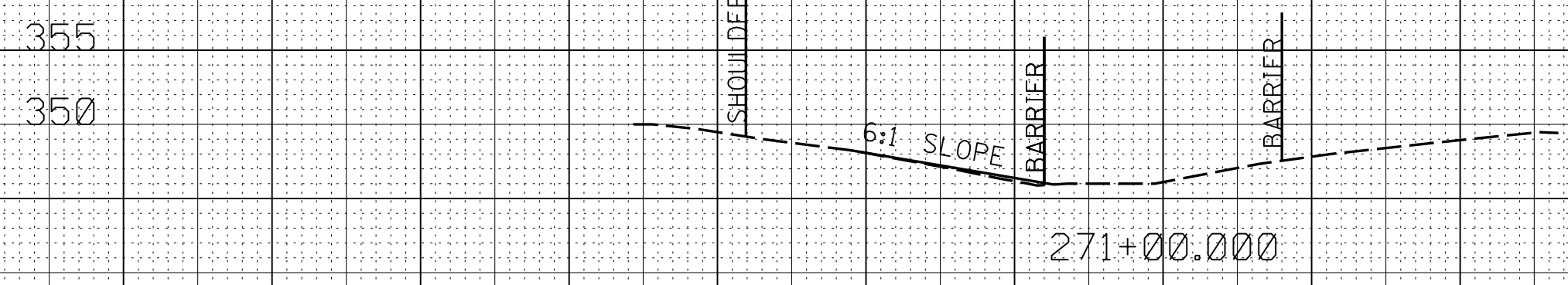
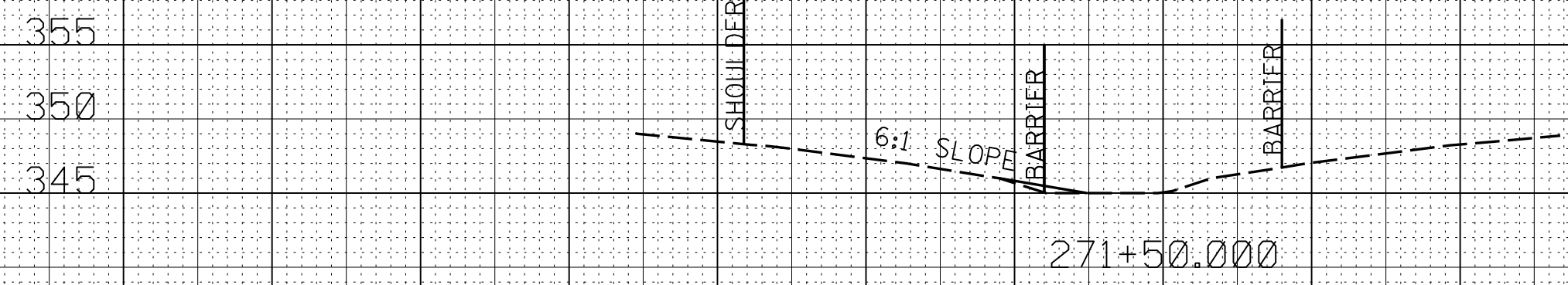
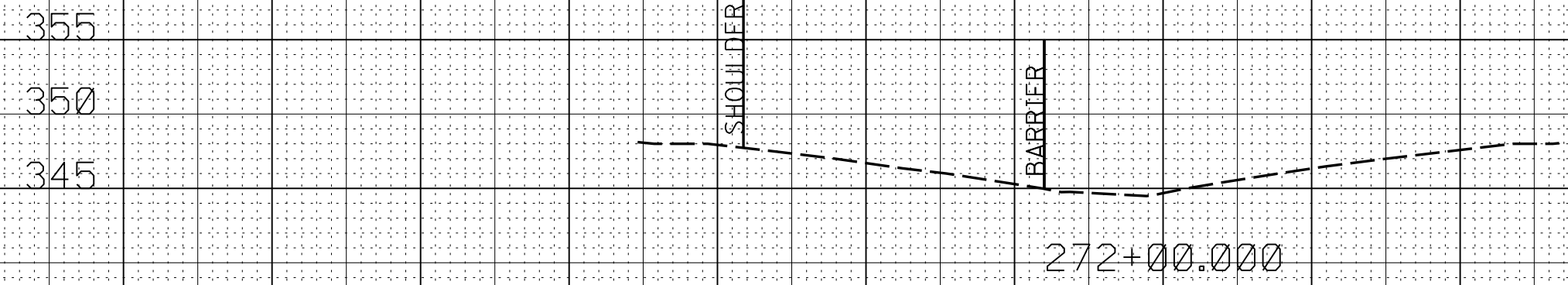
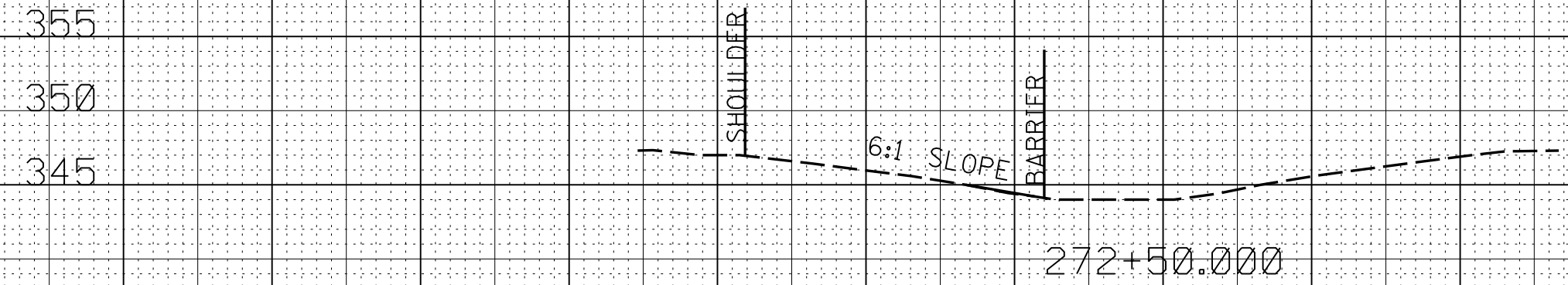
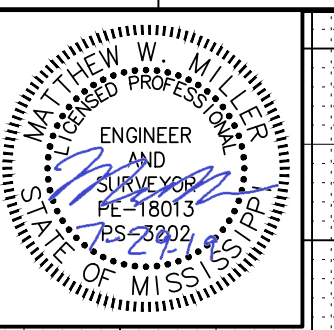

7/30/2019 8:35 AM LAY-HOLMES3.DGN

80 60 40 20 0 20 40 60 80 80 60 40 20 0 20 40

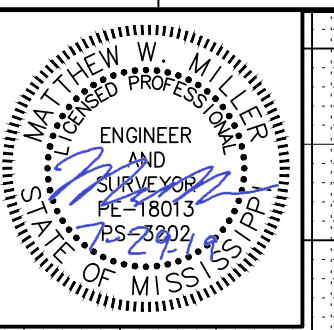

345
340
345
340
350
345
340
350
345
340
350
345
340
350
345
340

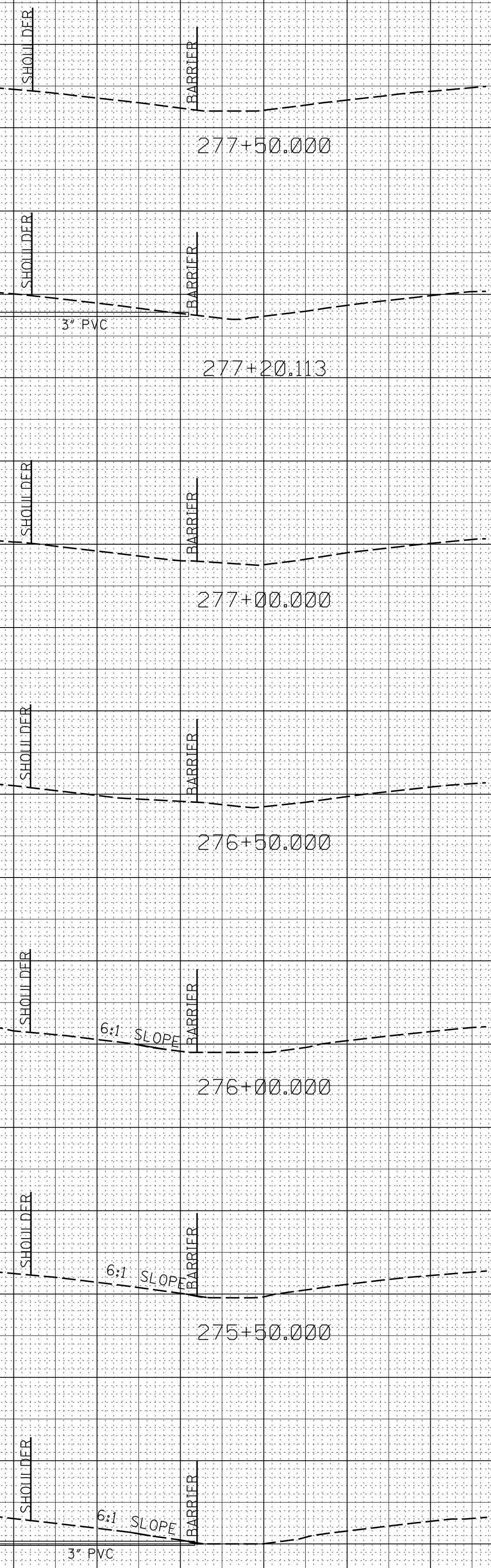

345
340
335
345
340
335
345
340
335
345
340
335
345
340
335
345
340
335

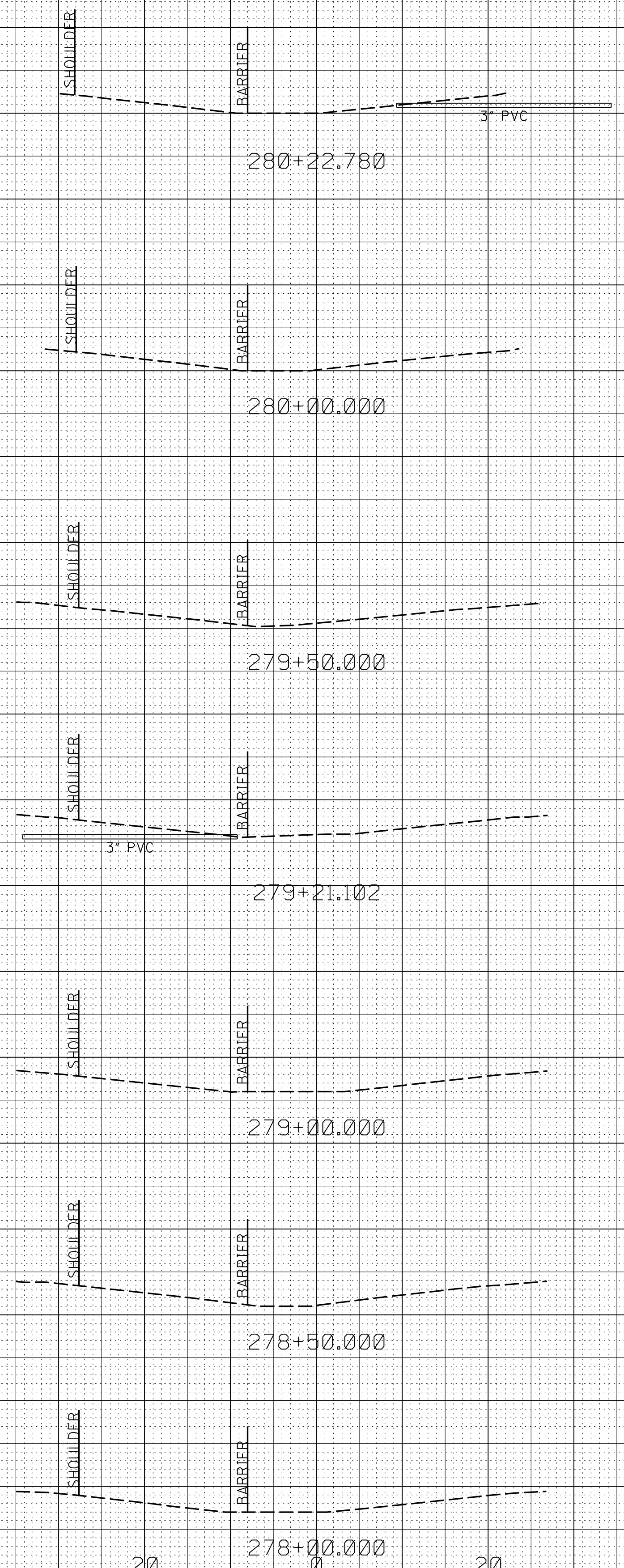

7/20/2019 8:35 AM LAY-HOLMES3.DGN

80 60 40 20 0 20 40 60 80 80 60 40 20 0 20 40

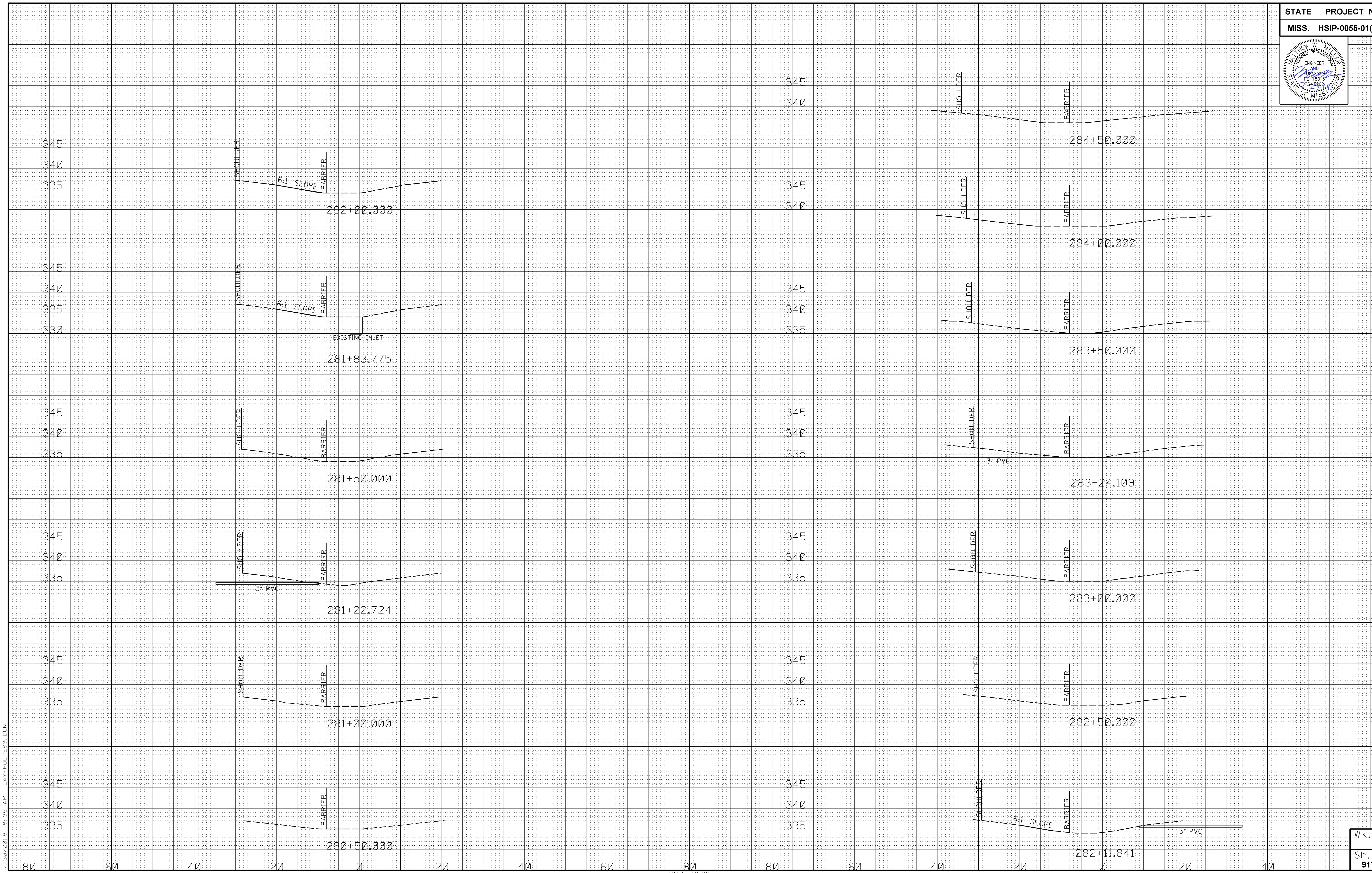
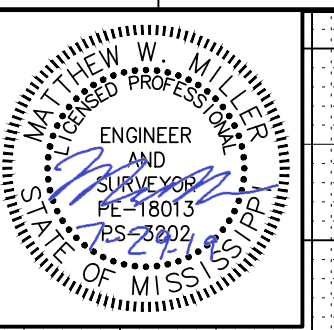

7/30/2019 8:35 AM LAY-HOLMES3.DGN

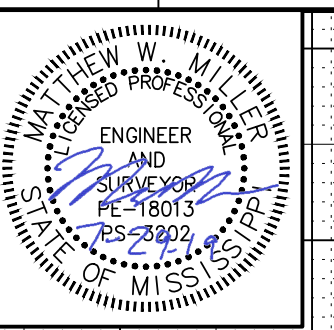

350
345
340

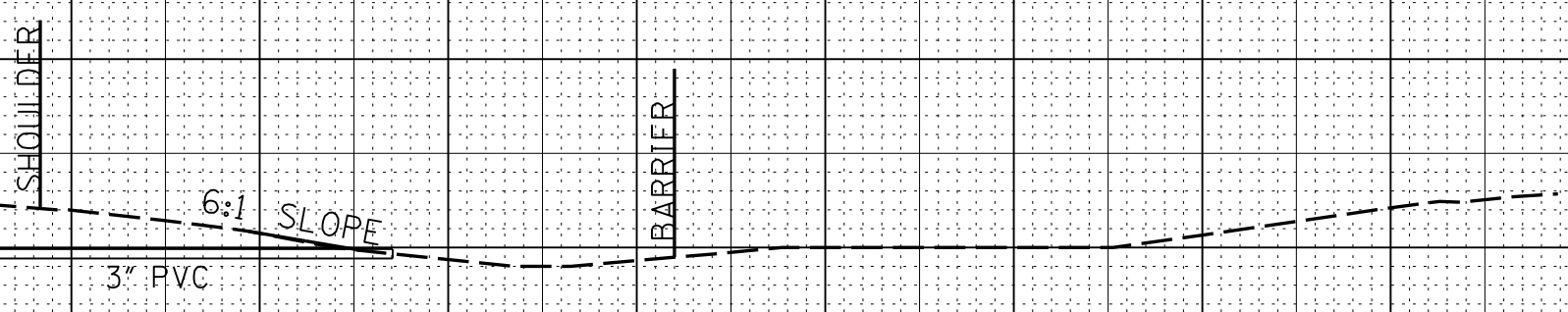

287+25.431

350
345
340

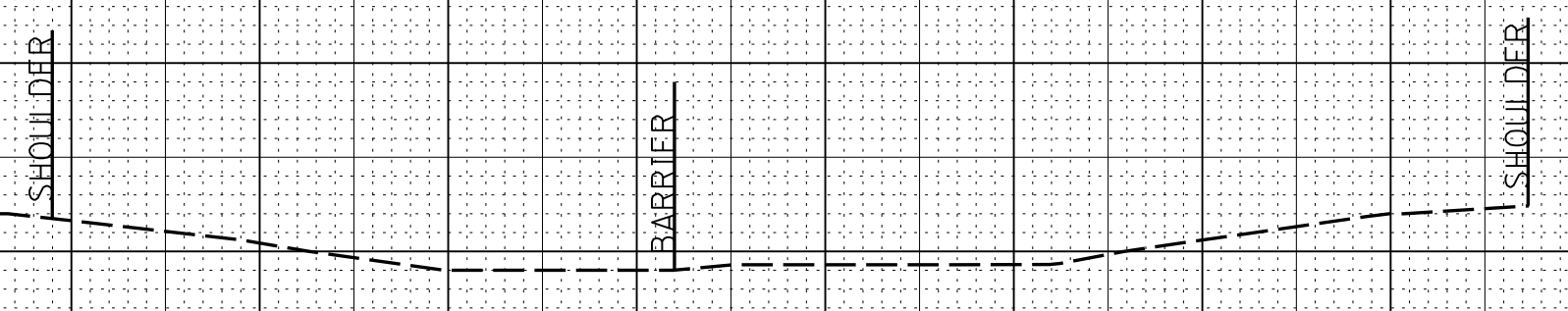

287+00.000

350
345
340

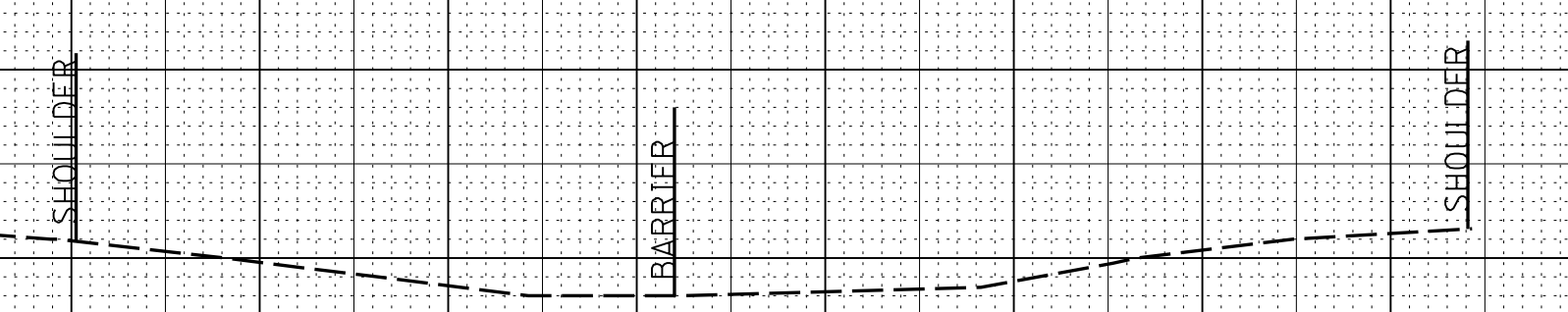

286+50.000

350
345
340

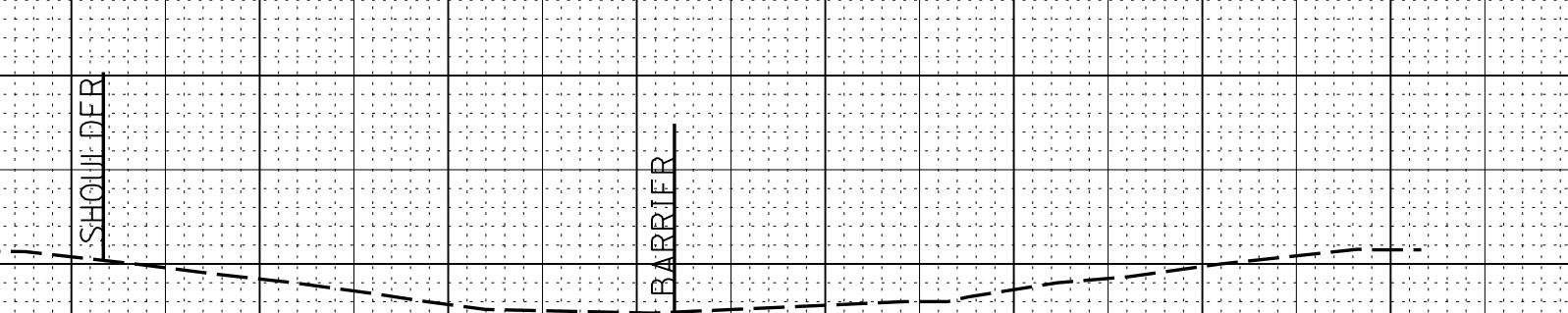

286+00.000

345
340

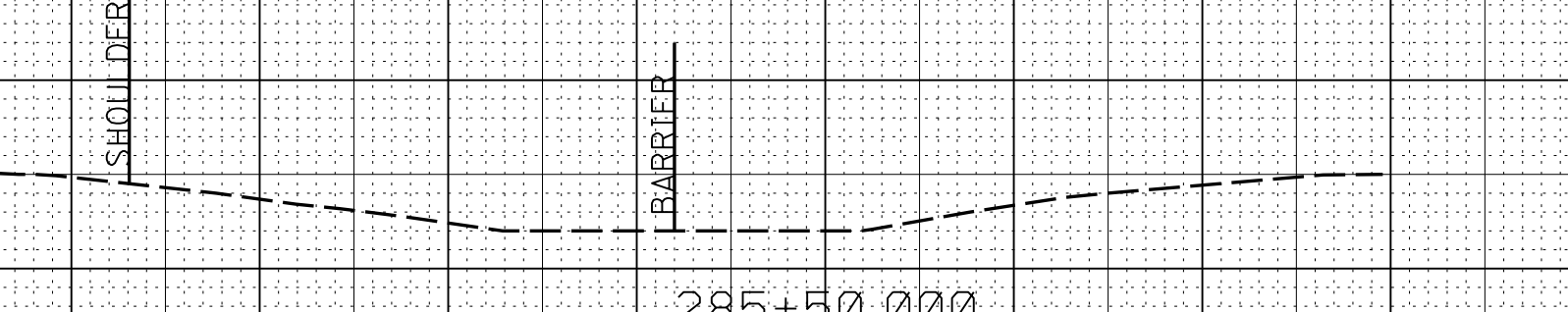

285+50.000

350
345

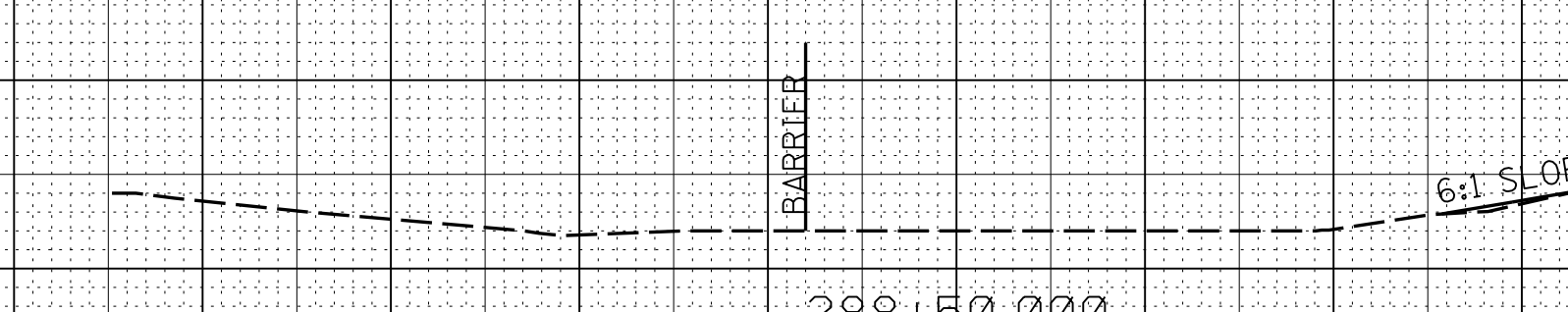

288+50.000

345
340
335

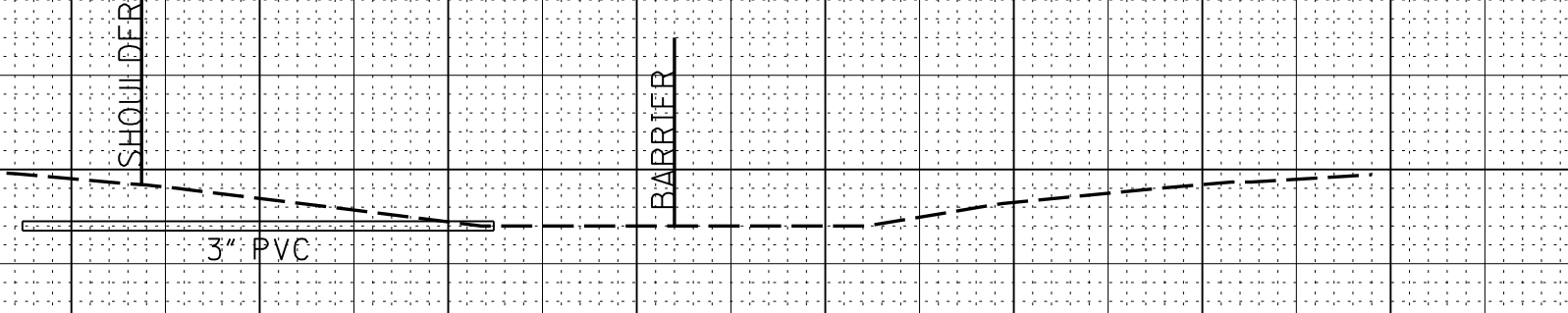

285+24.965

350
345

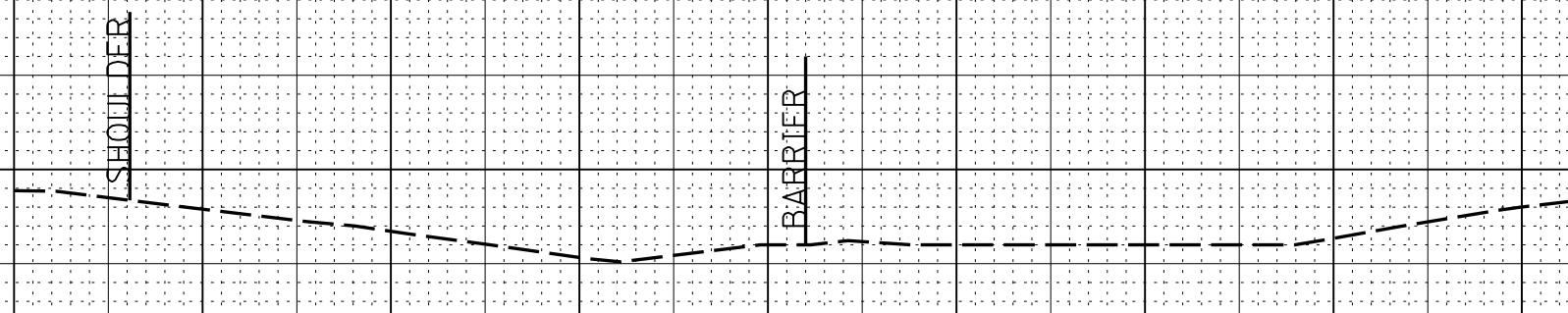

288+00.000

345
340

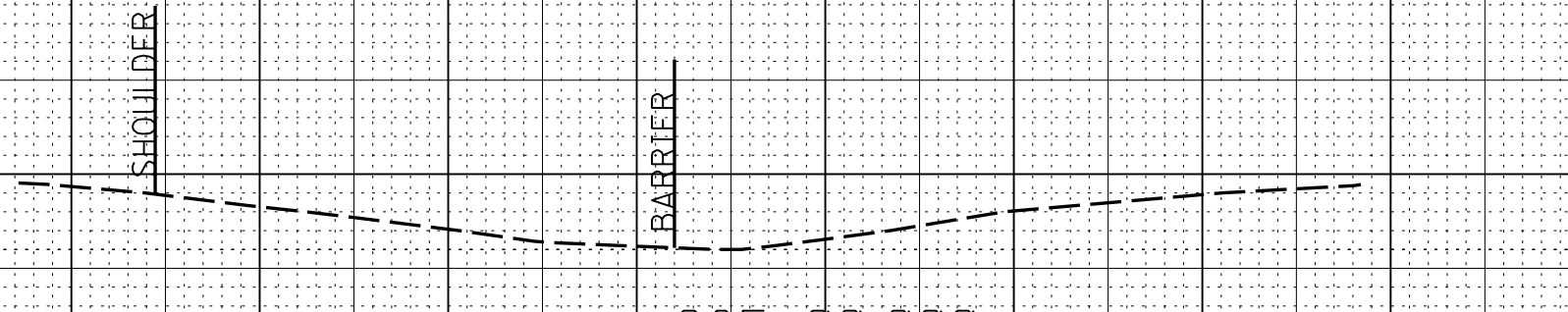

285+00.000

350
345
340

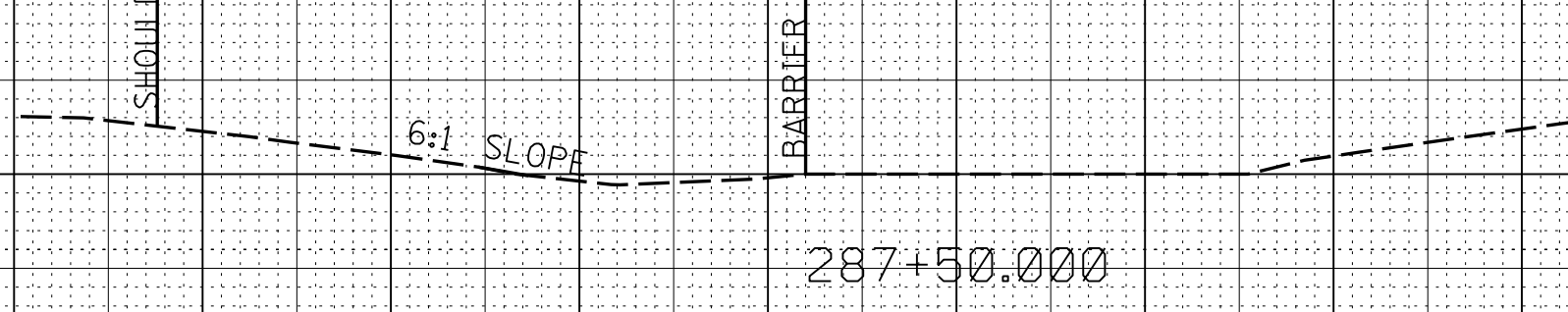

287+50.000

7/30/2019 8:35 AM LAY-HOLMES3.DGN

80 60 40 20 0 20 40 60 80 80 60 40 20 0 20 40

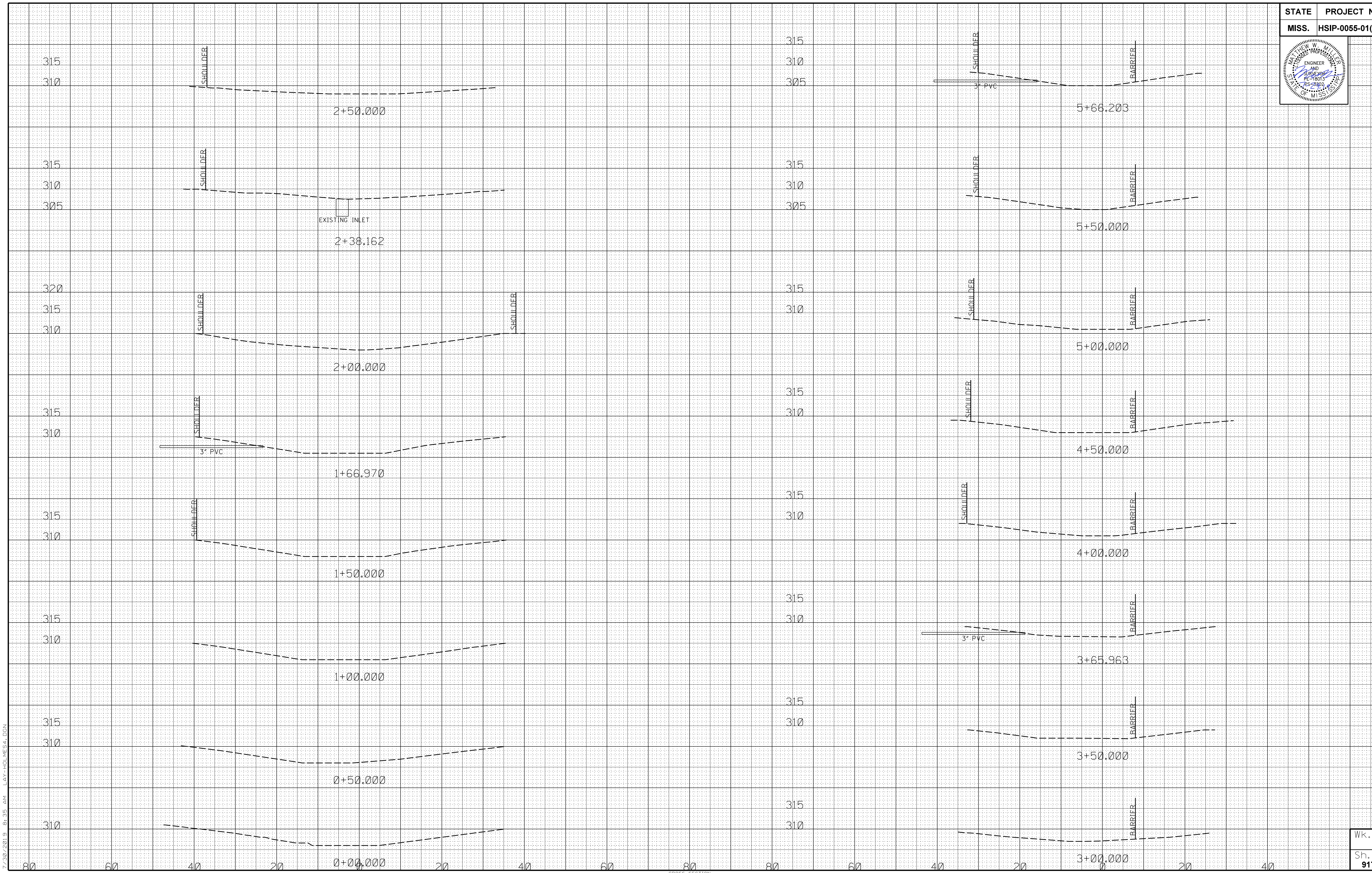
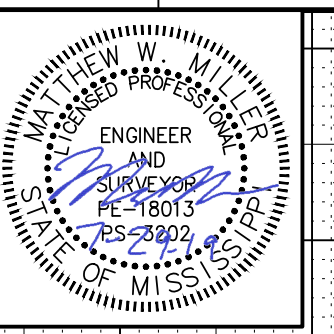

7/30/2019 8:35 AM LAY-HOLMES4.DGN

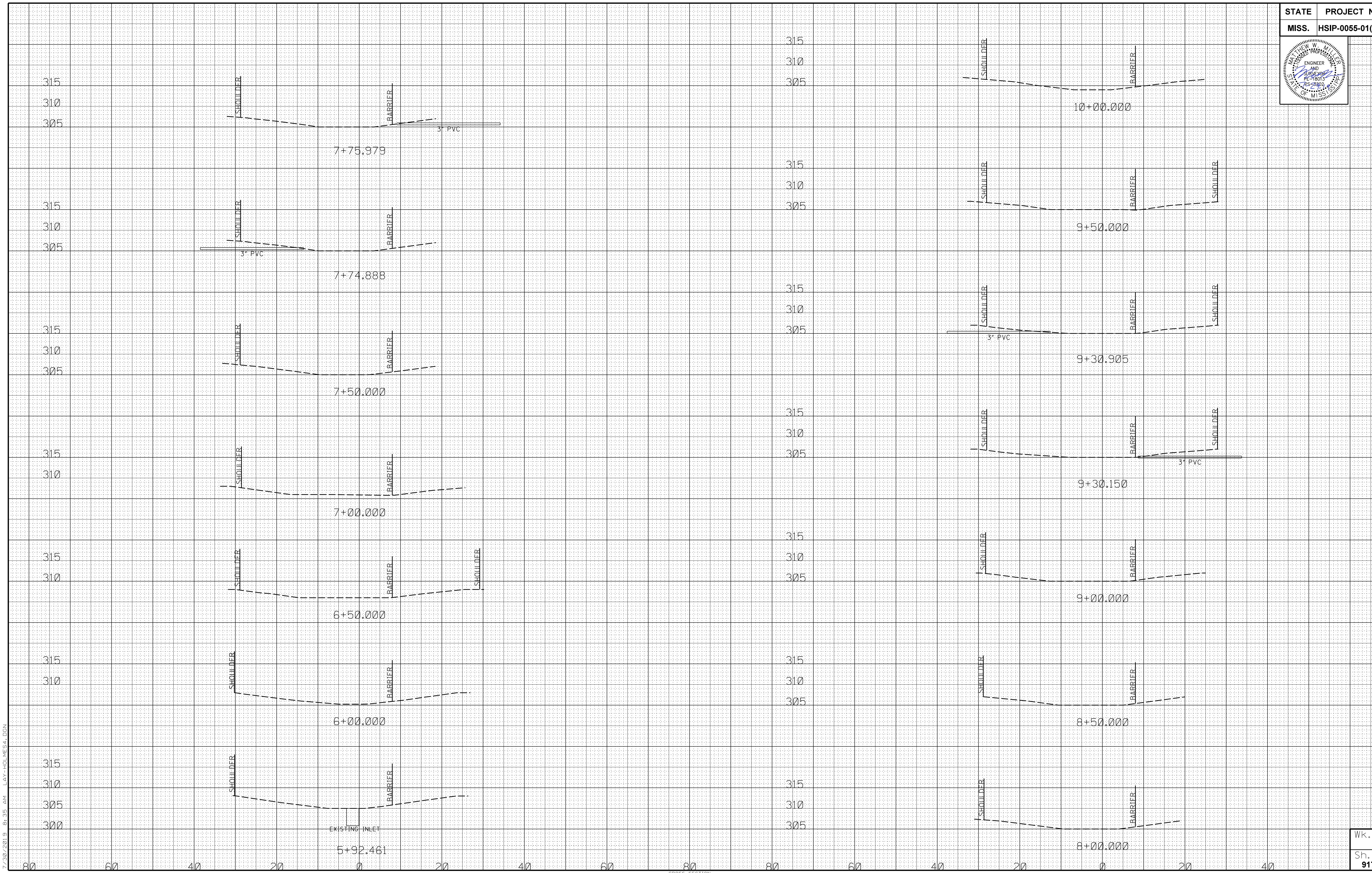
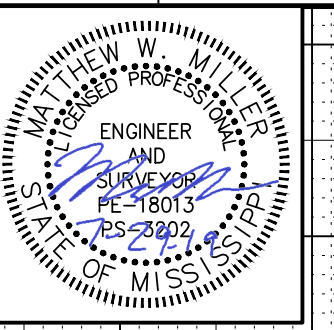

7/30/2019 8:35 AM LAY-HOLMES4.DGN

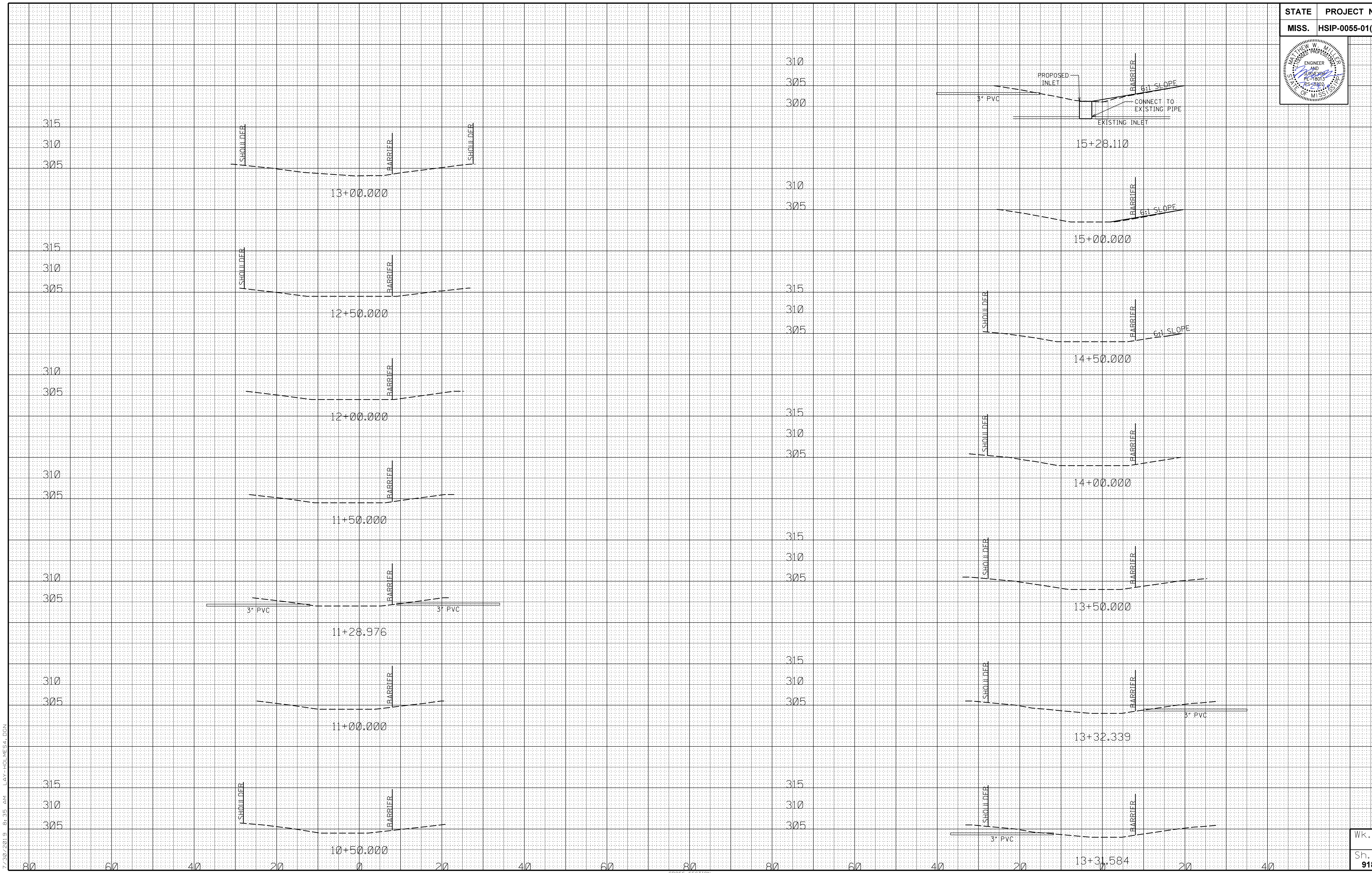
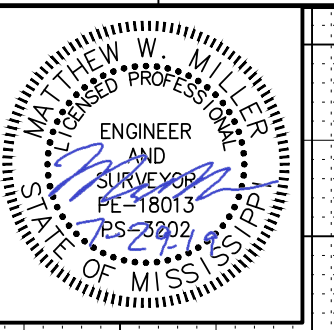

7/30/2019 8:35 AM LAY-HOLMES4.DGN

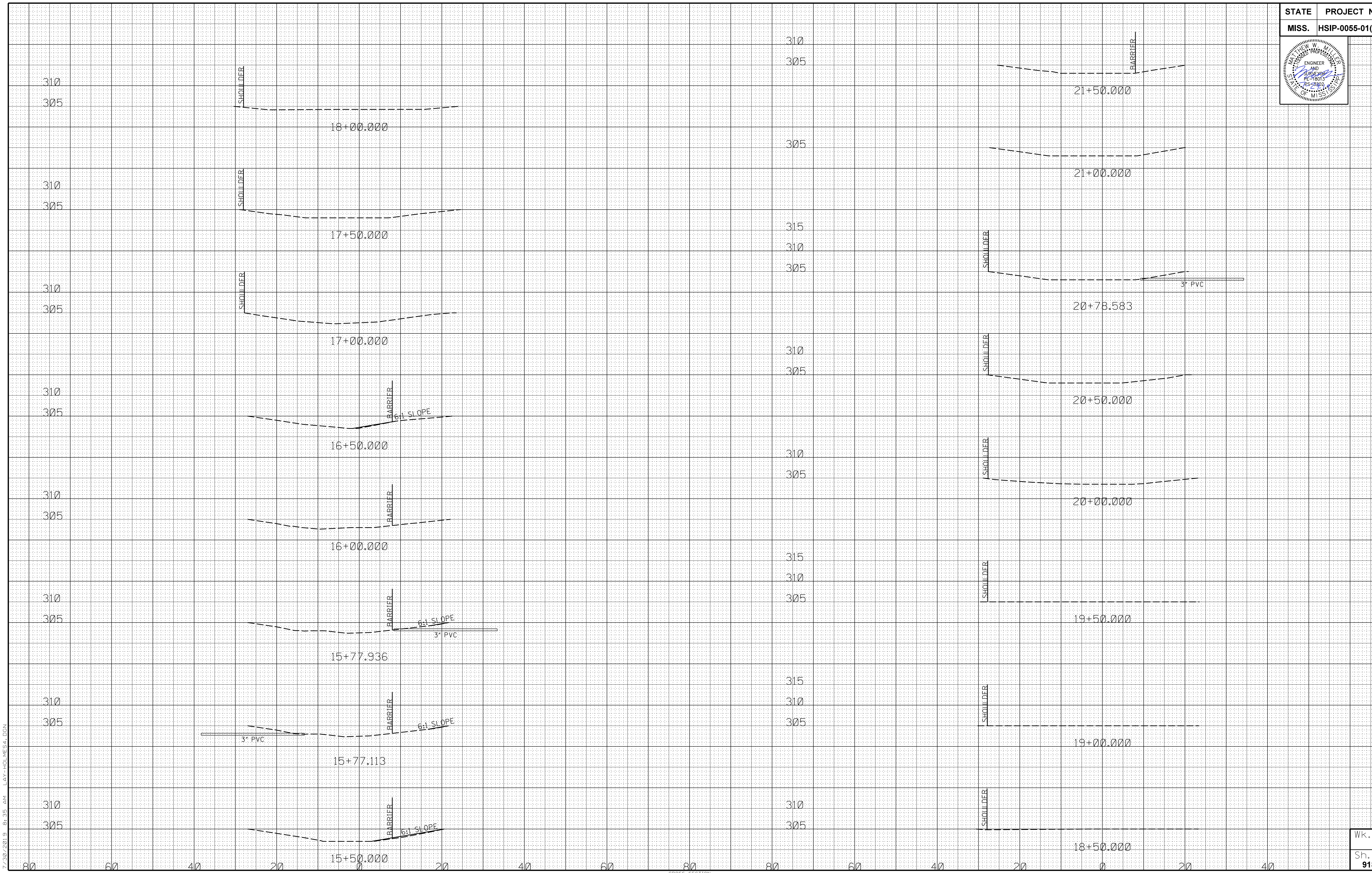
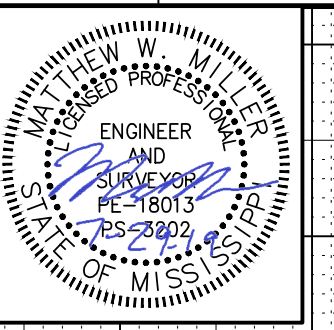

7/30/2019 8:35 AM LAY-HOLMES4.DGN

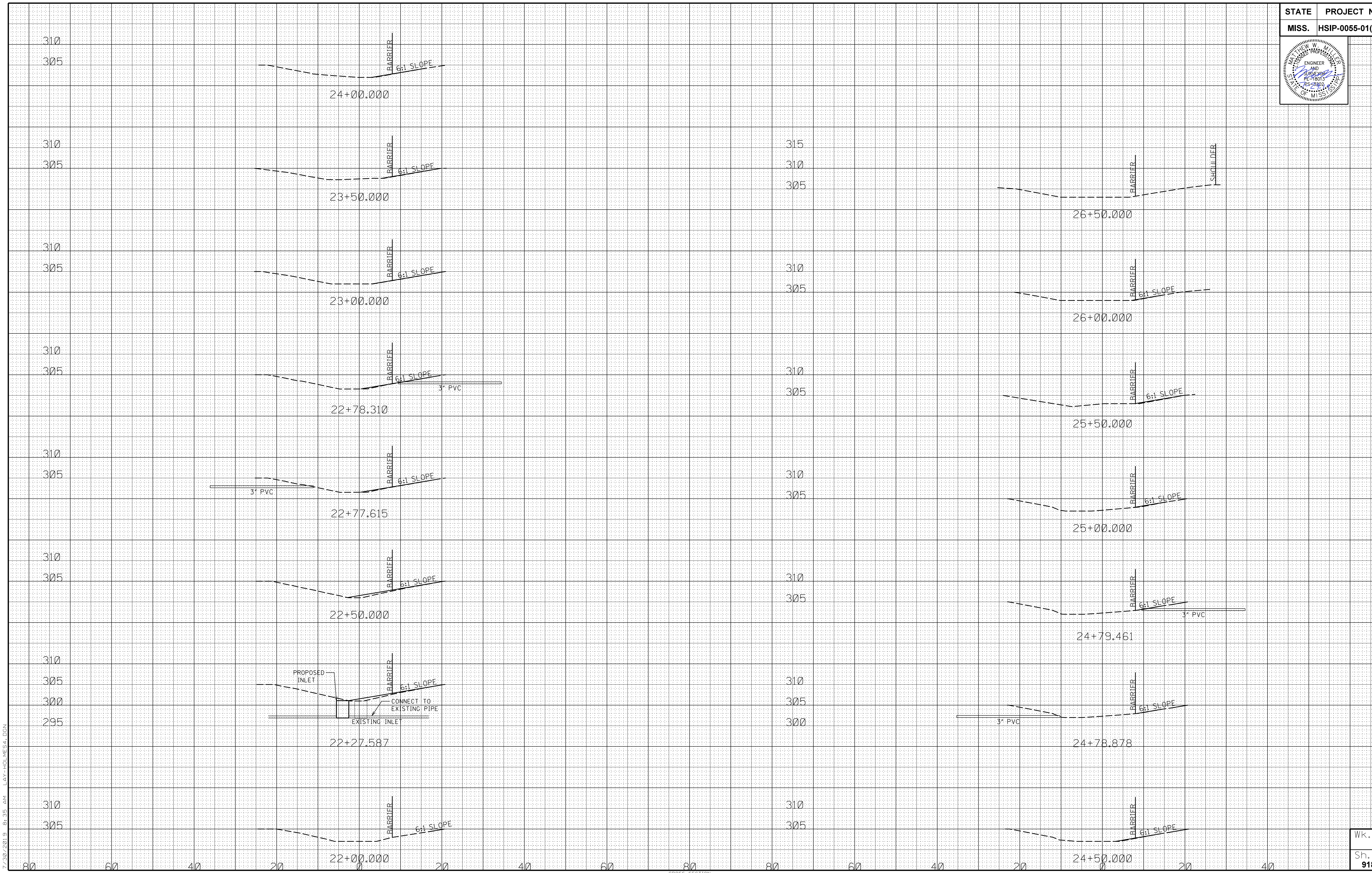
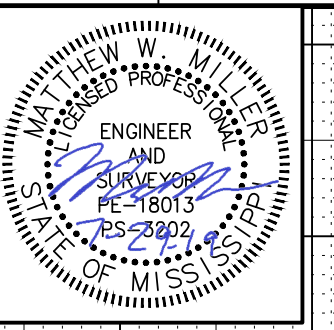

7/30/2019 8:35 AM LAY-HOLMES4.DGN

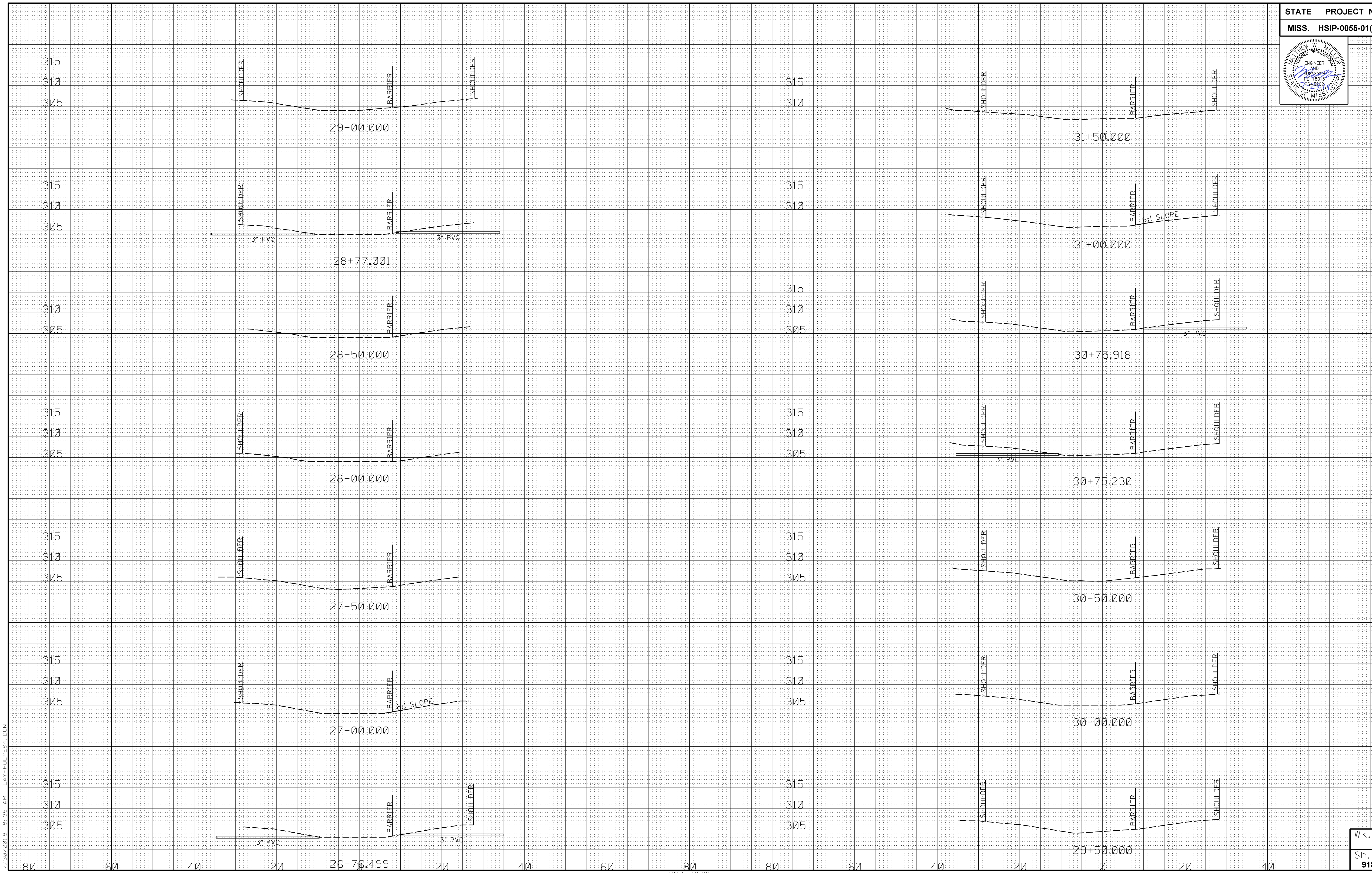
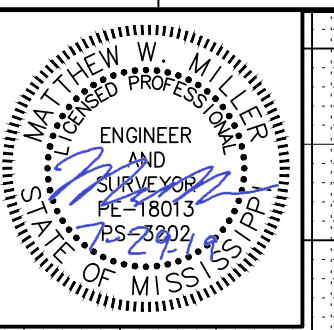

7/30/2019 8:35 AM LAY-HOLMES4.DGN

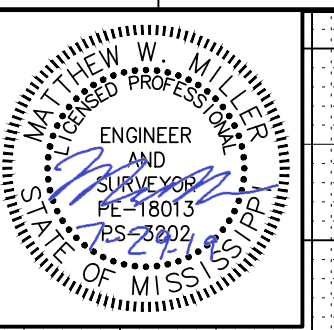

320
315
310
320
315
310
320
315
310
320
315
310
320
315
310
320
315
310
315
310

34+50.000

34+00.000

33+50.000

33+00.000

32+50.000

32+20.770

32+00.000

SHOULDER

BARRIER

SHOULDER

SHOULDER

BARRIER

SHOULDER

SHOULDER

BARRIER

SHOULDER

SHOULDER

BARRIER

SHOULDER

SHOULDER

BARRIER

SHOULDER

SHOULDER

BARRIER

SHOULDER

SHOULDER

BARRIER

SHOULDER

24" RCP

7/30/2019 8:35 AM LAY-HOLMES4.DGN

80 60 40 20 0 20 40 60 80 80 60 40 20 35+00.000 20 40

325
320
315
310
325
320
315
310
325
320
315
310
325
320
315
310
320
315
310

37+00.000

36+50.000

36+00.000

35+86.502

35+50.000

35+00.000

SHOULDER

BARRIER

SHOULDER

SHOULDER

BARRIER

SHOULDER

SHOULDER

BARRIER

SHOULDER

SHOULDER

BARRIER

SHOULDER

SHOULDER

BARRIER

SHOULDER

SHOULDER

BARRIER

SHOULDER

PAVED DITCH

PROPOSED PAVED DITCH

PAVED DITCH

PROPOSED PAVED DITCH

PAVED DITCH

6:1 SLOPE

6:1 SLOPE

6:1 SLOPE

6:1 SLOPE

24" RCP

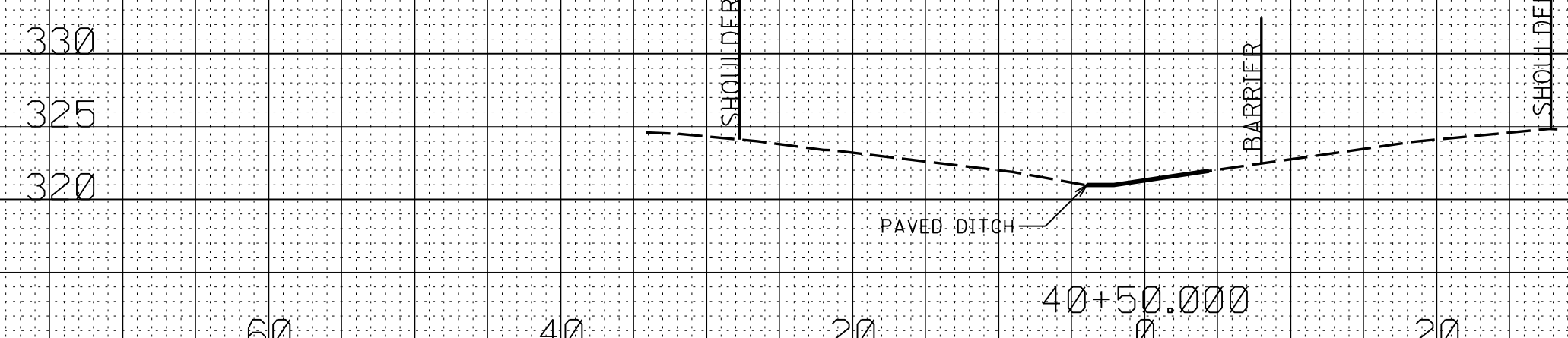
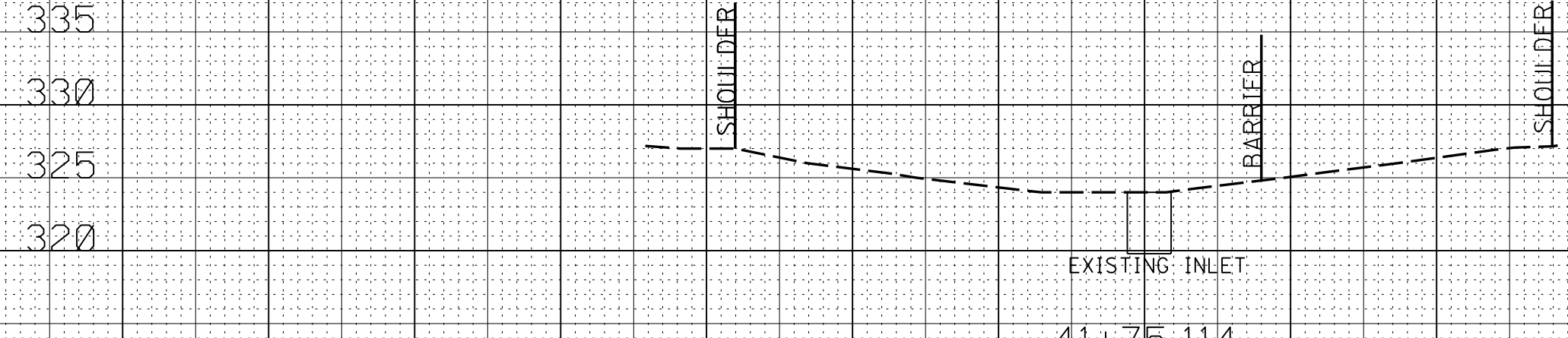
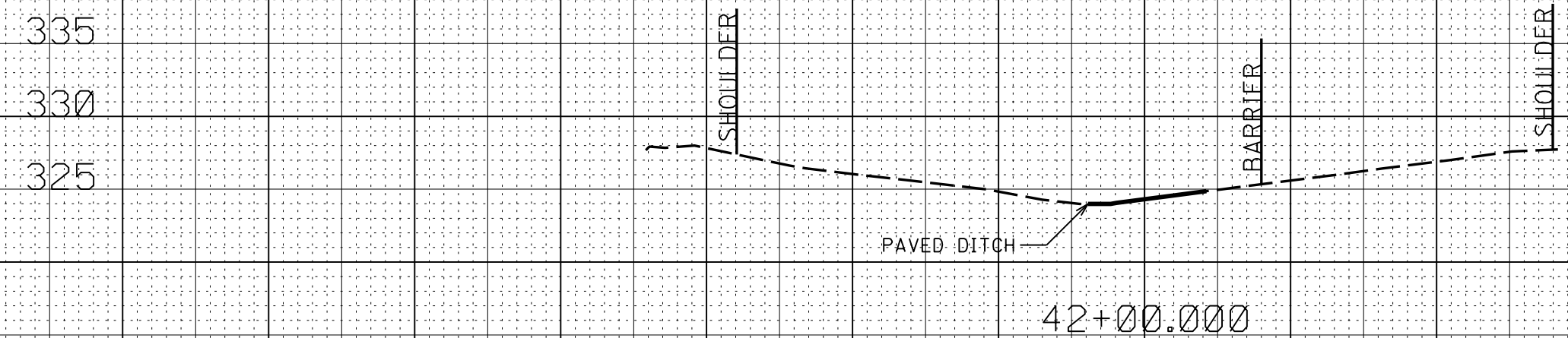
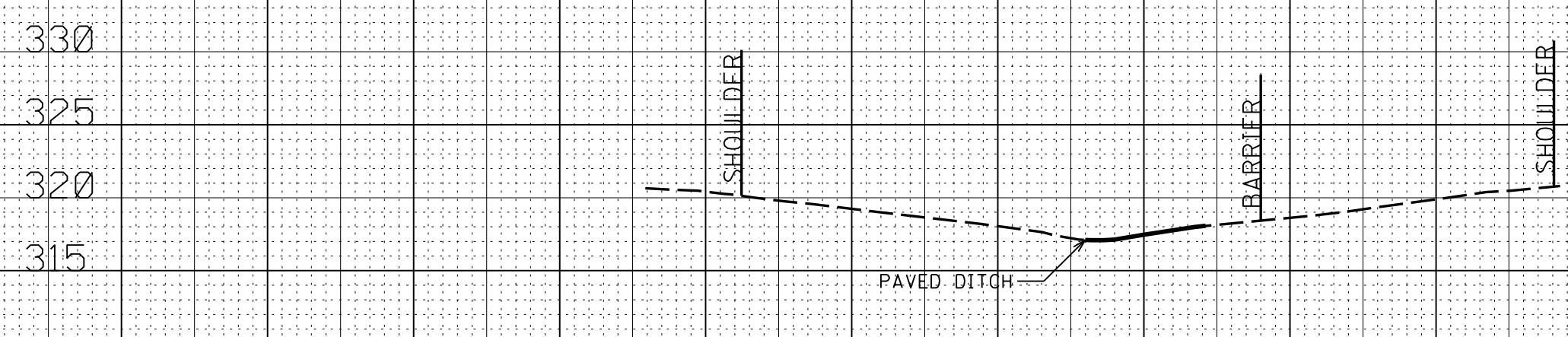
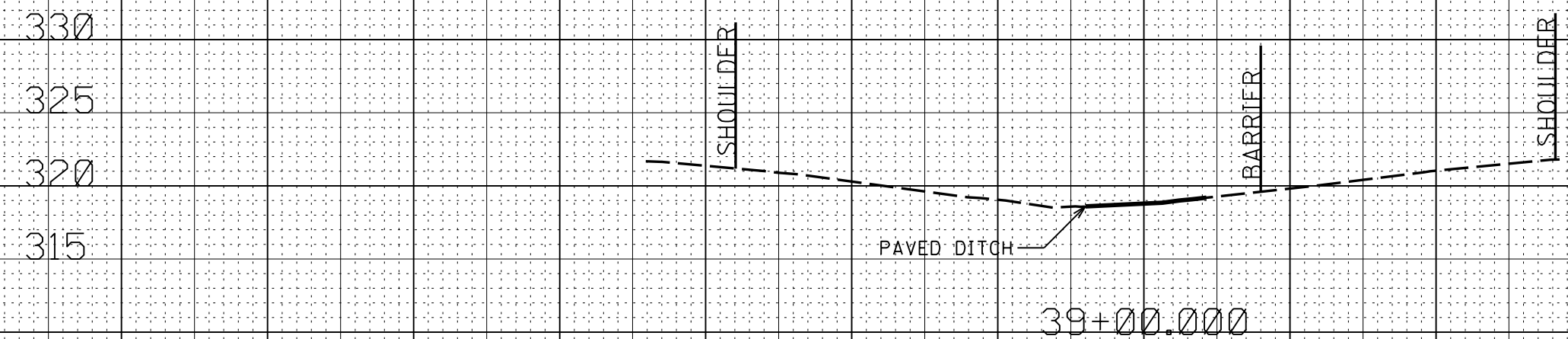
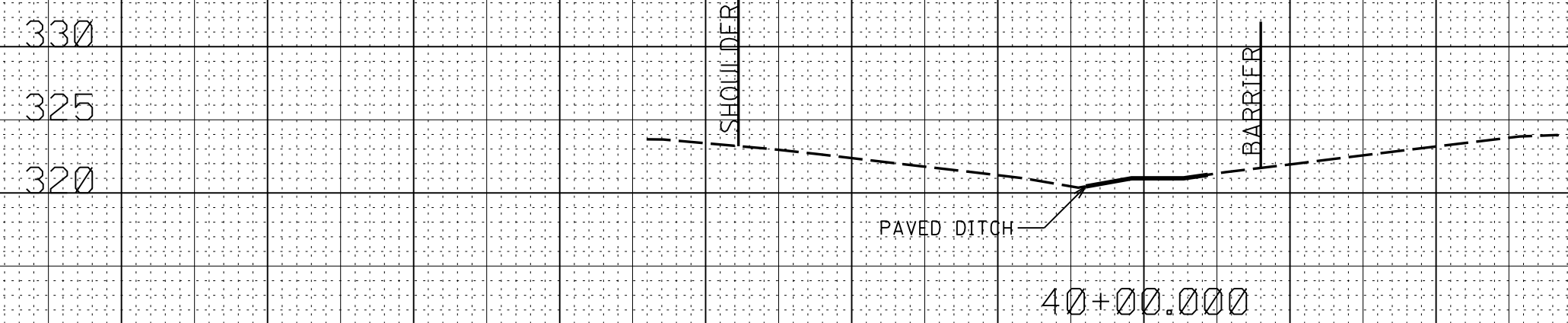
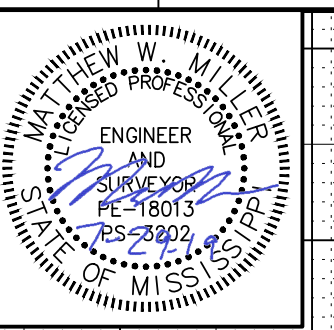

7/30/2019 8:35 AM LAY-HOLMES4.DGN

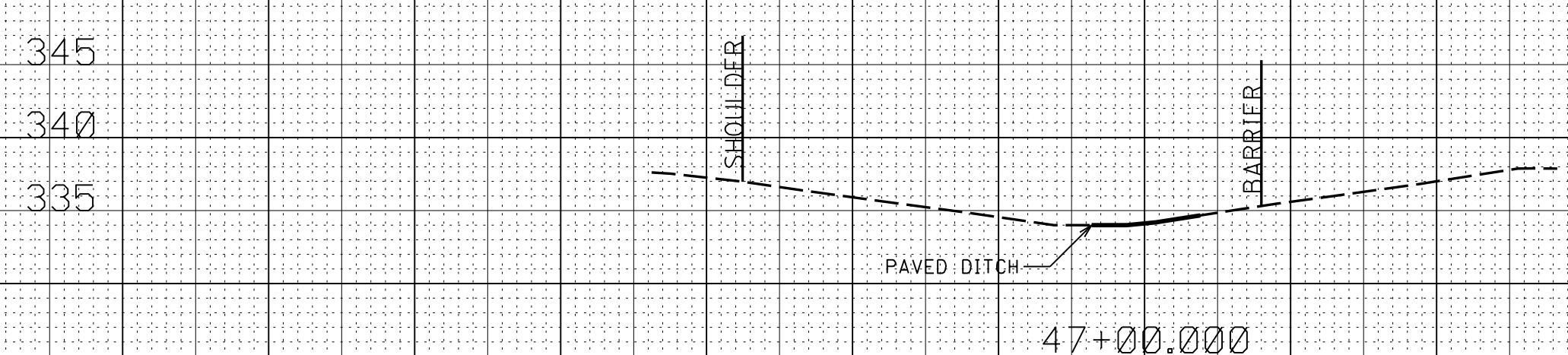
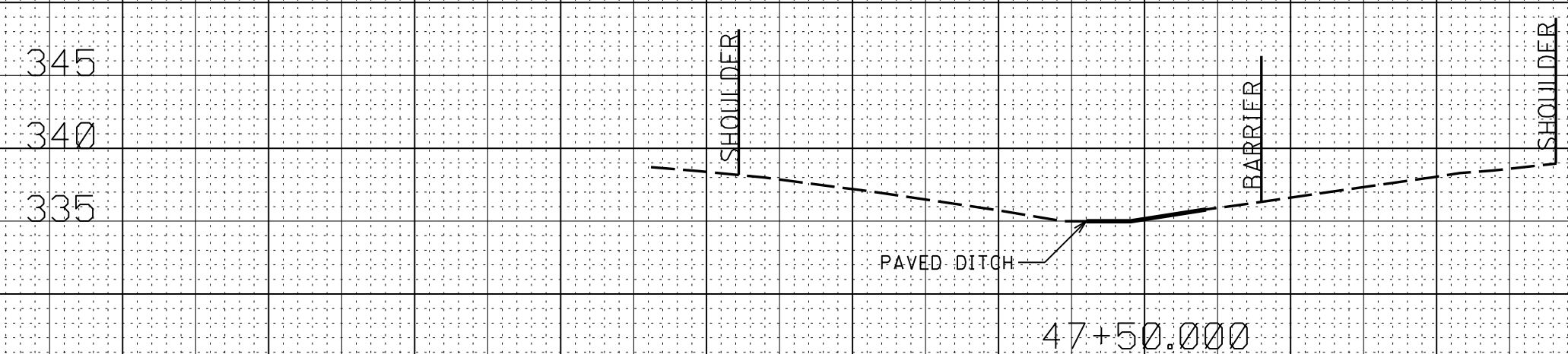
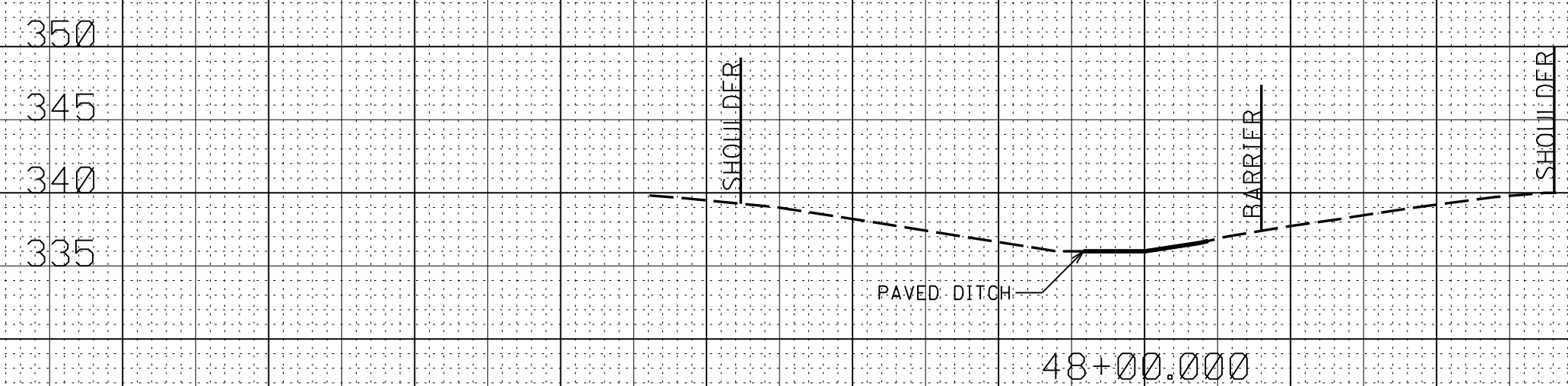
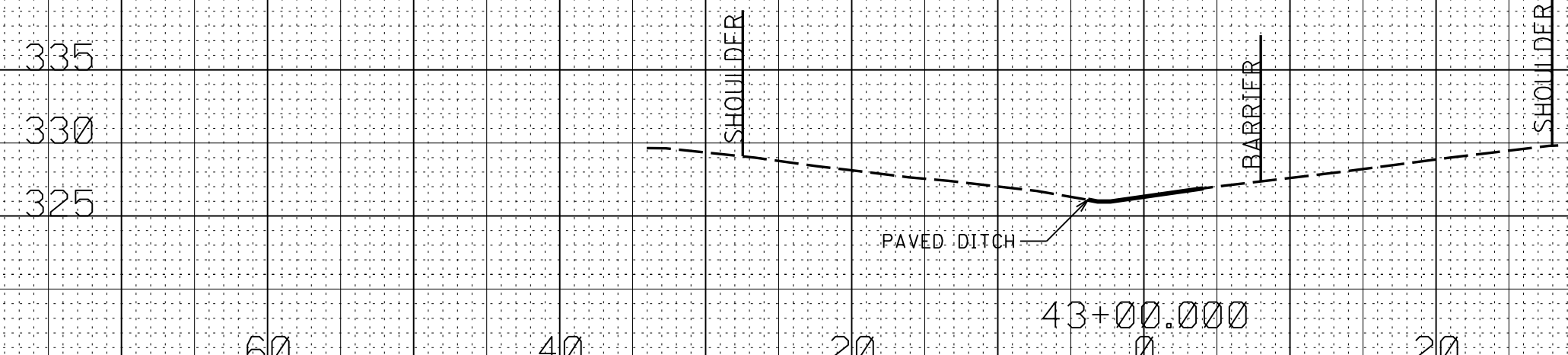
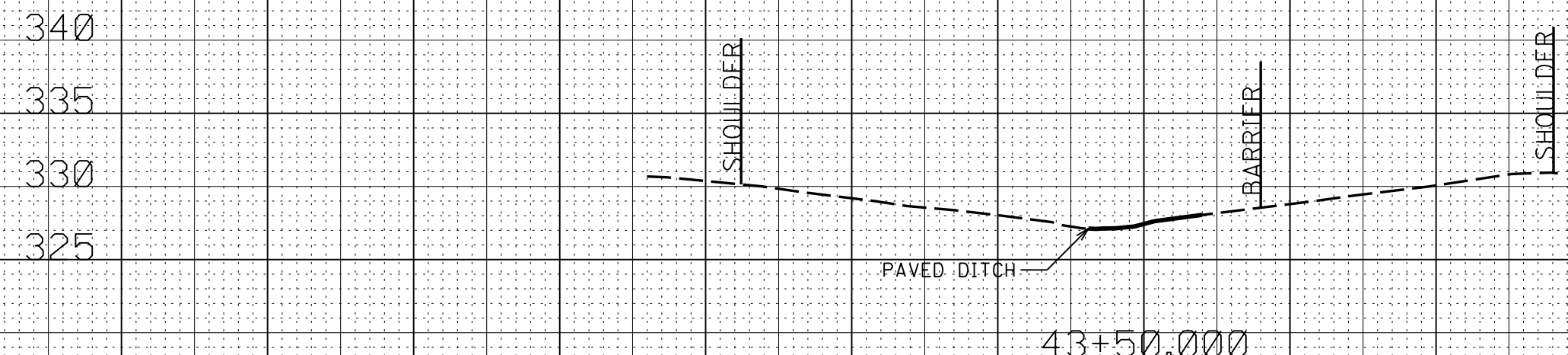
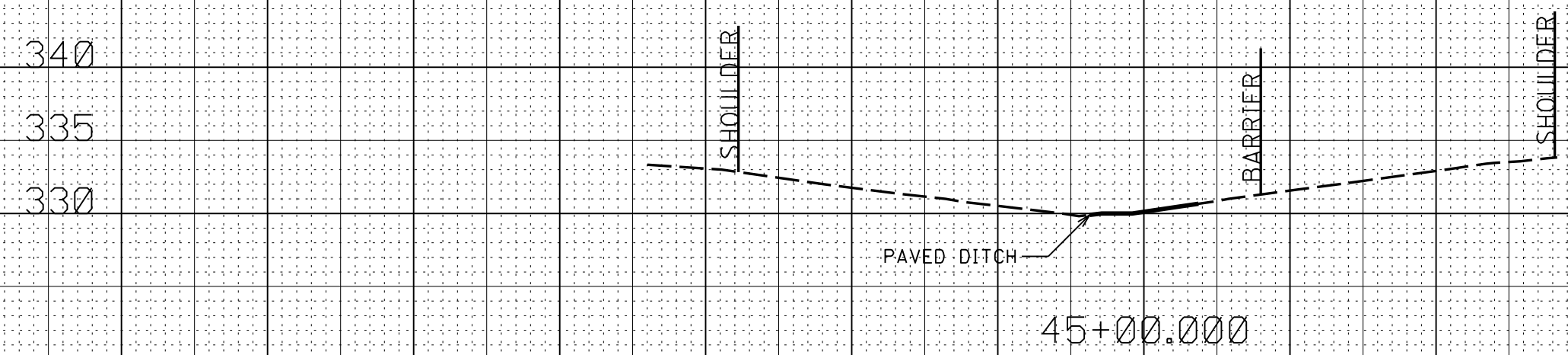
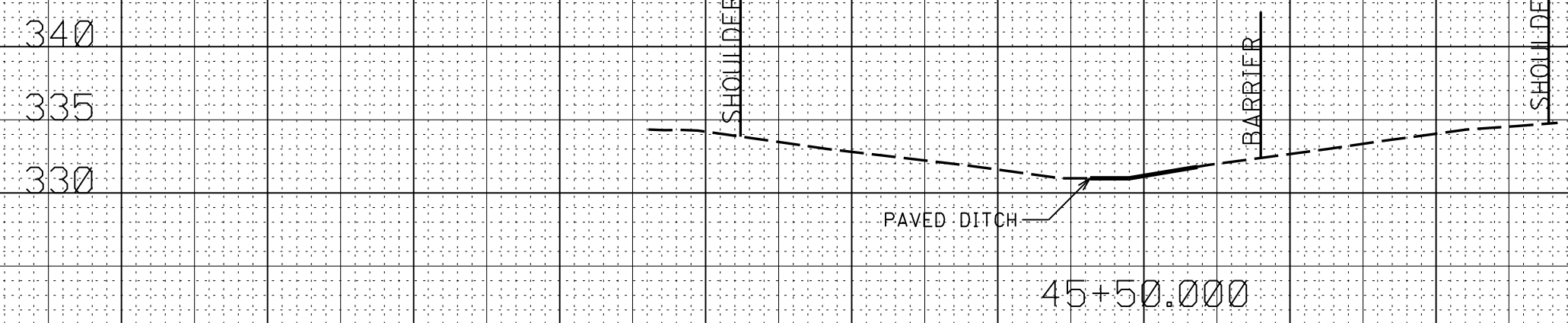
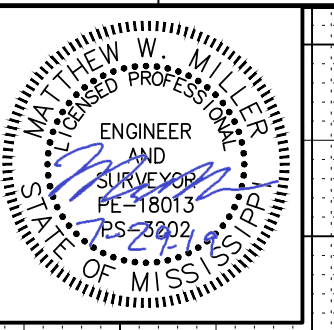

7/30/2019 8:35 AM LAY-HOLMES4.DGN

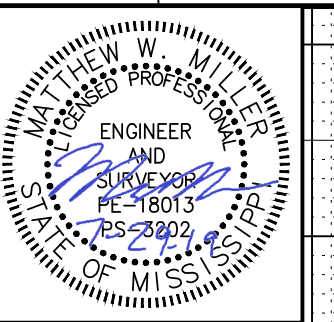

355
350
345
340
355
350
345
340
350
345
340
350
345
340
350
345
340
350
345
340
350
345
340

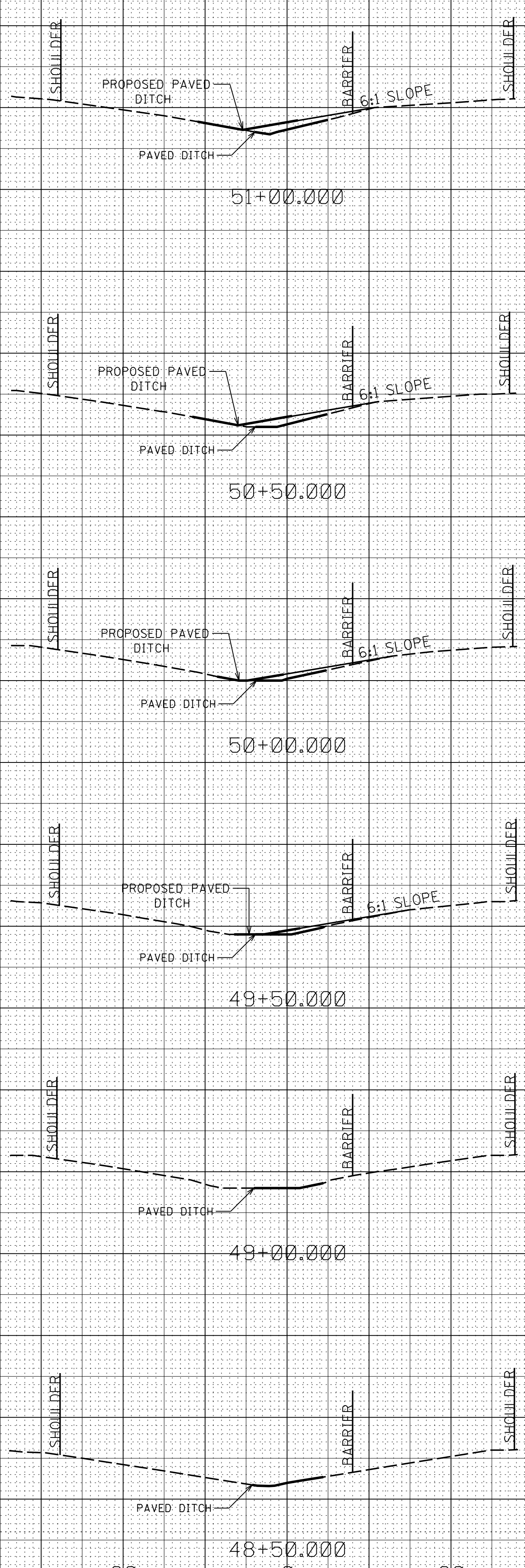

360
355
360
355
360
355
350
355
350
345
355
350
345
355
350
340

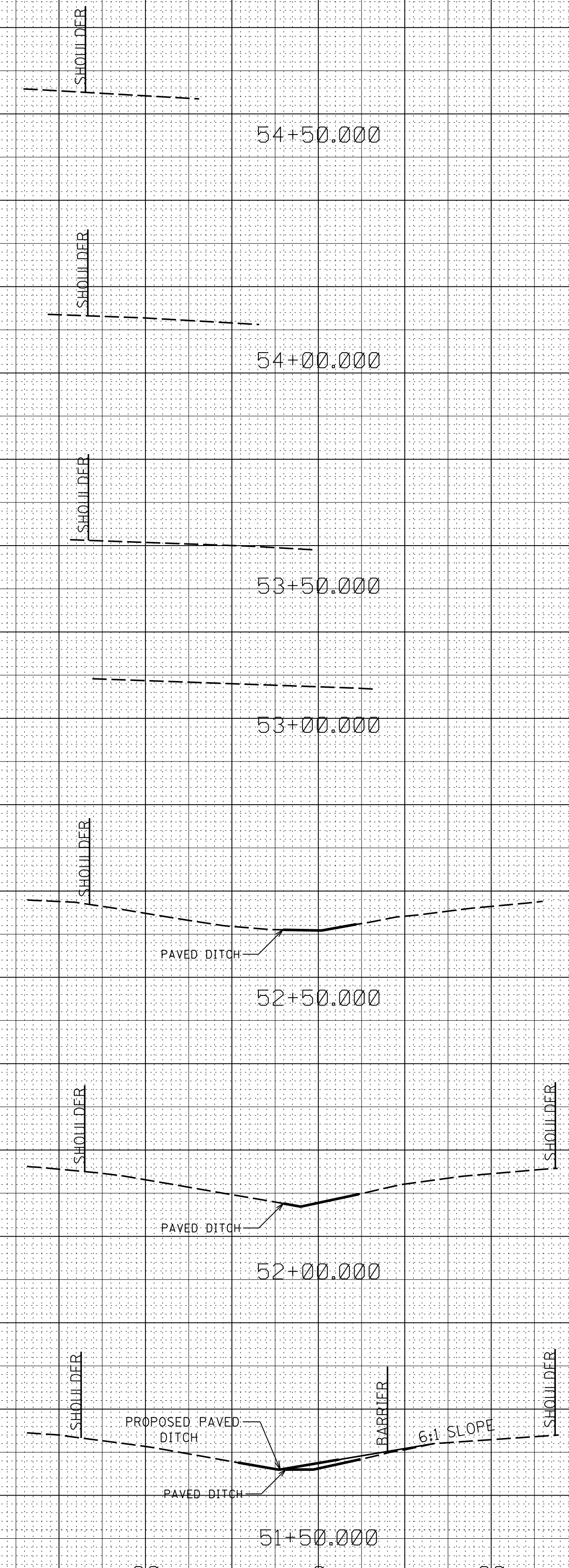

7/30/2019 8:35 AM LAY-HOLMES4.DGN

80 60 40 20 0 20 40 60 80 80 60 40 20 40

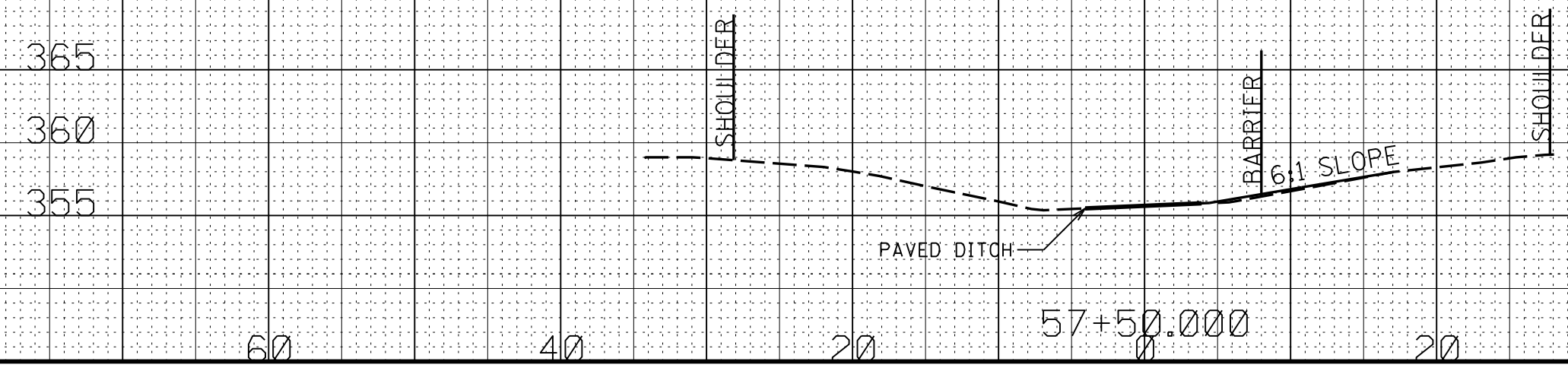
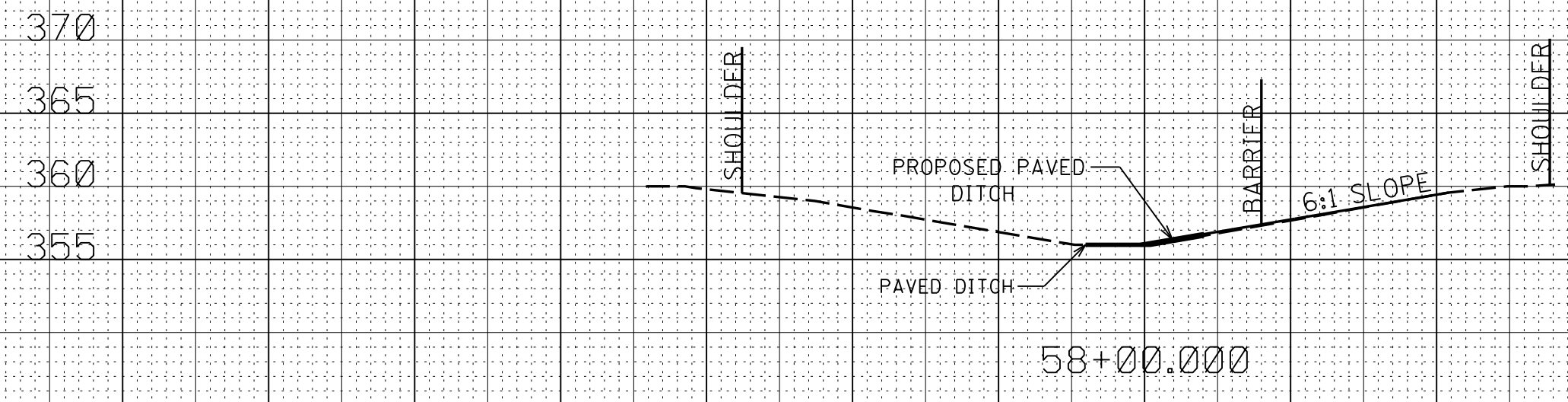
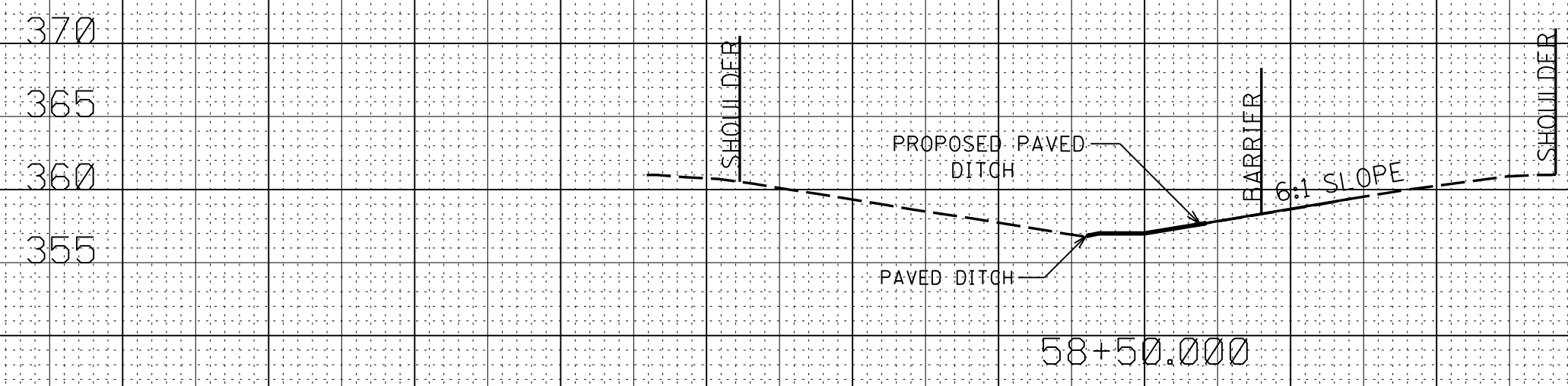
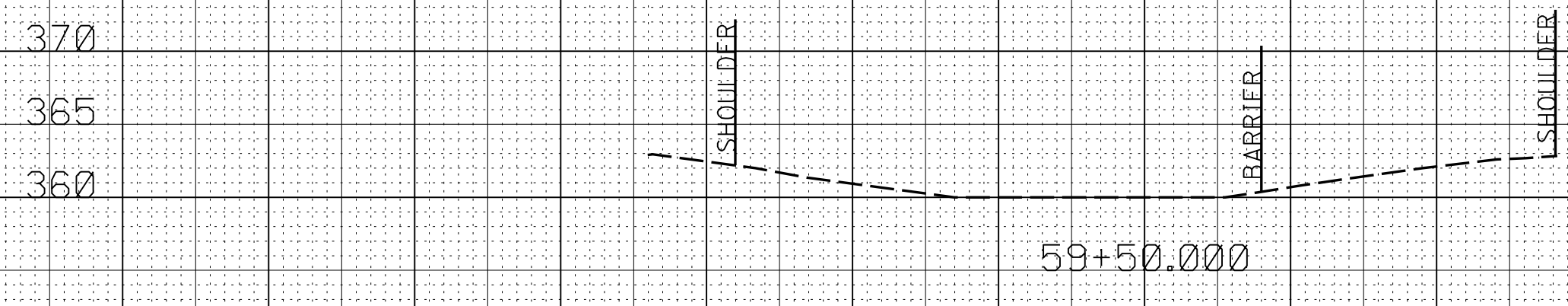
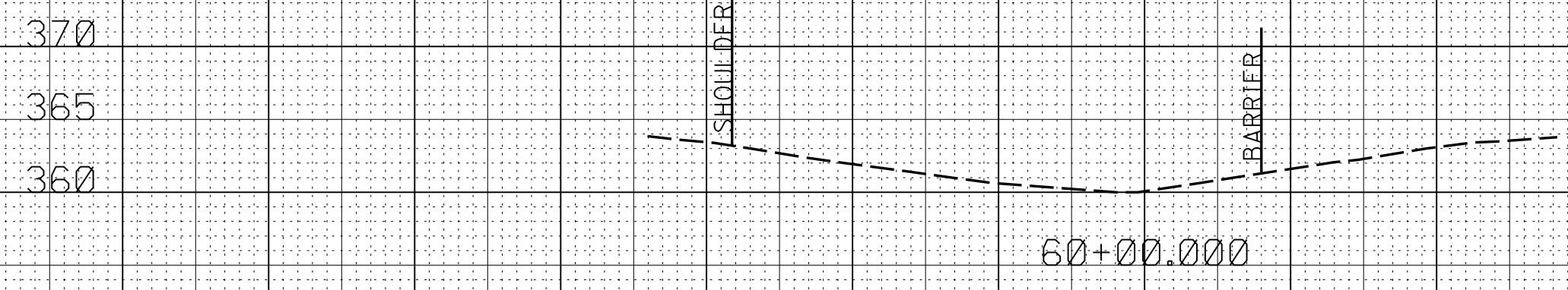
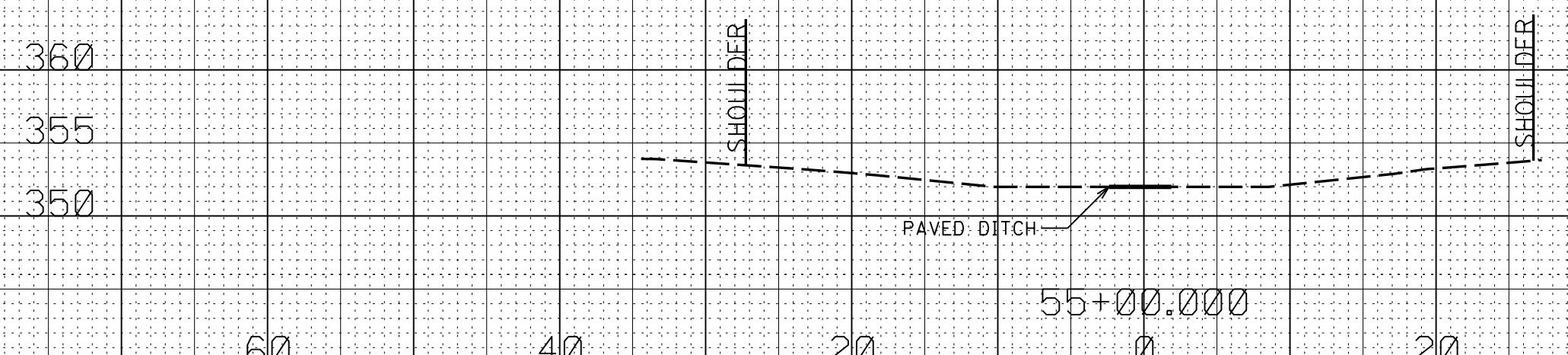
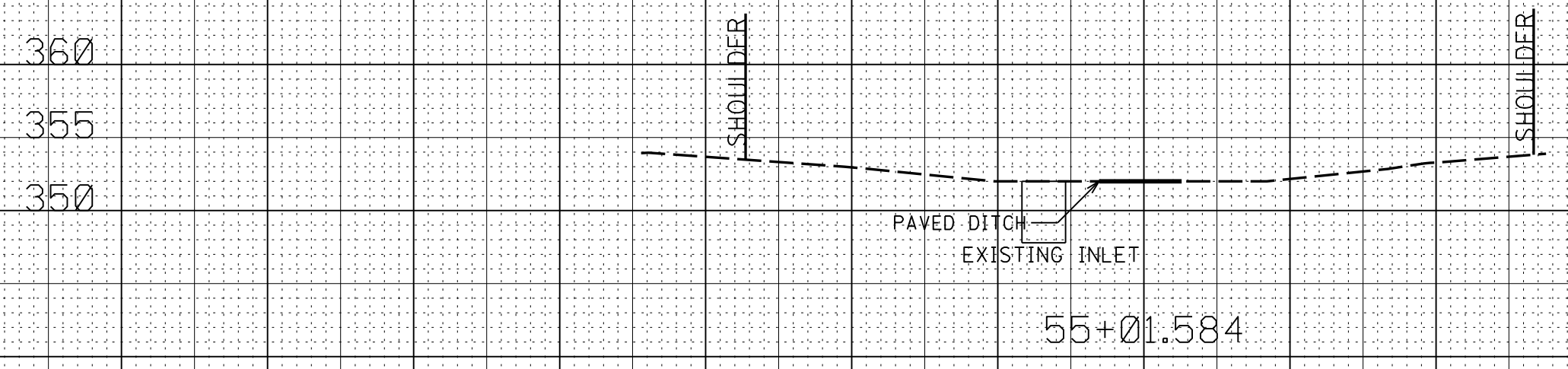
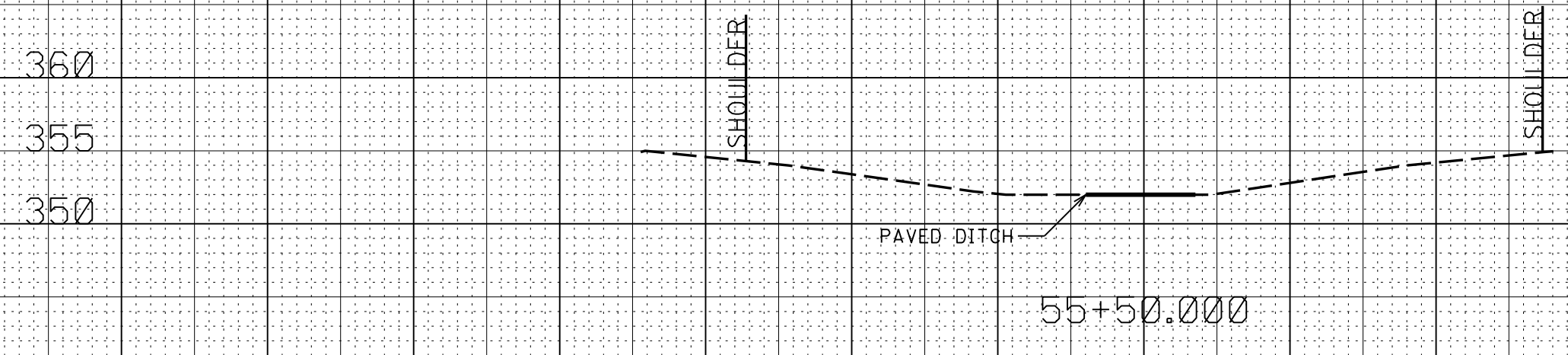
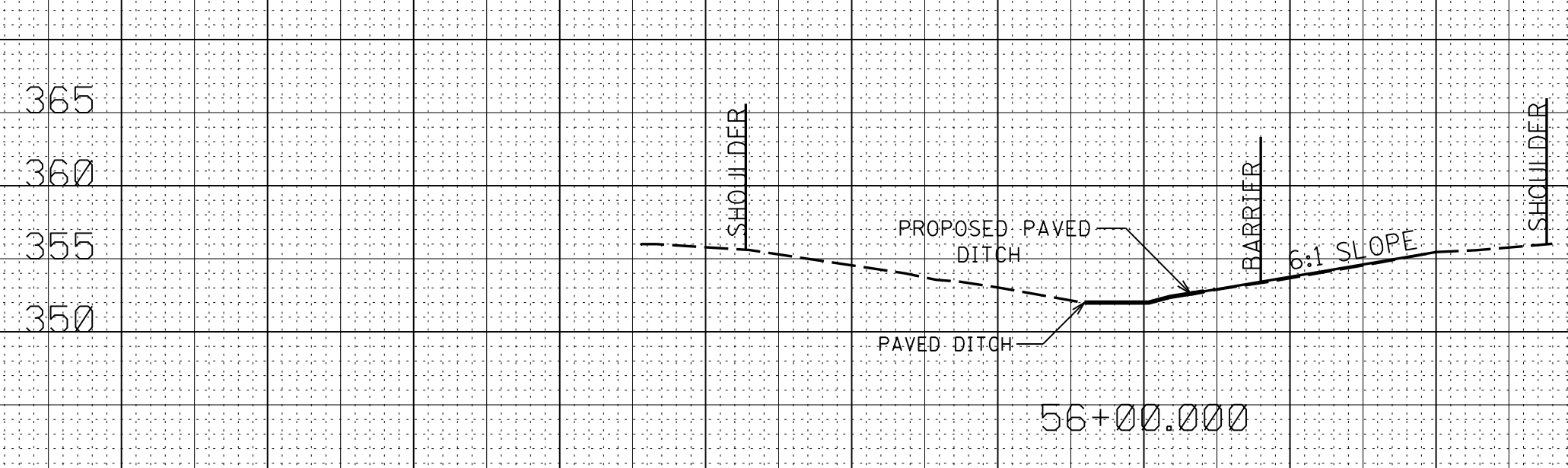
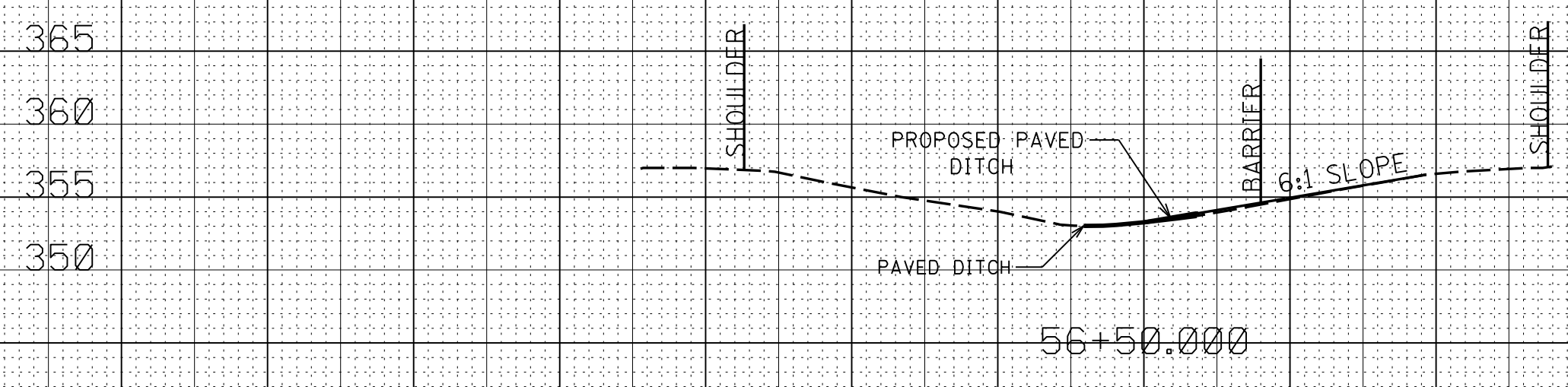
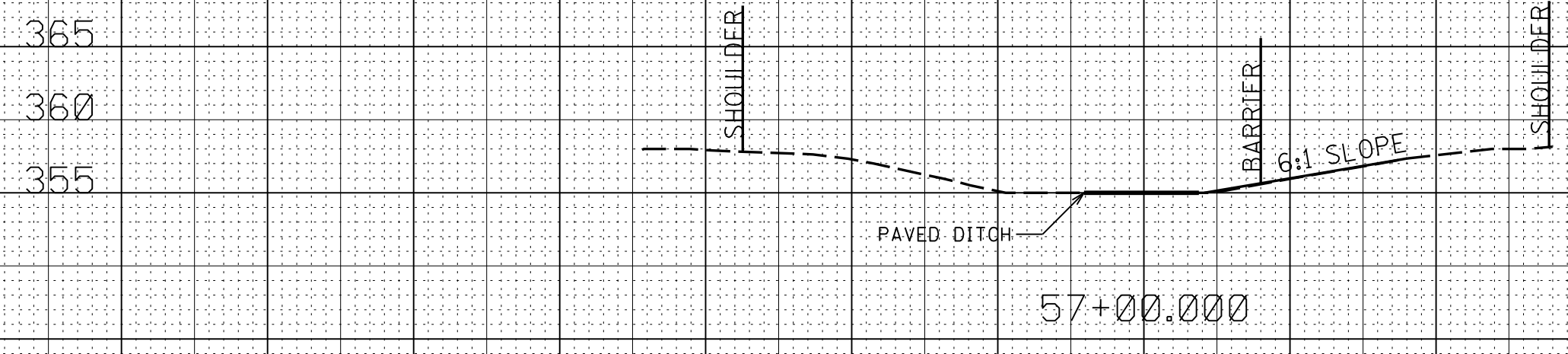
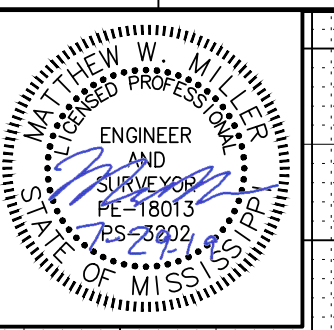

7/30/2019 8:35 AM LAY-HOLMES4.DGN

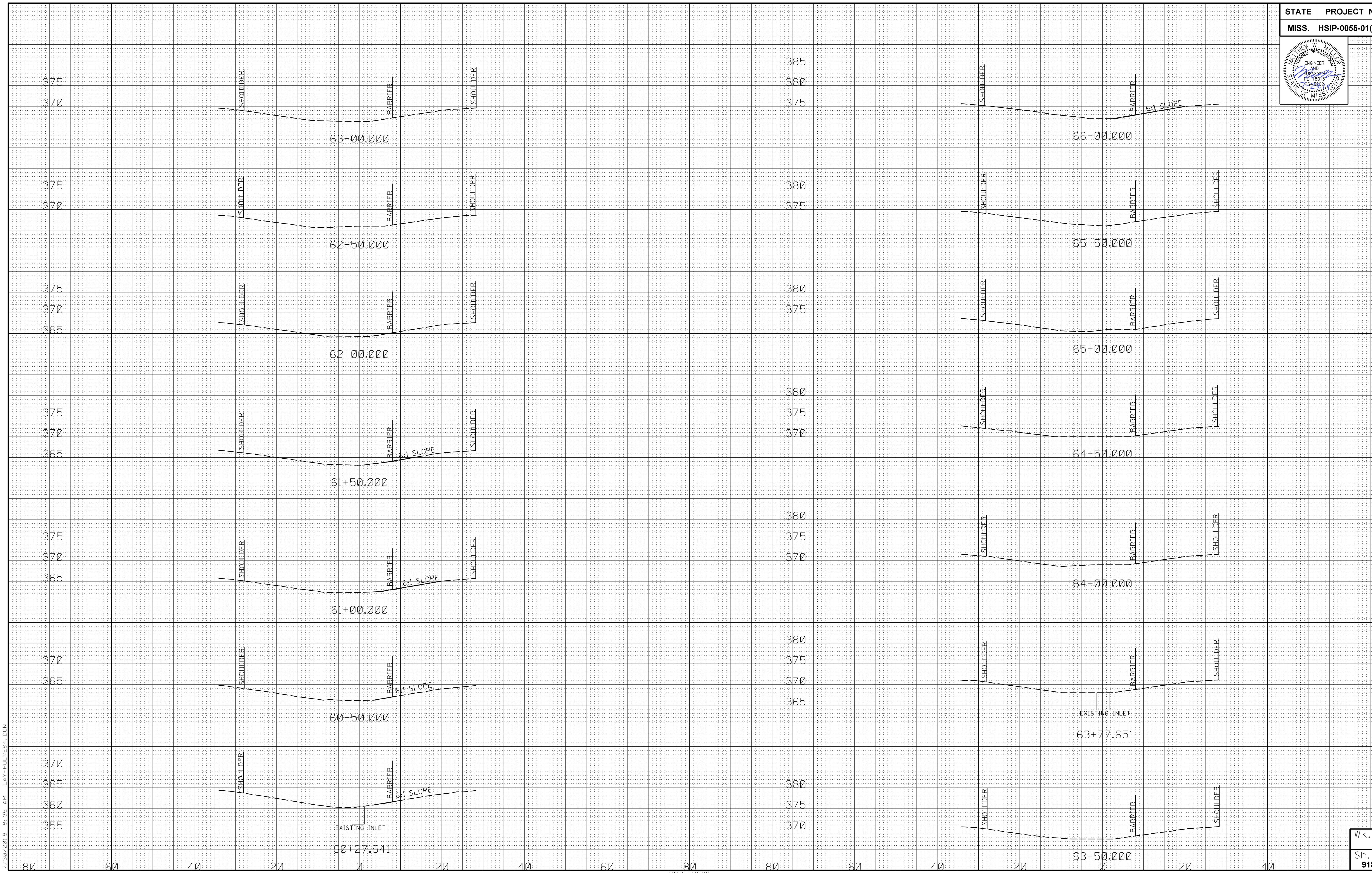
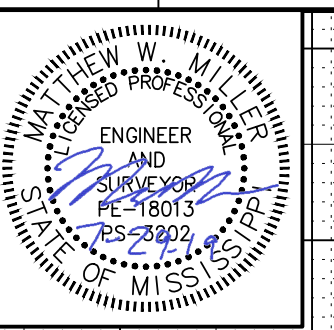

7/30/2019 8:35 AM LAY-HOLMES4.DGN

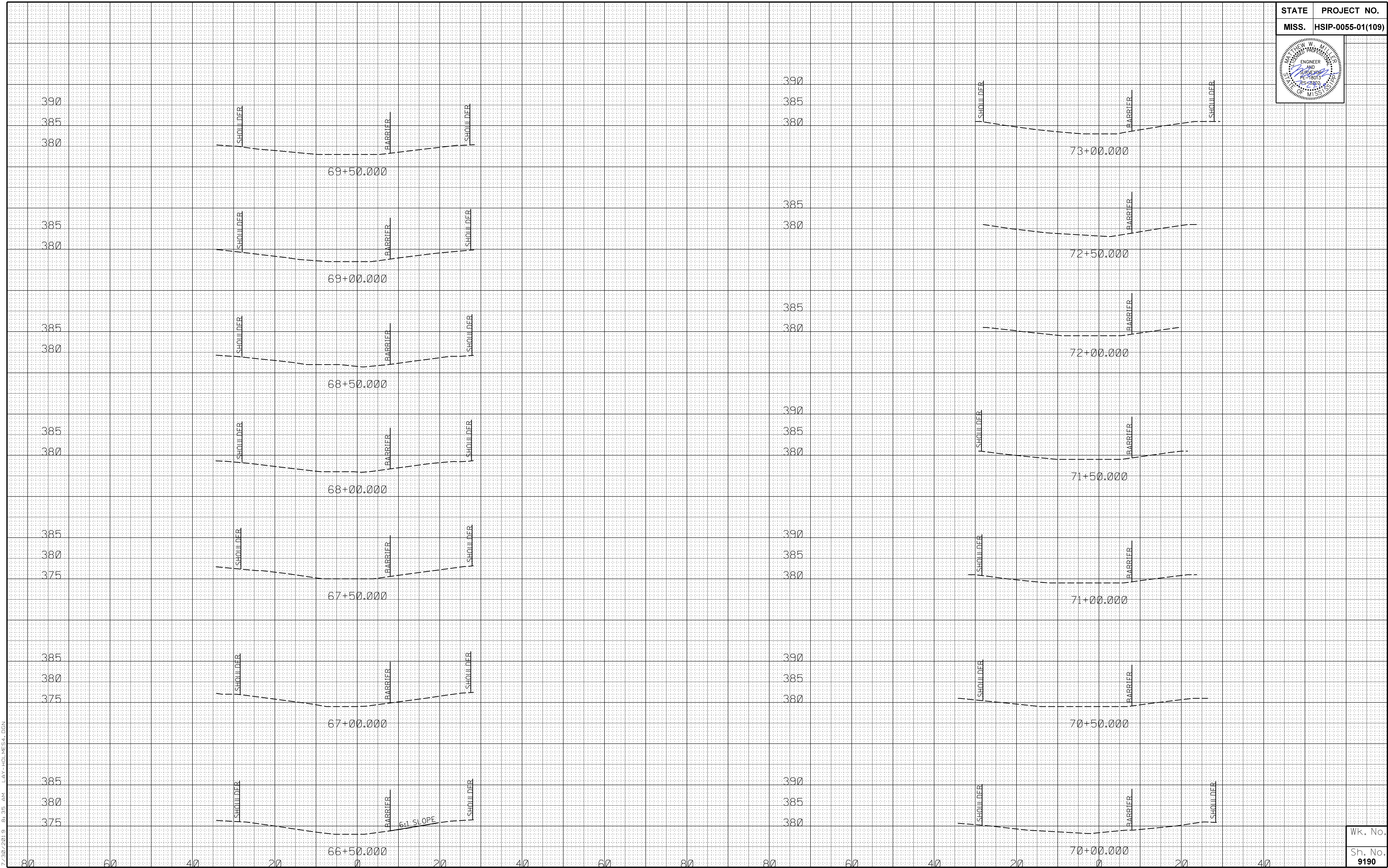
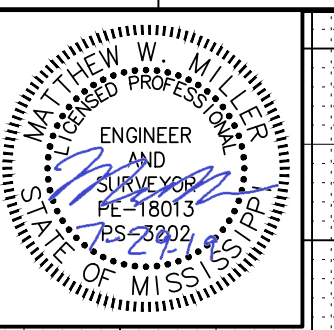

7/30/2019 8:35 AM LAY-HOLMES4.DGN

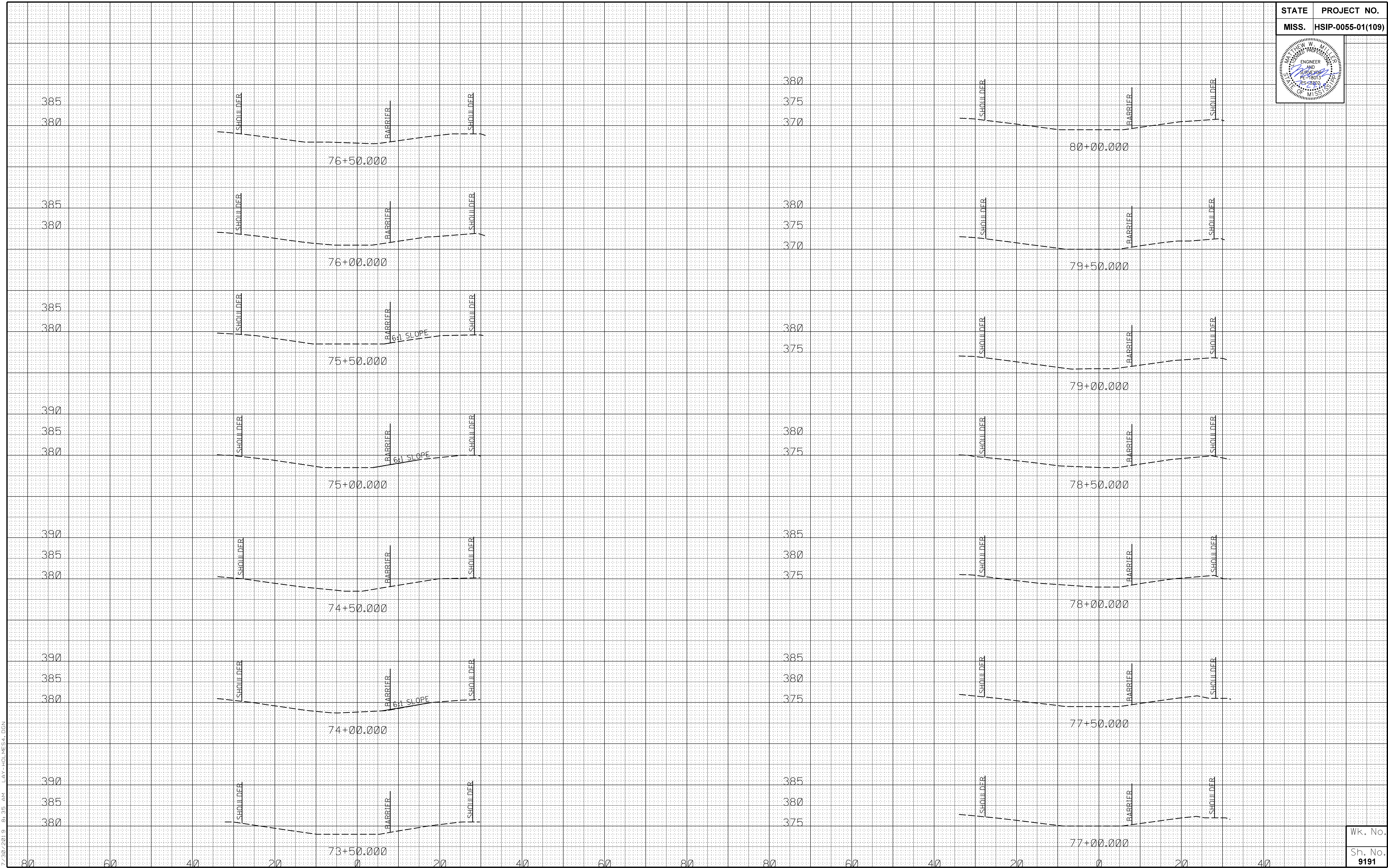
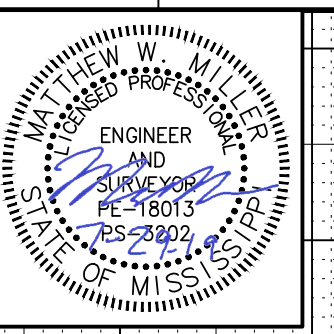

7/30/2019 8:35 AM LAY-HOLMES4.DGN

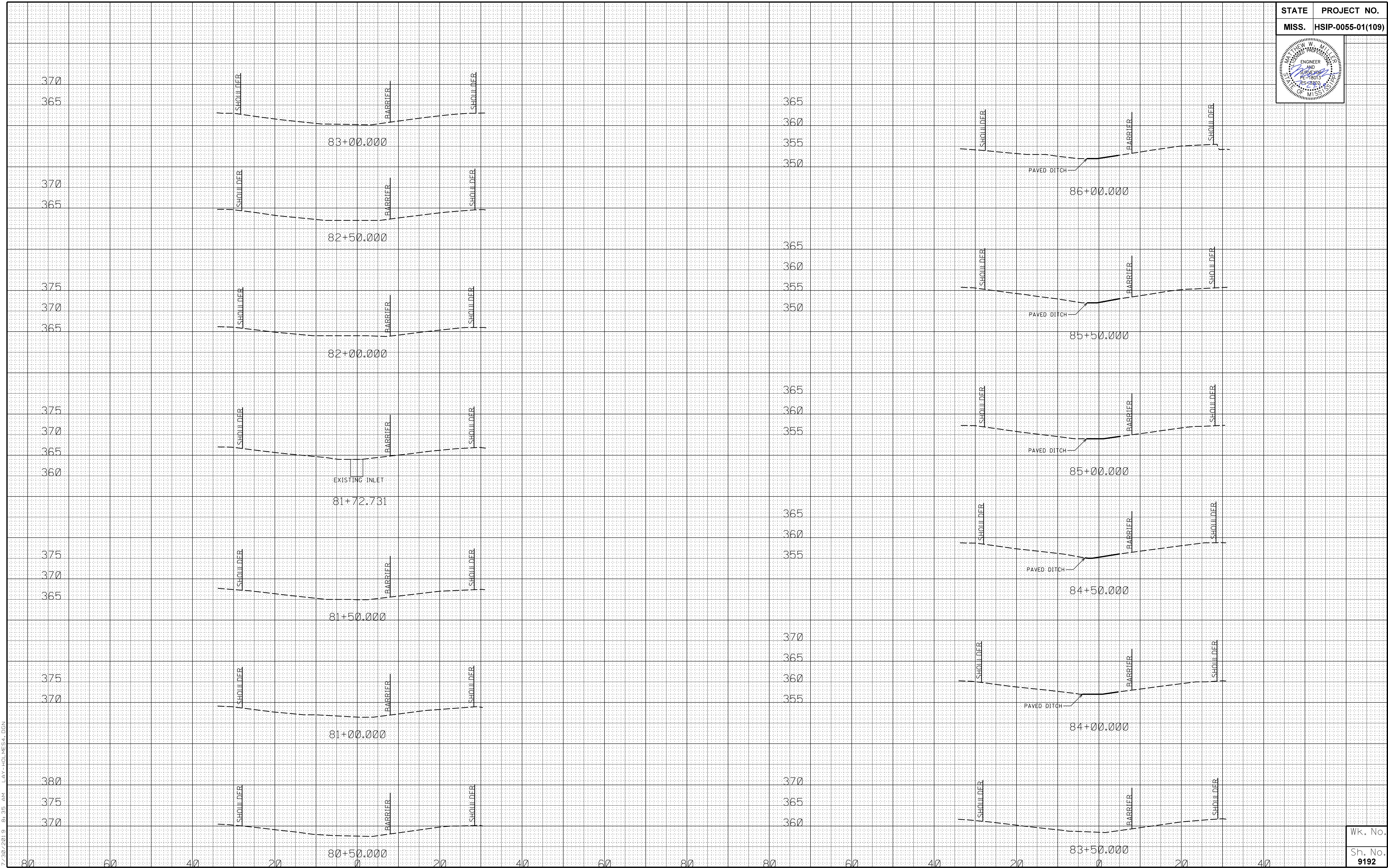
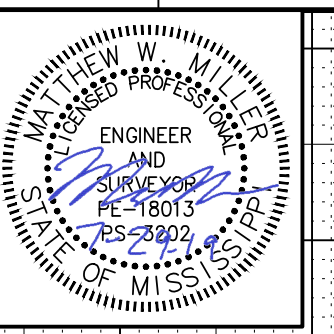

7/30/2019 8:35 AM LAY-HOLMES4.DGN

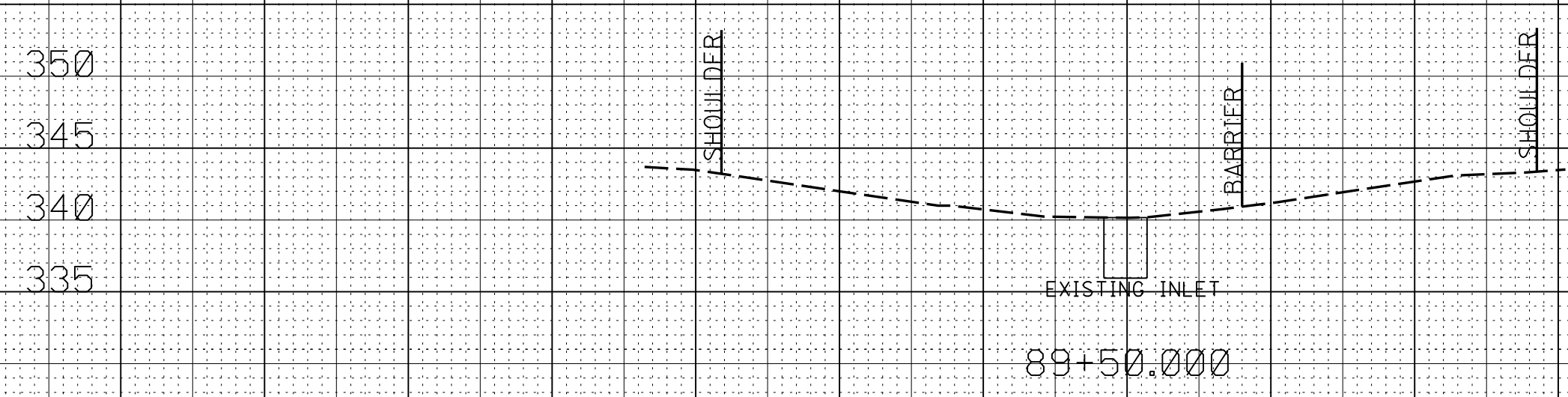
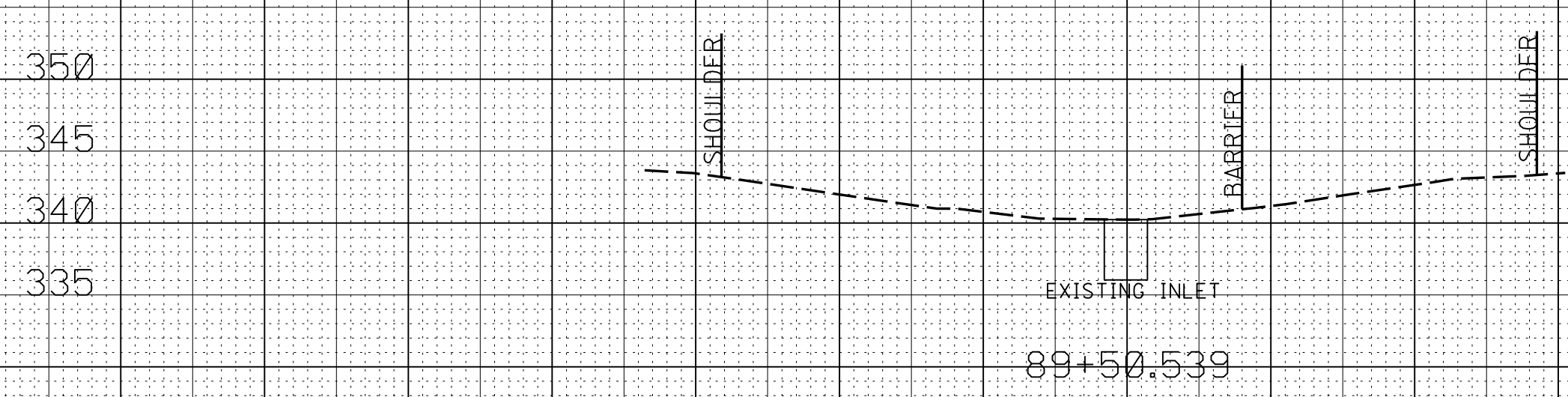
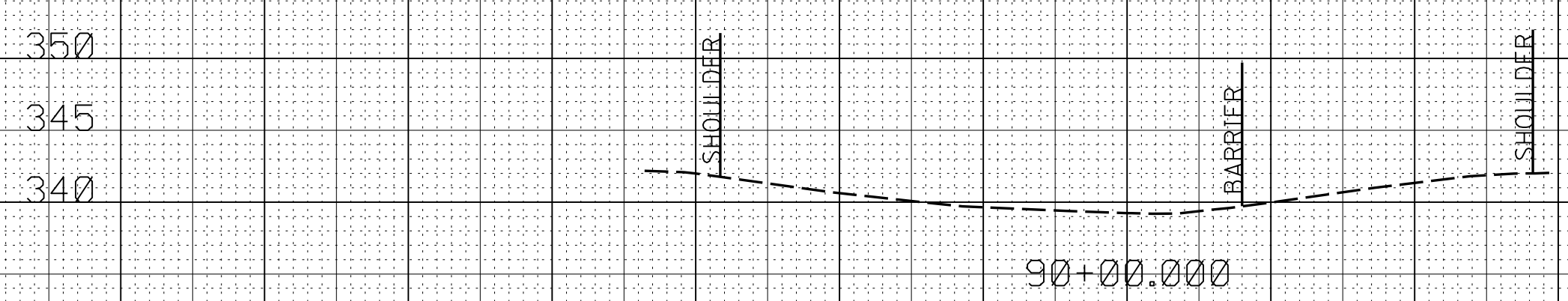
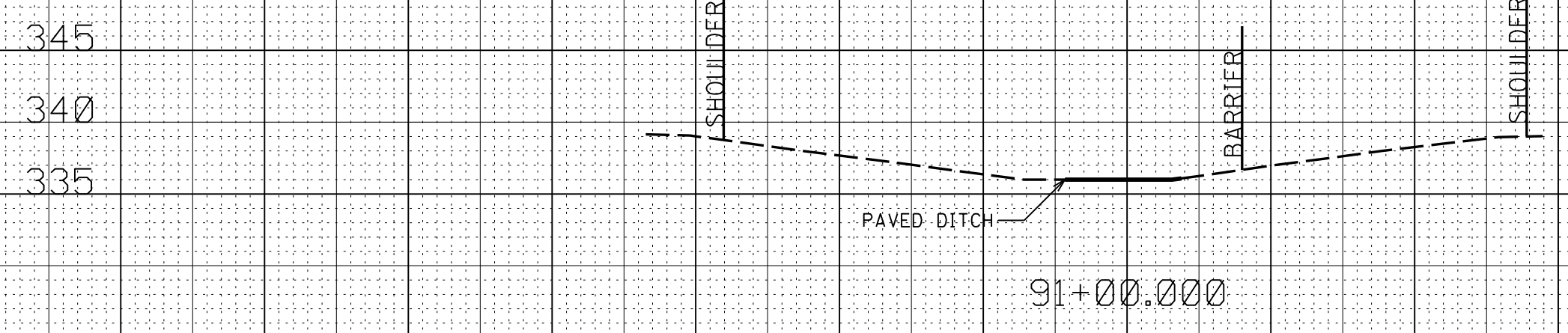
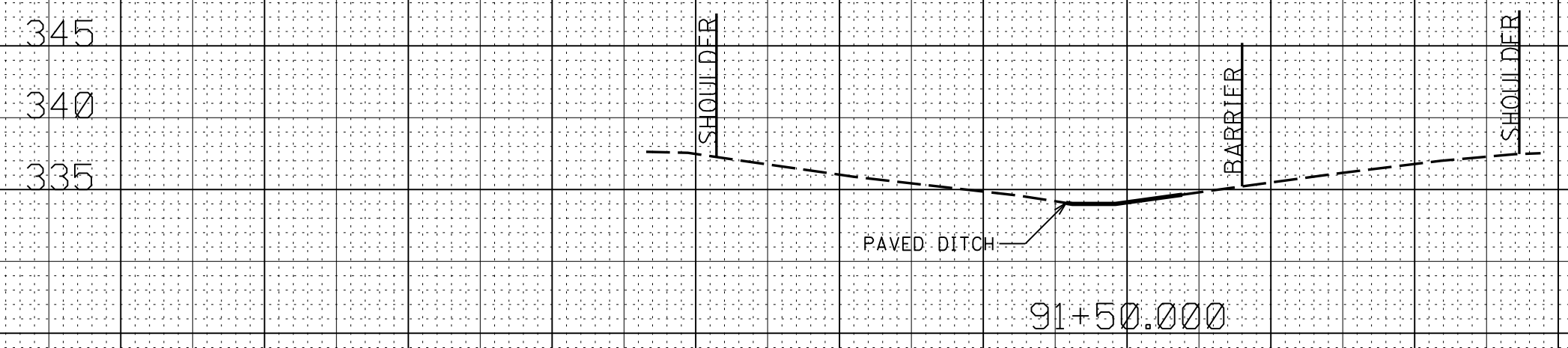
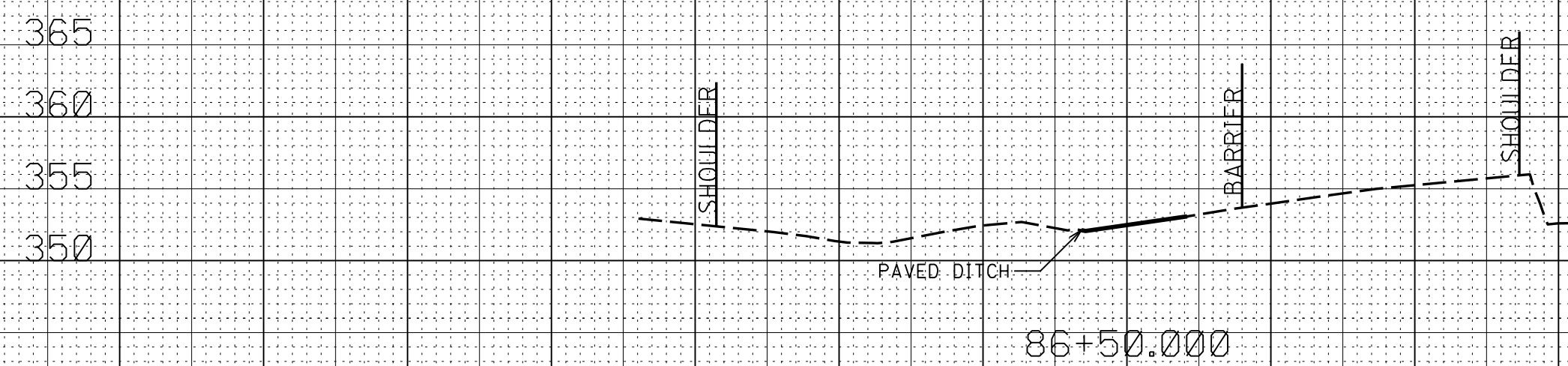
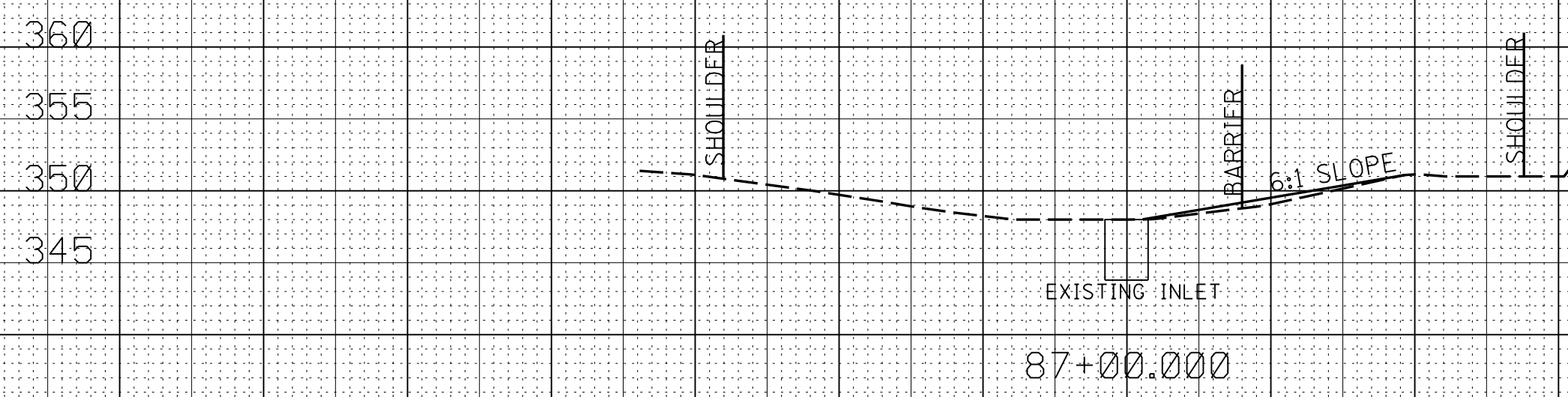
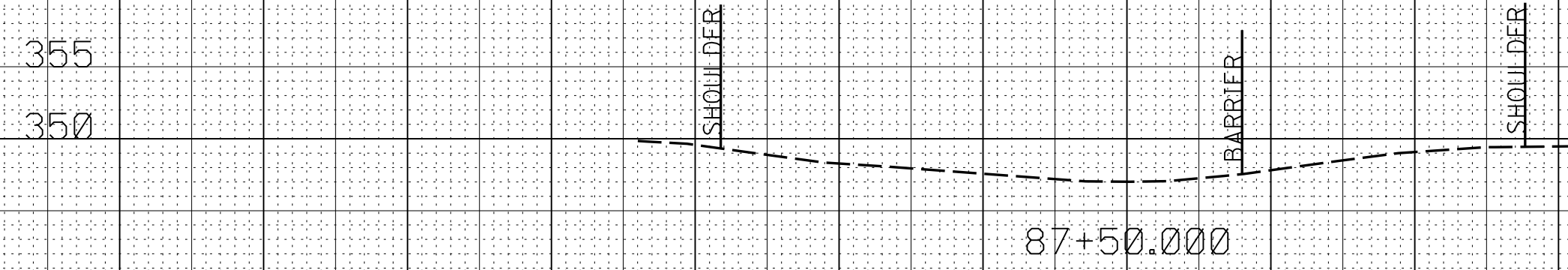
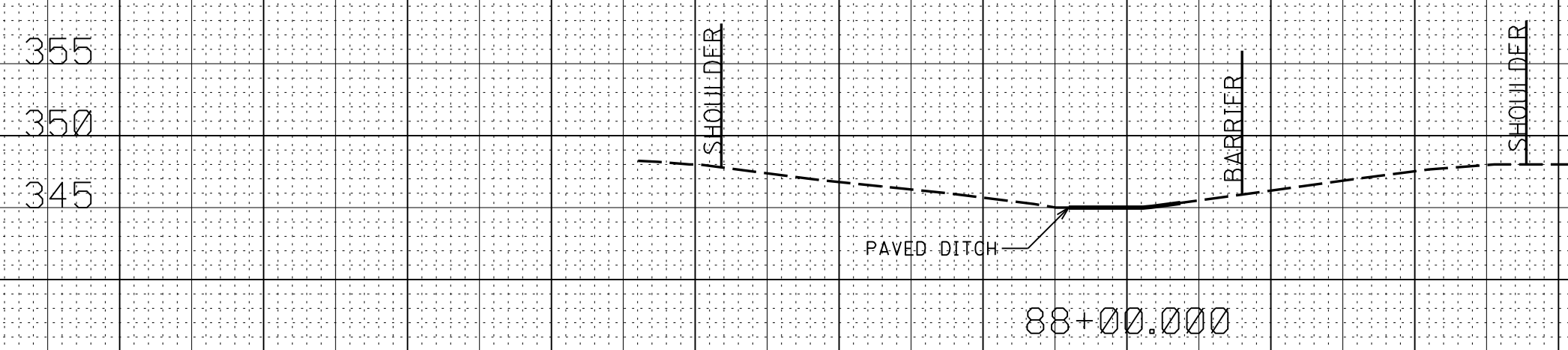
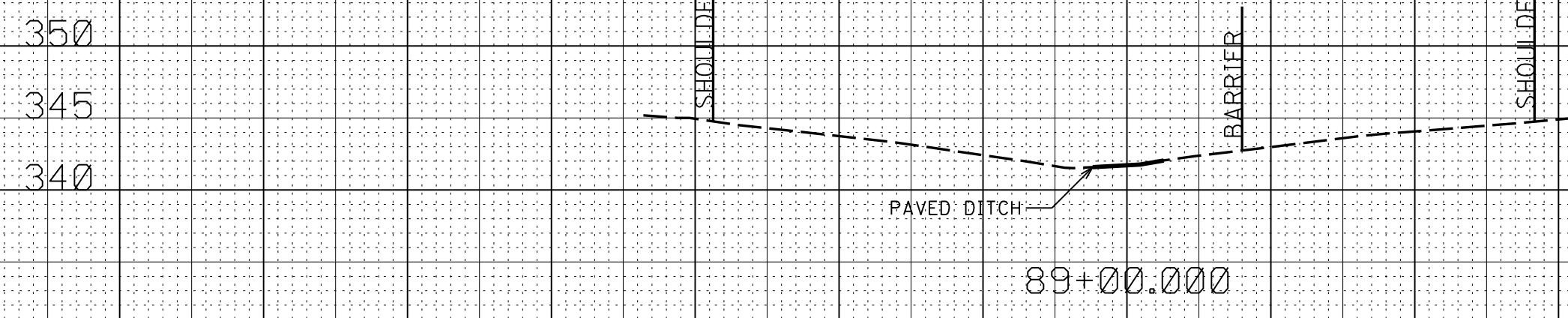
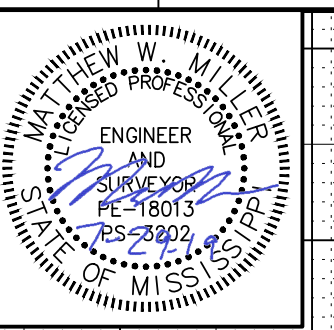

7/30/2019 8:35 AM LAY-HOLMES4.DGN

80 60 40 20 0 20 40 60 80 80 60 40 20 0 20 40

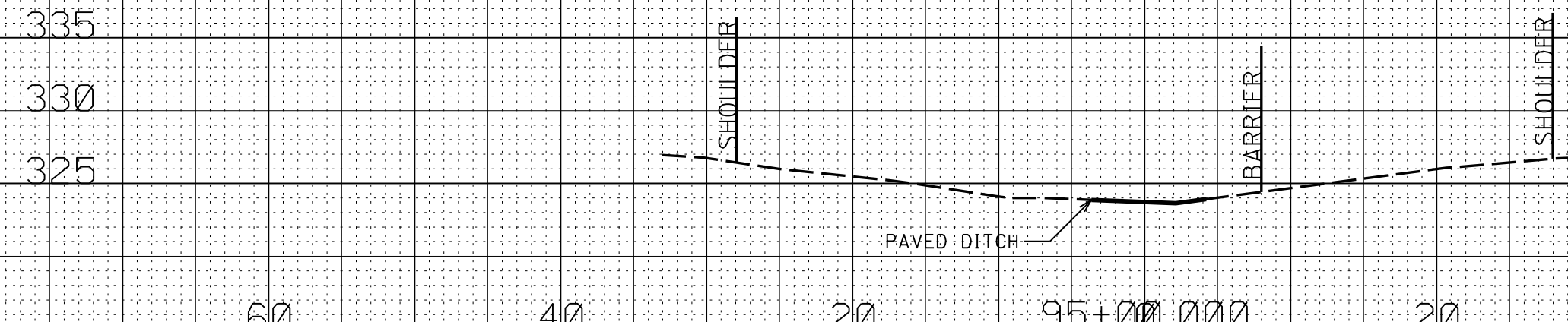
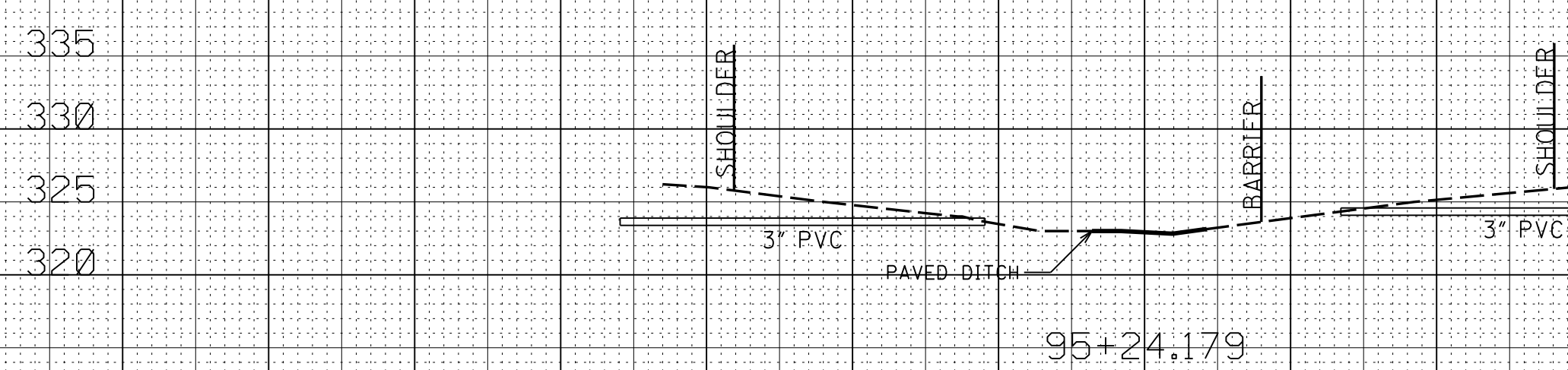
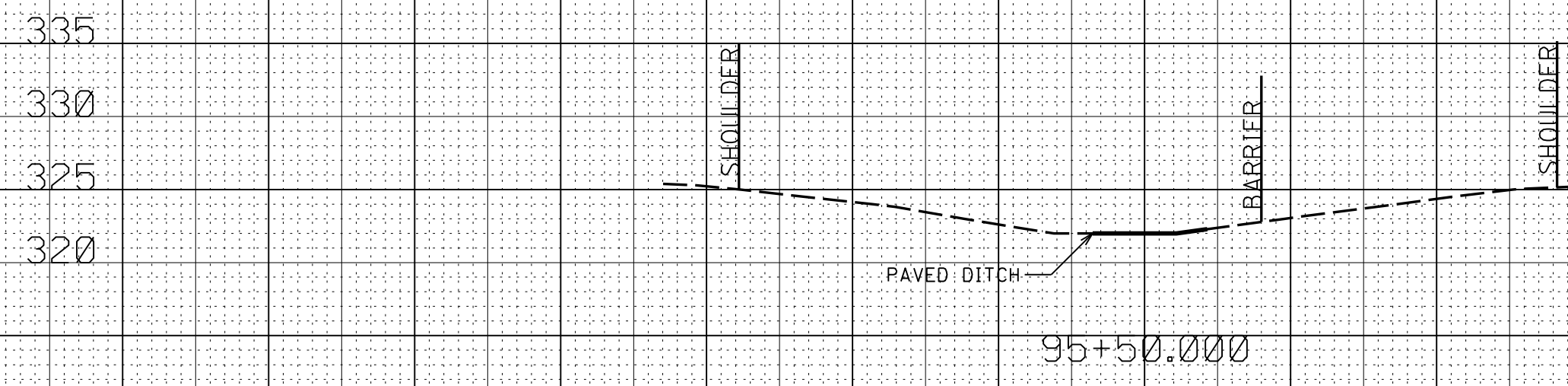
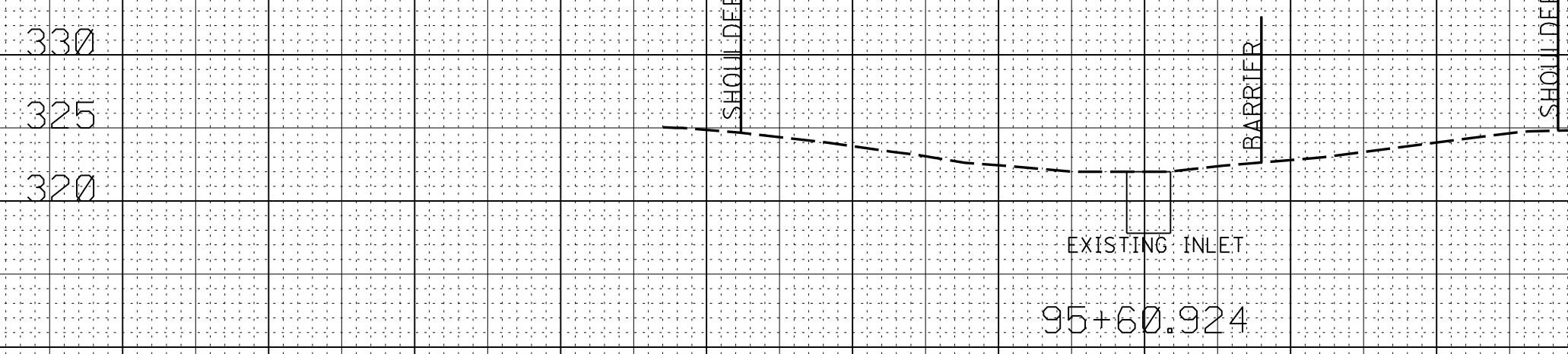
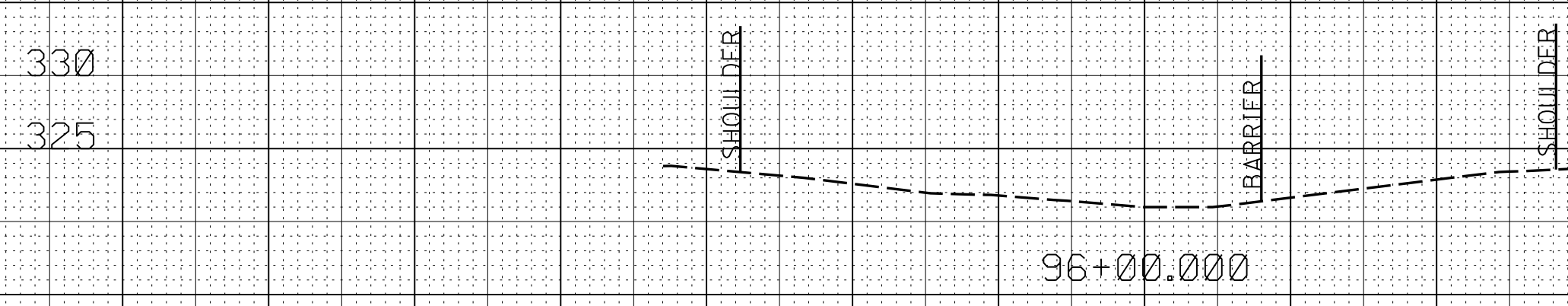
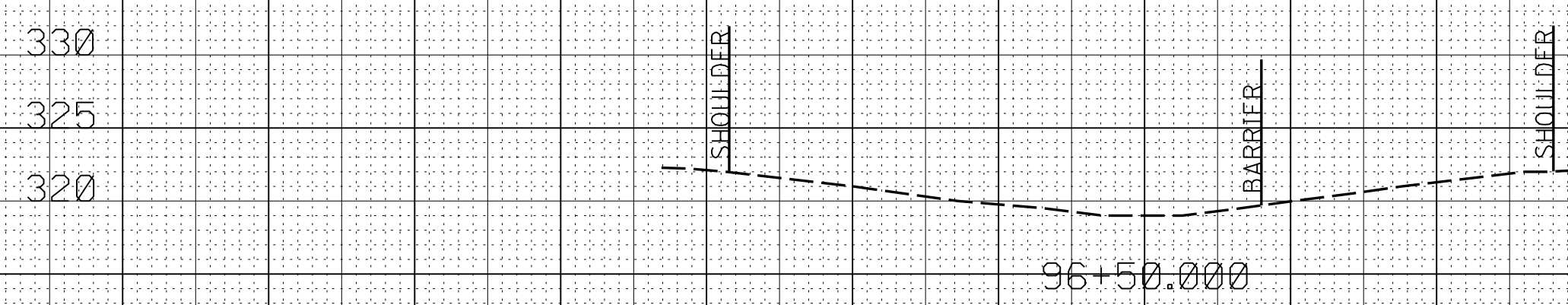
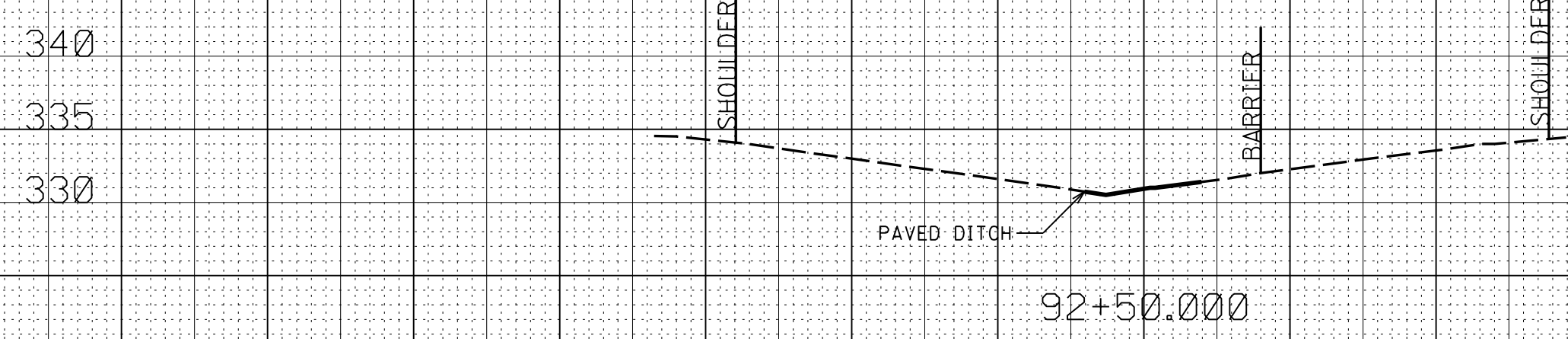
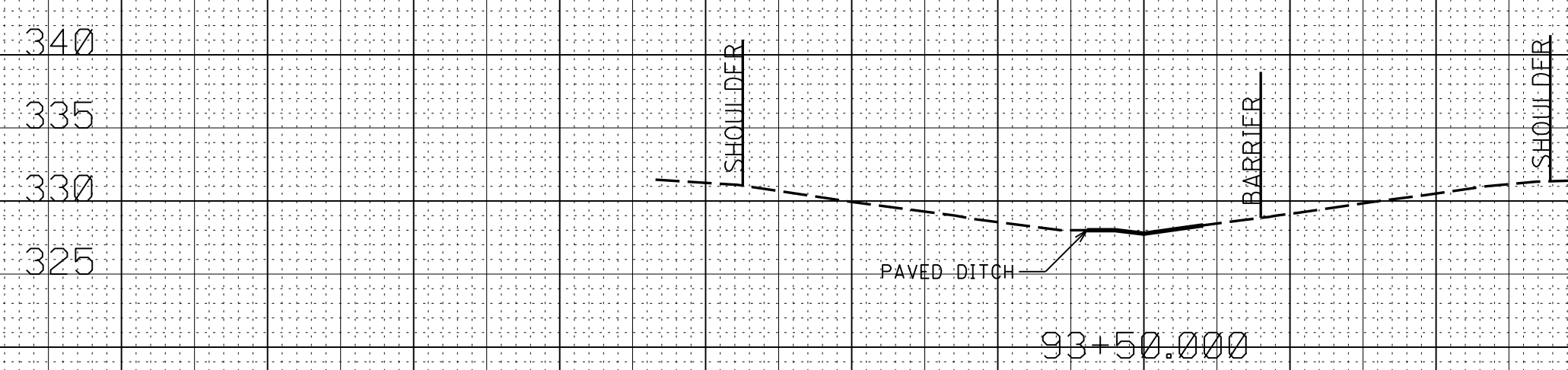
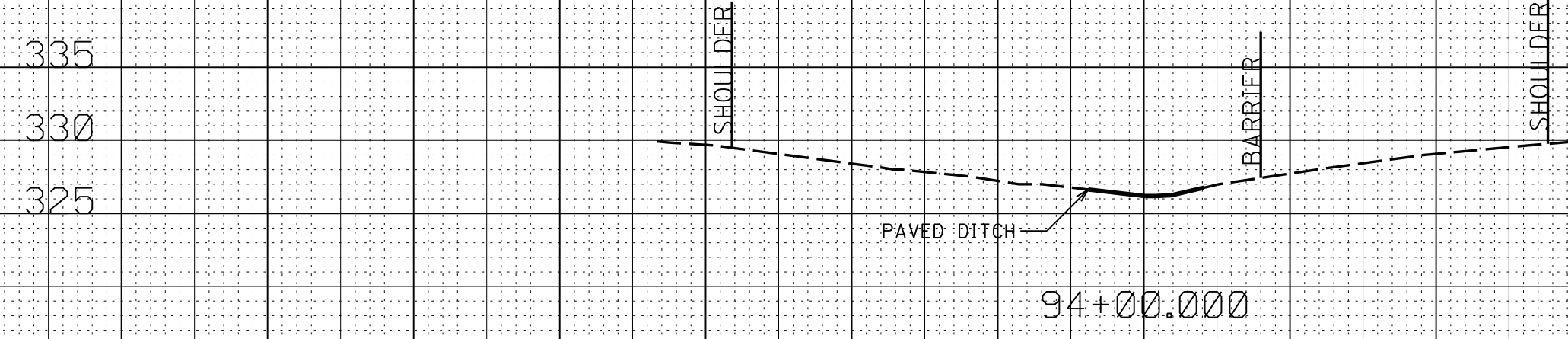
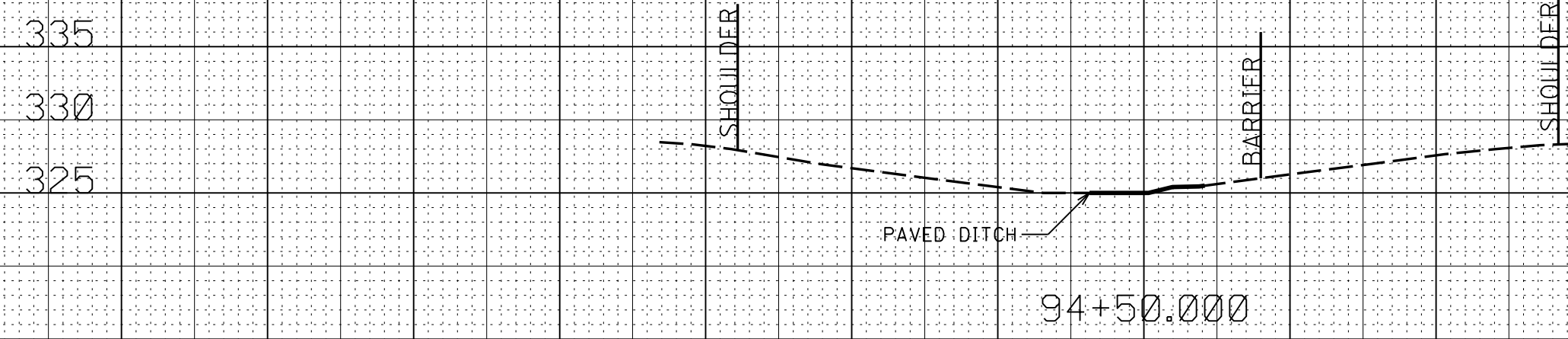
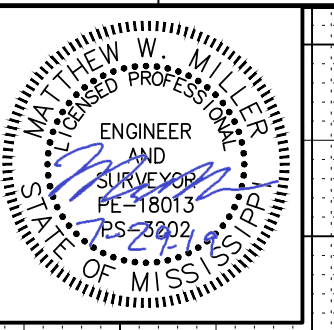

7/30/2019 8:35 AM LAY-HOLME.S4.DGN

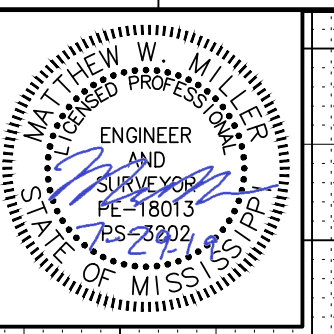

325
320
315
310
325
320
315
320
315
320
315
320
315
325
320
315
330
325
320
315

320
315
310
305
320
315
310
305
320
315
310
305
320
315
310
305
325
320
315
310

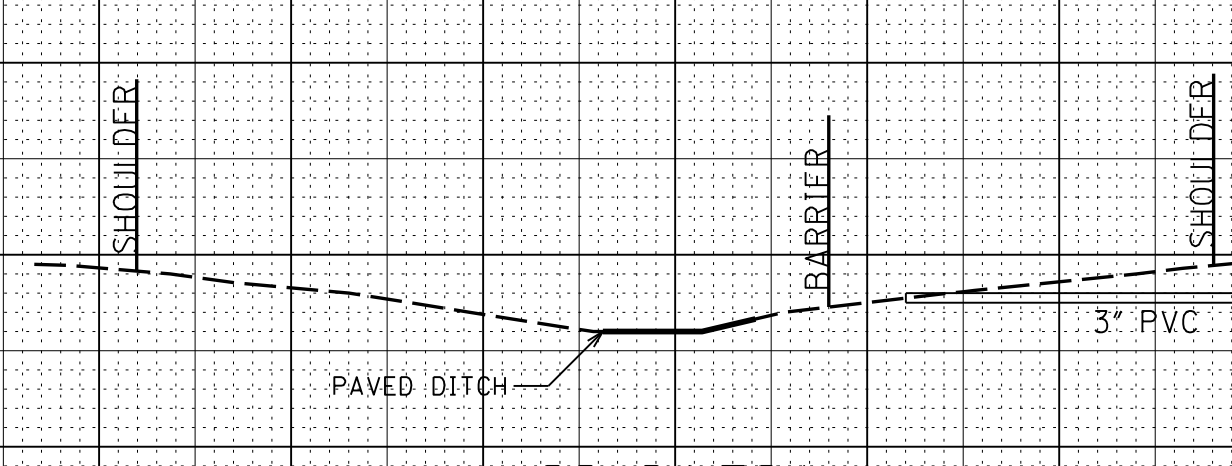
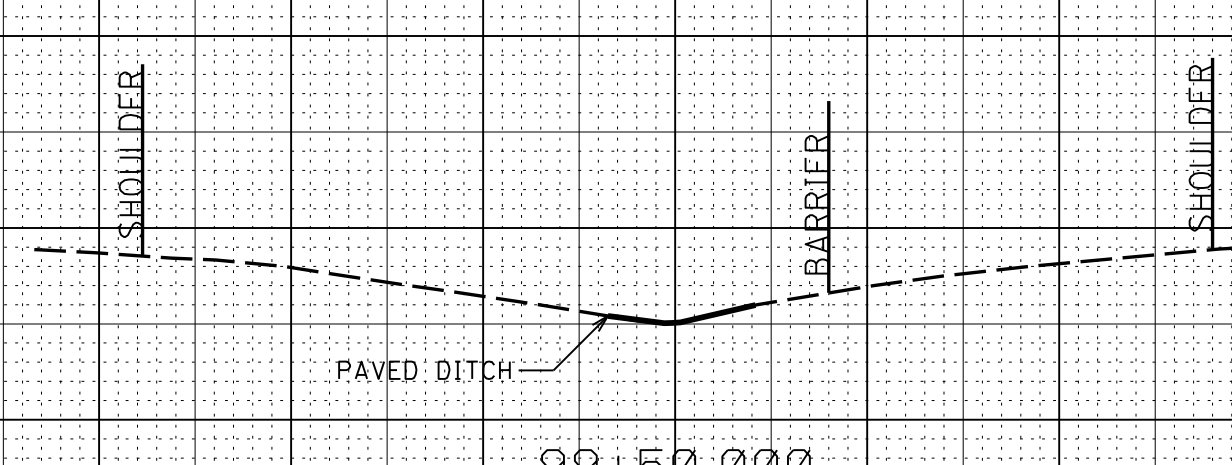
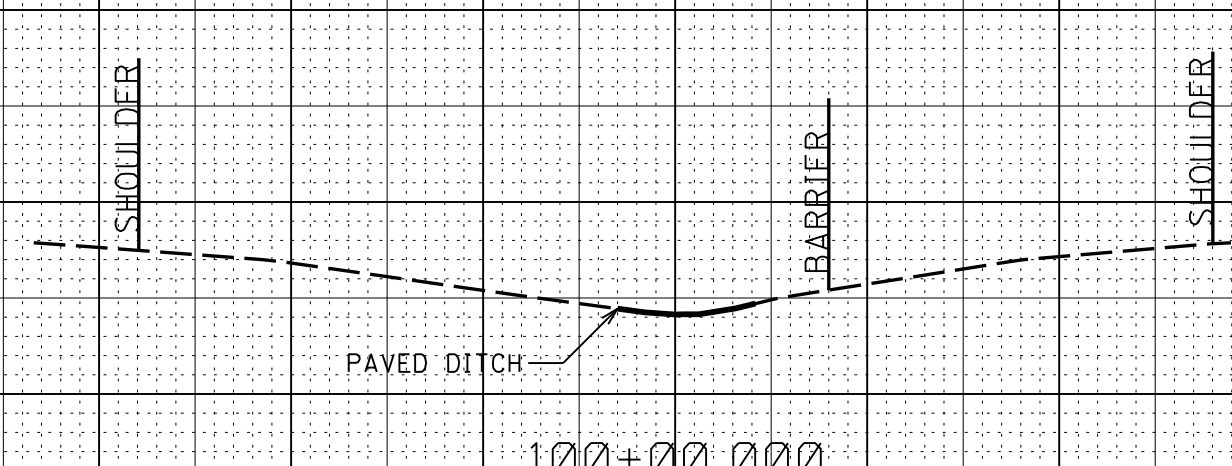
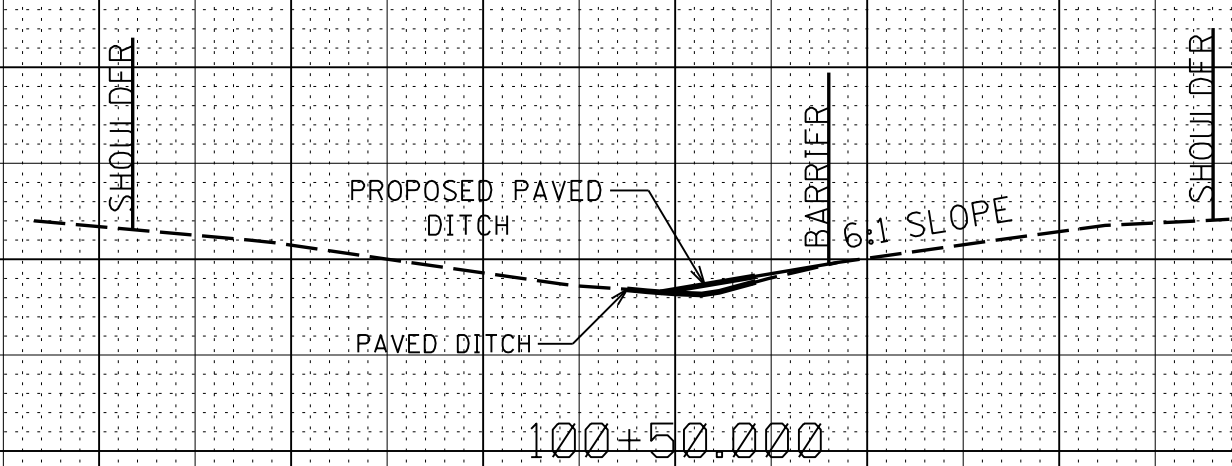
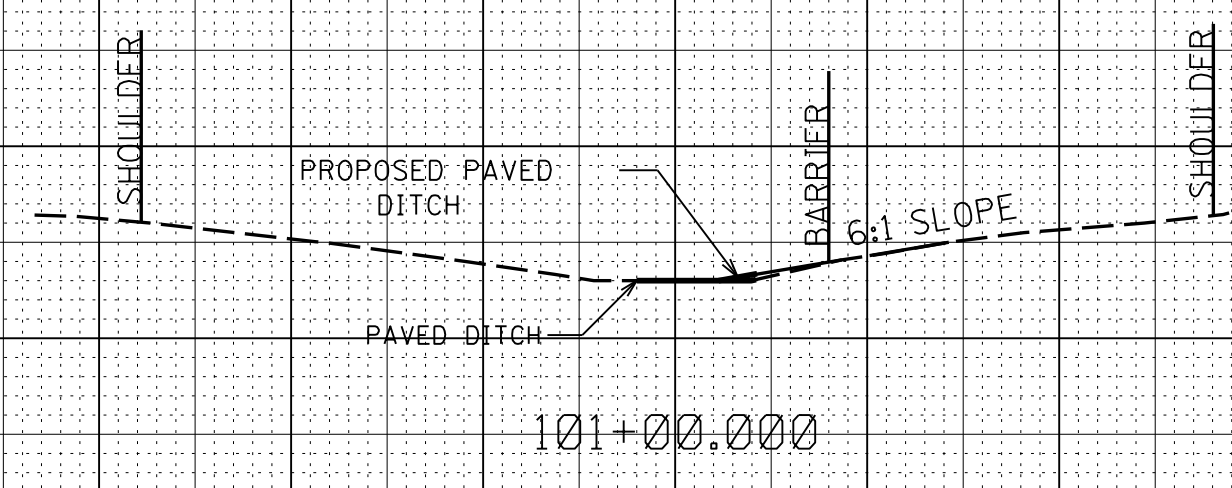
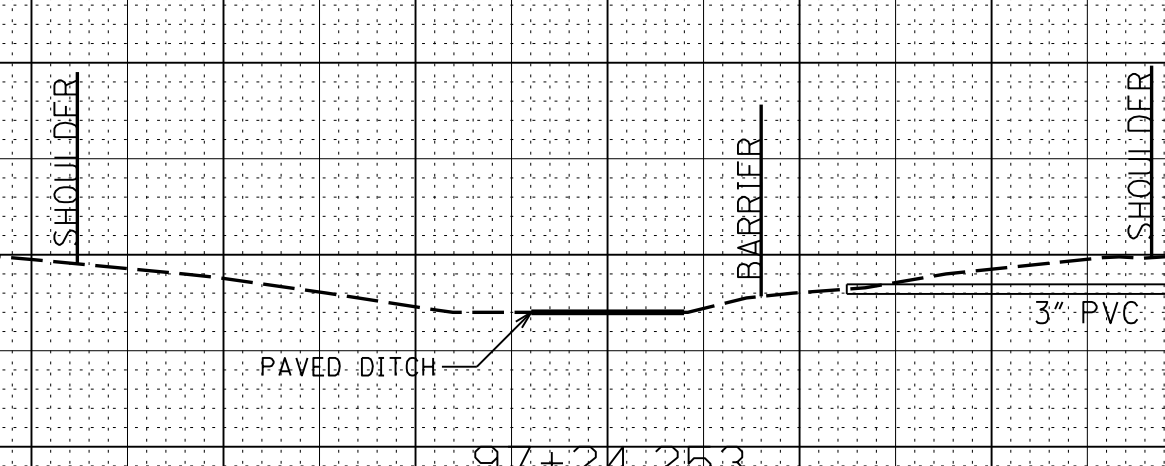
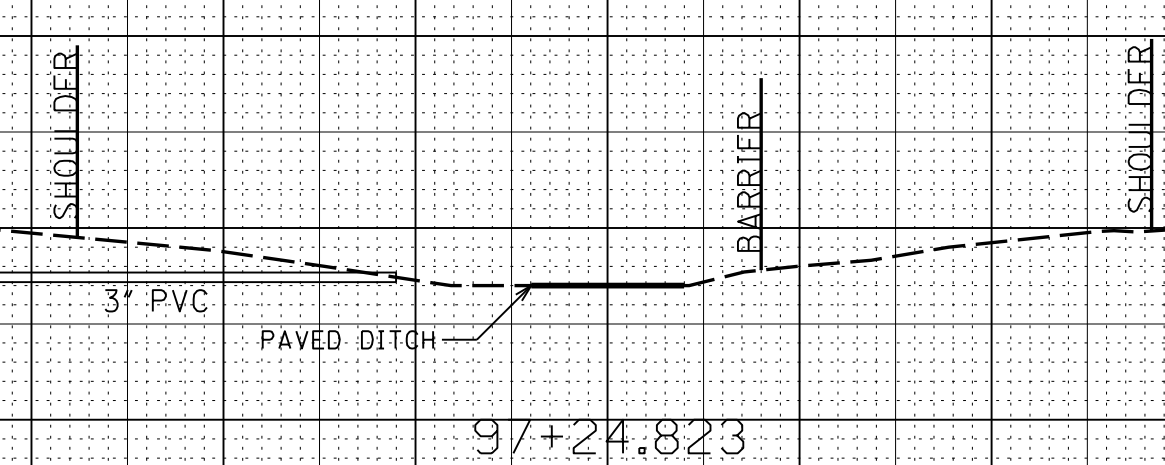
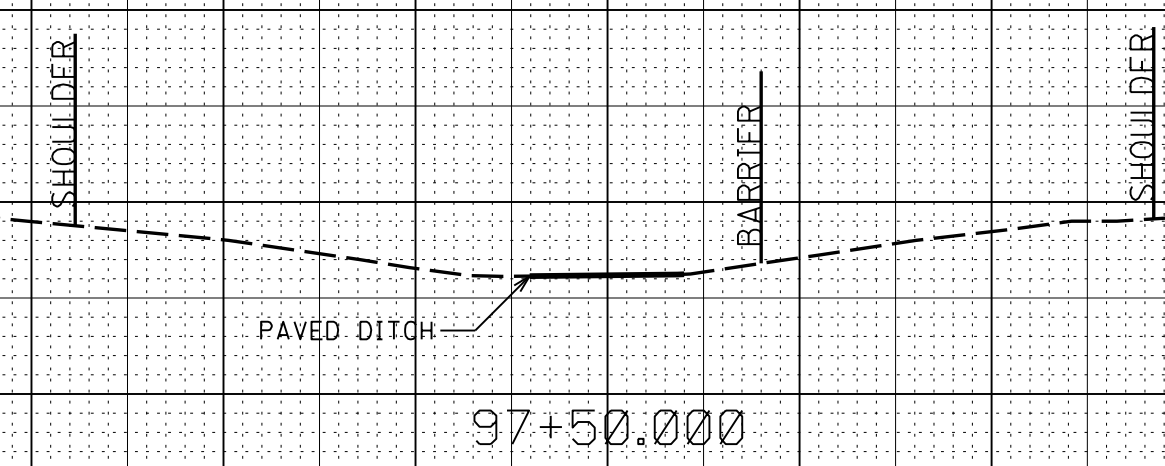
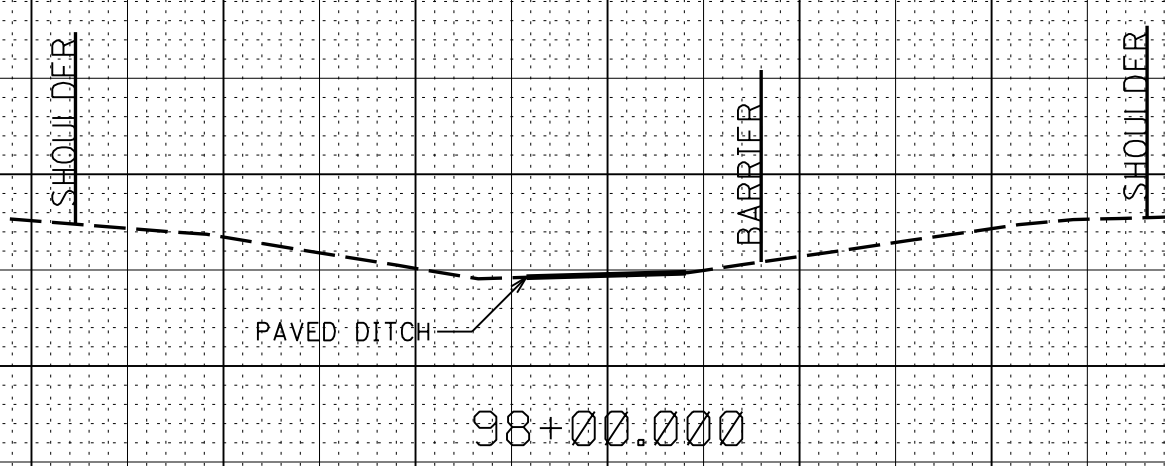
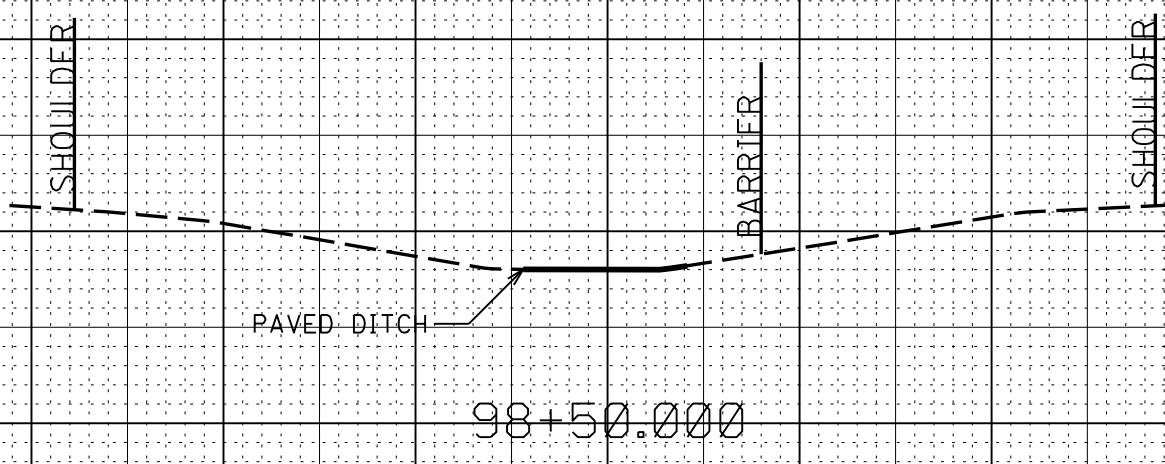

7/30/2019 8:35 AM LAY-HOLMES4.DGN

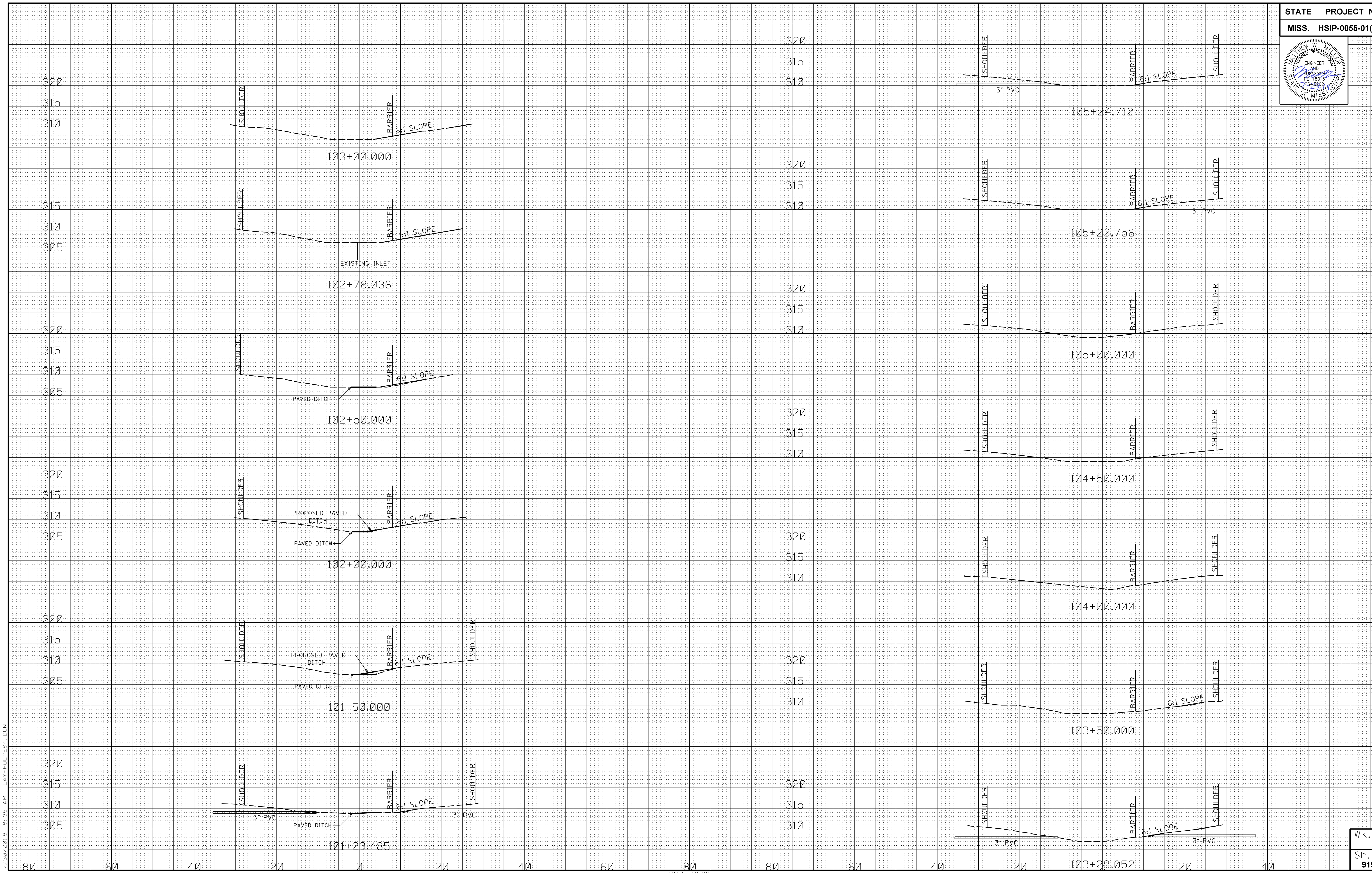
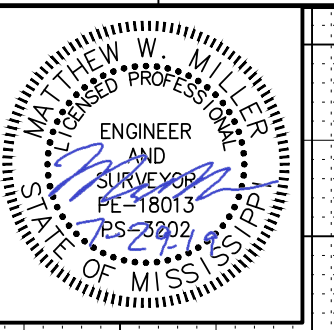

7/30/2019 8:35 AM LAY-HOLMES4.DGN

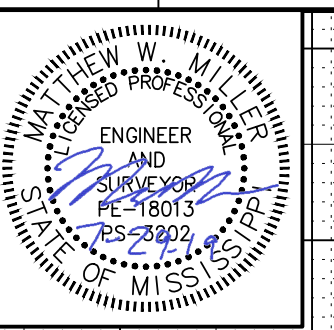

325
320
315
325
320
315
325
320
315
325
320
315
320
315
320
315
320
315
310

330
325
320
330
325
320
330
325
320
325
320
315
325
320
315

107+50.000

107+23.019

107+22.063

107+00.000

106+50.000

106+00.000

105+50.000

110+00.000

109+50.000

109+24.090

109+22.294

109+00.000

108+50.000

108+00.000

SHOULDER

BARRIER

SHOULDER

SHOULDER

BARRIER

SHOULDER

SHOULDER

BARRIER

SHOULDER

SHOULDER

BARRIER

SHOULDER

SHOULDER

BARRIER

SHOULDER

SHOULDER

BARRIER

SHOULDER

SHOULDER

BARRIER

SHOULDER

SHOULDER

BARRIER

SHOULDER

SHOULDER

BARRIER

SHOULDER

SHOULDER

BARRIER

SHOULDER

SHOULDER

BARRIER

SHOULDER

SHOULDER

BARRIER

SHOULDER

SHOULDER

BARRIER

SHOULDER

SHOULDER

BARRIER

SHOULDER

3" PVC

3" PVC

3" PVC

3" PVC

6:1 SLOPE

6:1 SLOPE

6:1 SLOPE

6:1 SLOPE

6:1 SLOPE

6:1 SLOPE

7/30/2019 8:35 AM LAY-HOLMES4.DGN

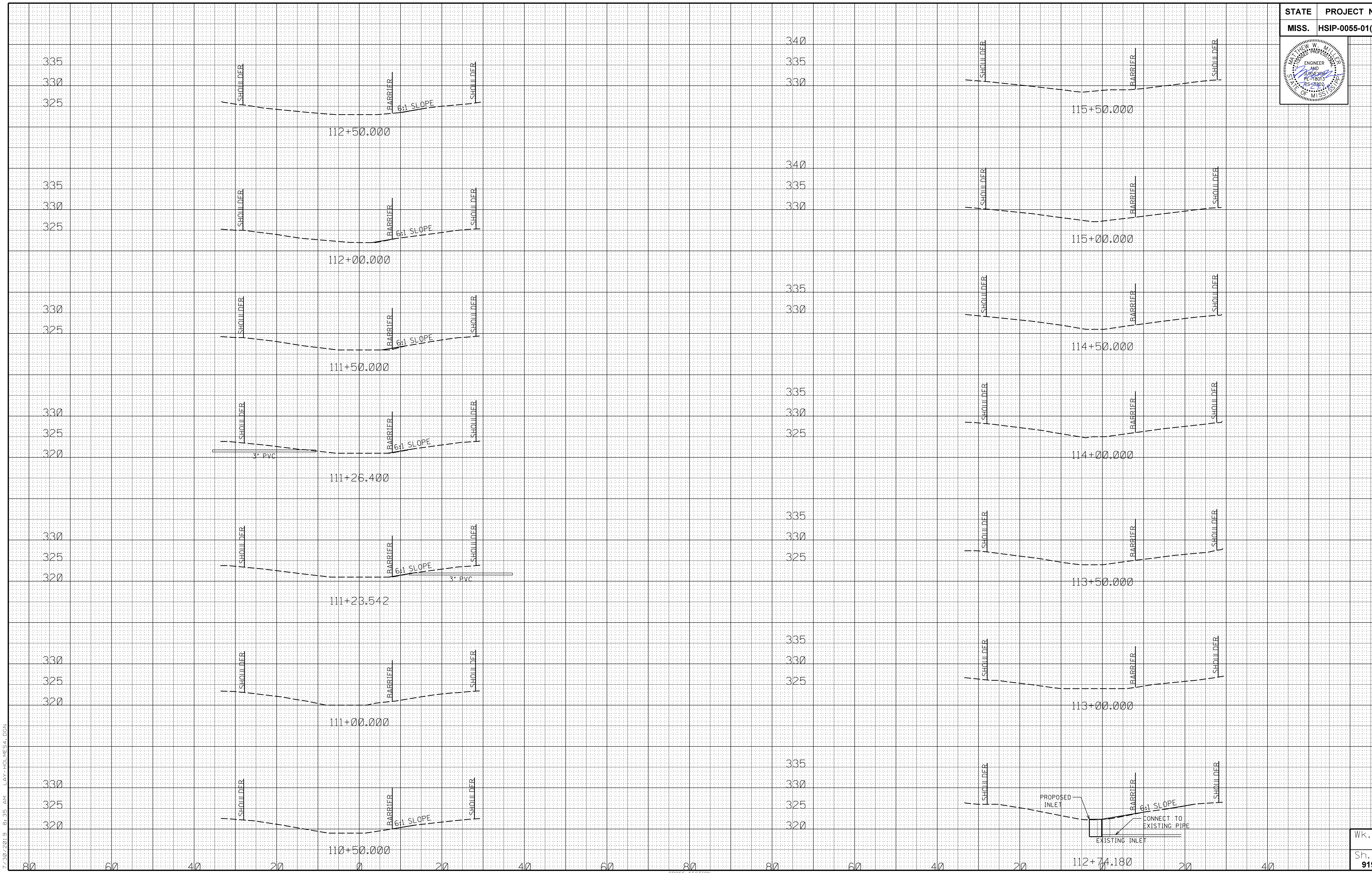
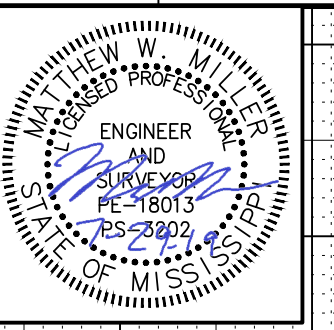

7/30/2019 8:35 AM LAY-HOLME.S4.DGN

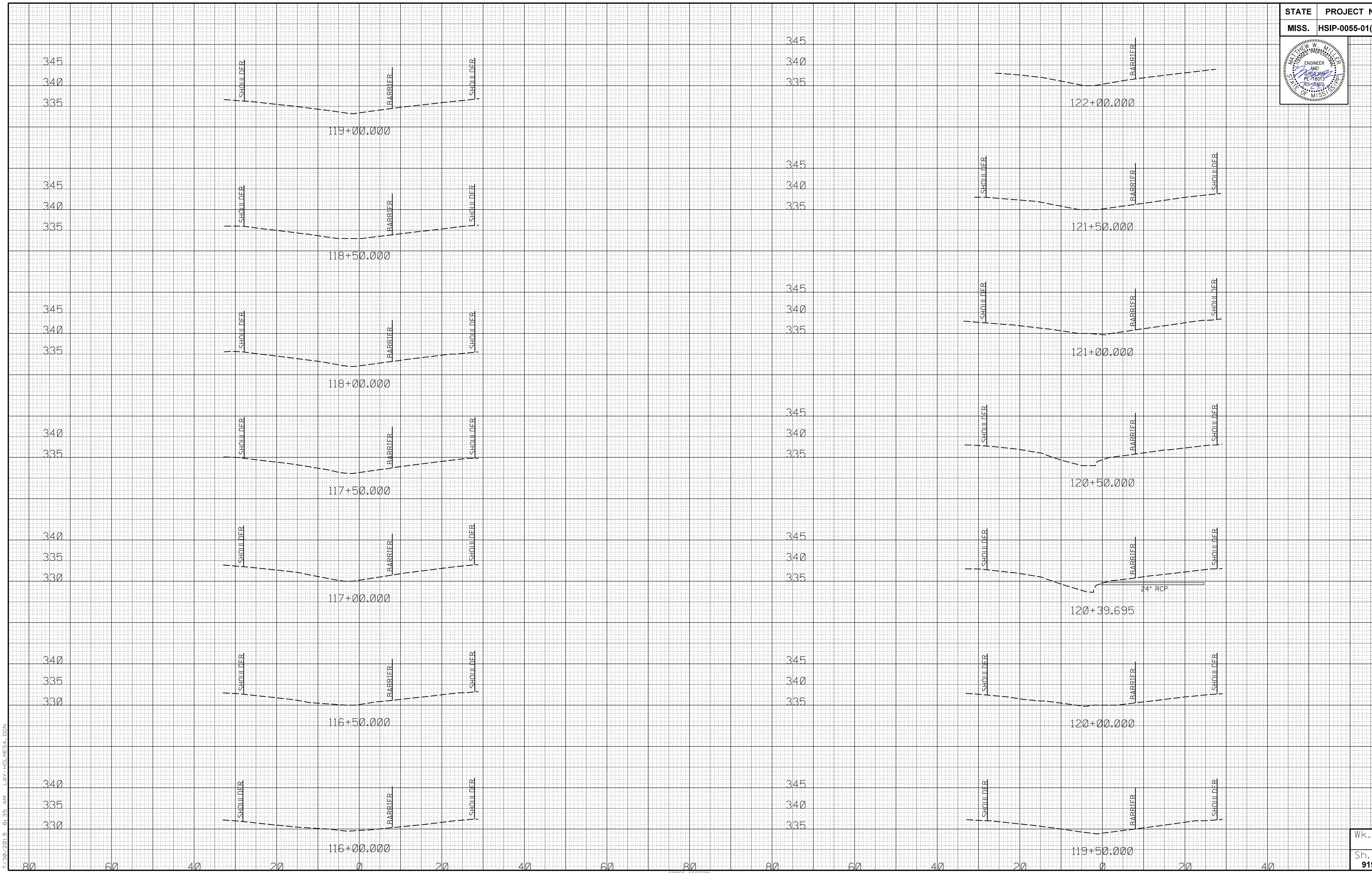
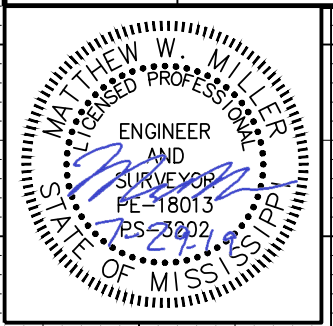

7/30/2019 8:35 AM LAY-HOLMES4.DGN

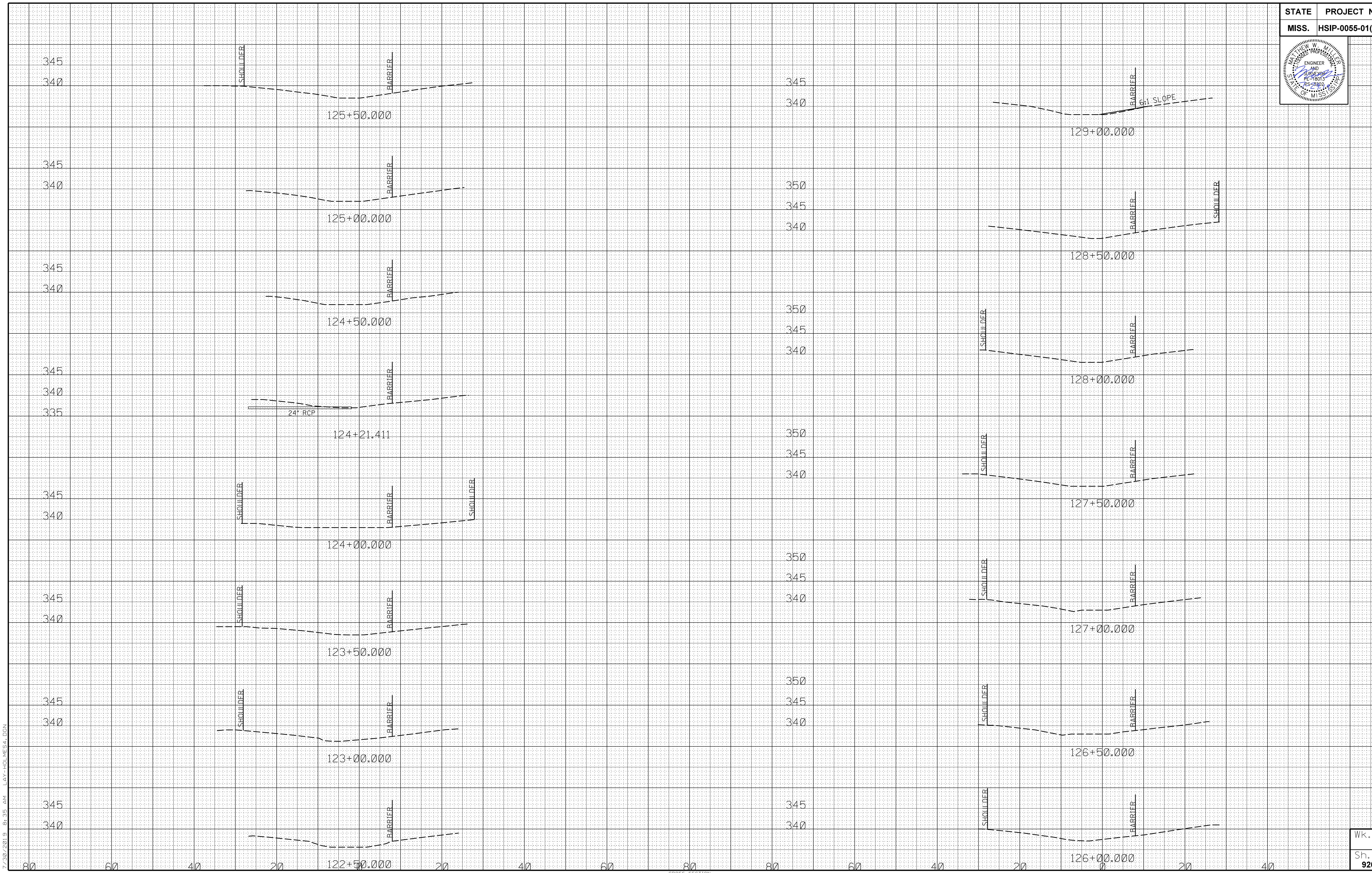
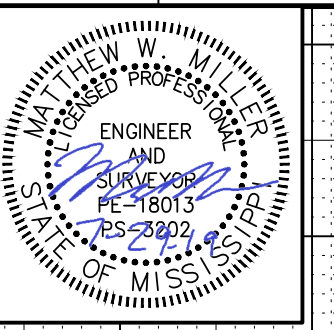

7/30/2019 8:35 AM LAY-HOLMES4.DGN

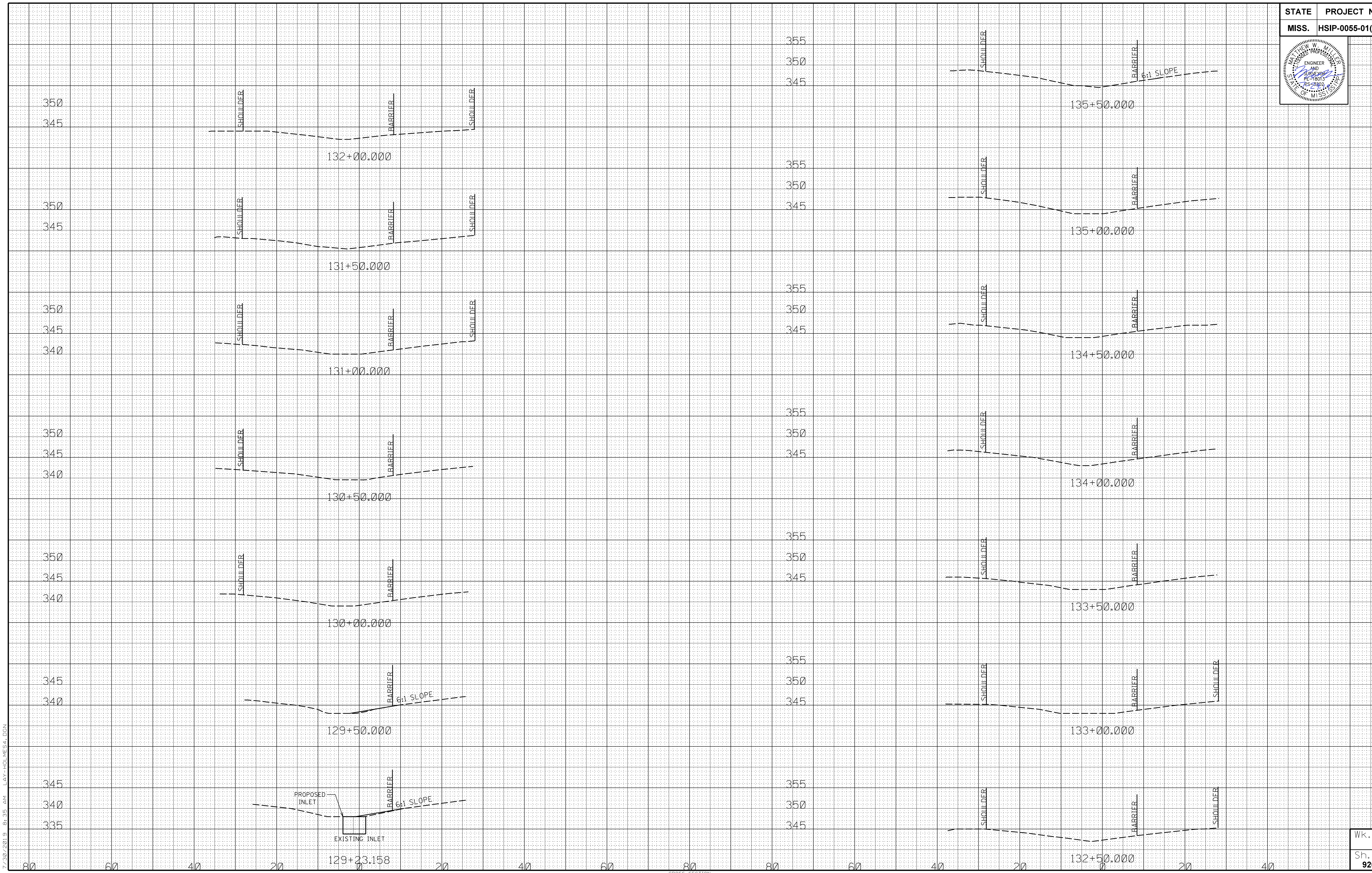
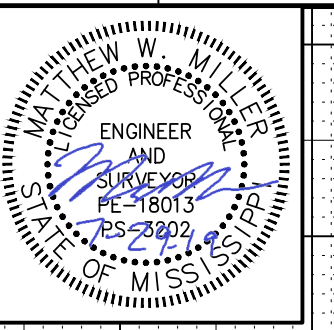

7/30/2019 8:35 AM LAY-HOLMES4.DGN

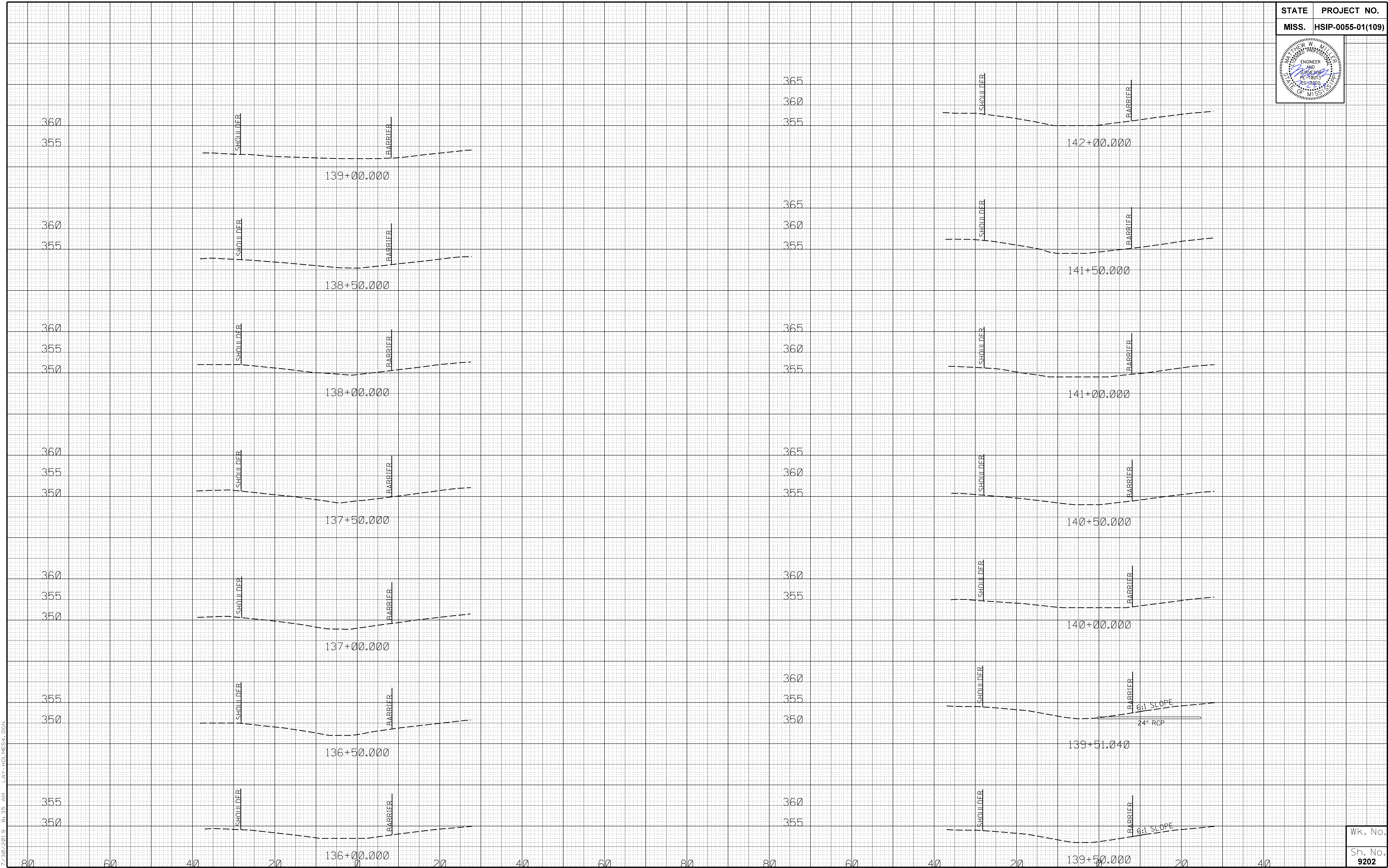
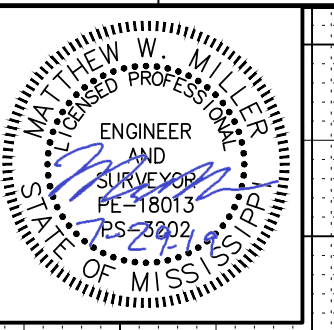

7/30/2019 8:35 AM LAY-HOLMES4.DGN

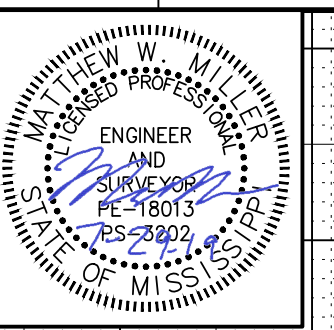

370
365
360
370
365
360
370
365
360
370
365
360
370
365
360
365
360
365
360

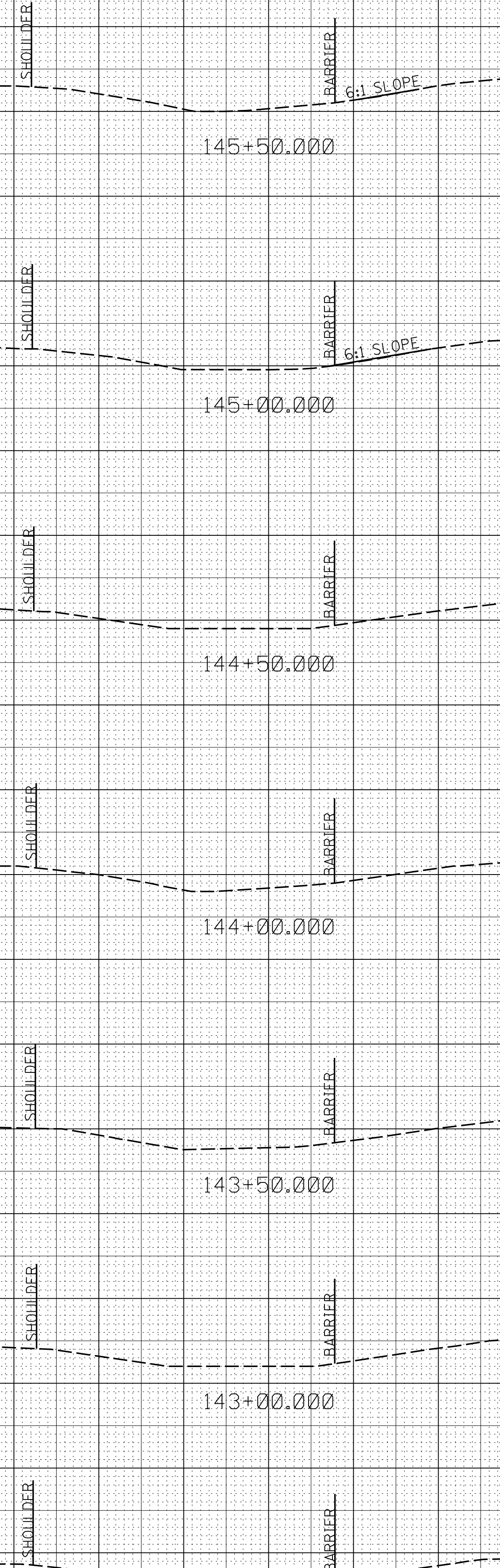

375
370
365
375
370
365
375
370
365
375
370
365
370
365
365
370
365
370
365

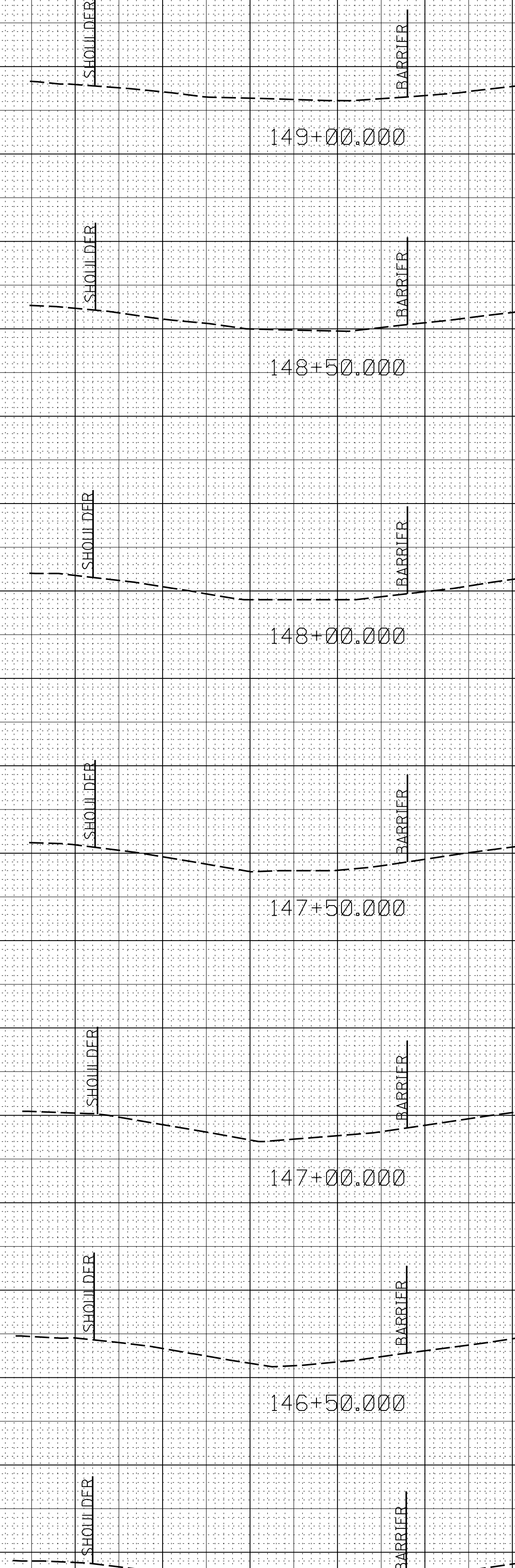

80 60 40 20 142+50.000 20 40 60 80 80 60 40 20 146+00.000 20 40

7/30/2019 8:35 AM LAY-HOLMES4.DGN

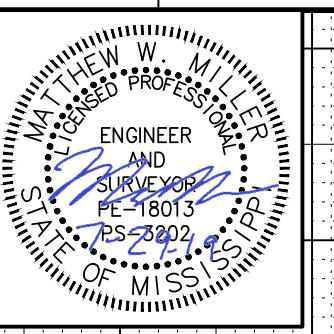

380
375
370
380
375
370
380
375
370
375
370
375
370
375
370
375
370
365
360

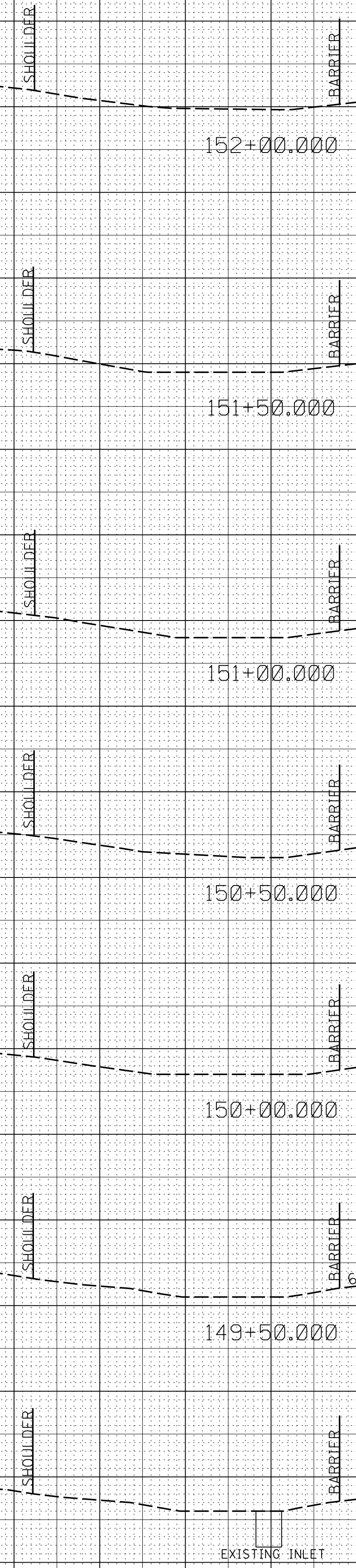

6:1 SLOPE

385
380
375
380
375
370
380
375
370
380
375
370
380
375
370
380
375
370
380
375

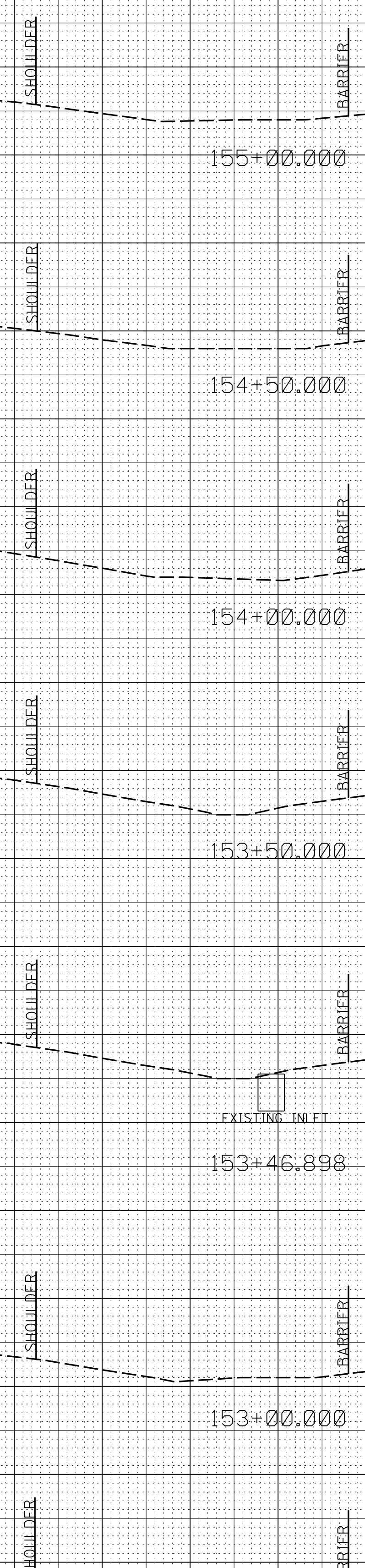

7/30/2019 8:35 AM LAY-HOLMES4.DGN

80 60 40 20 0 20 40 60 80 80 60 40 20 152+50.000 20 40

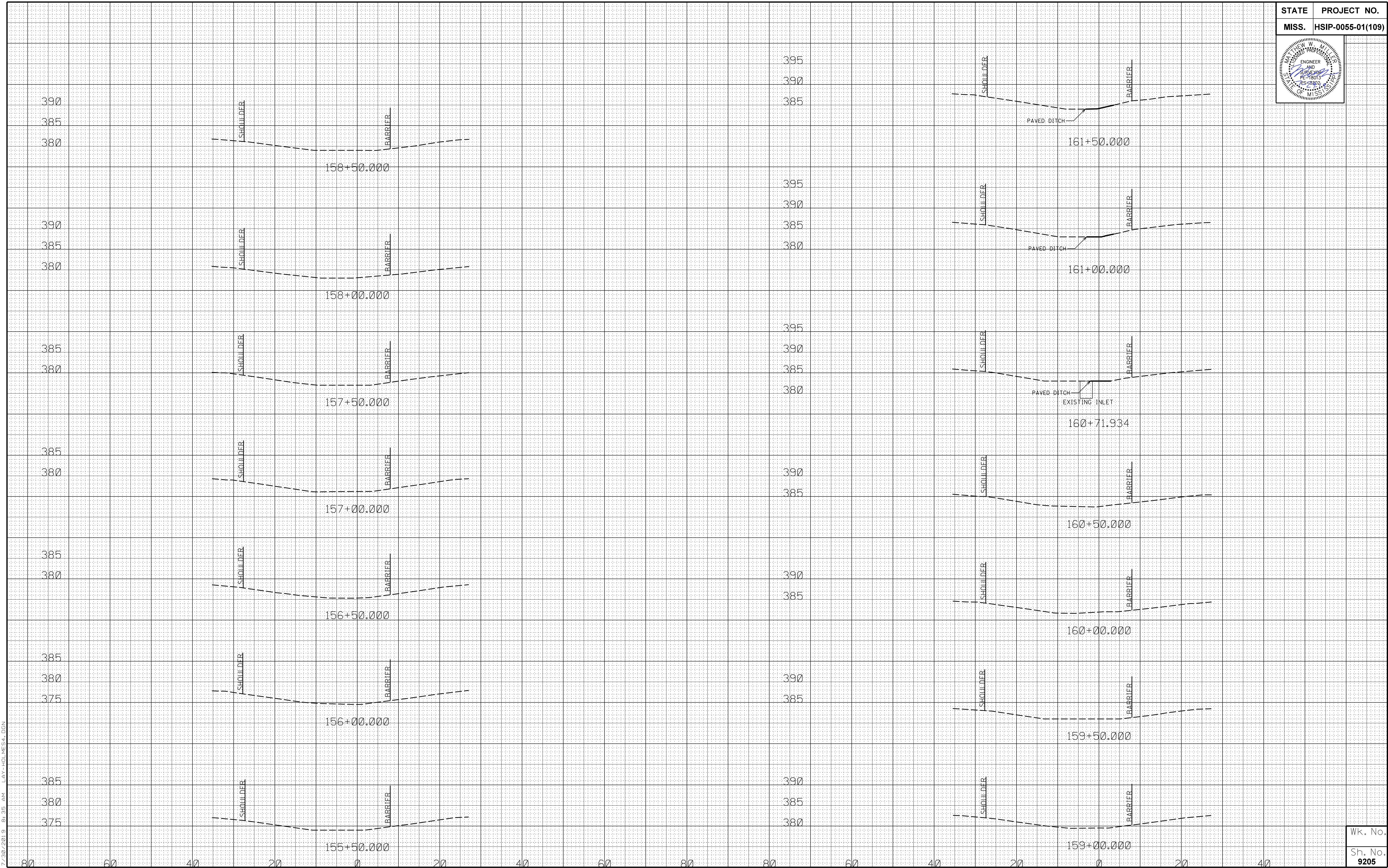
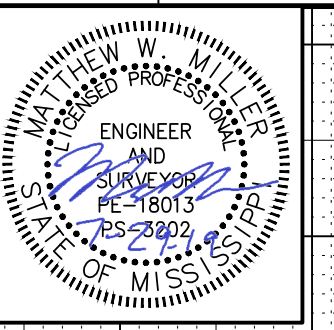

7/30/2019 8:35 AM LAY-HOLMES4.DGN

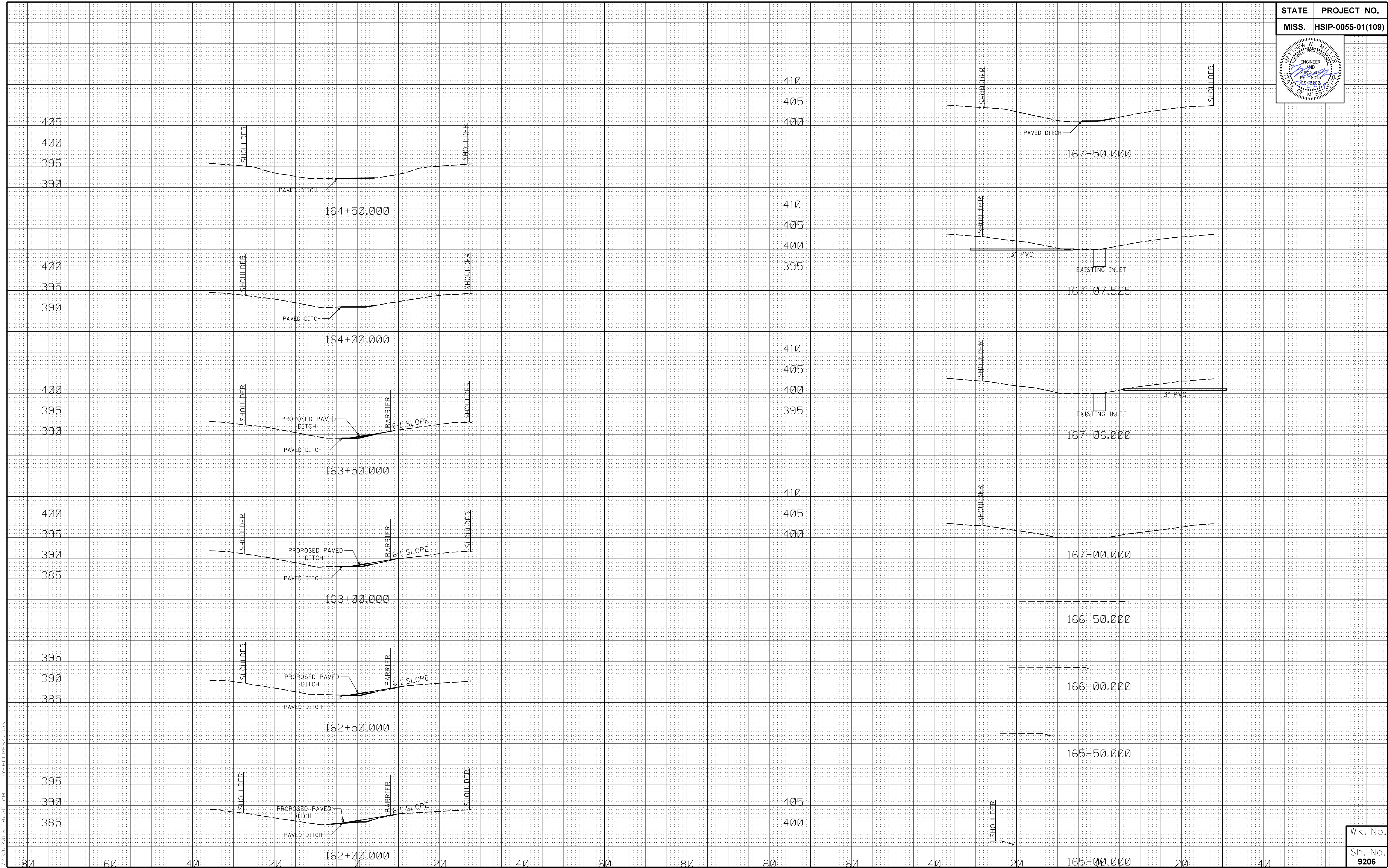
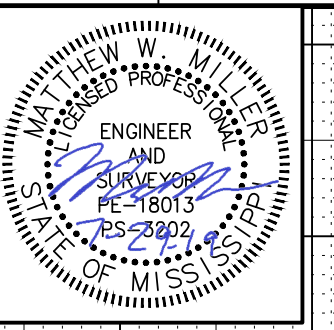

7/30/2019 8:35 AM LAY-HOLMES4.DGN

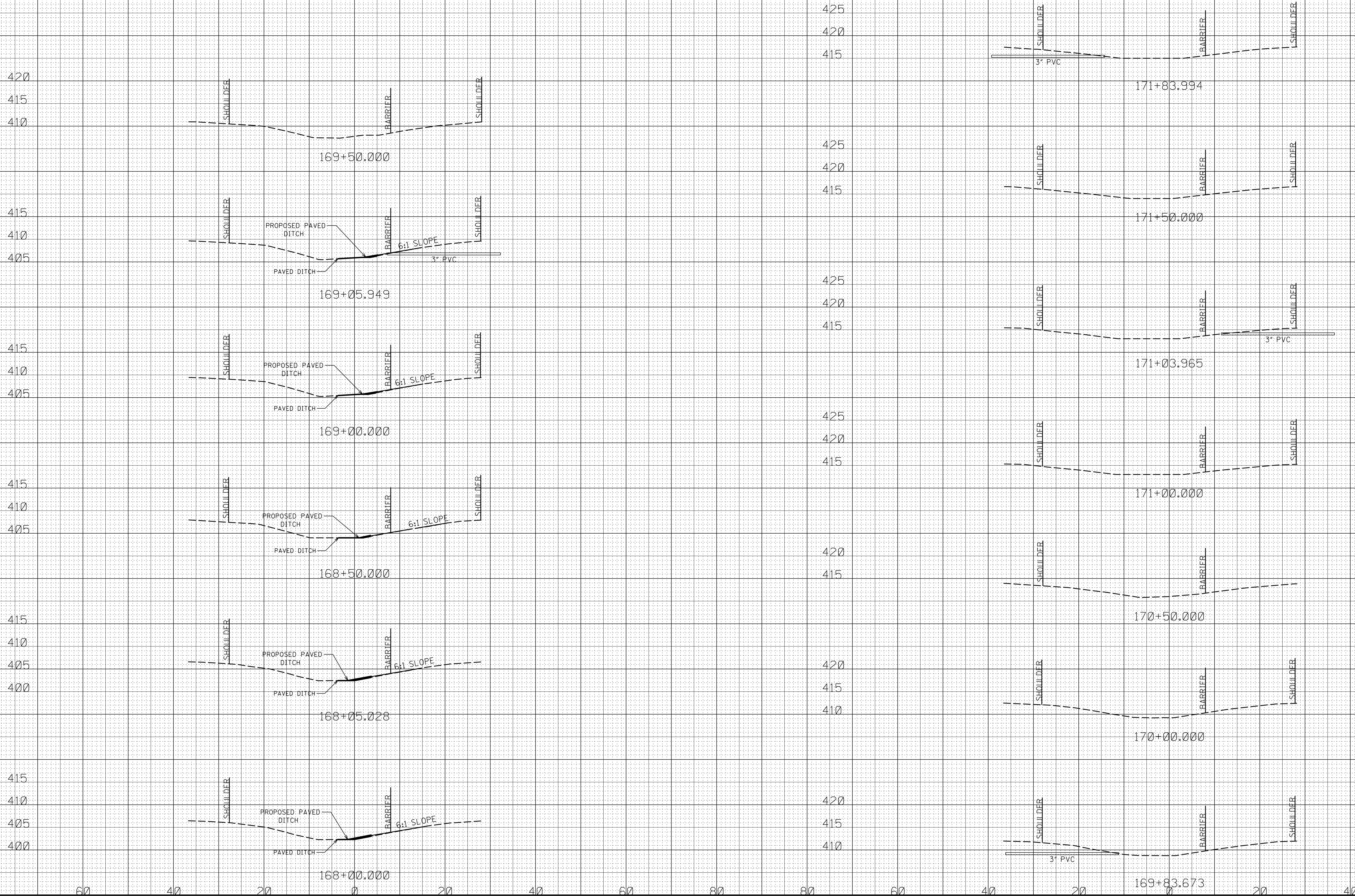
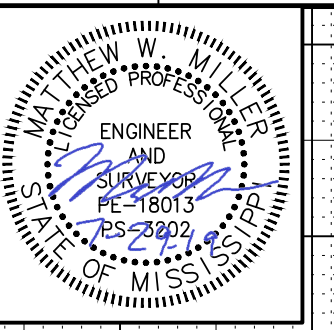

7/30/2019 8:35 AM LAY-HOLMES4.DGN

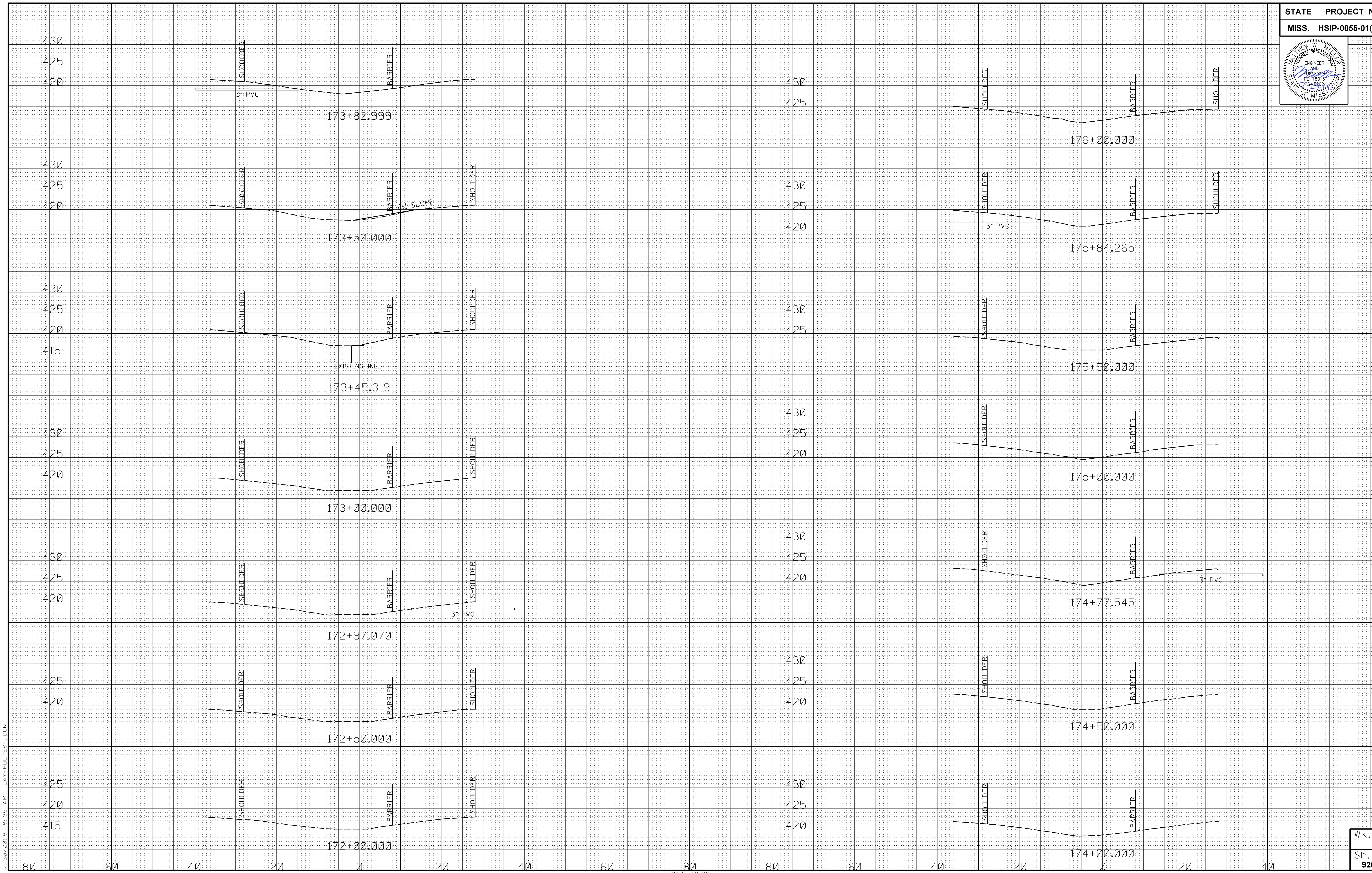
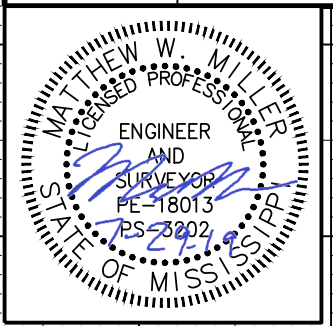

7/30/2019 8:35 AM LAY-HOLMES4.DGN

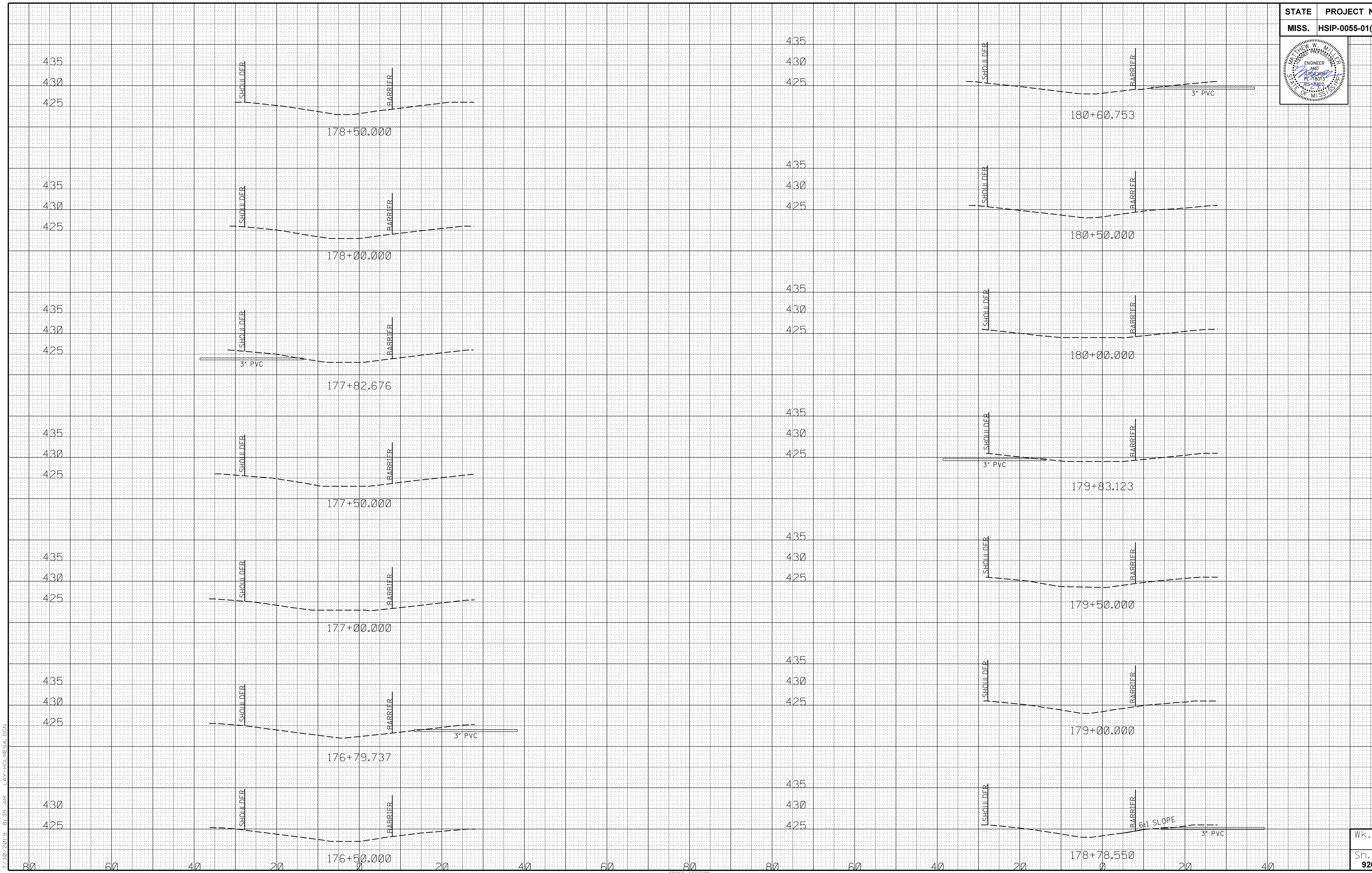
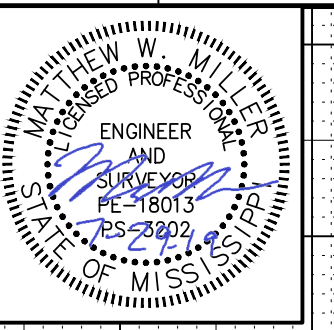

7/30/2019 8:35 AM LAY-HOLMES4.DGN

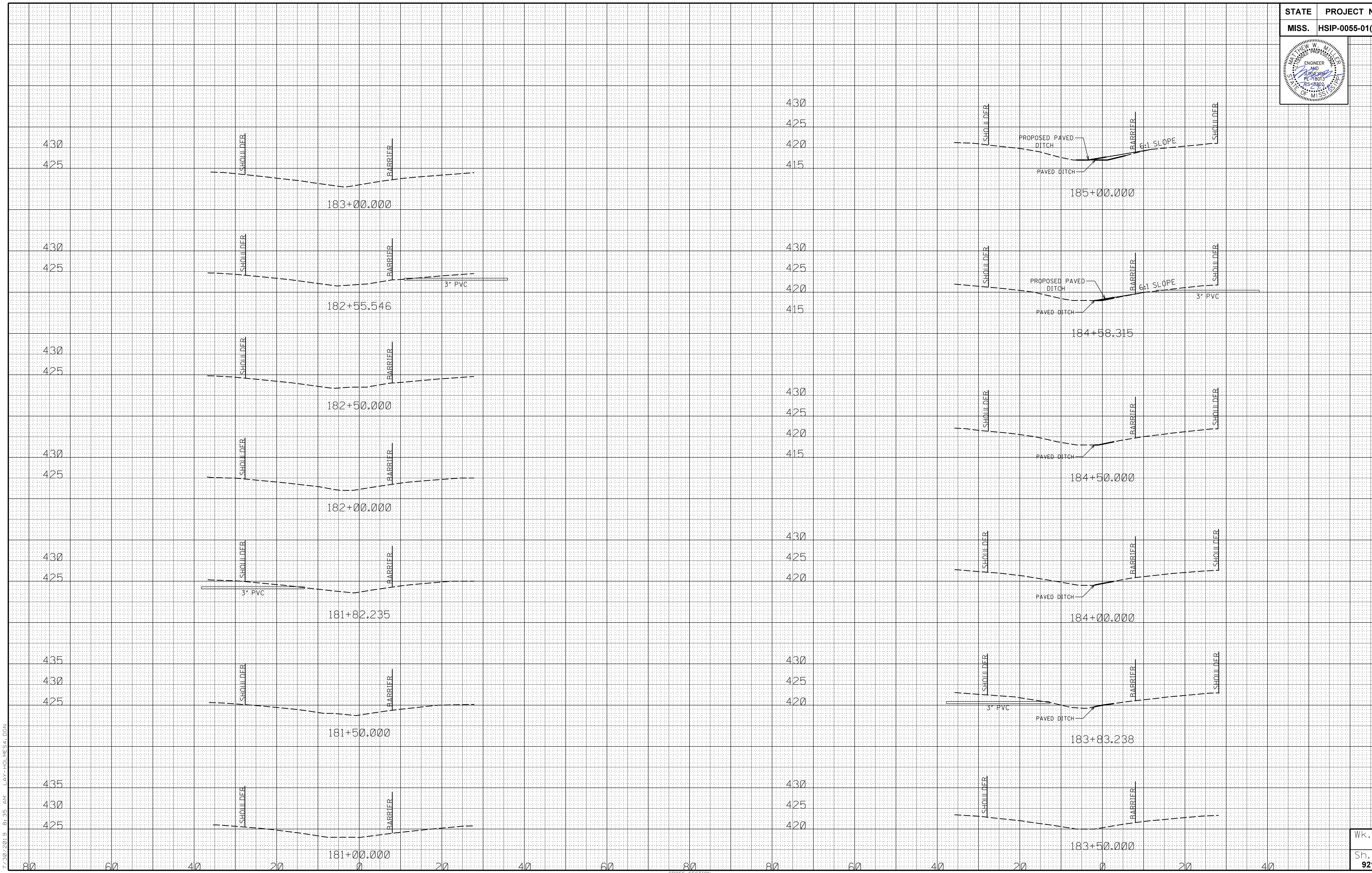
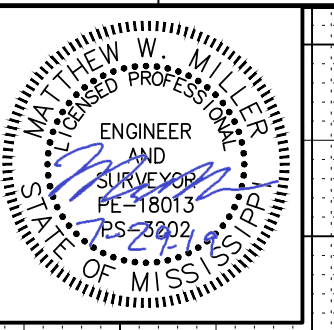

7/30/2019 8:35 AM LAY-HOLMES4.DGN

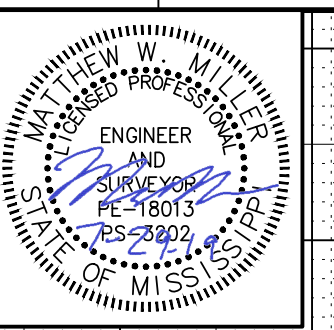

425
420
415
425
420
415
425
420
415
425
420
415
425
420
415
430
425
420
415

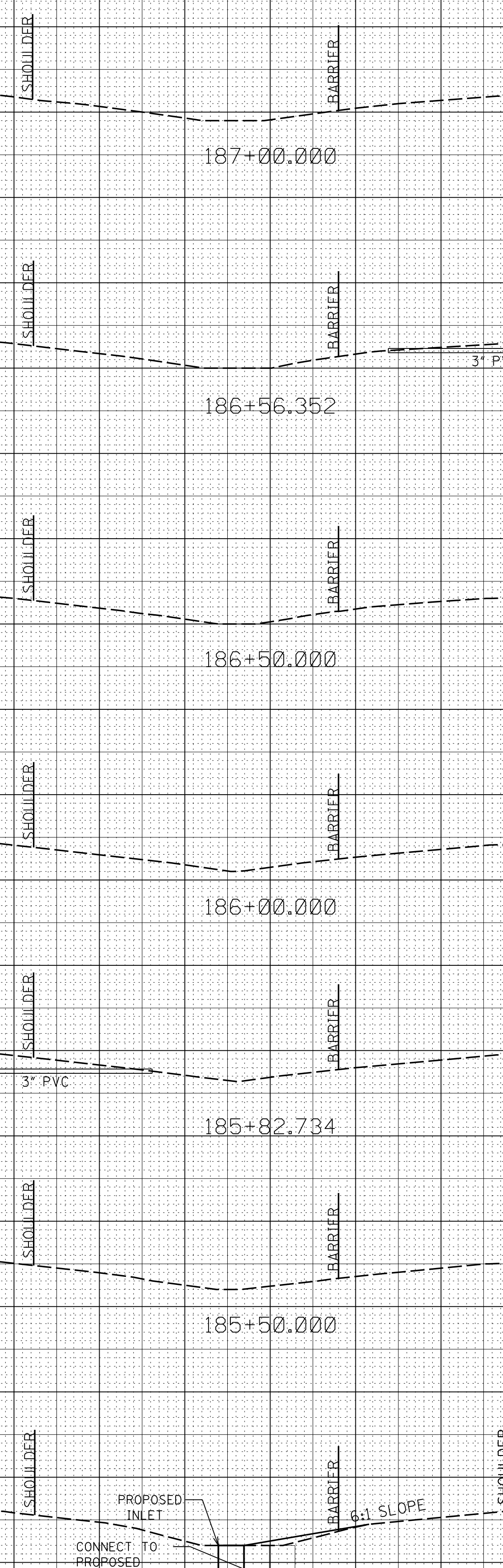

415
410
420
415
410
405
420
415
410
420
415
410
420
415
410
425
420
415

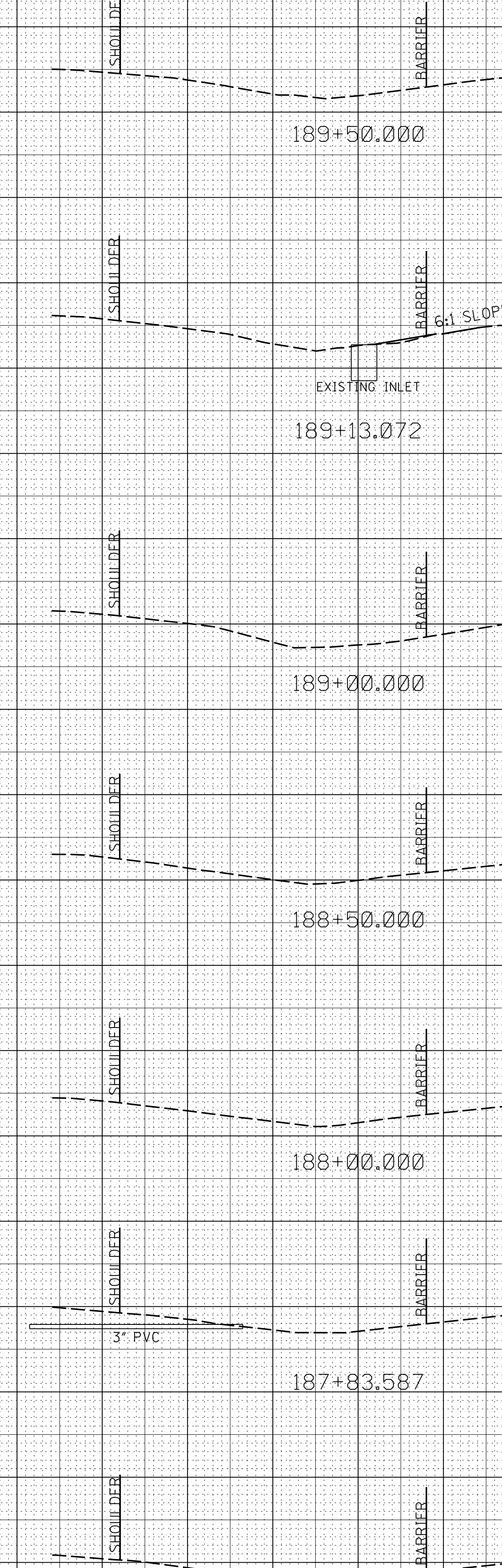

7/30/2019 8:35 AM LAY-HOLMES4.DGN

80 60 40 20 185+04.206 20 40 60 80 80 60 40 20 0 20 40

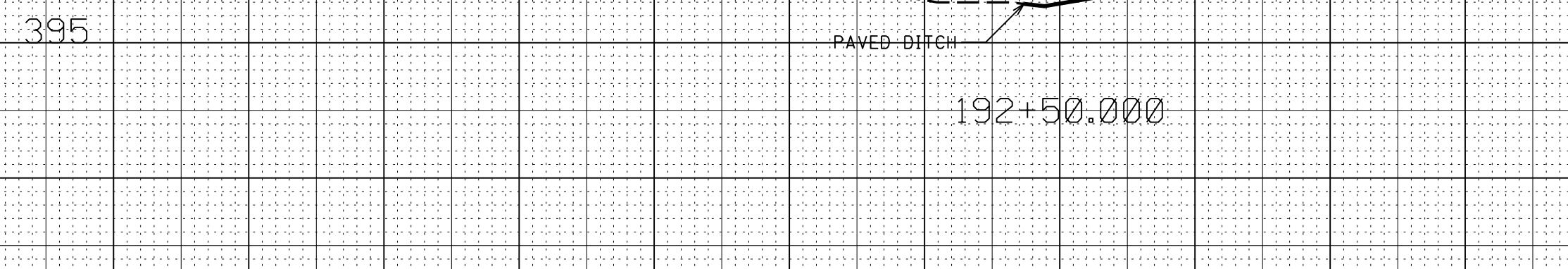
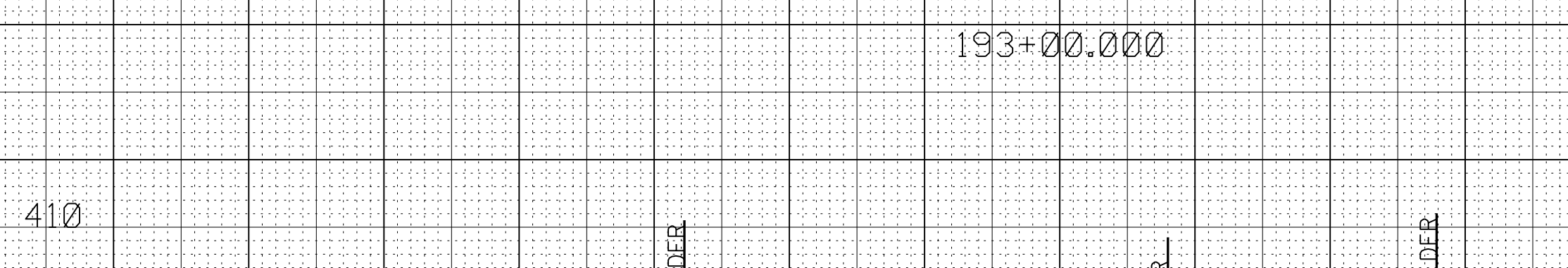
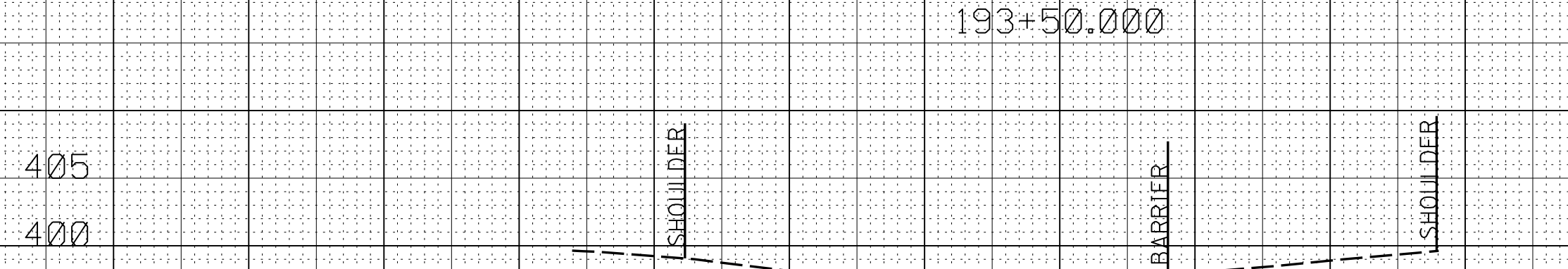
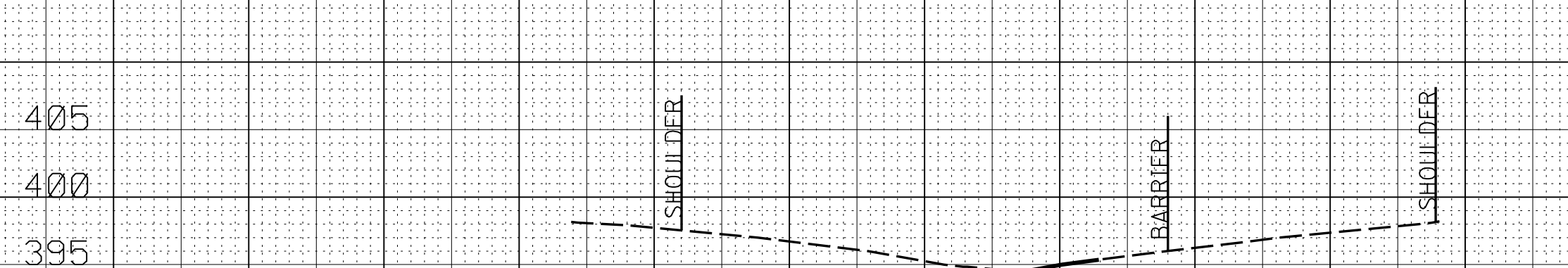
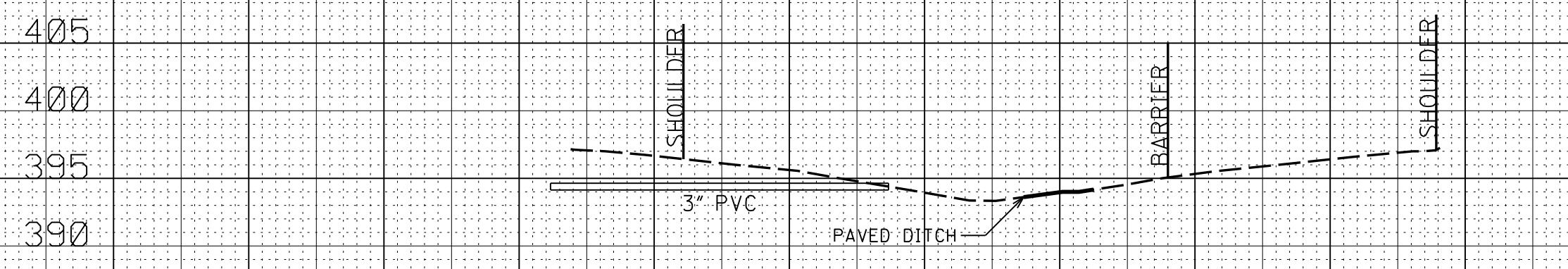
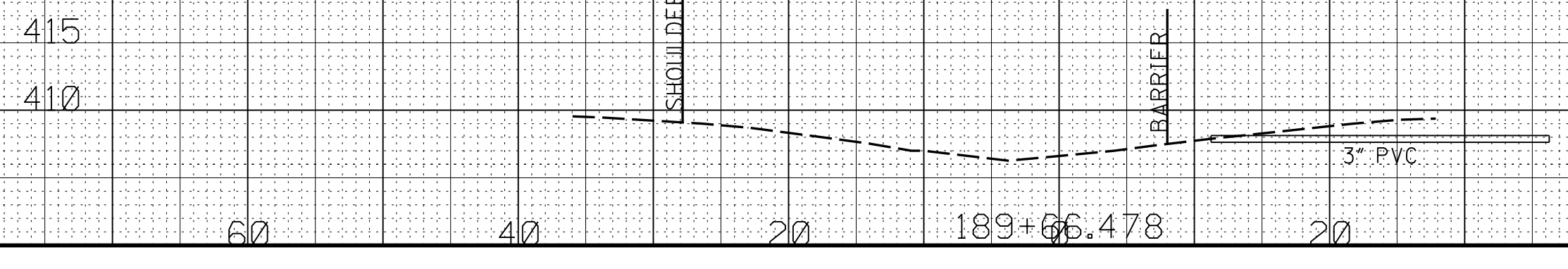
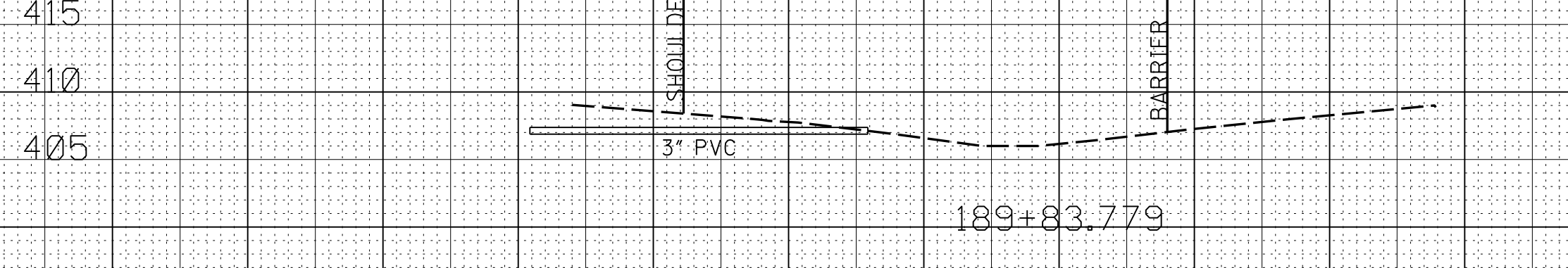
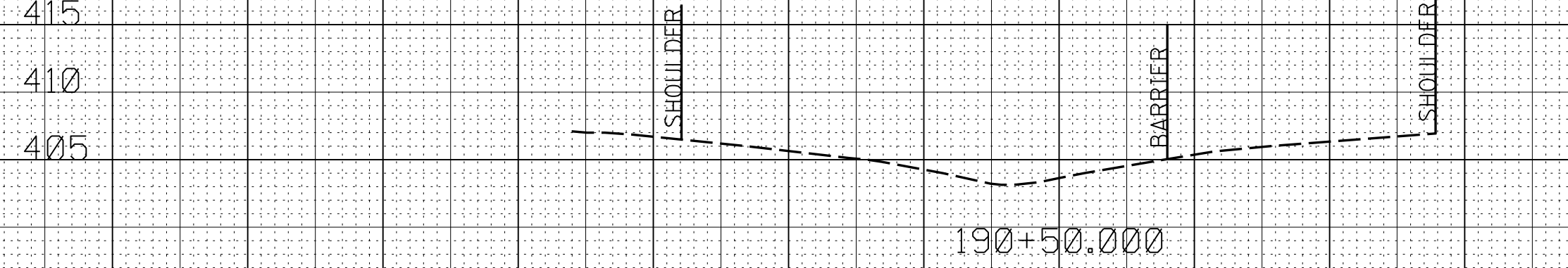
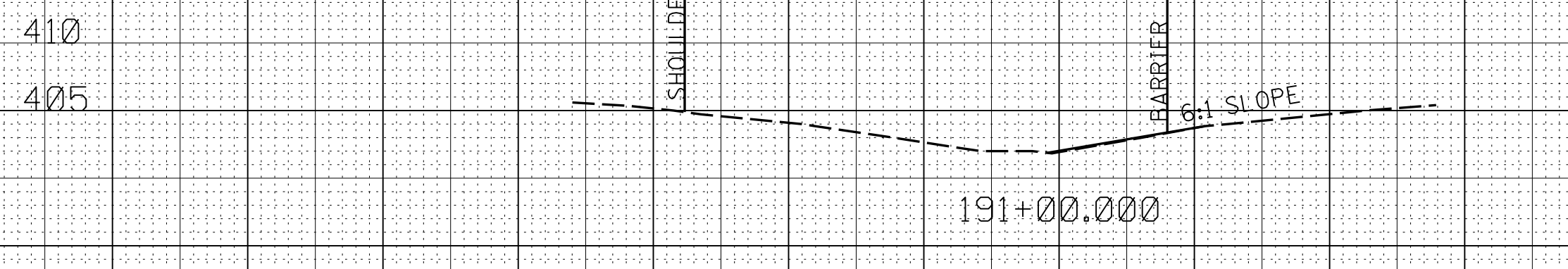
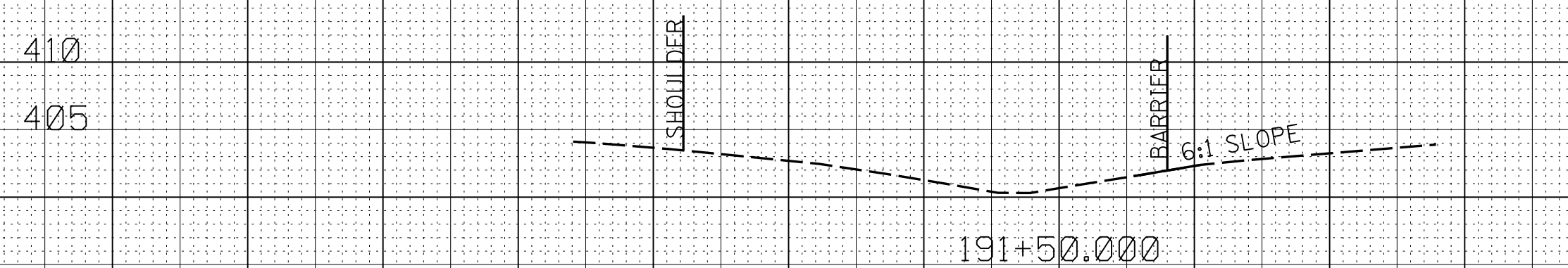
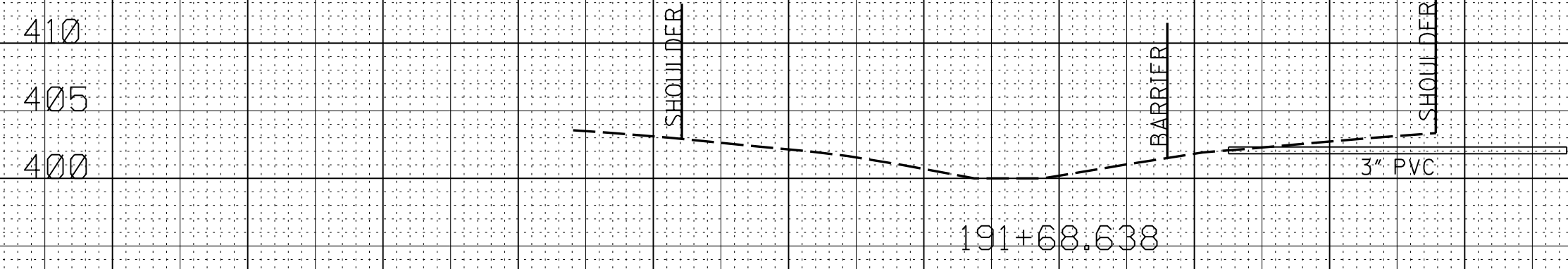
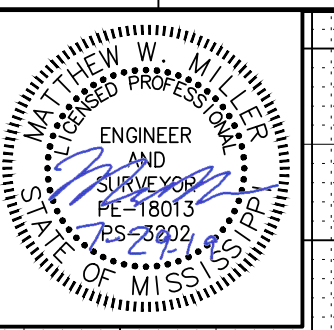

7/30/2019 8:35 AM LAY-HOLMES4.DGN

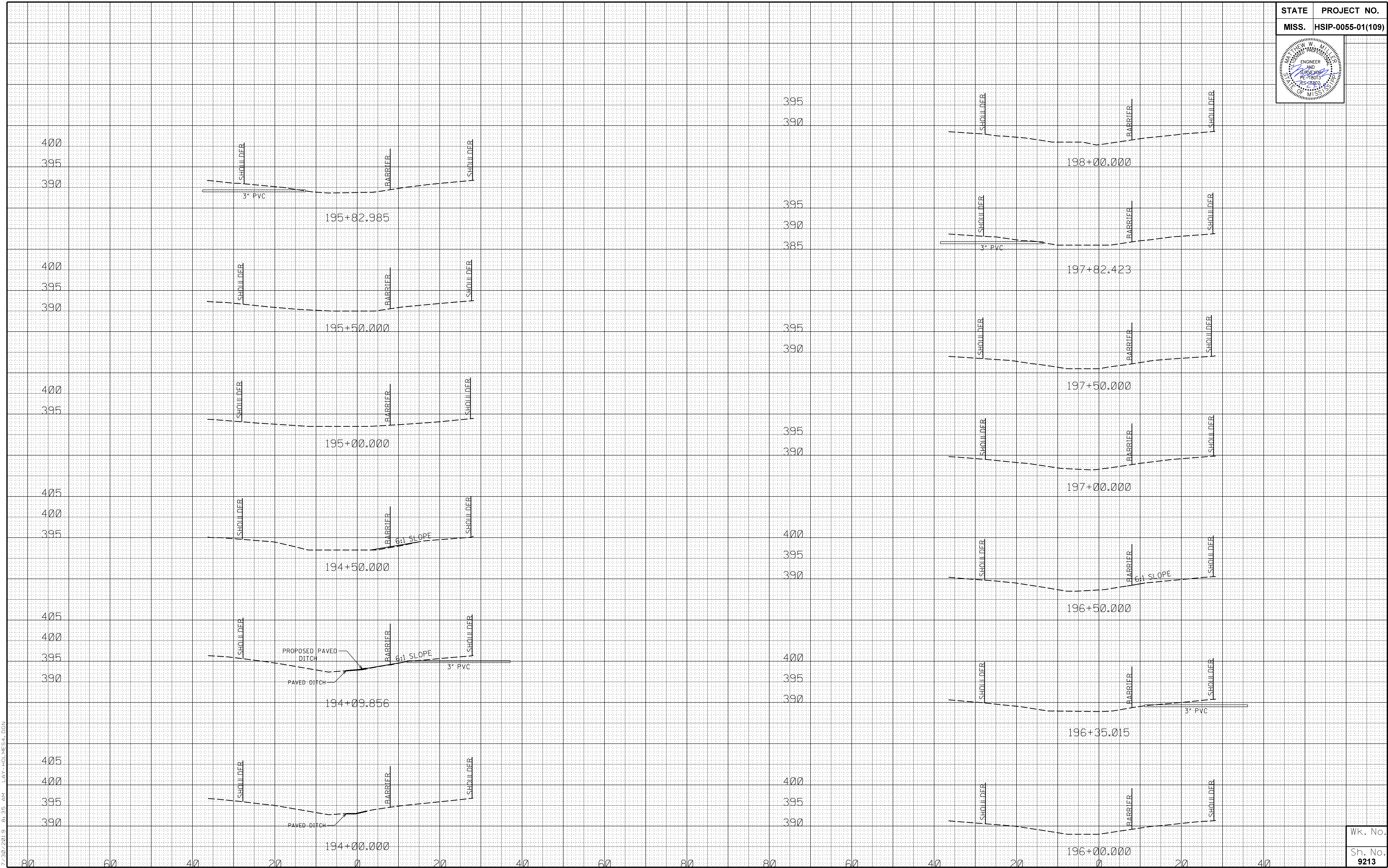
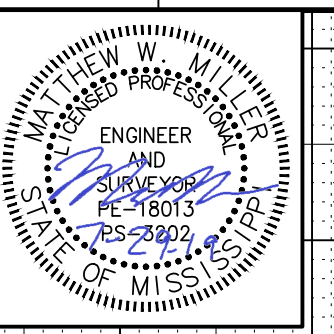

7/30/2019 8:35 AM LAY-HOLMES4.DGN

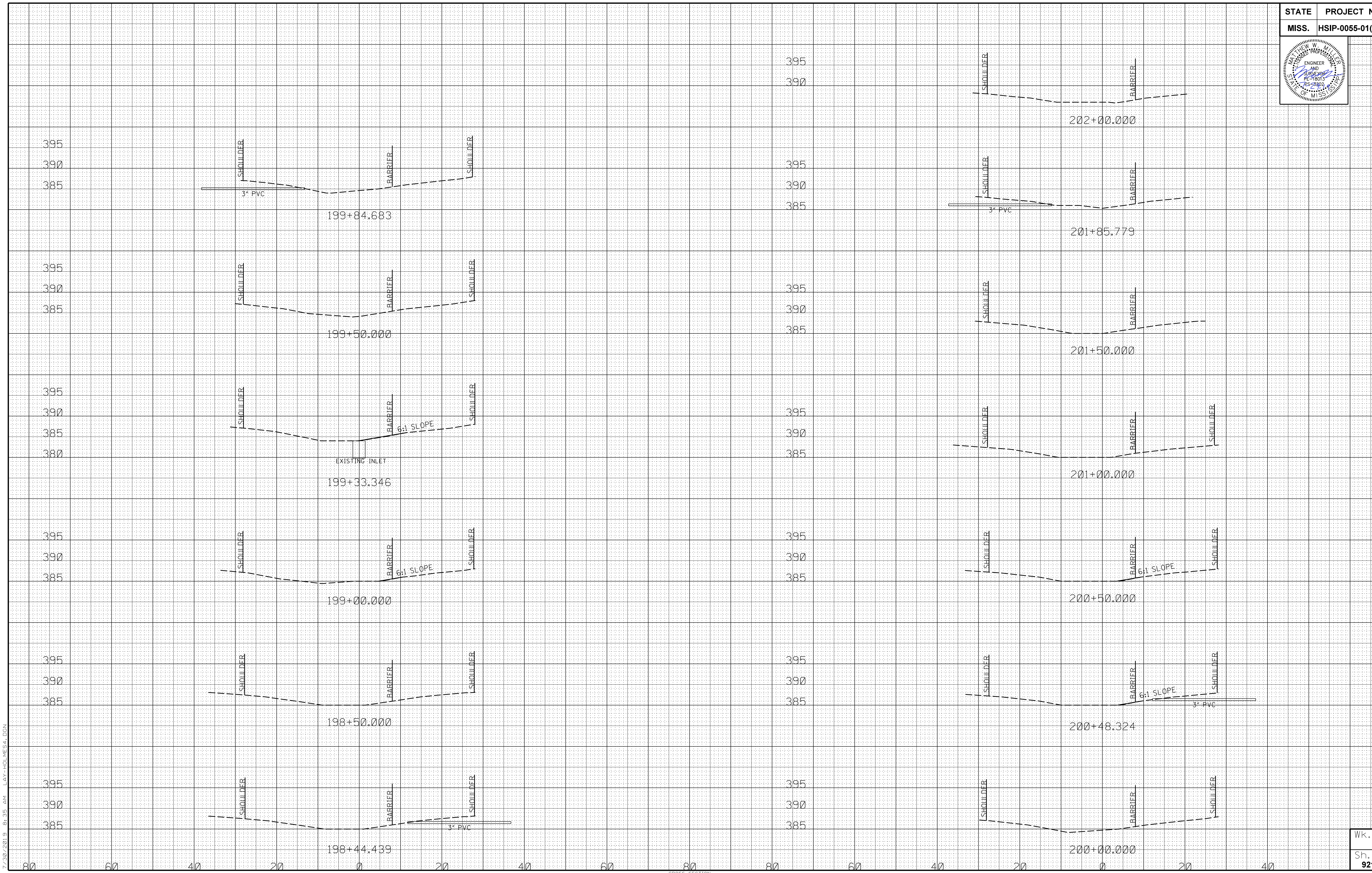
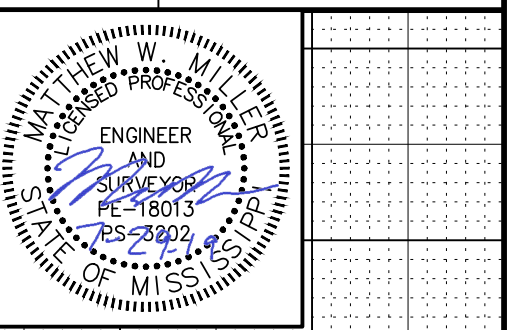

7/30/2019 8:35 AM LAY-HOLMES4.DGN

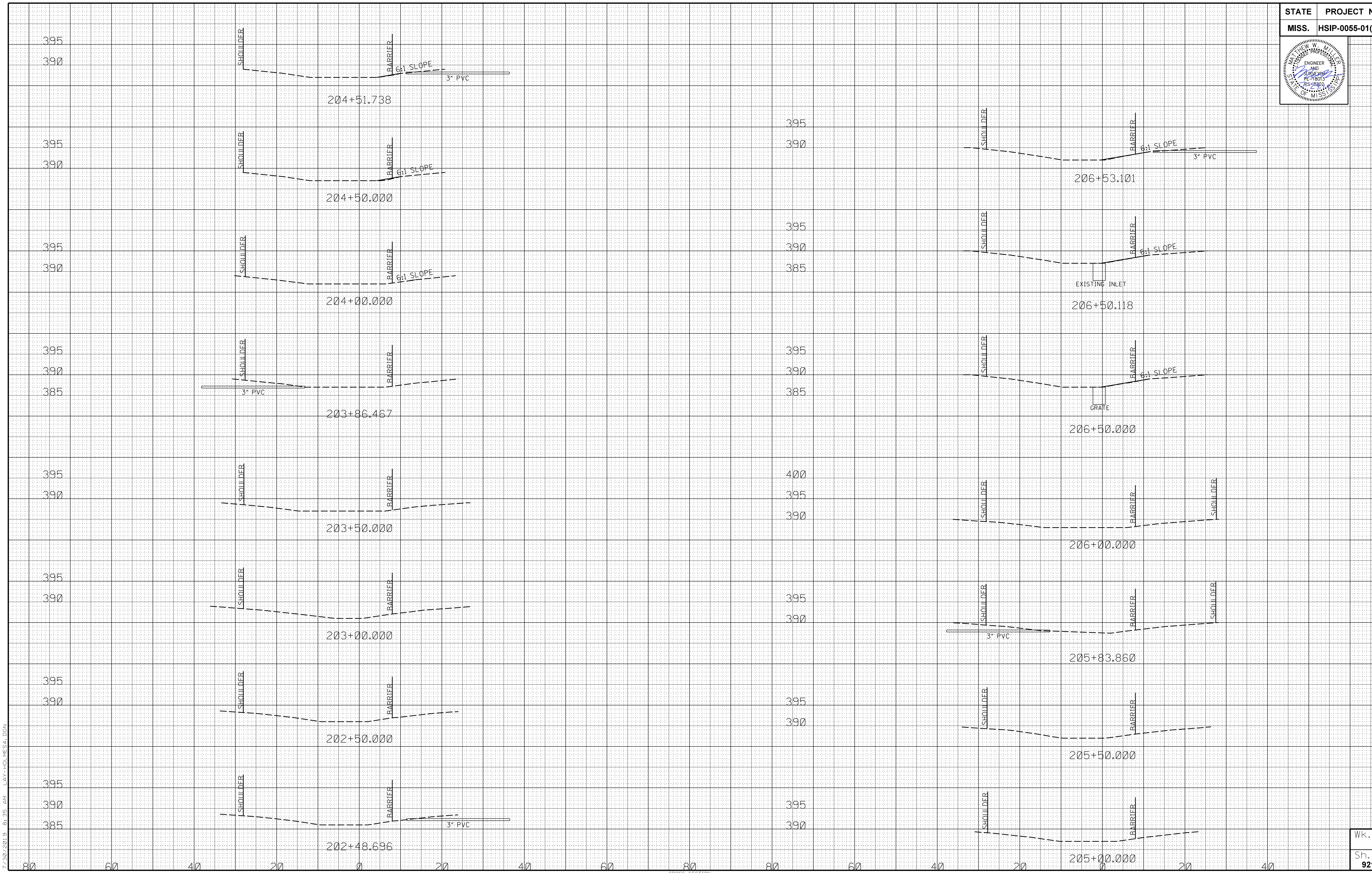
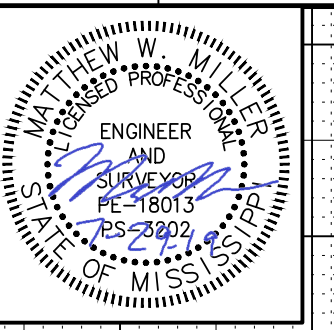

7/30/2019 8:35 AM LAY-HOLMES4.DGN

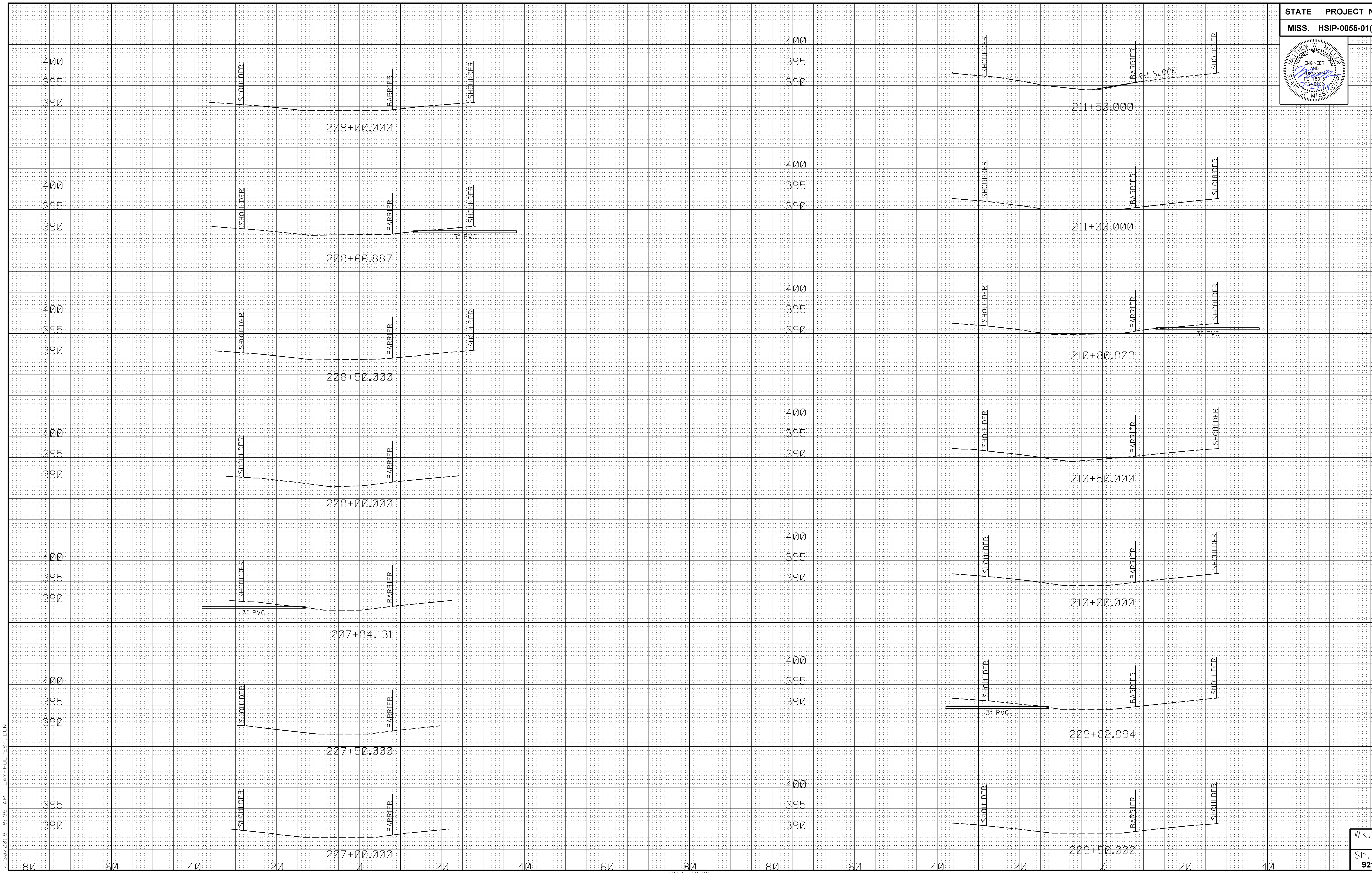
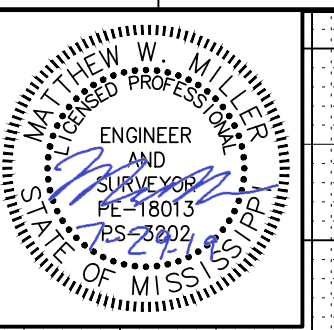

7/30/2019 8:35 AM LAY-HOLMES4.DGN

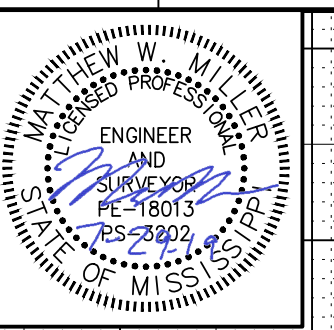

213+50.000



213+11.145

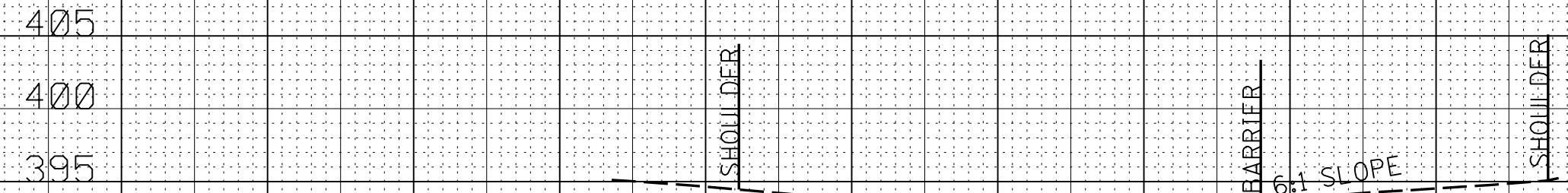

213+00.000

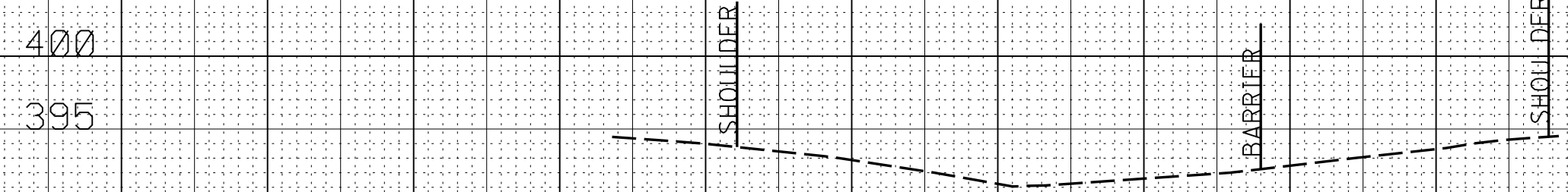

212+50.000

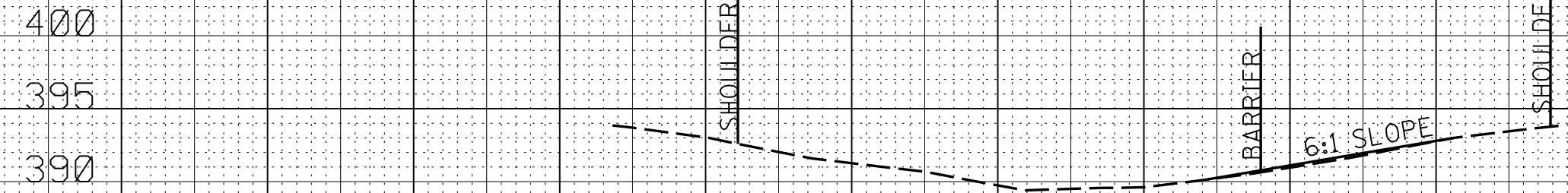

212+00.000



211+83.326

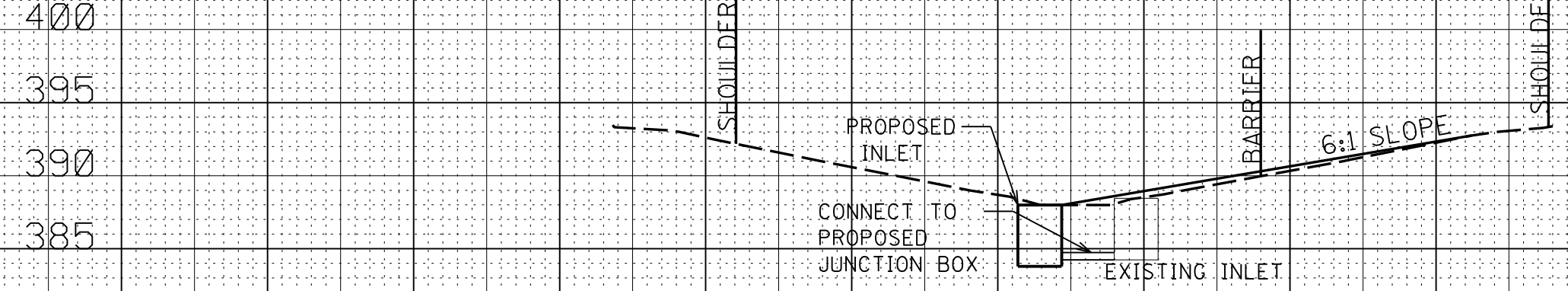

211+71.046

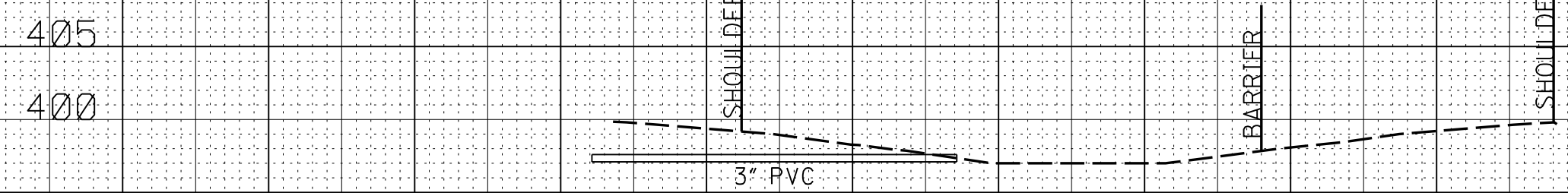

215+81.858

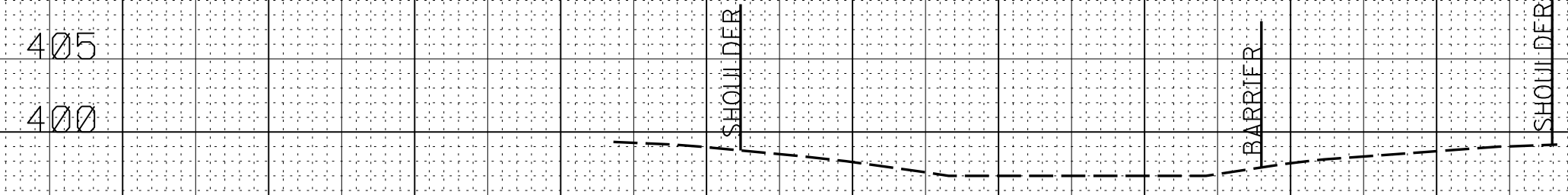

215+50.000



215+47.735

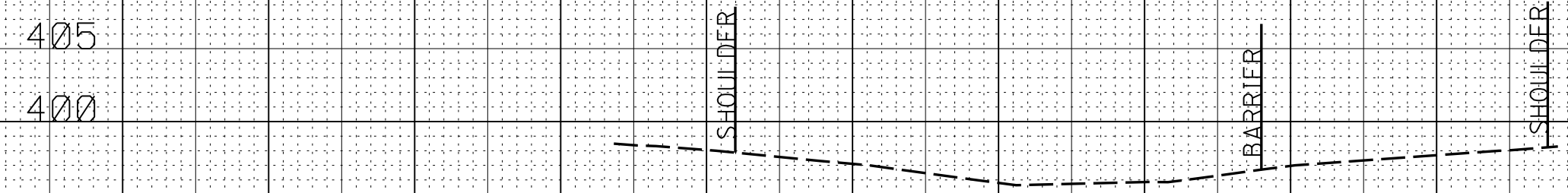

215+00.000

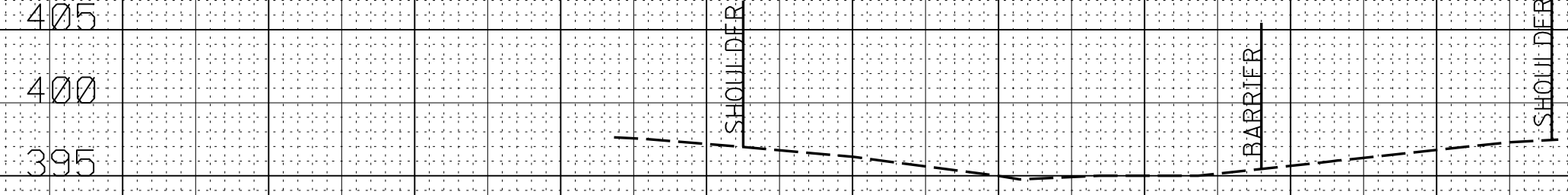

214+50.000



214+00.000

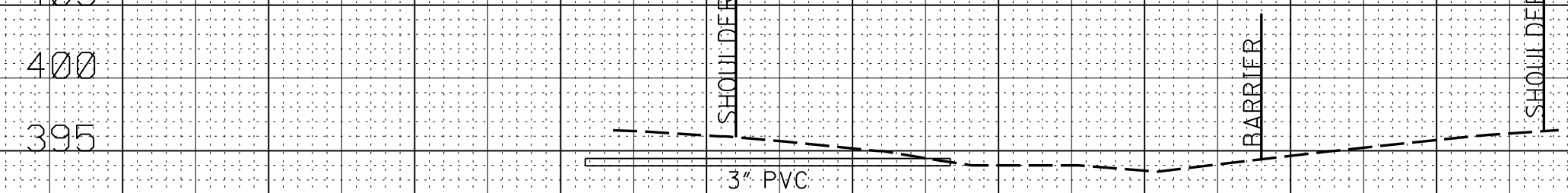

213+80.819

7/30/2019 8:35 AM LAY-HOLMES4.DGN

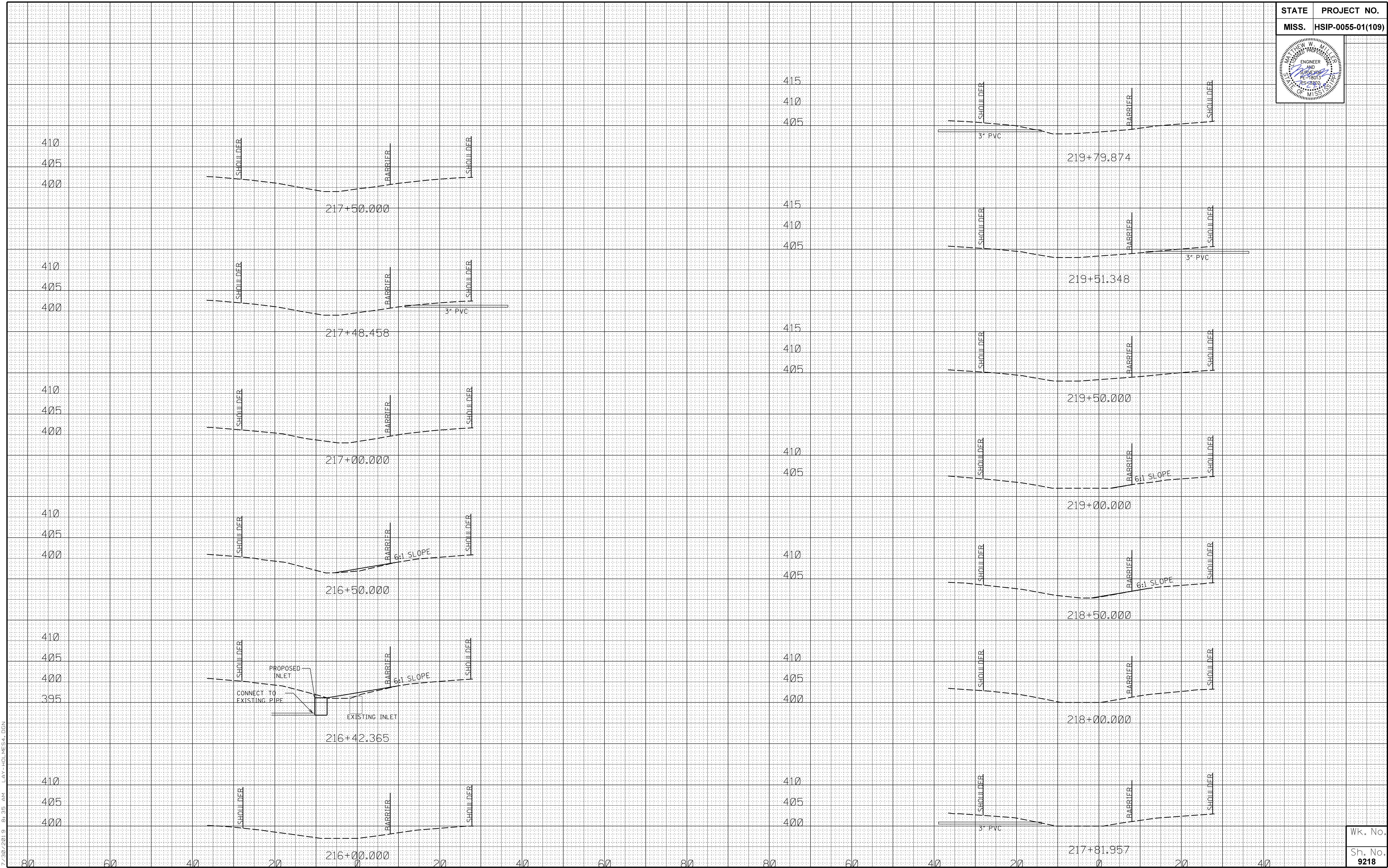
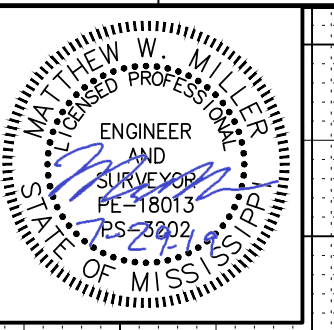

7/30/2019 8:35 AM LAY-HOLMES4.DGN

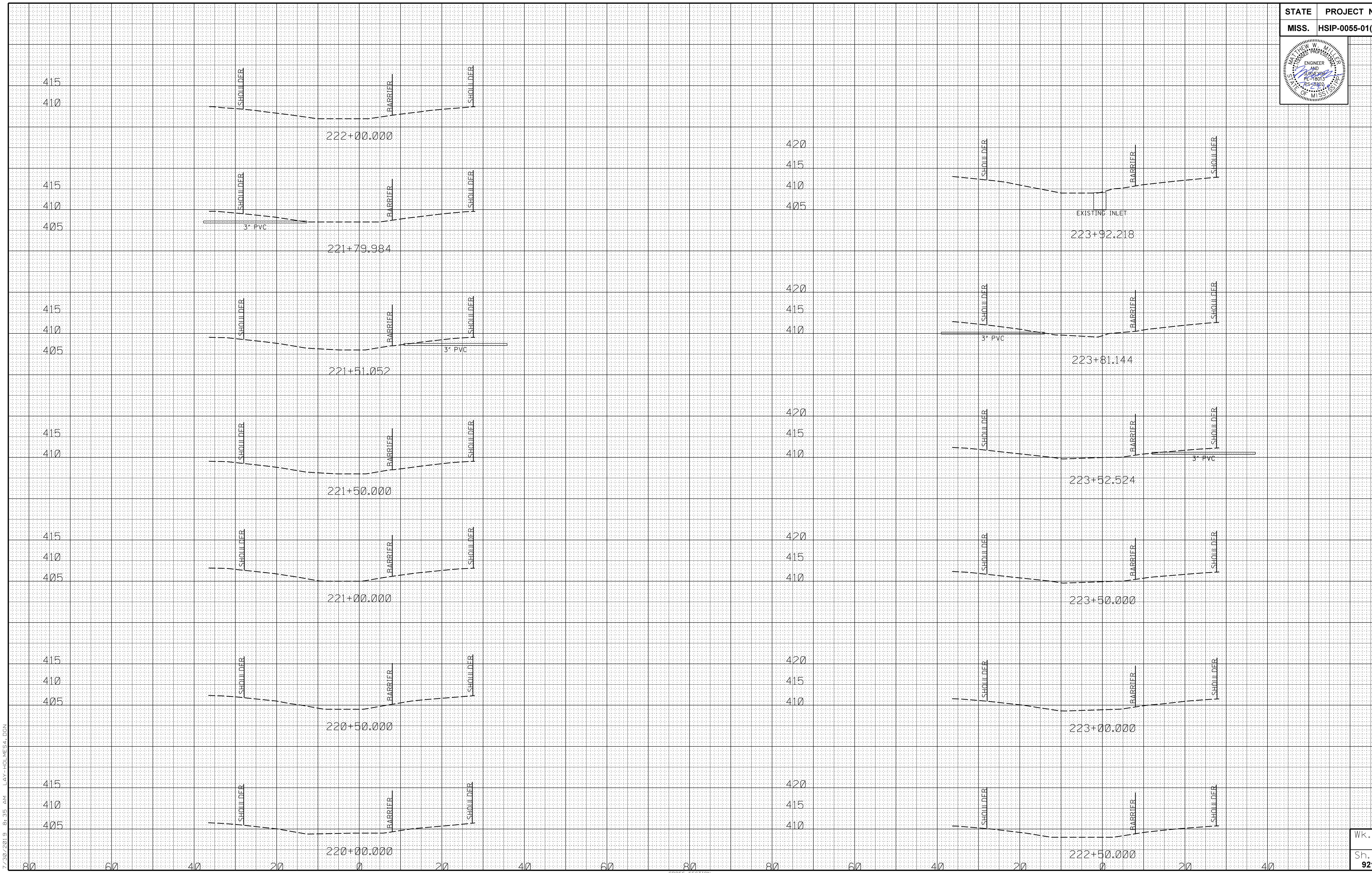
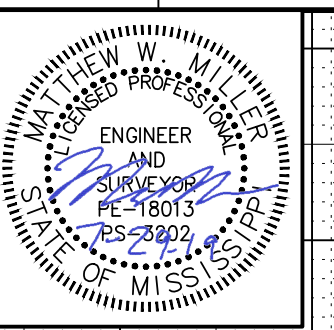

7/30/2019 8:35 AM LAY-HOLMES4.DGN

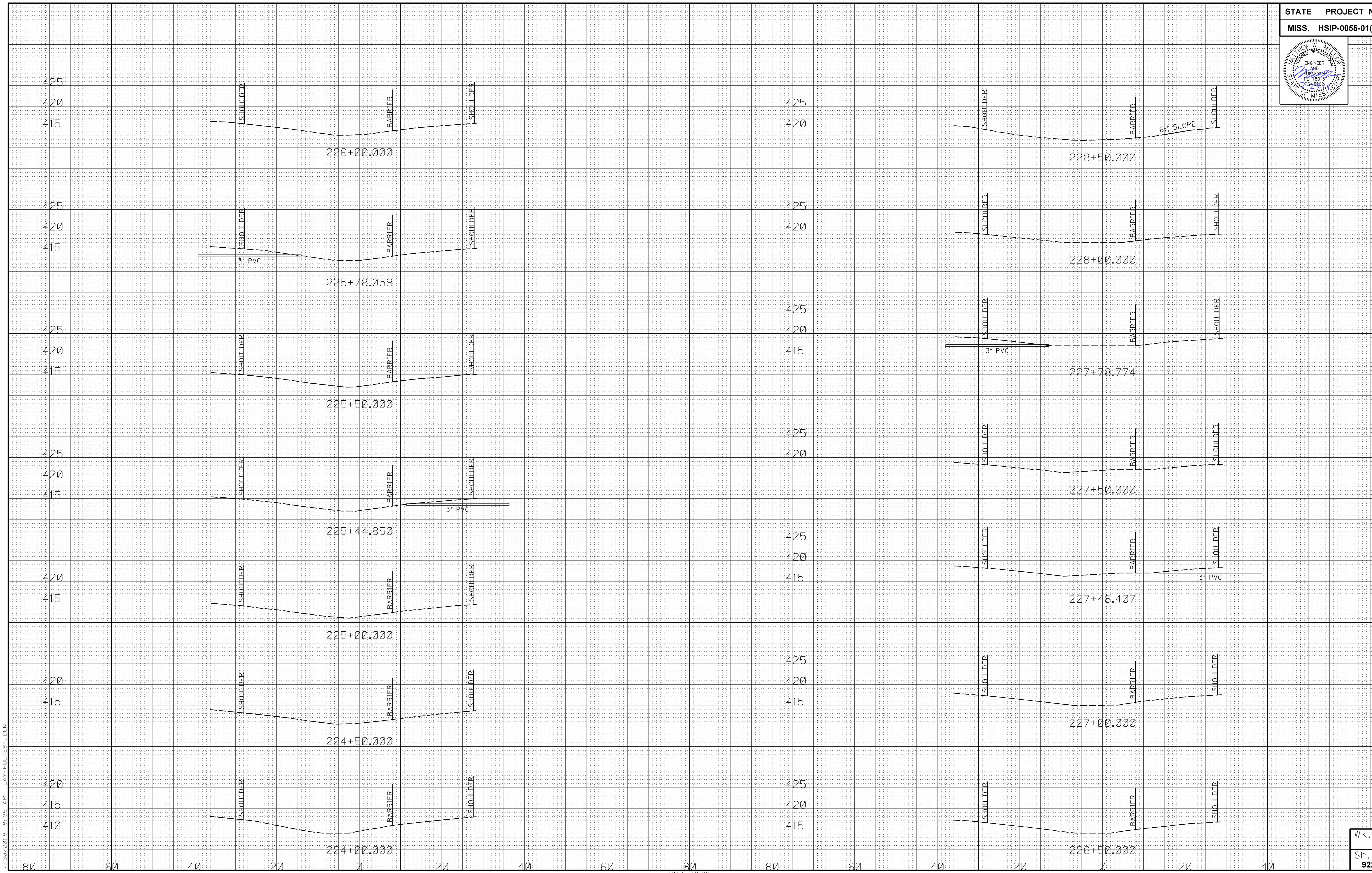
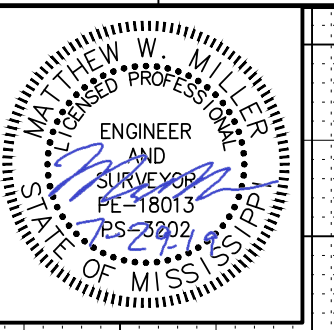

7/30/2019 8:35 AM LAY-HOLMES4.DGN

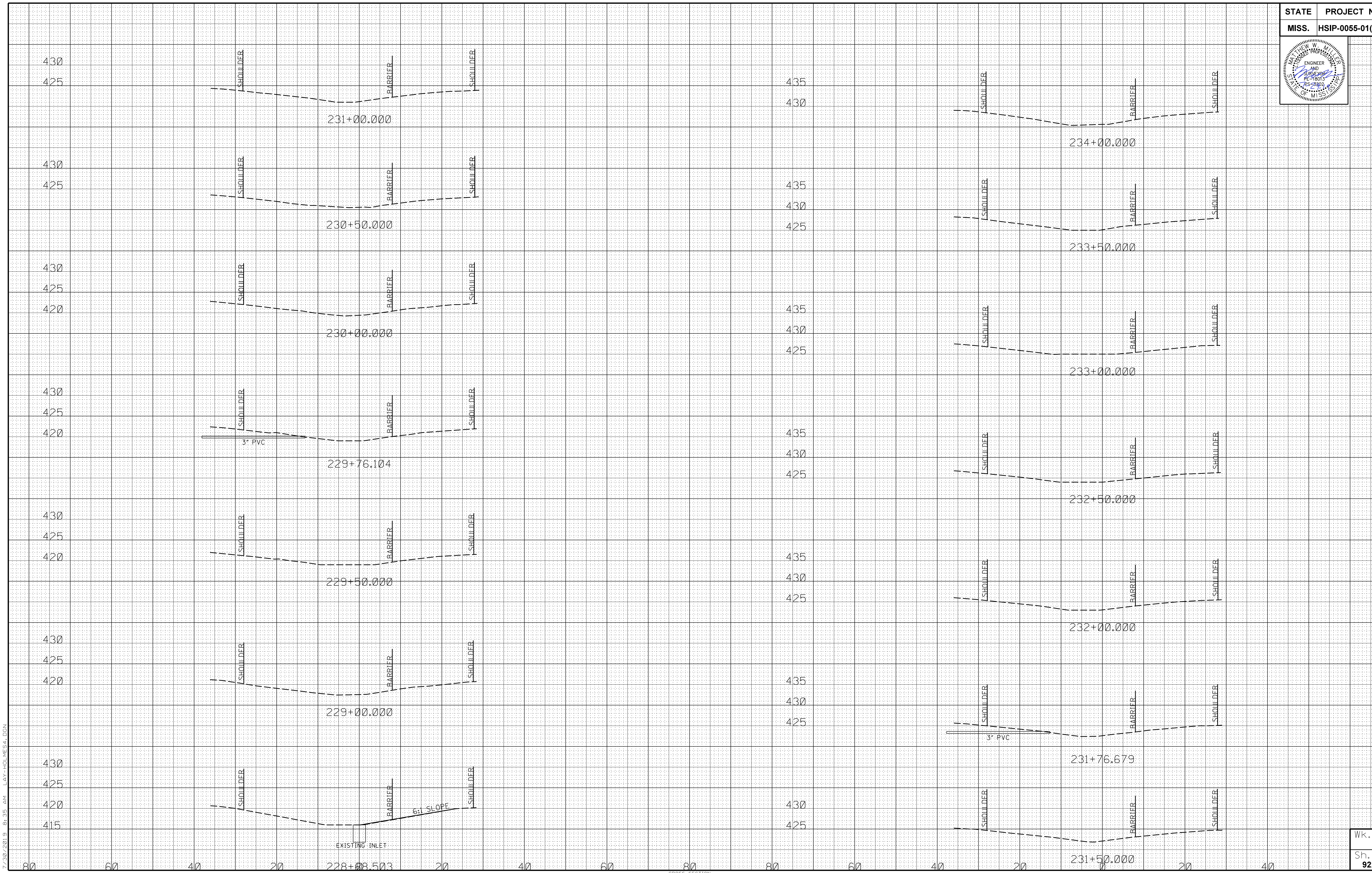
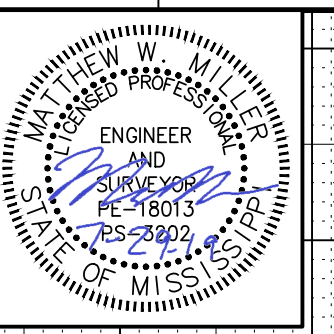

7/30/2019 8:35 AM LAY-HOLMES4.DGN

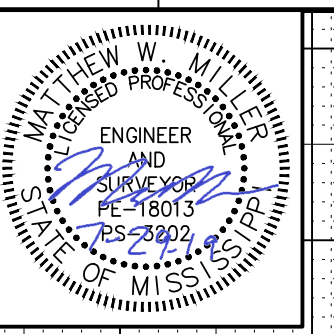

7/30/2019 8:36 AM LAY-HOLMES4.DGN

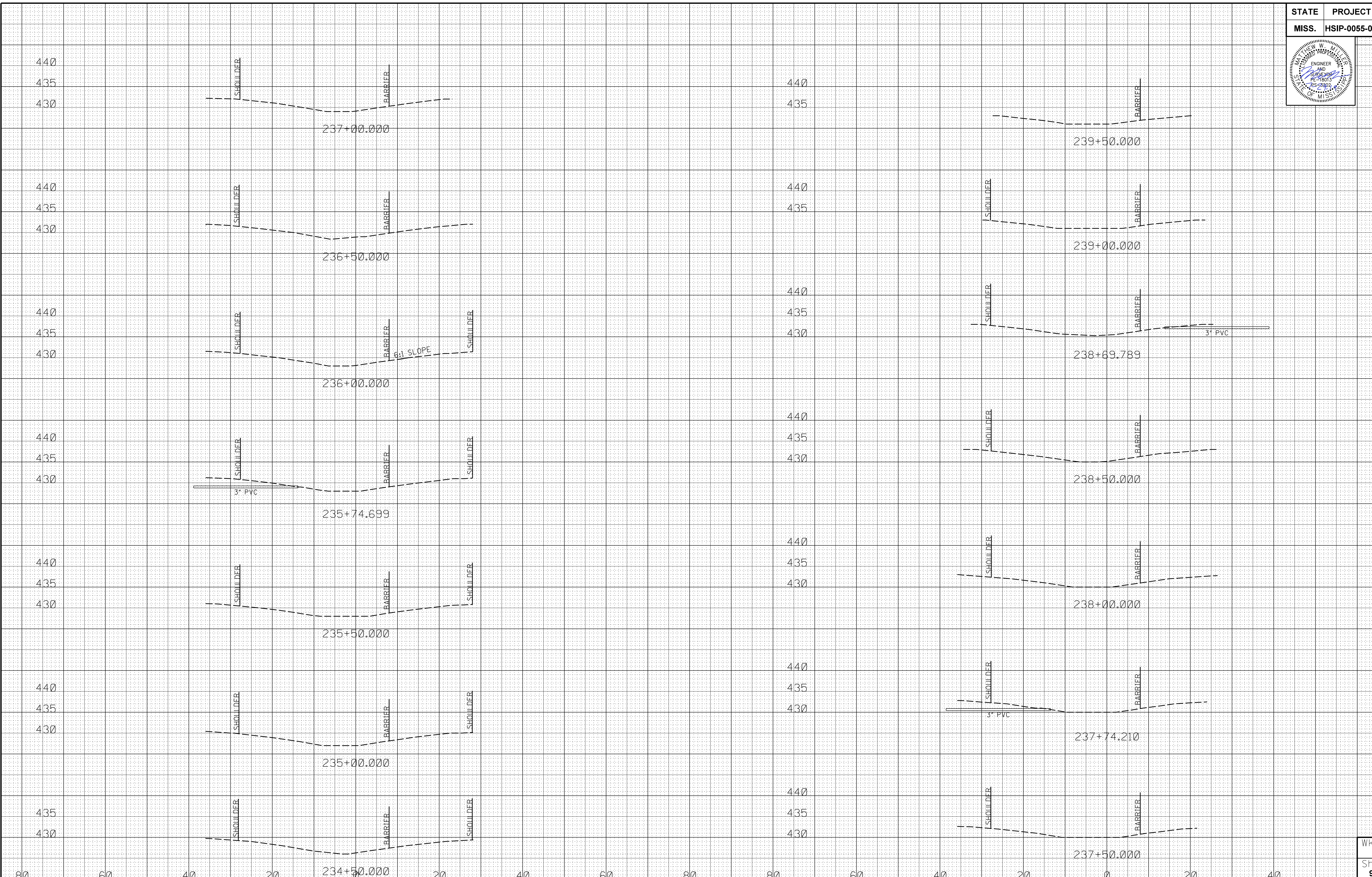

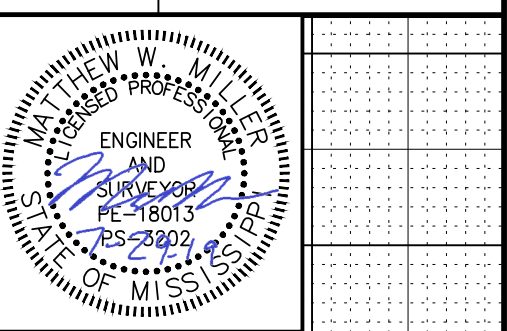

440
435
440
435
440
435
440
435
440
435
440
435
440
435
440
435
440
435
440
435
440
435

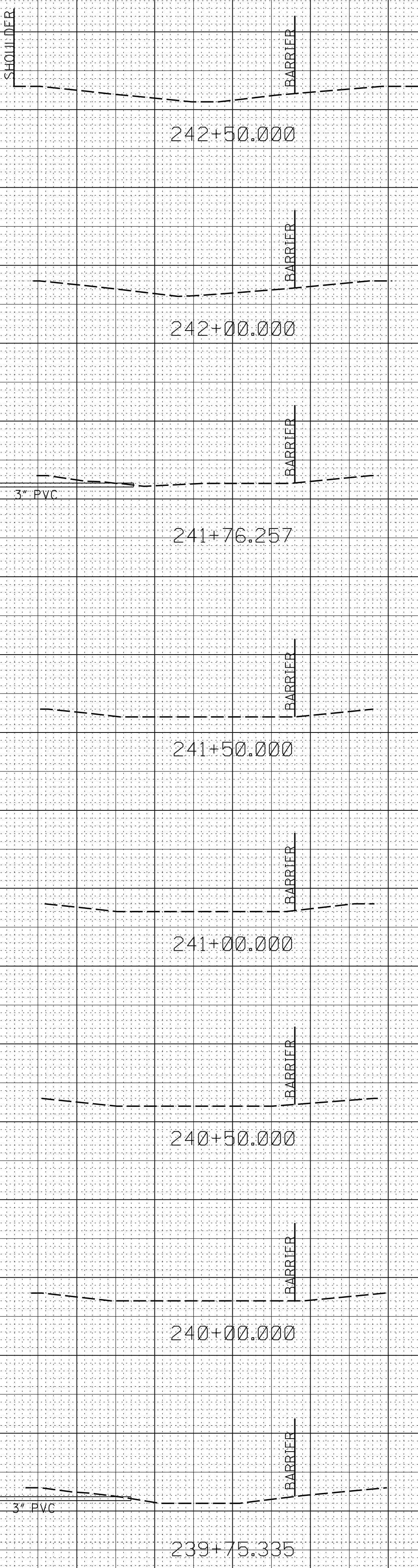

440
435
430
440
435
430
440
435
430
440
435
430
440
435
430
440
435
430
440
435
430
440
435
430

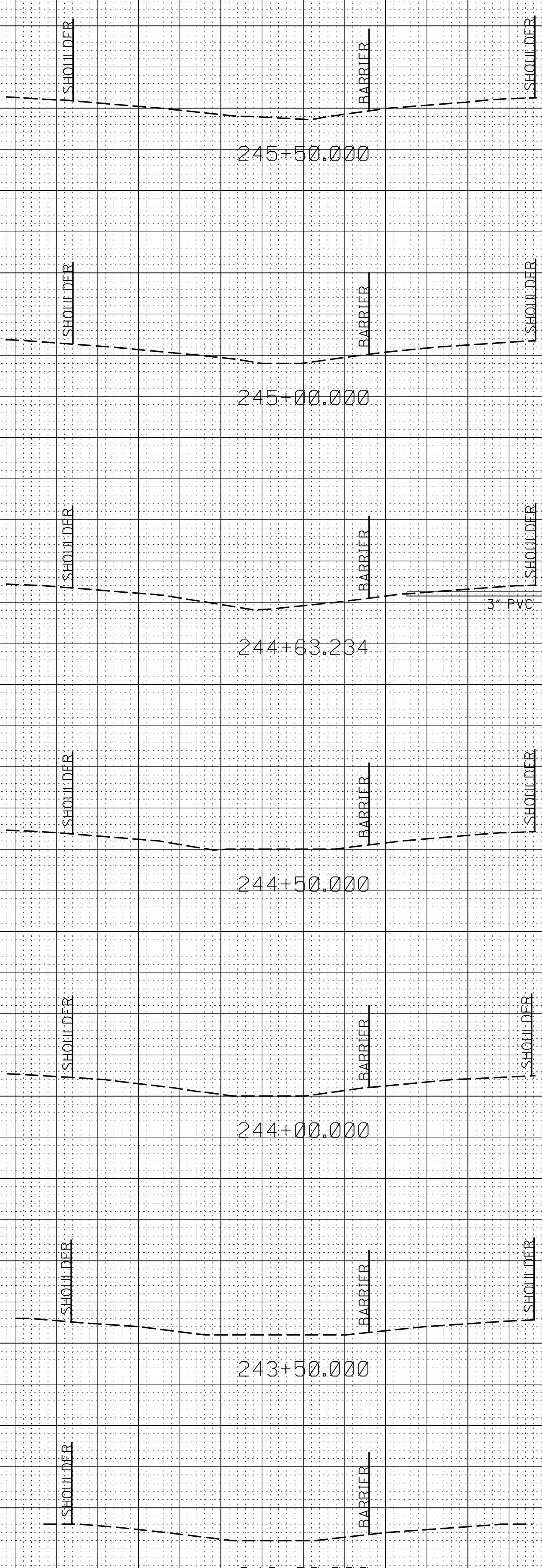

7/30/2019 8:36 AM LAY-HOLMES4.DGN

80 60 40 20 0 20 40 60 80 80 60 40 20 40 20 40

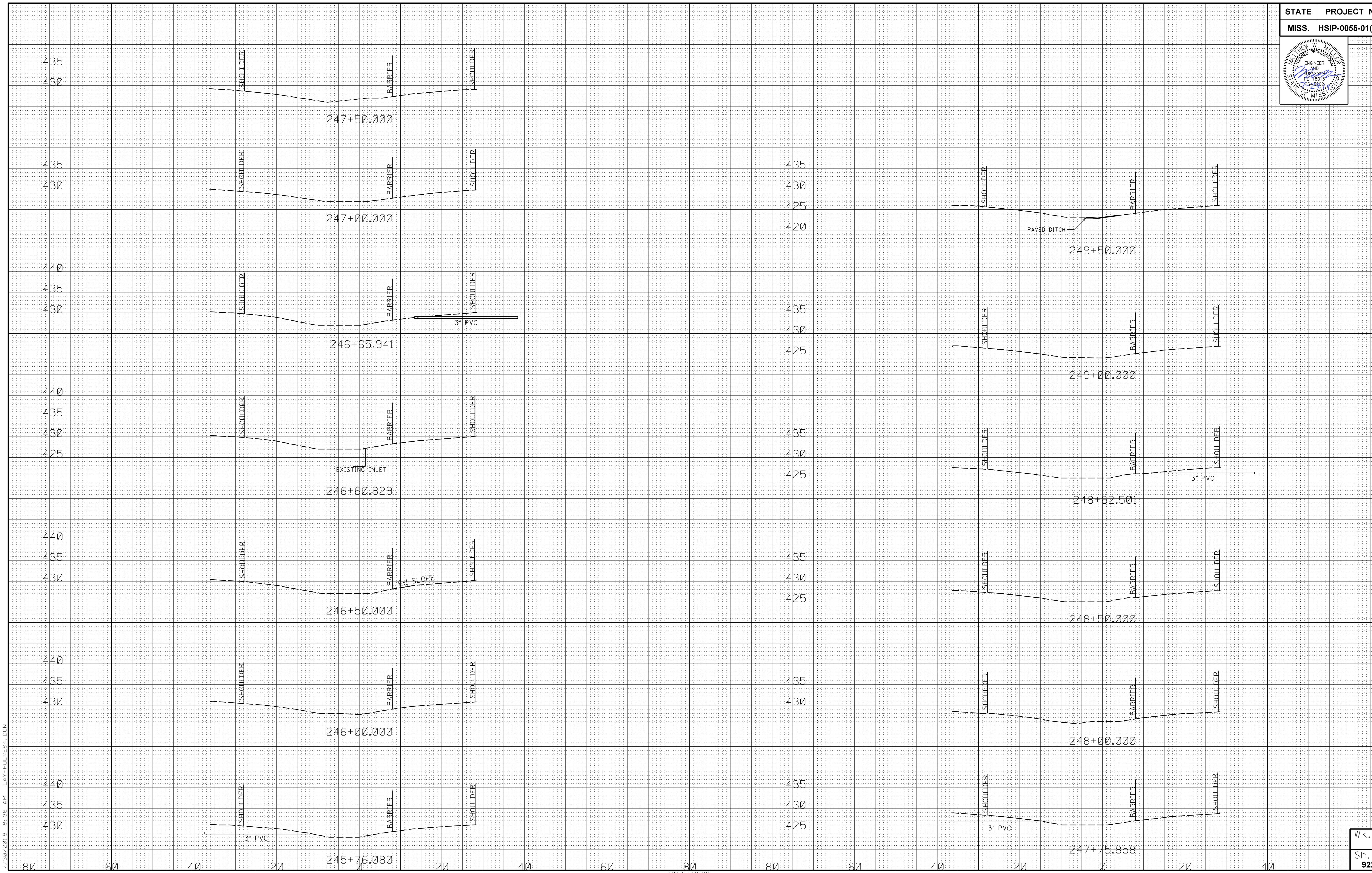
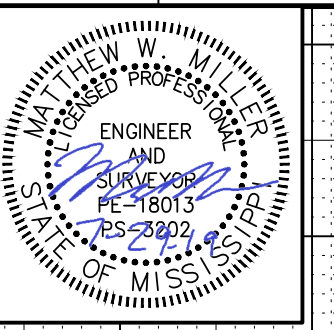

7/30/2019 8:36 AM LAY-HOLMES4.DGN

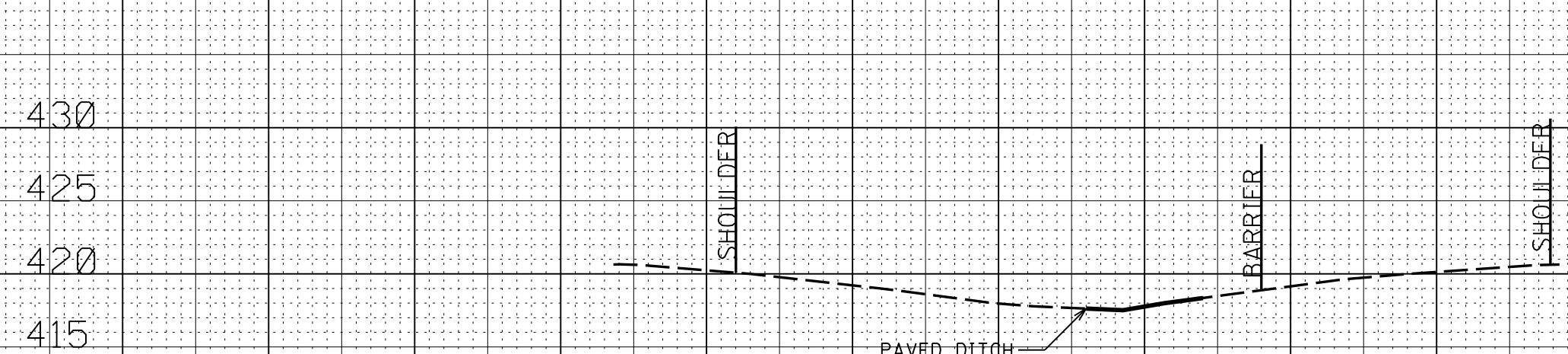
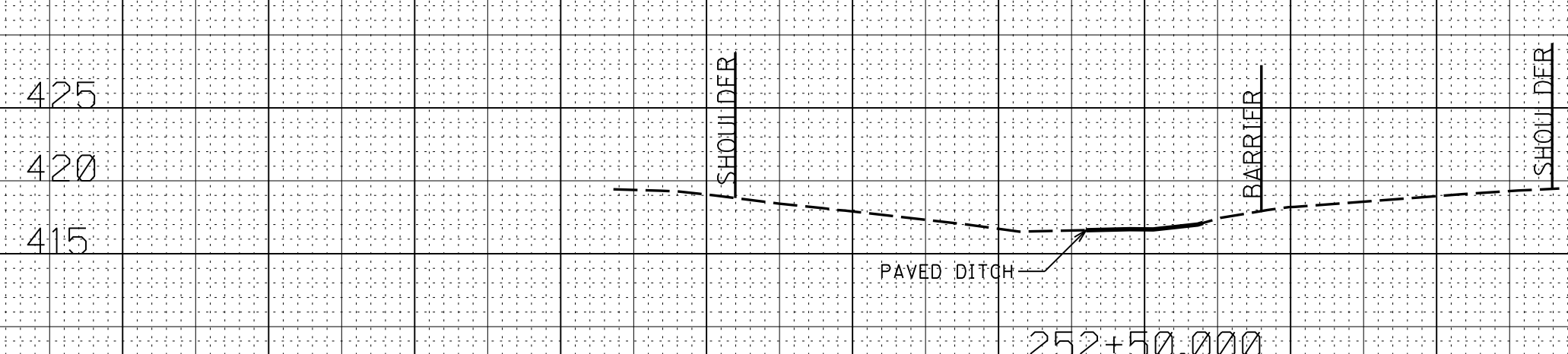
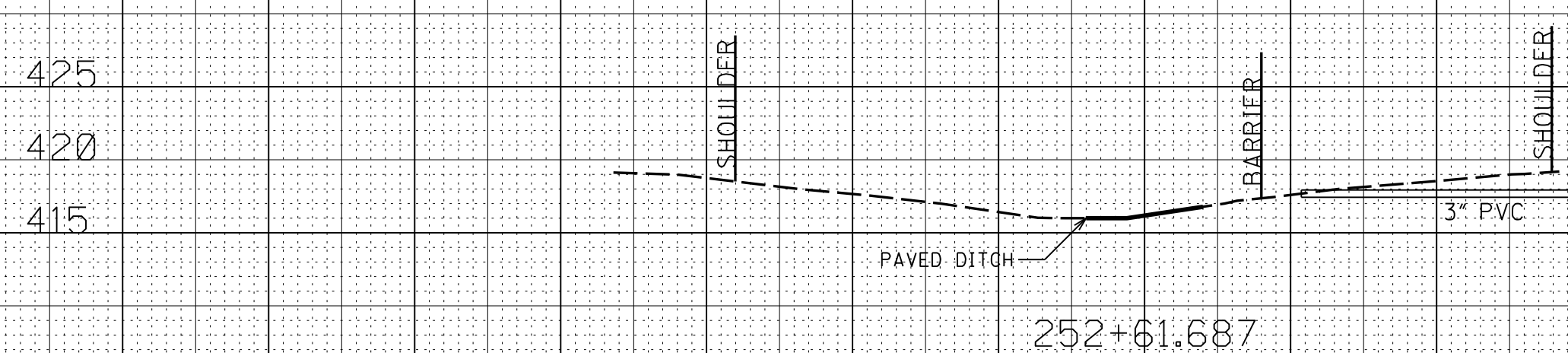
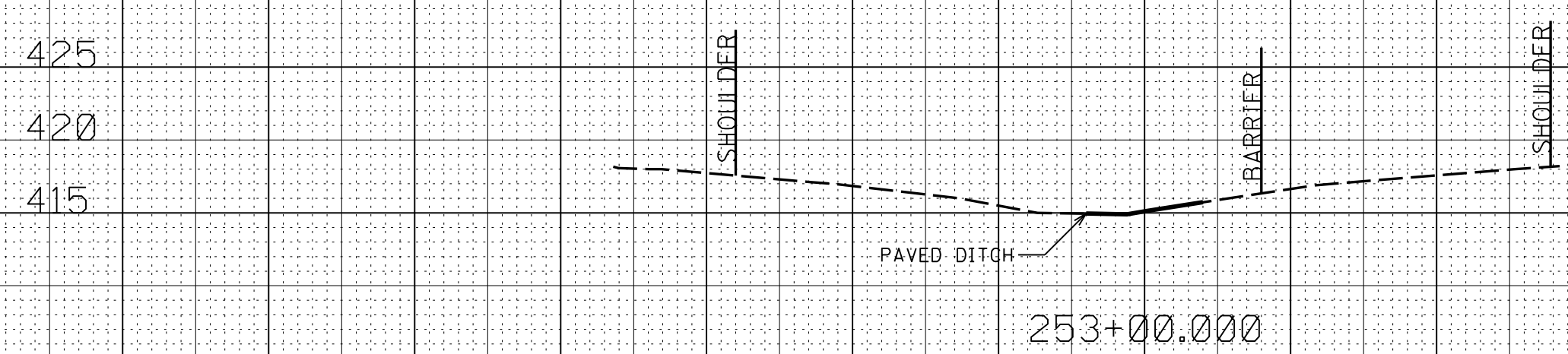
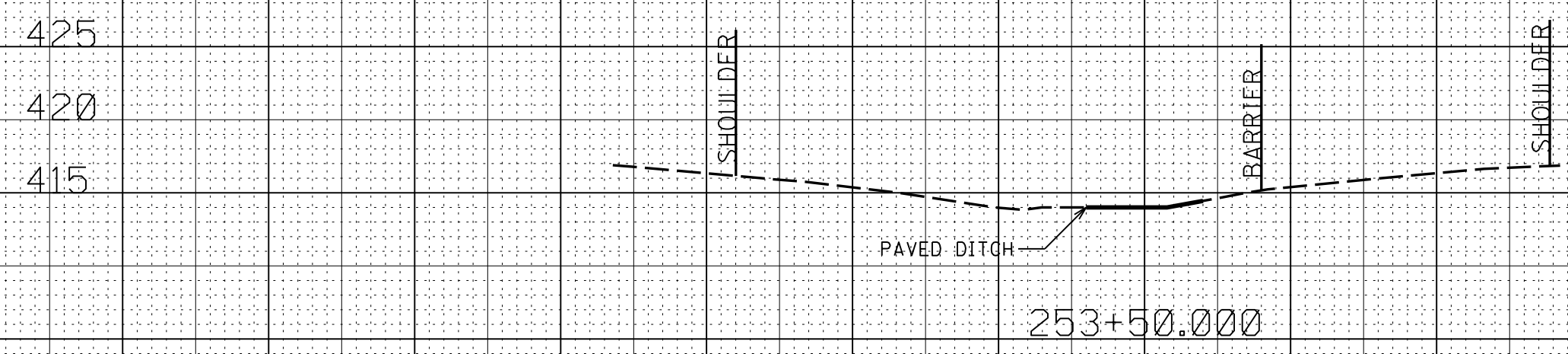
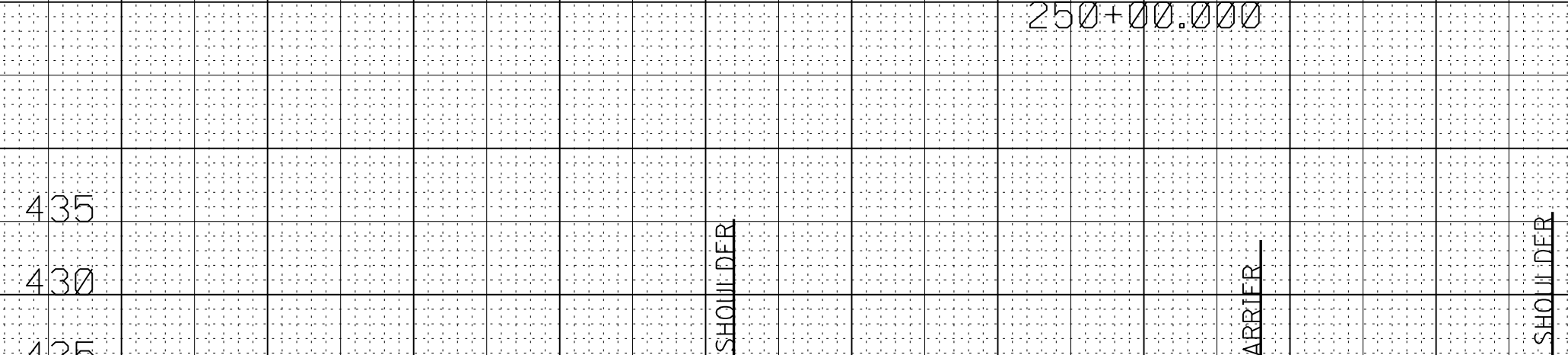
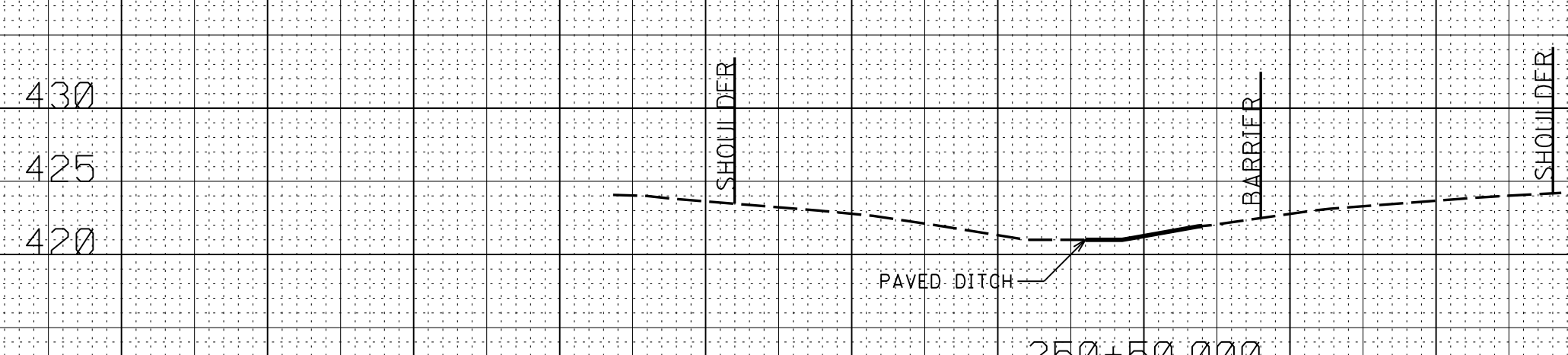
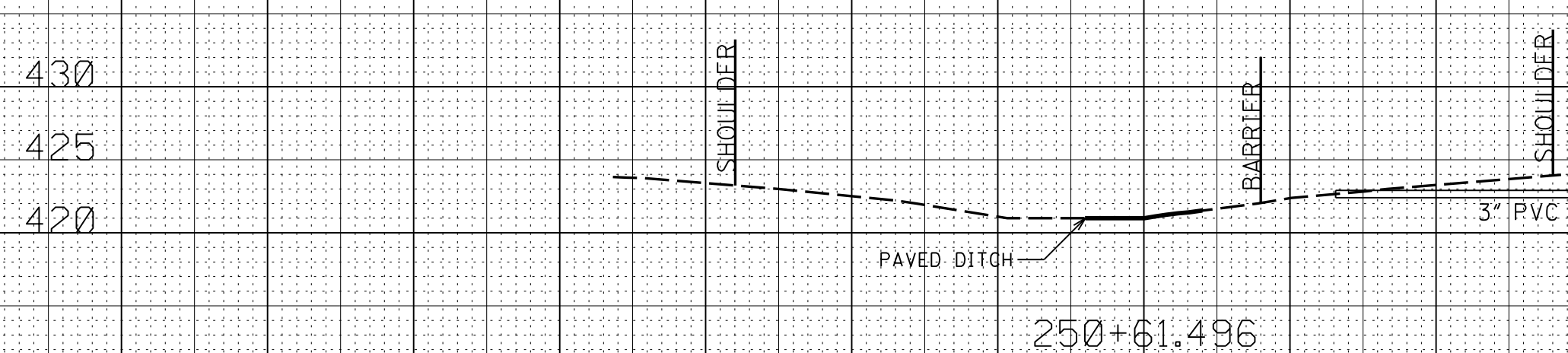
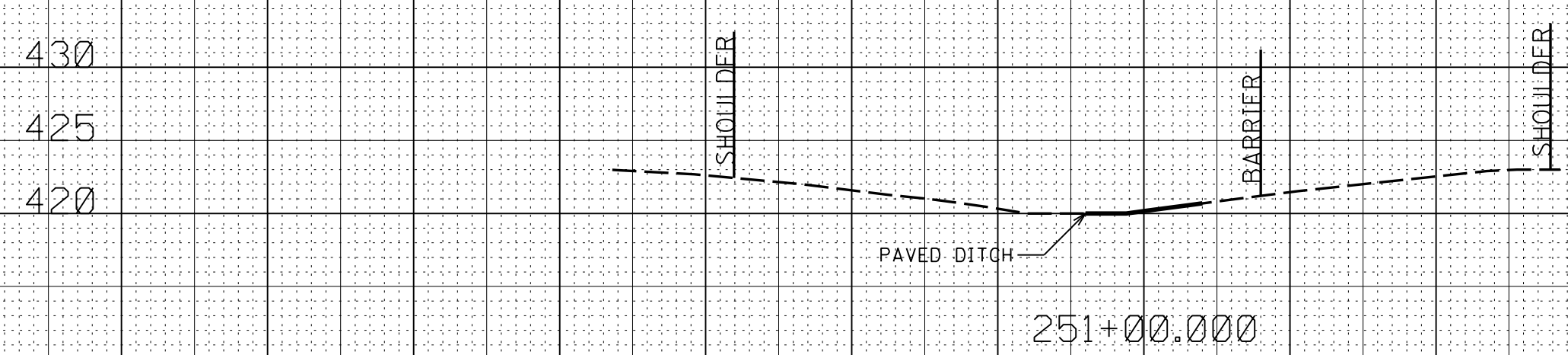
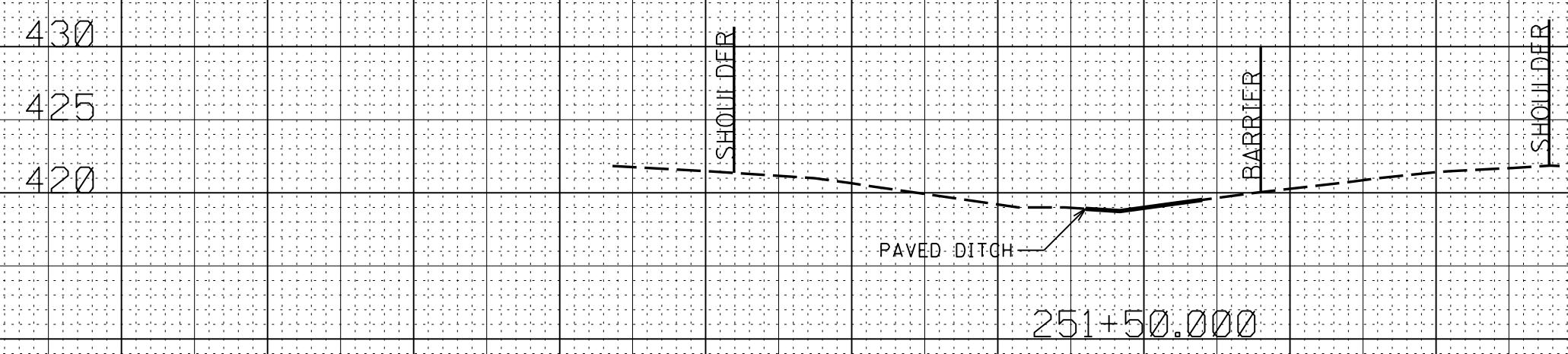
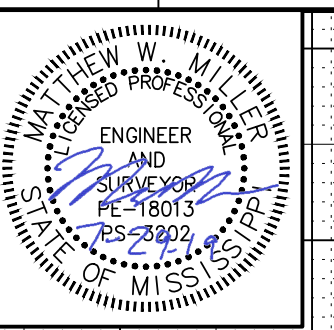

7/30/2019 8:36 AM LAY-HOLMES4.DGN

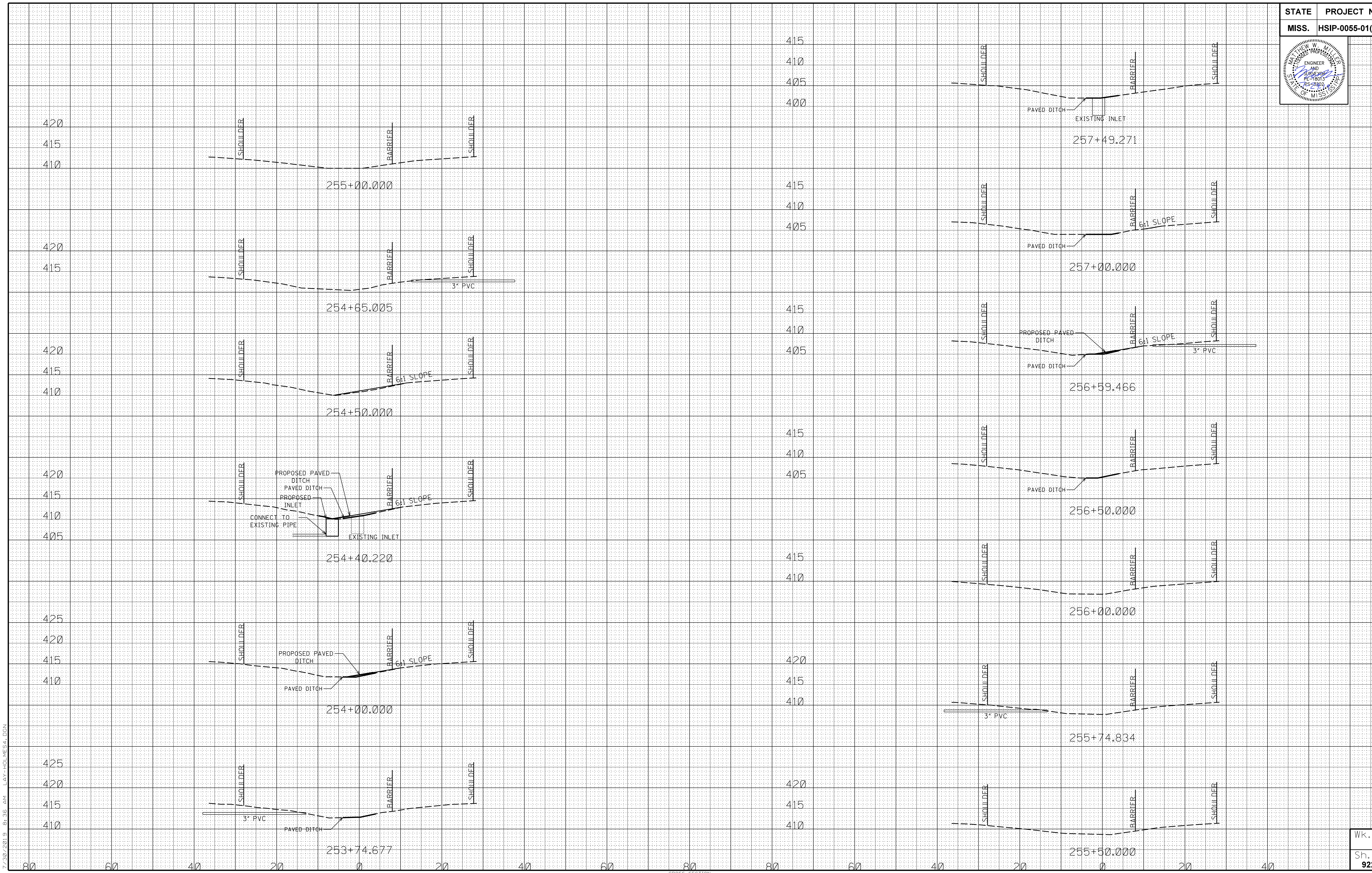
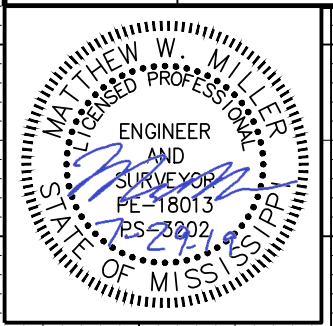

7/30/2019 8:36 AM LAY-HOLMES4.DGN

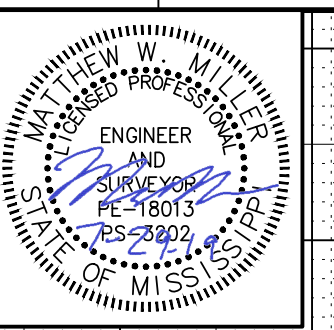

7/30/2019 8:36 AM LAY-HOLMES4.DGN

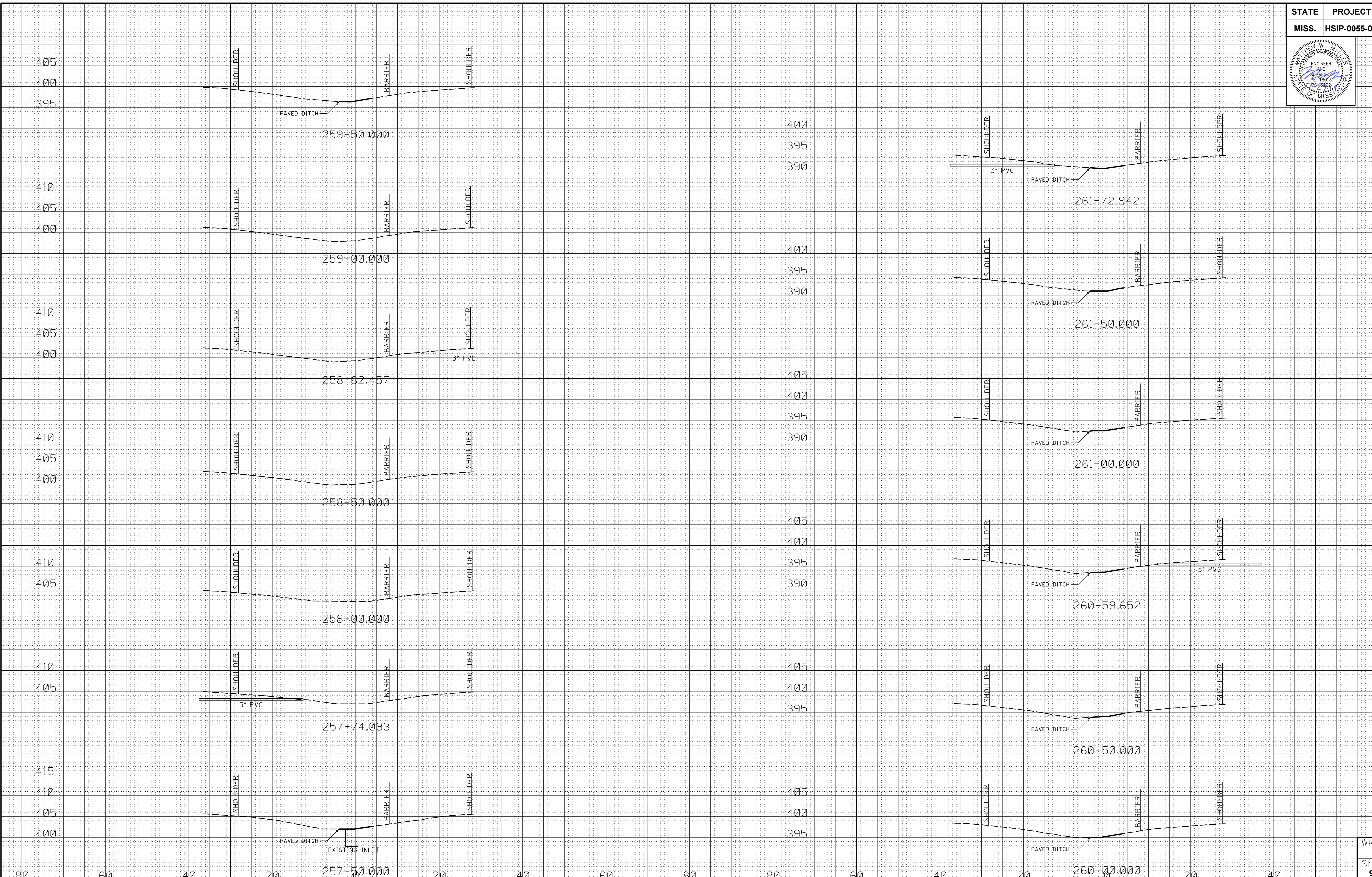

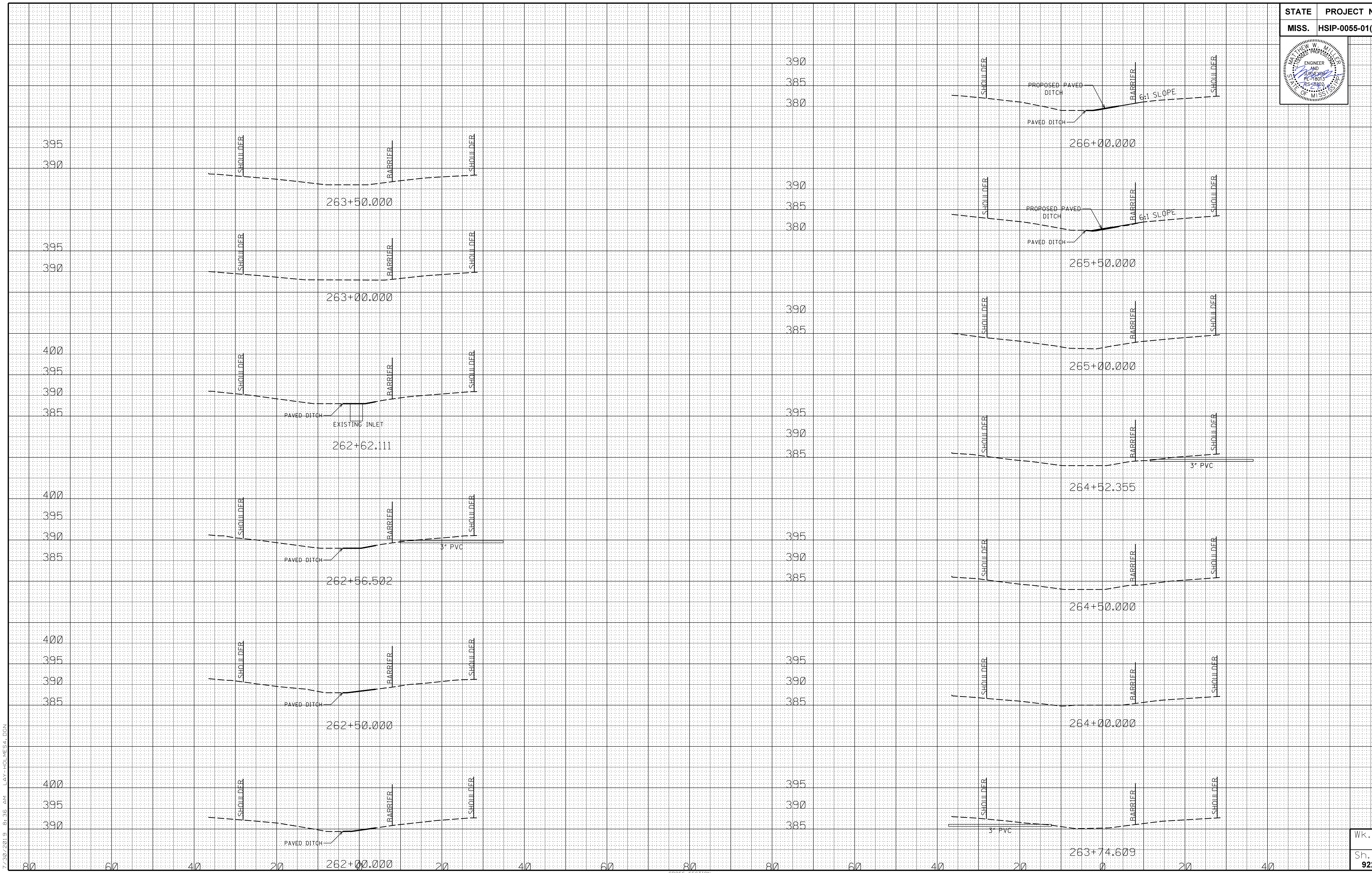
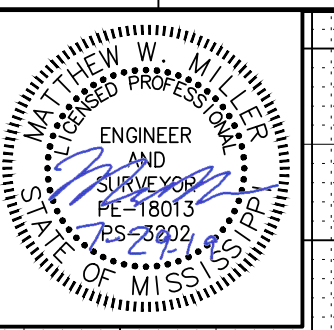

7/30/2019 8:36 AM LAY-HOLMES4.DGN

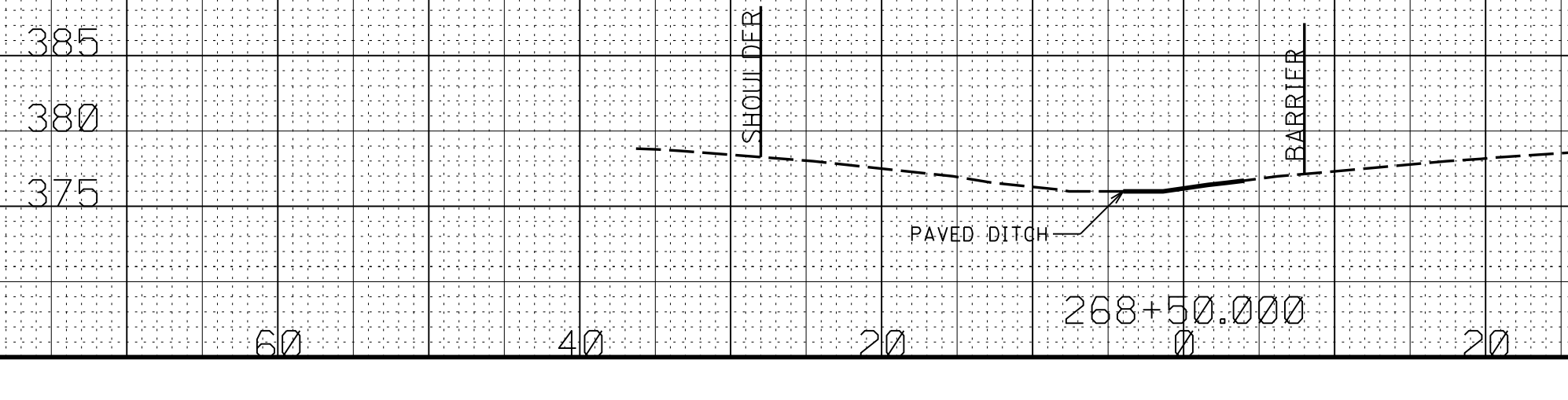
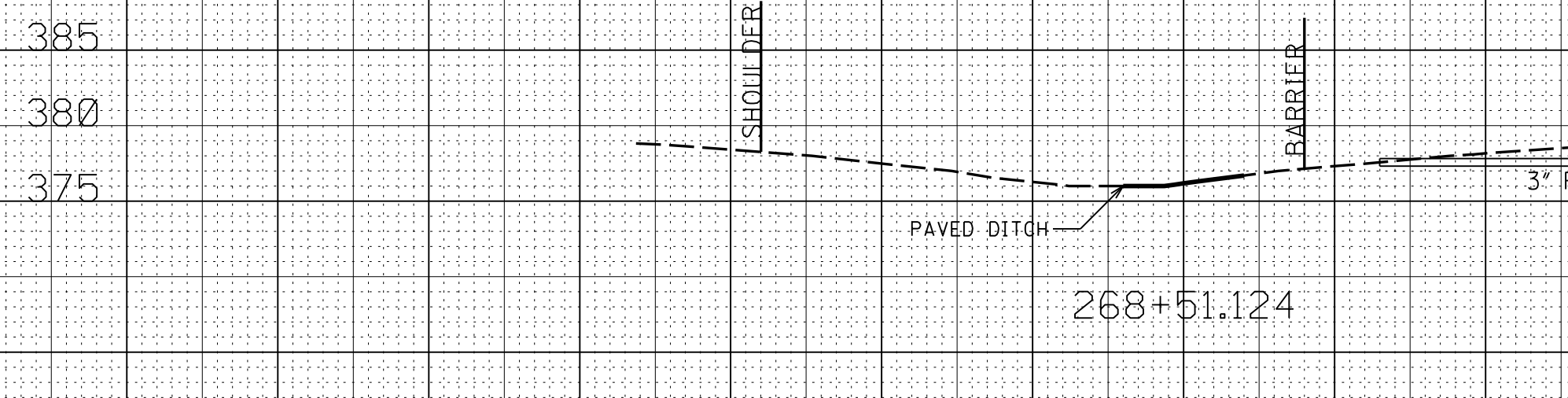
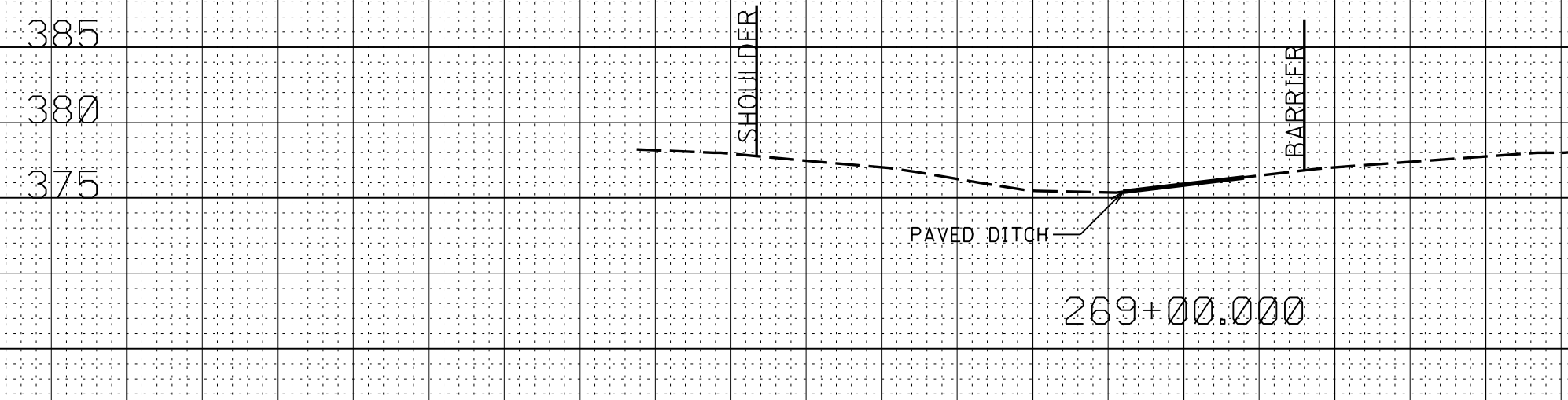
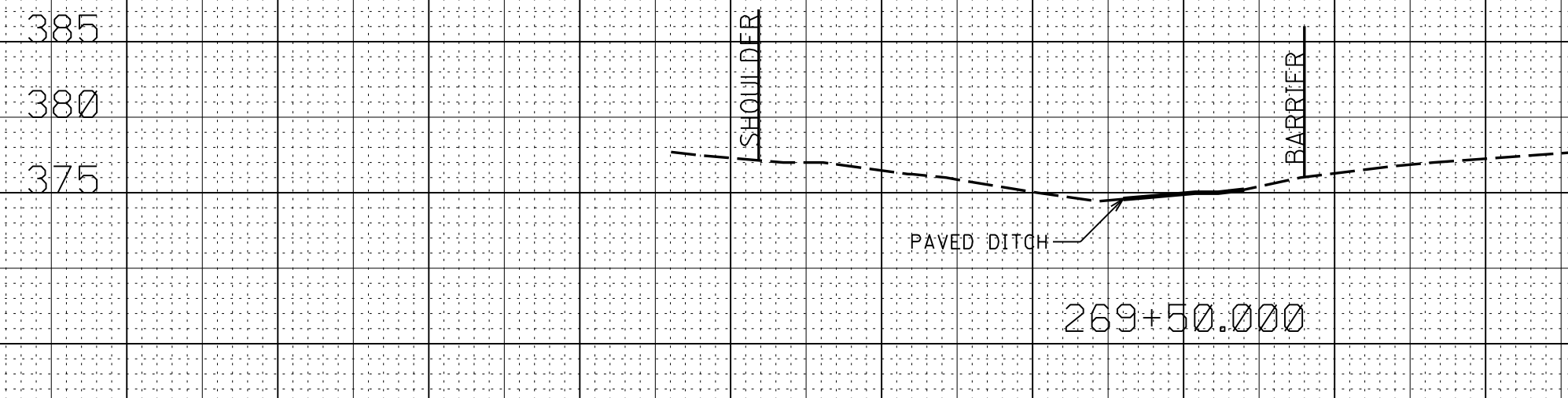
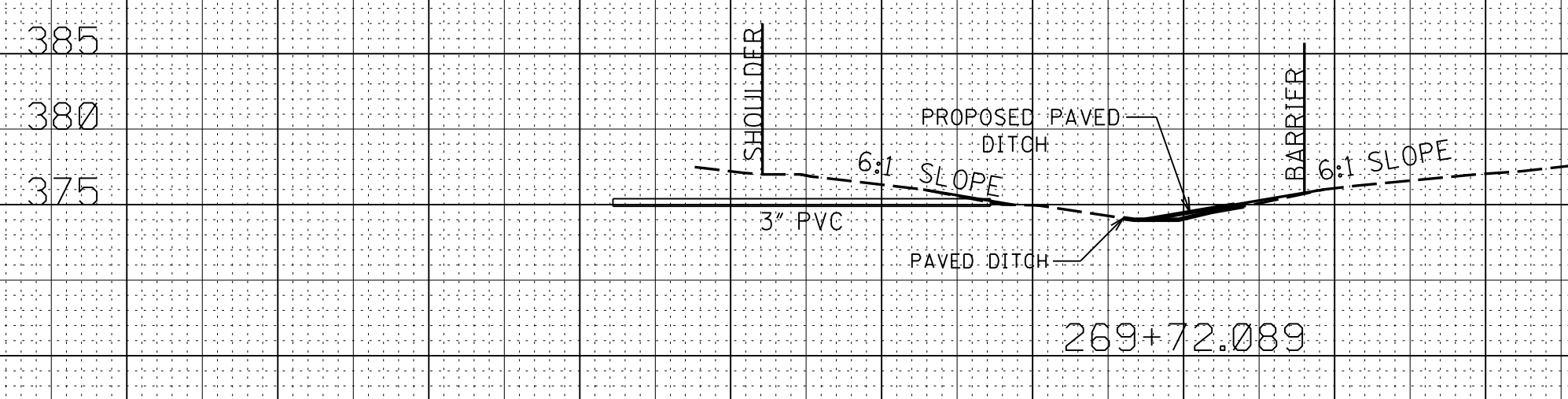
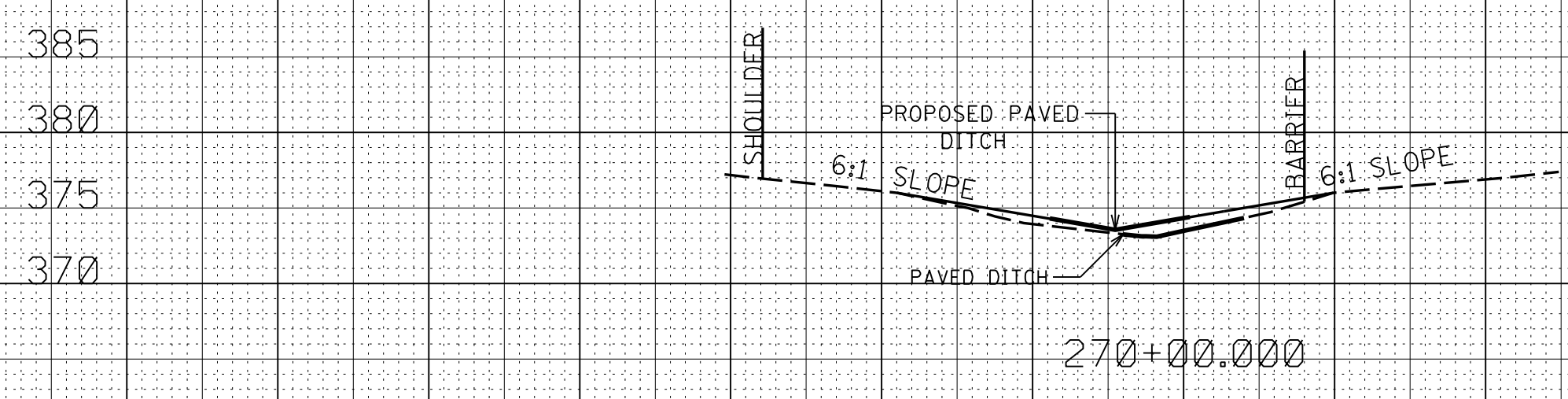
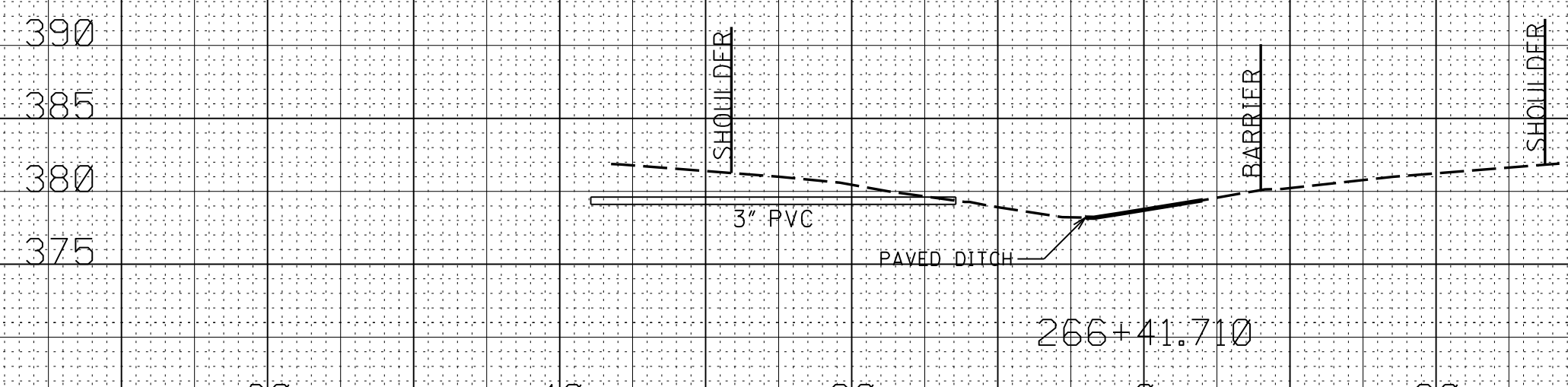
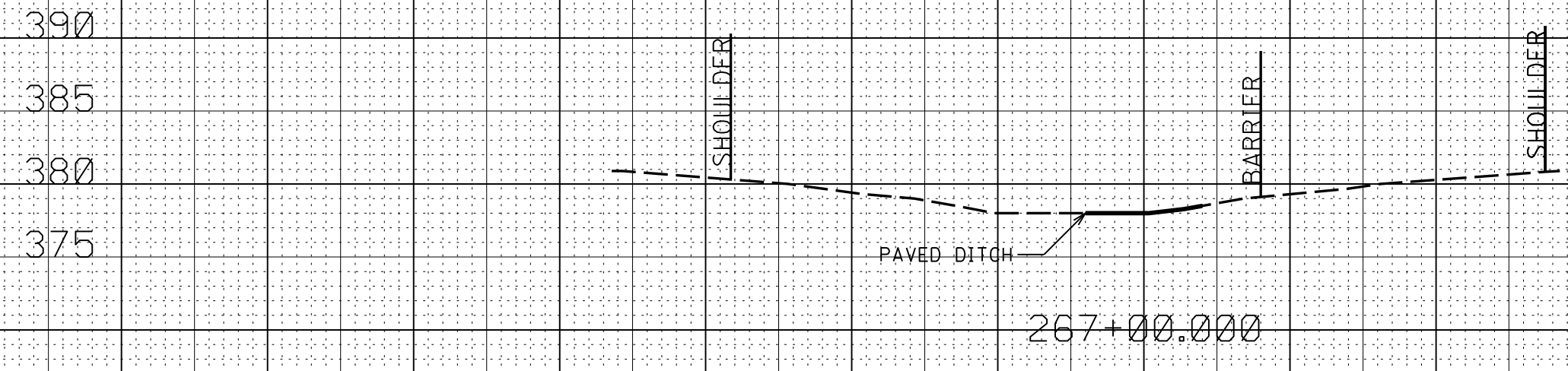
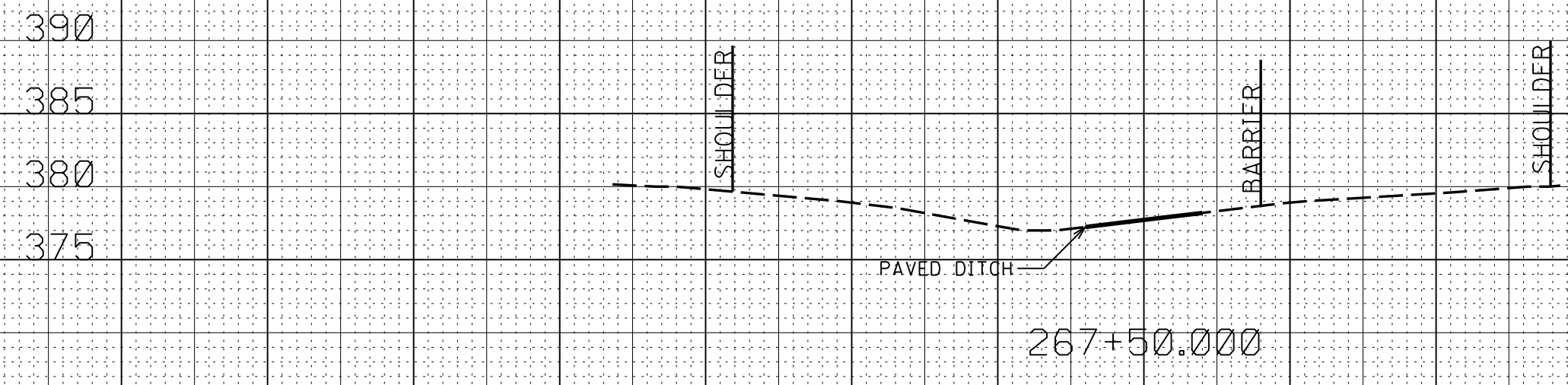
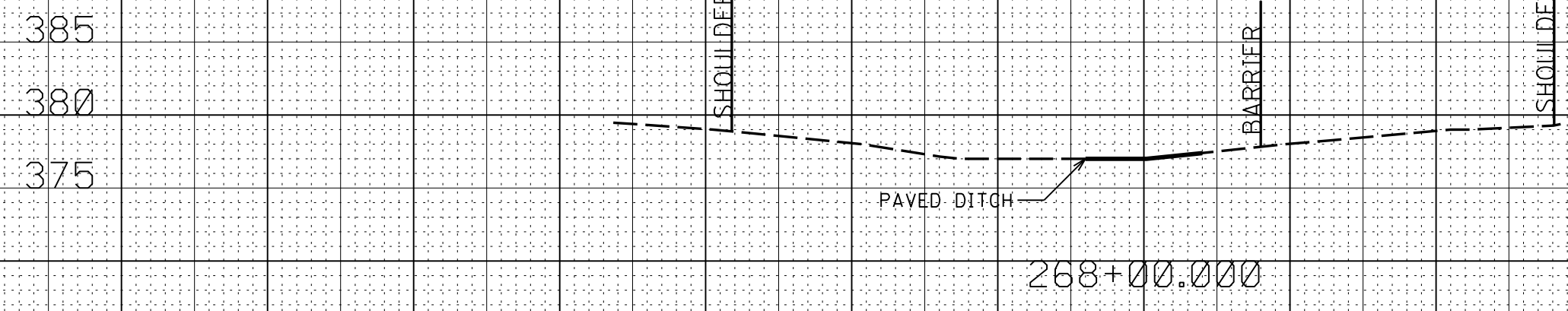
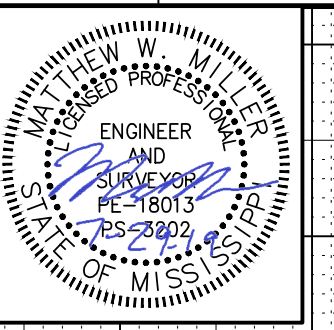

7/30/2019 8:36 AM LAY-HOLMES4.DGN

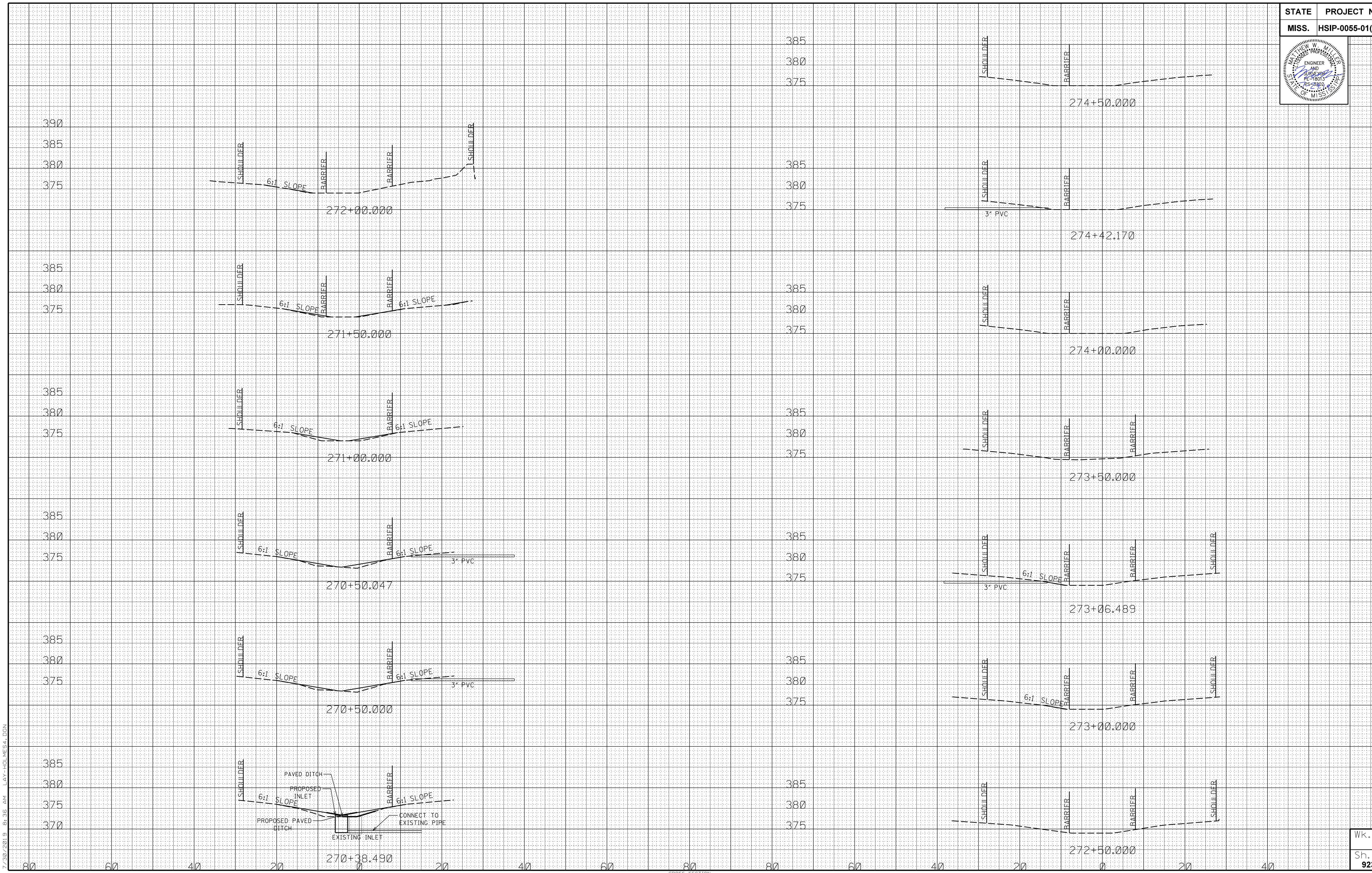
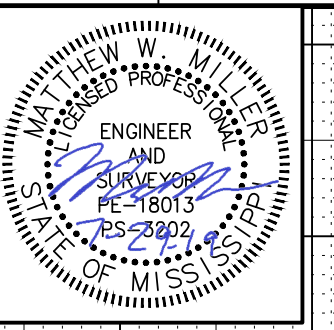

7/30/2019 8:36 AM LAY-HOLMES4.DGN

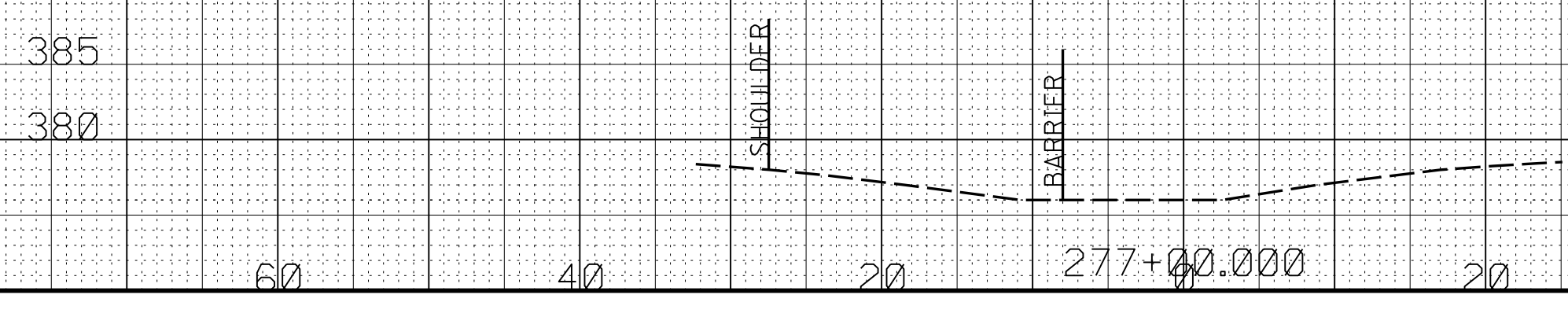
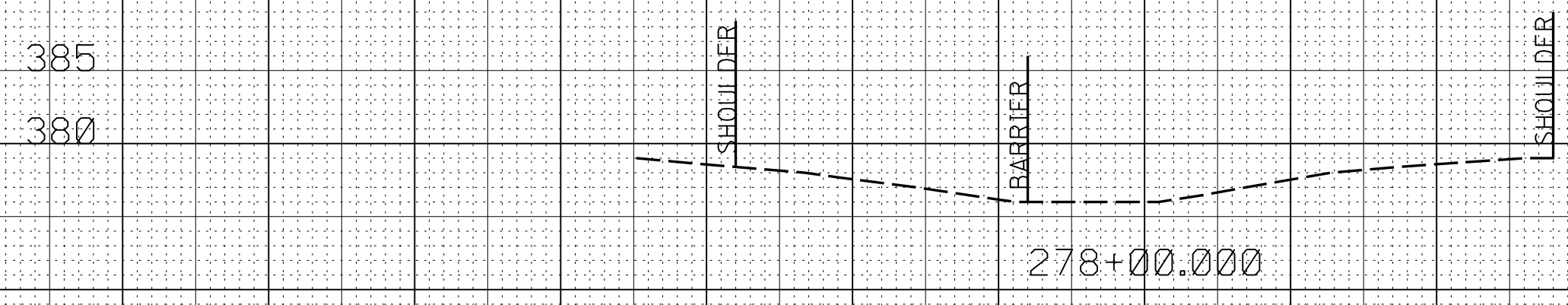
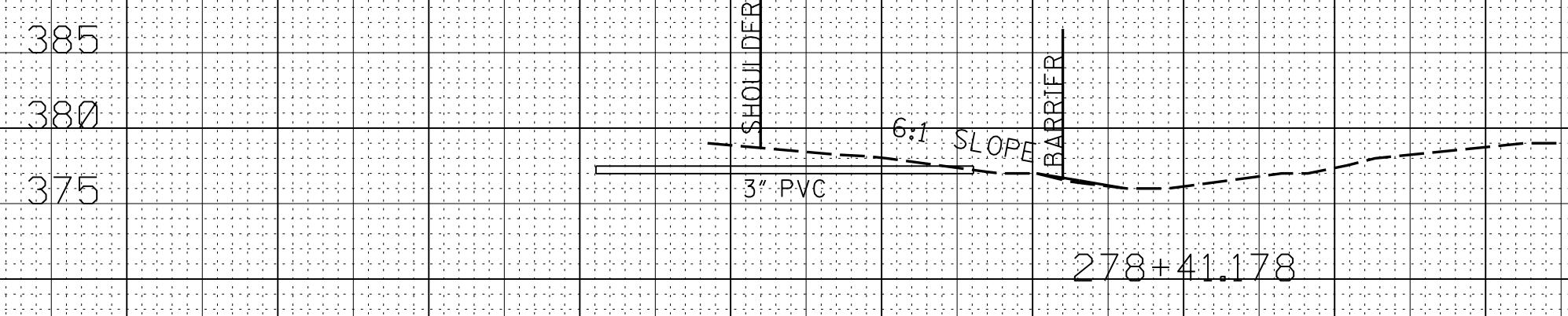
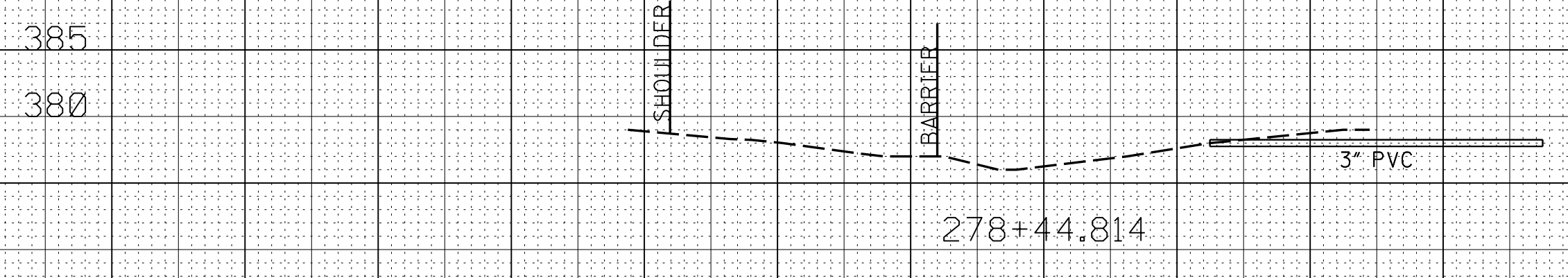
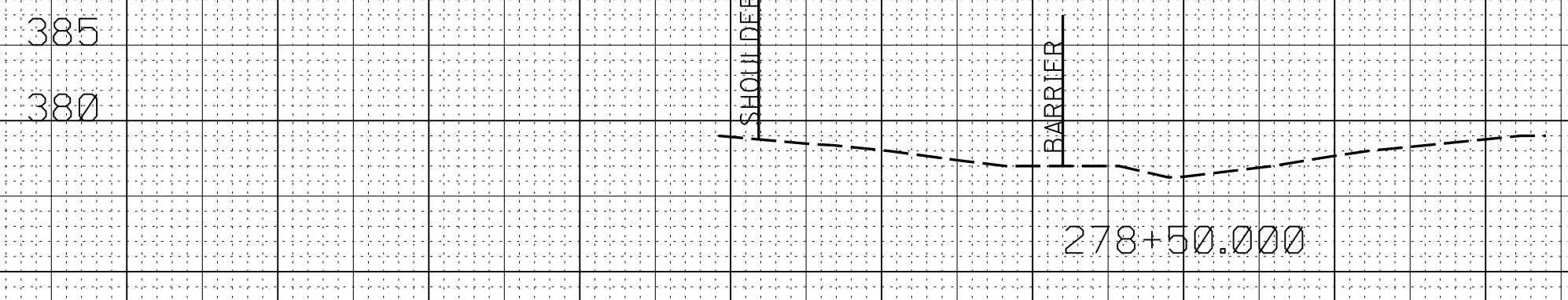
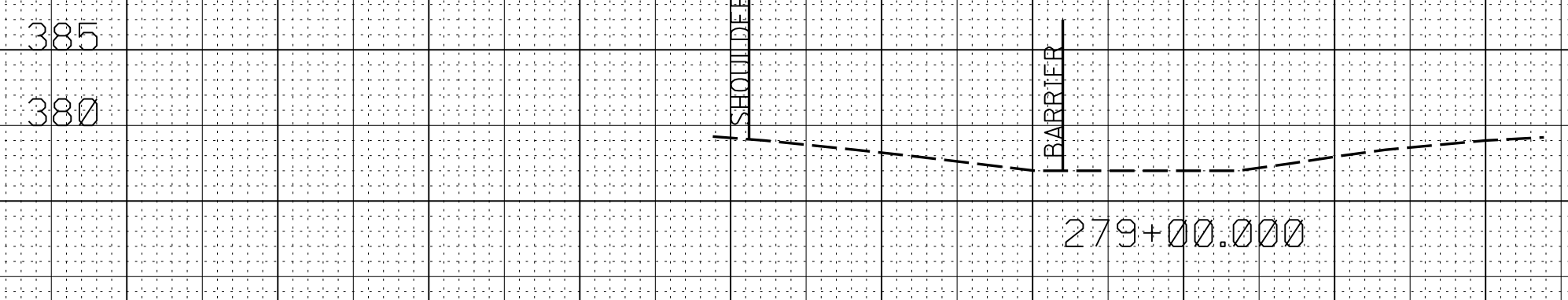
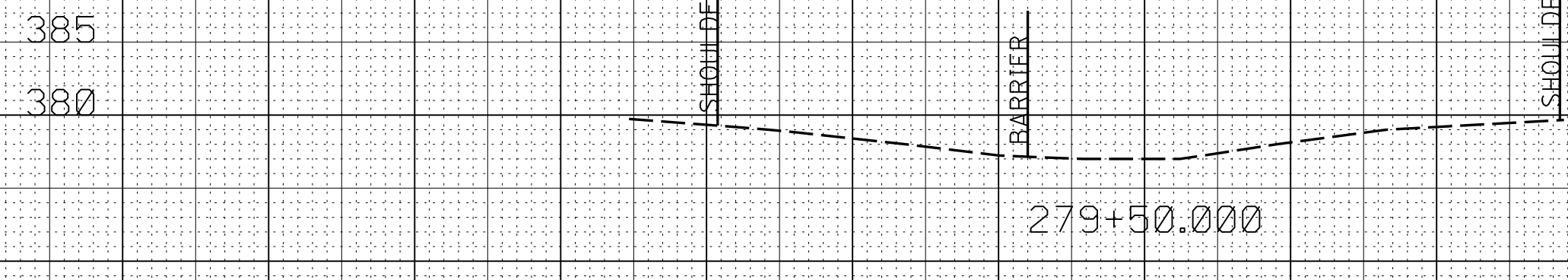
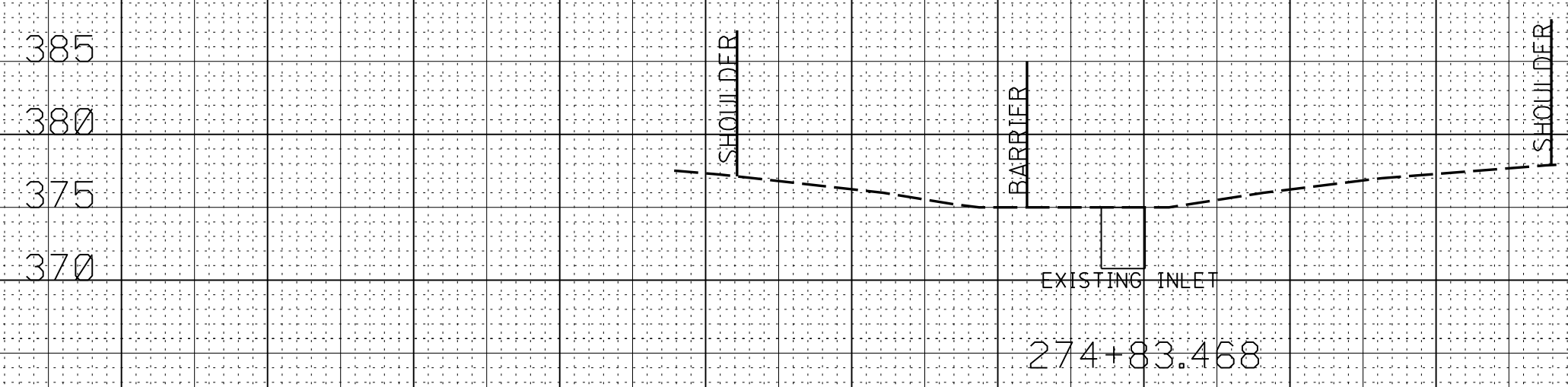
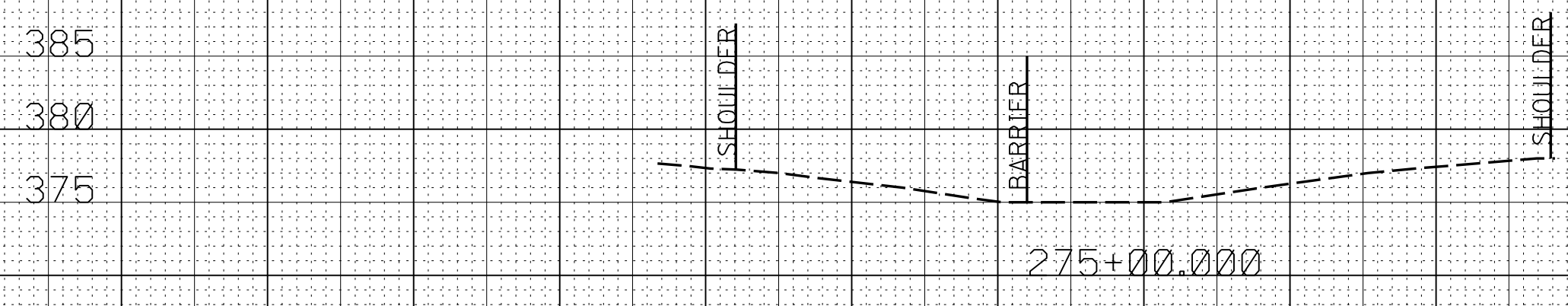
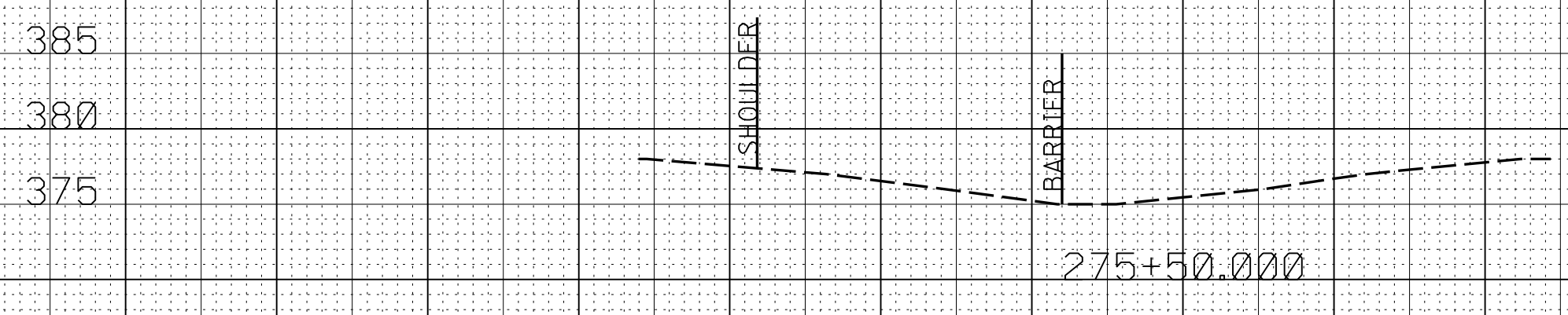
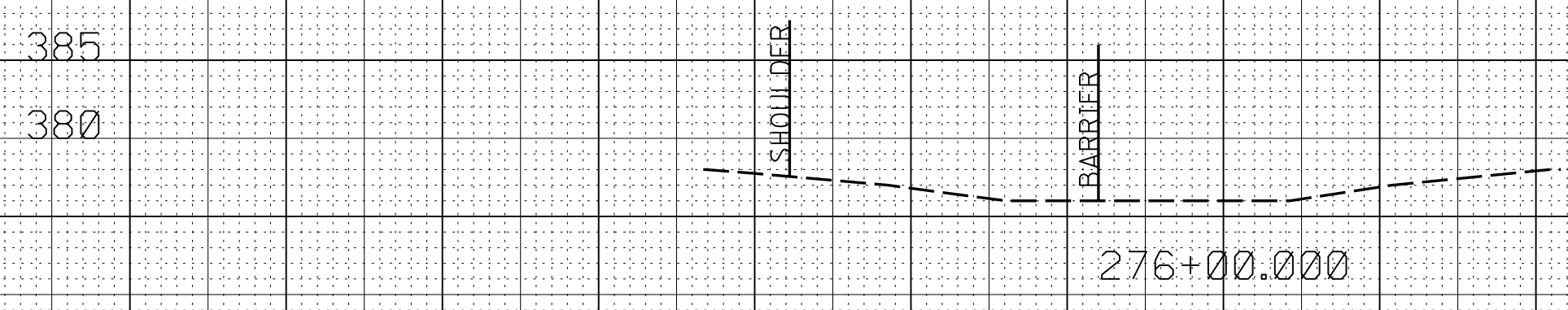
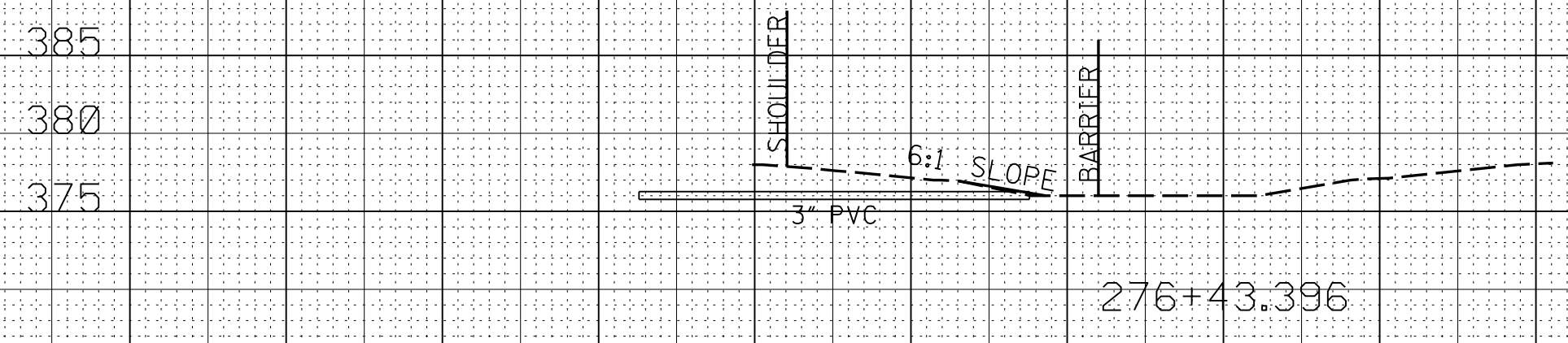
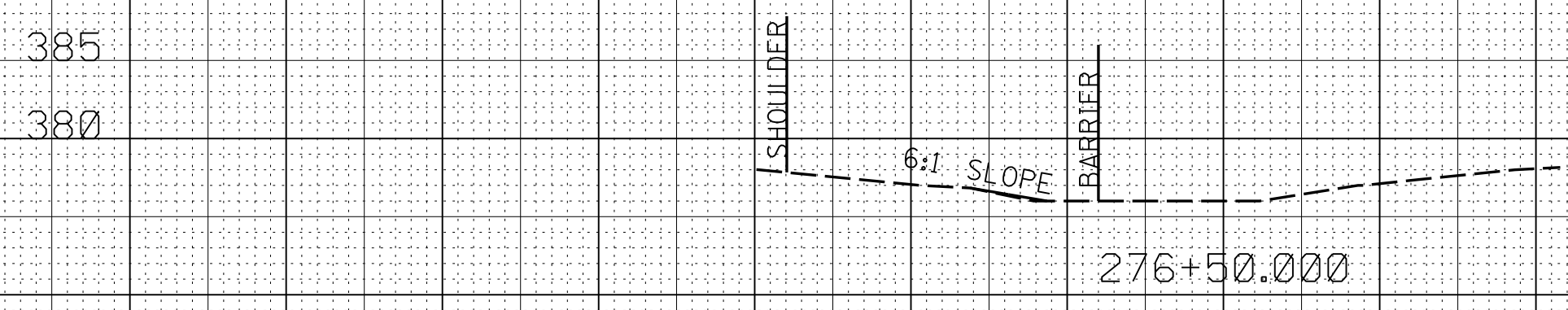
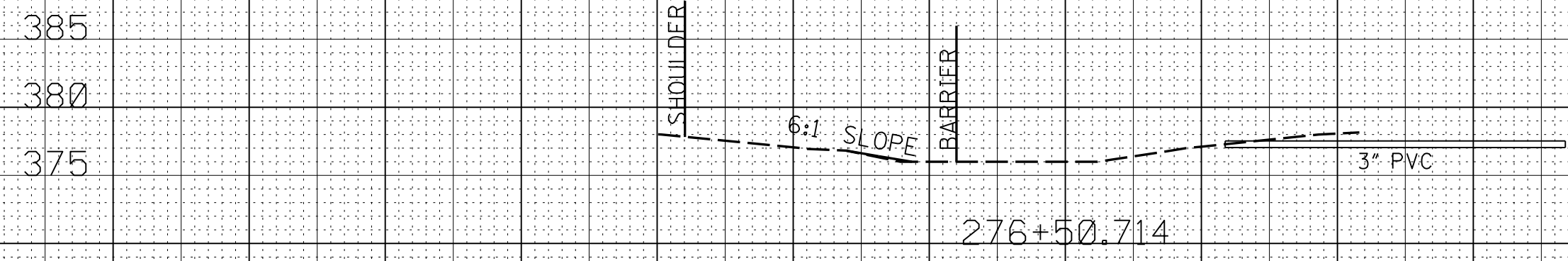
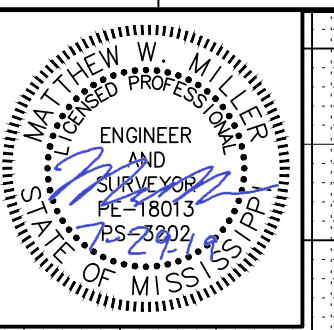

7/26/2019 8:36 AM LAY-HOLMES4.DGN

80 60 40 20 0 20 40 60 80 80 60 40 20 40

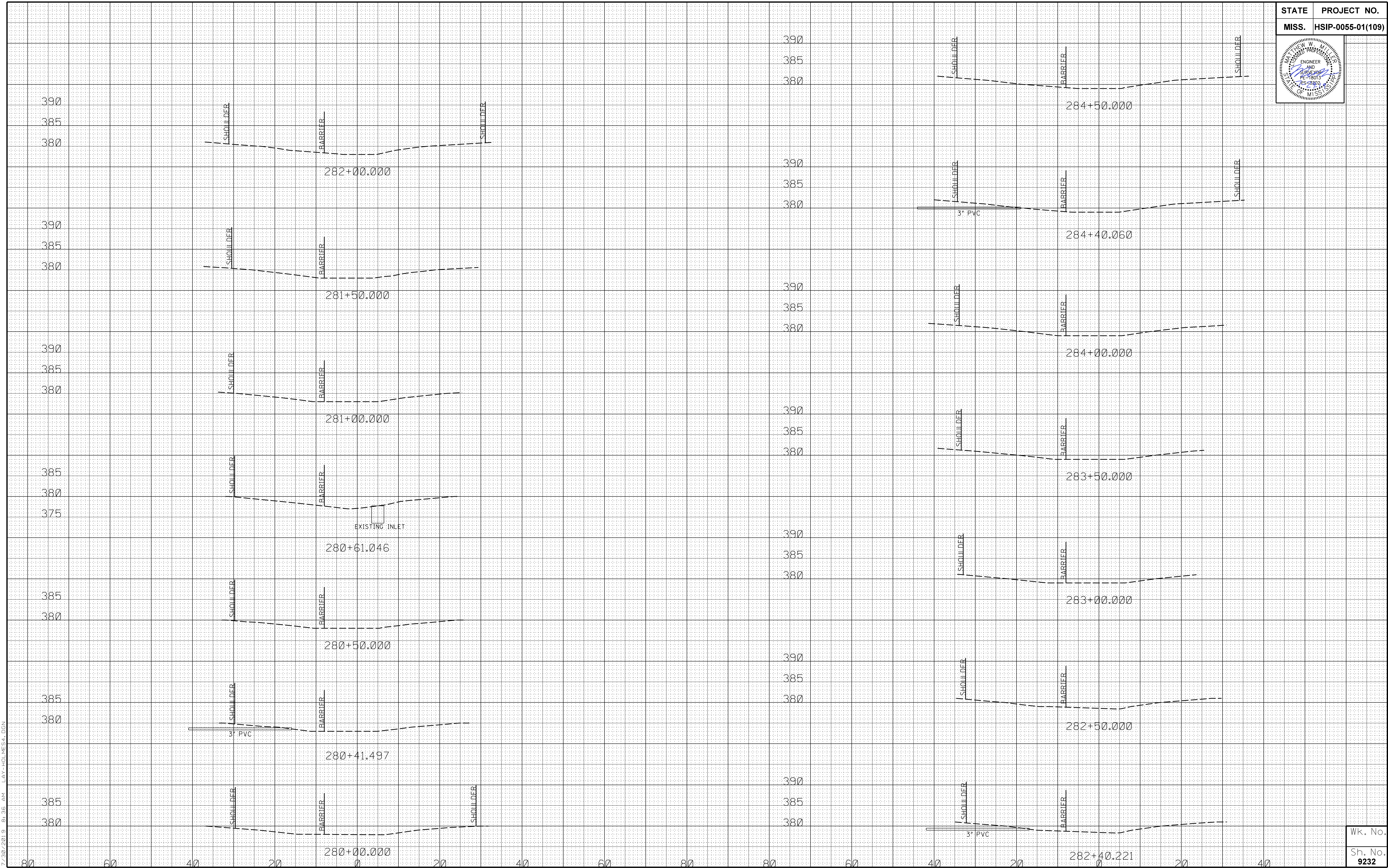
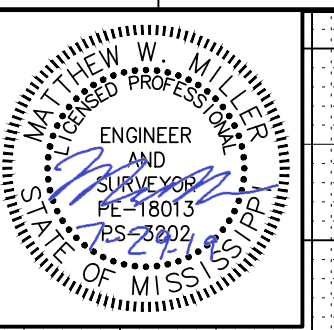

7/30/2019 8:36 AM LAY-HOLMES4.DGN

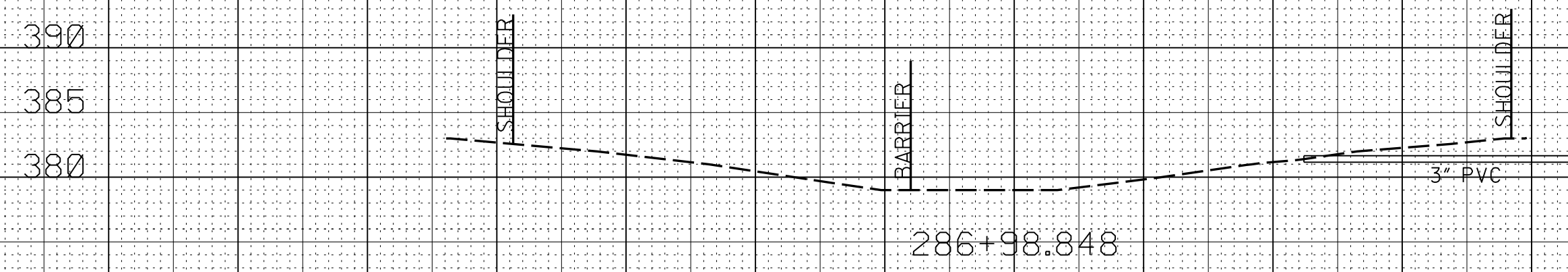
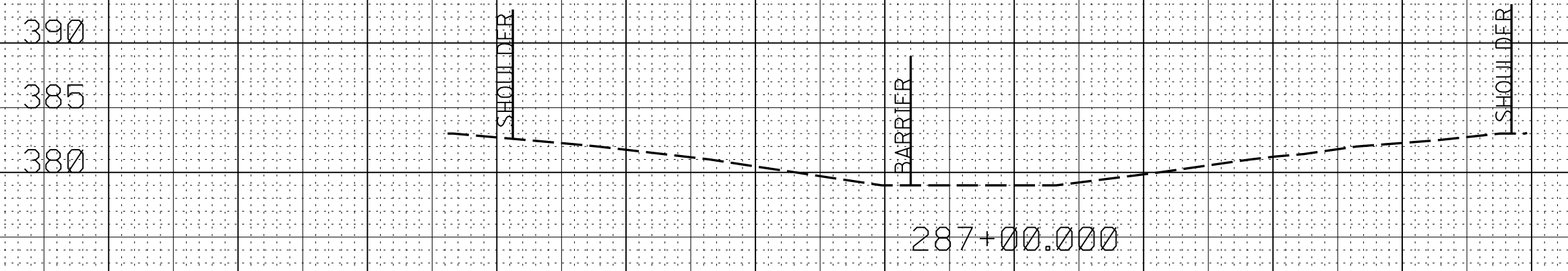
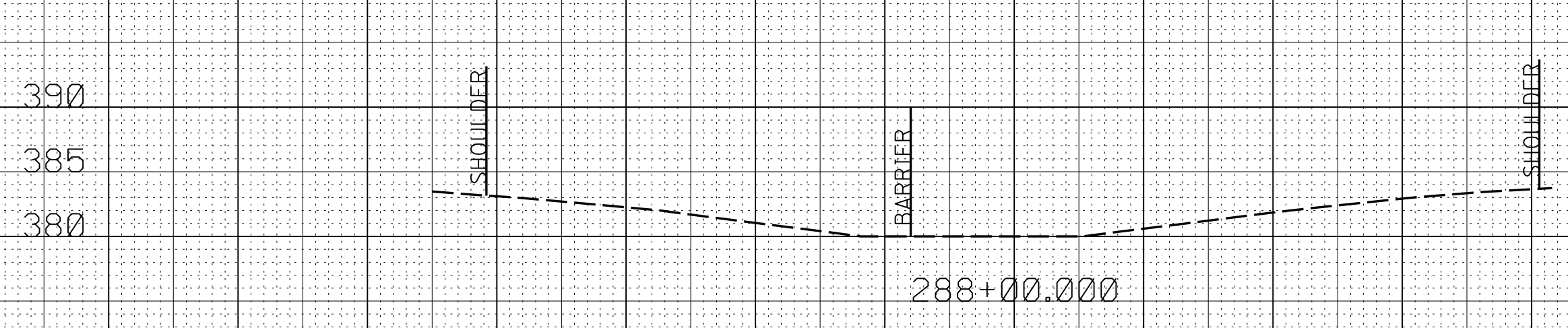
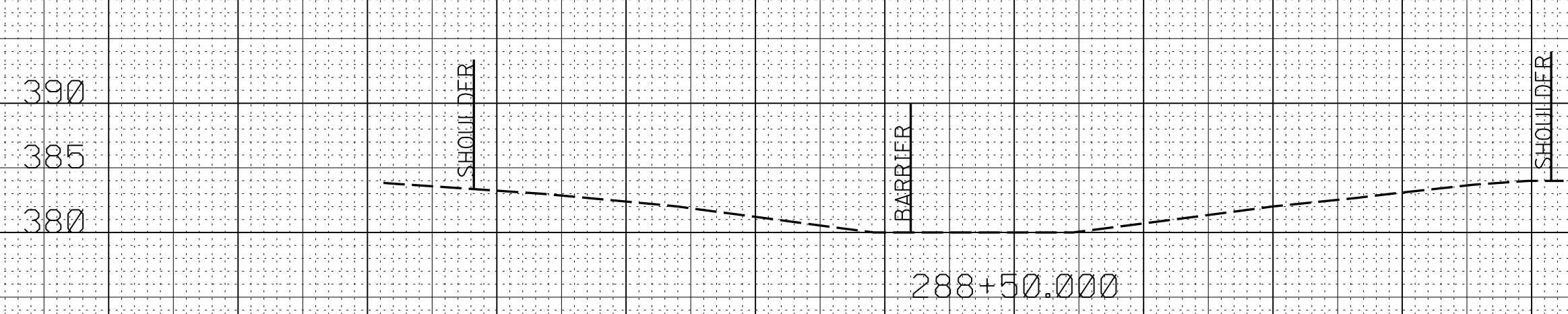
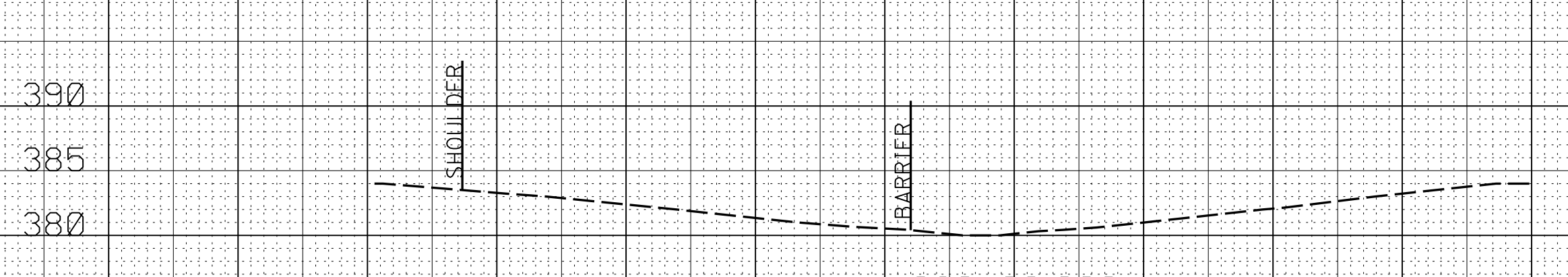
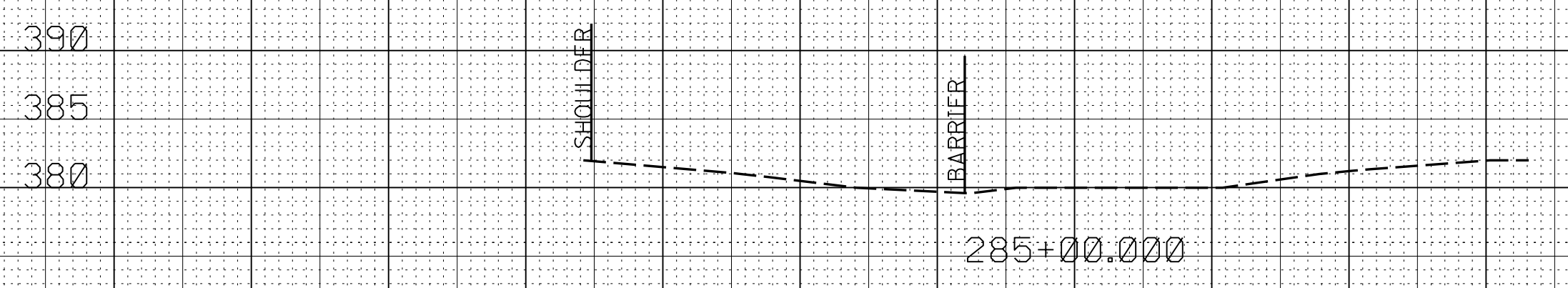
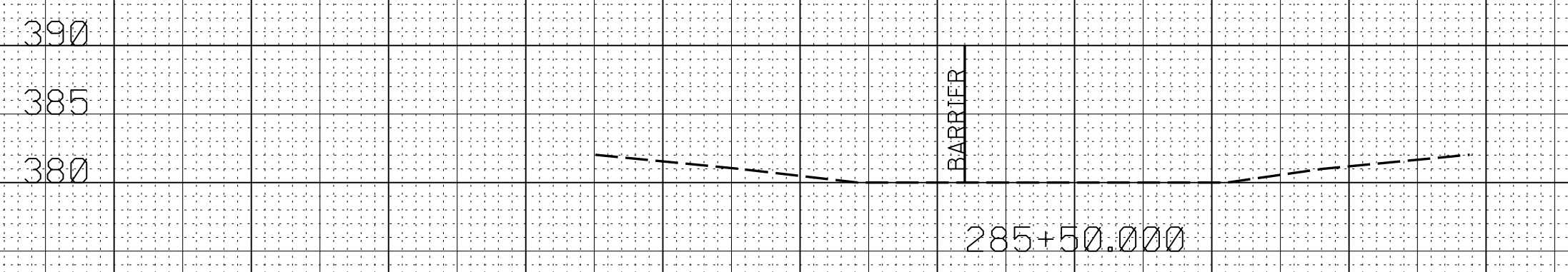
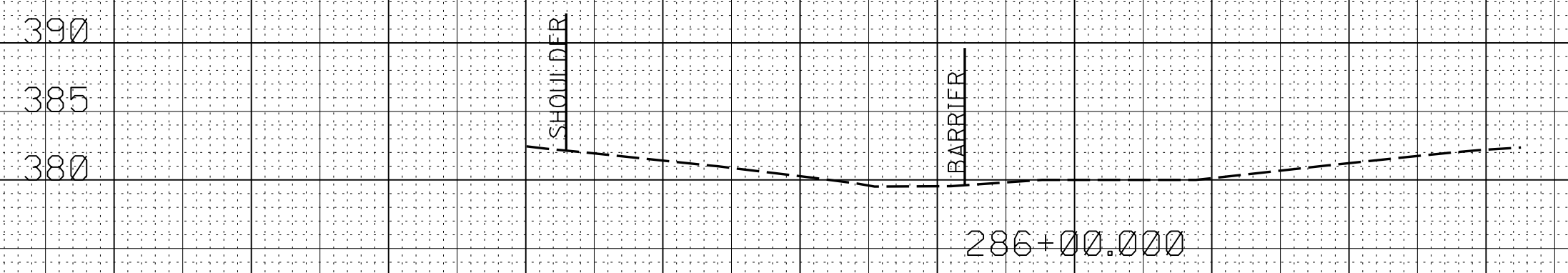
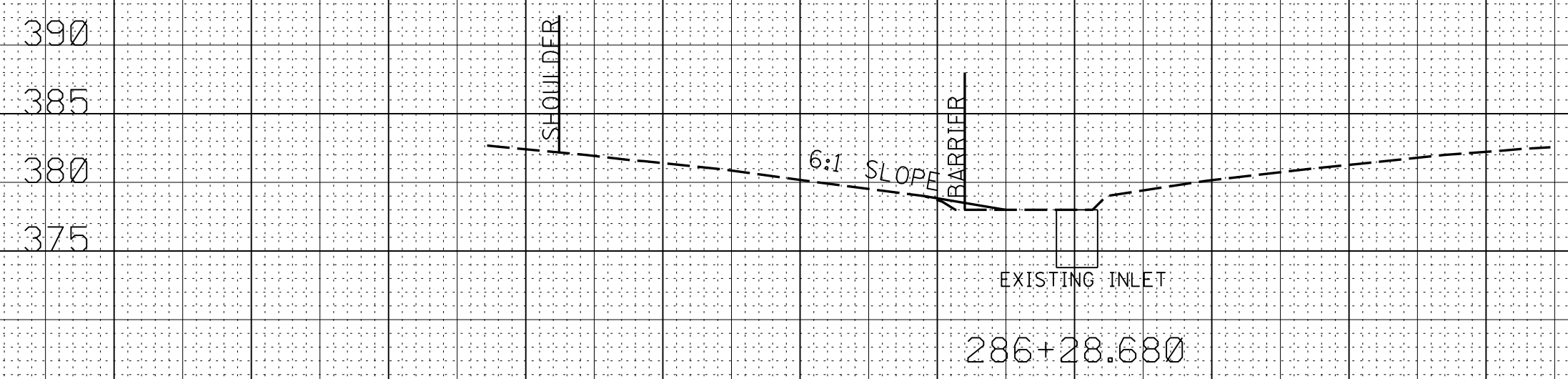
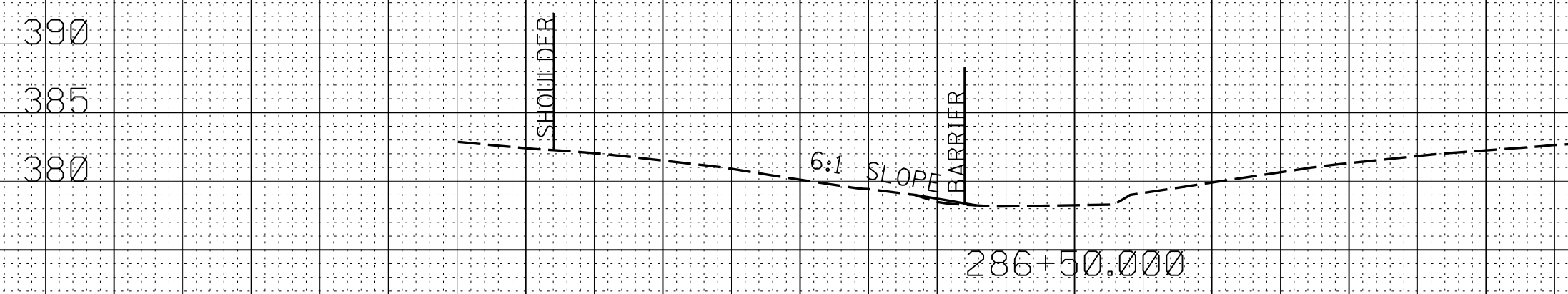
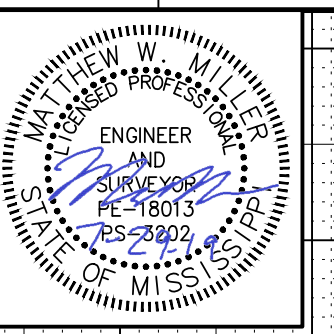

7/30/2019 8:36 AM LAY-HOLMES4.DGN

80 60 40 20 0 20 40 60 80 80 60 40 20 0 20 40

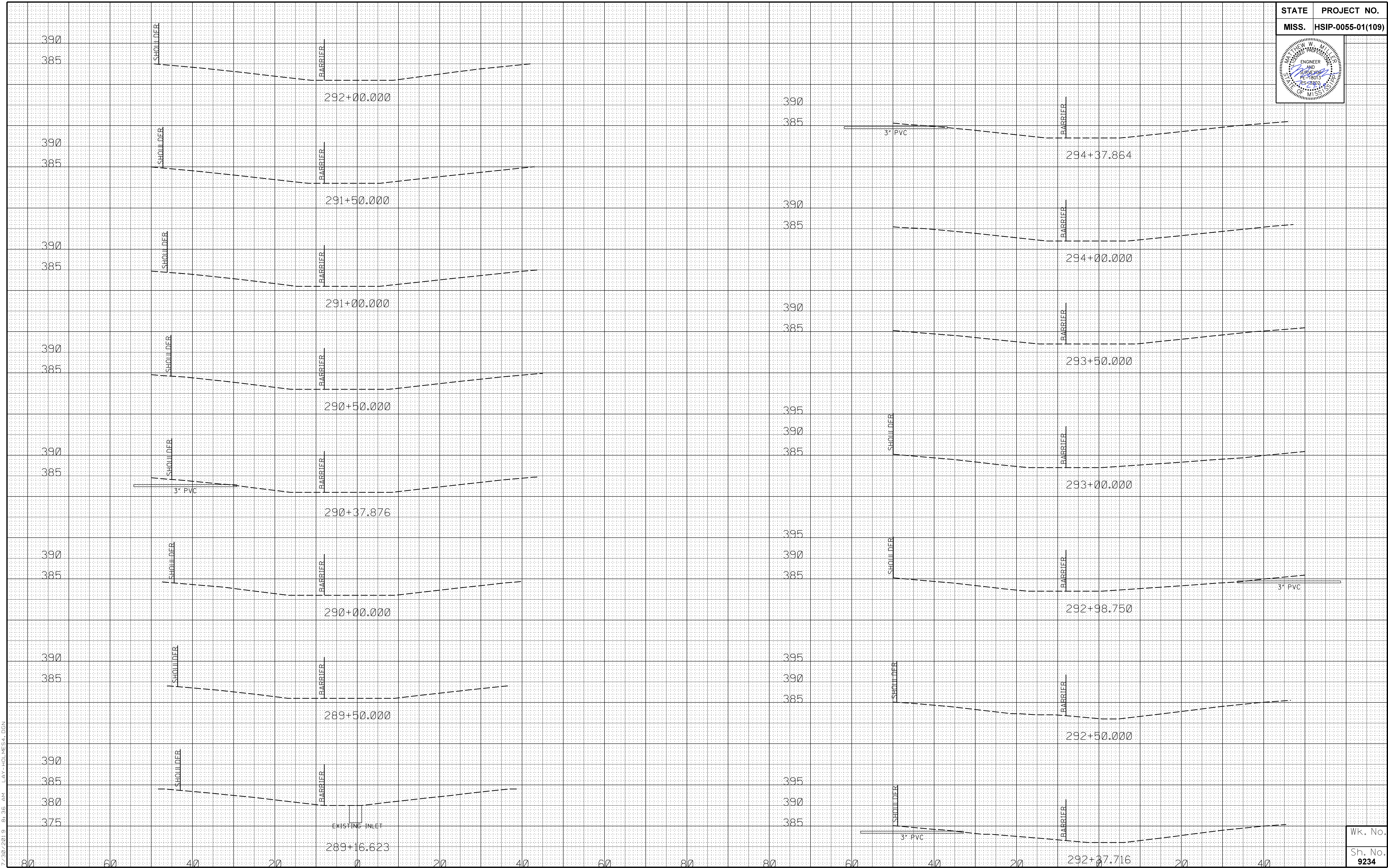
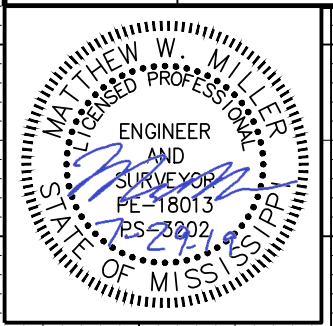

7/20/2019 8:36 AM LAY-HOLMES4.DGN

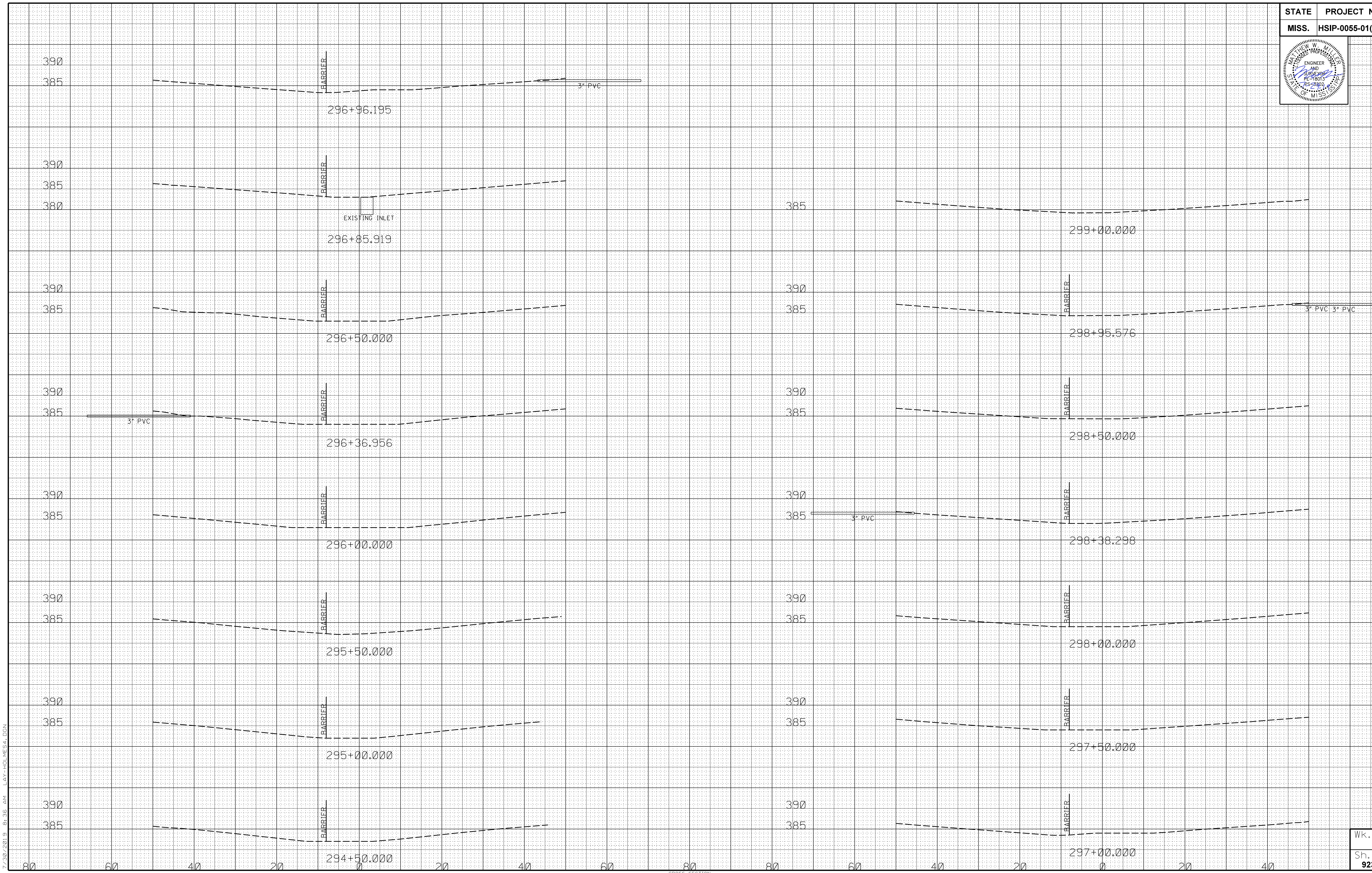
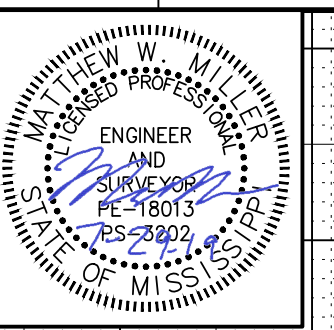

7/30/2019 8:36 AM LAY-HOLMES4.DGN

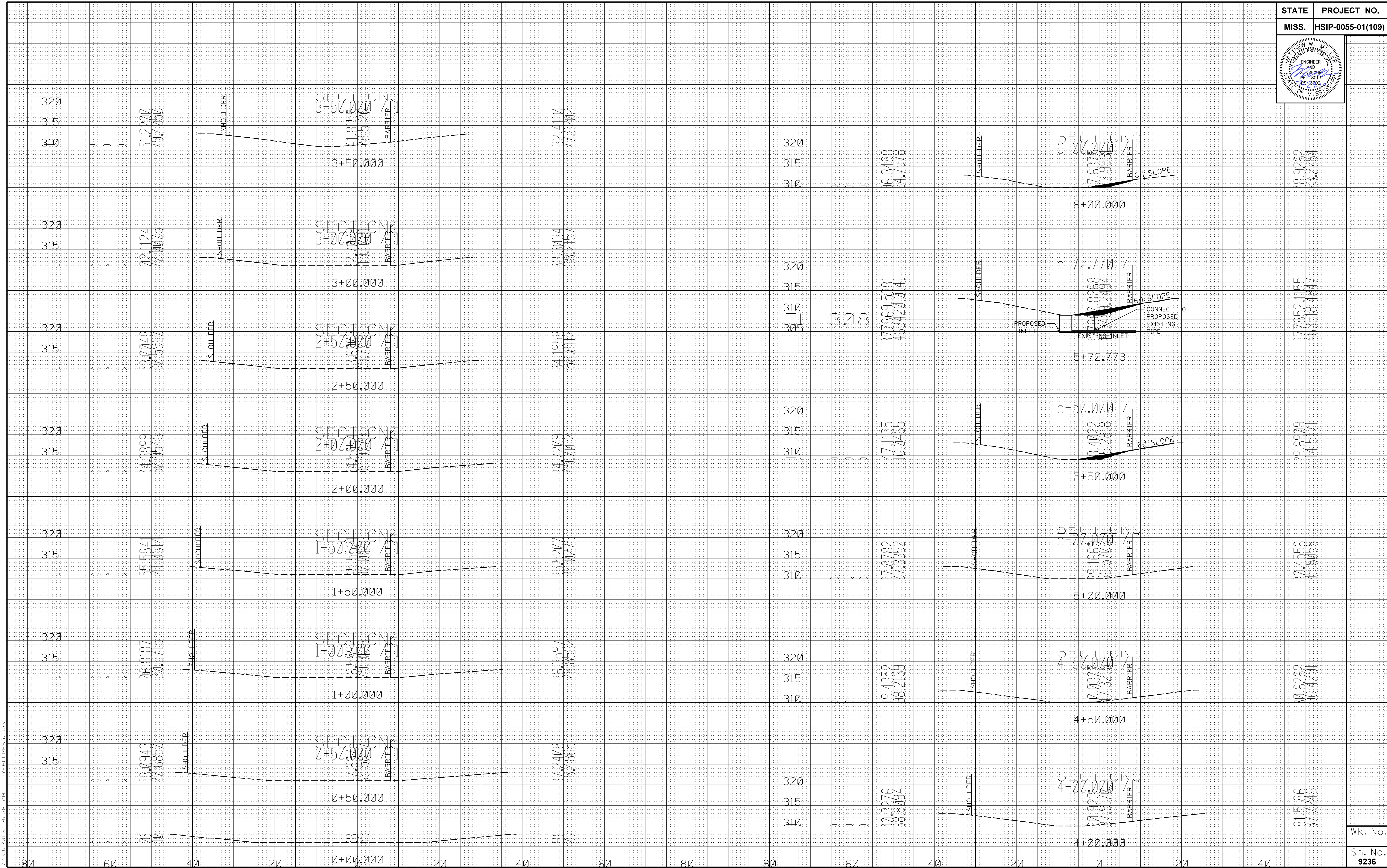
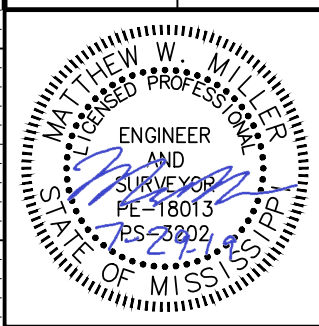

7/30/2019 8:36 AM LAT-HOL.ME55.DGN

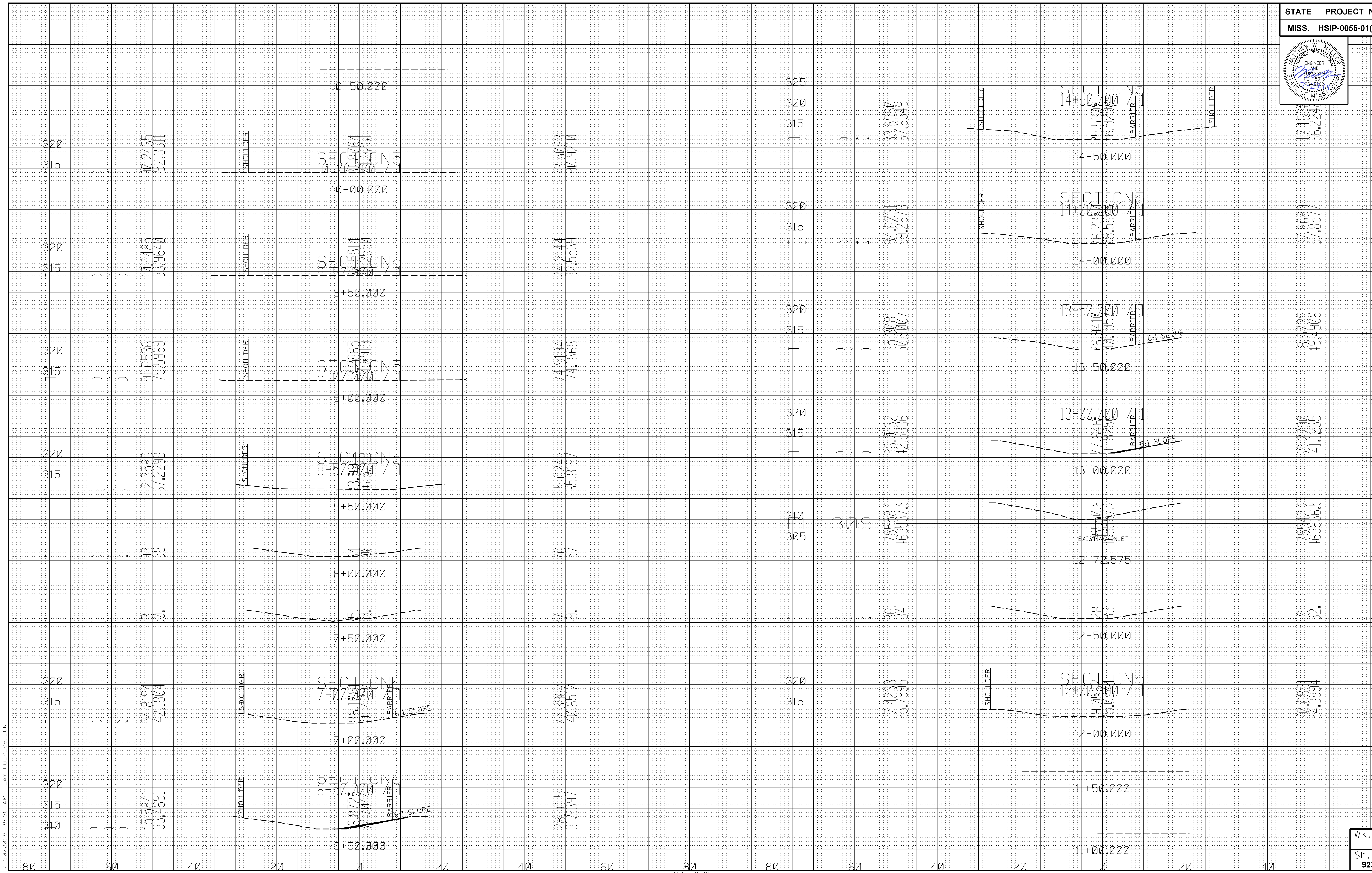
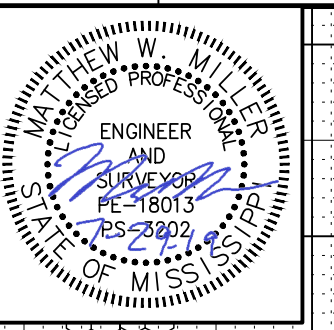

7/30/2019 8:36 AM LAT-HOL.MESS.DGN

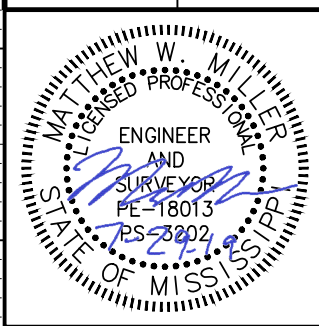

7/30/2019 8:36 AM LAT-HOL.MESS.DGN

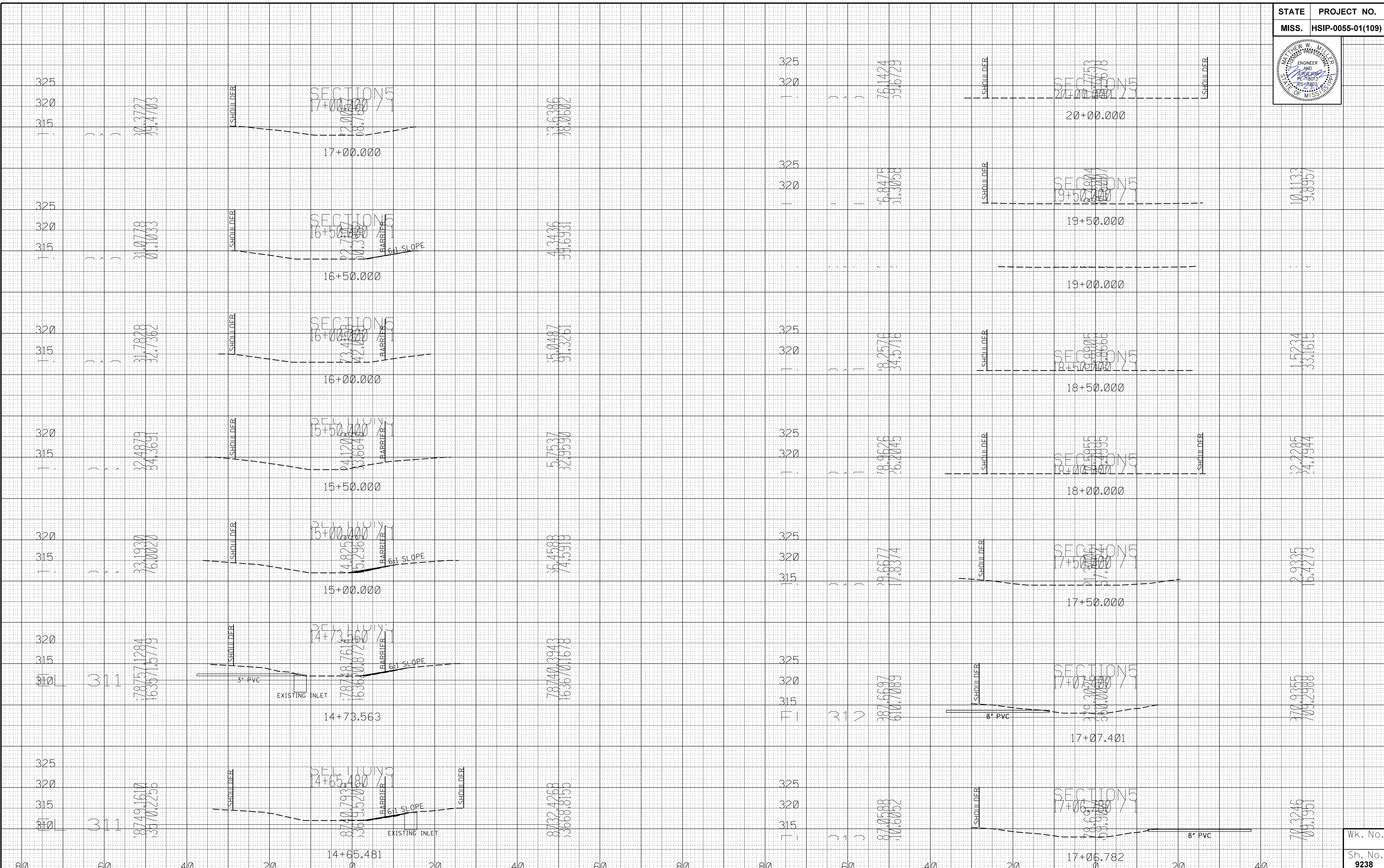

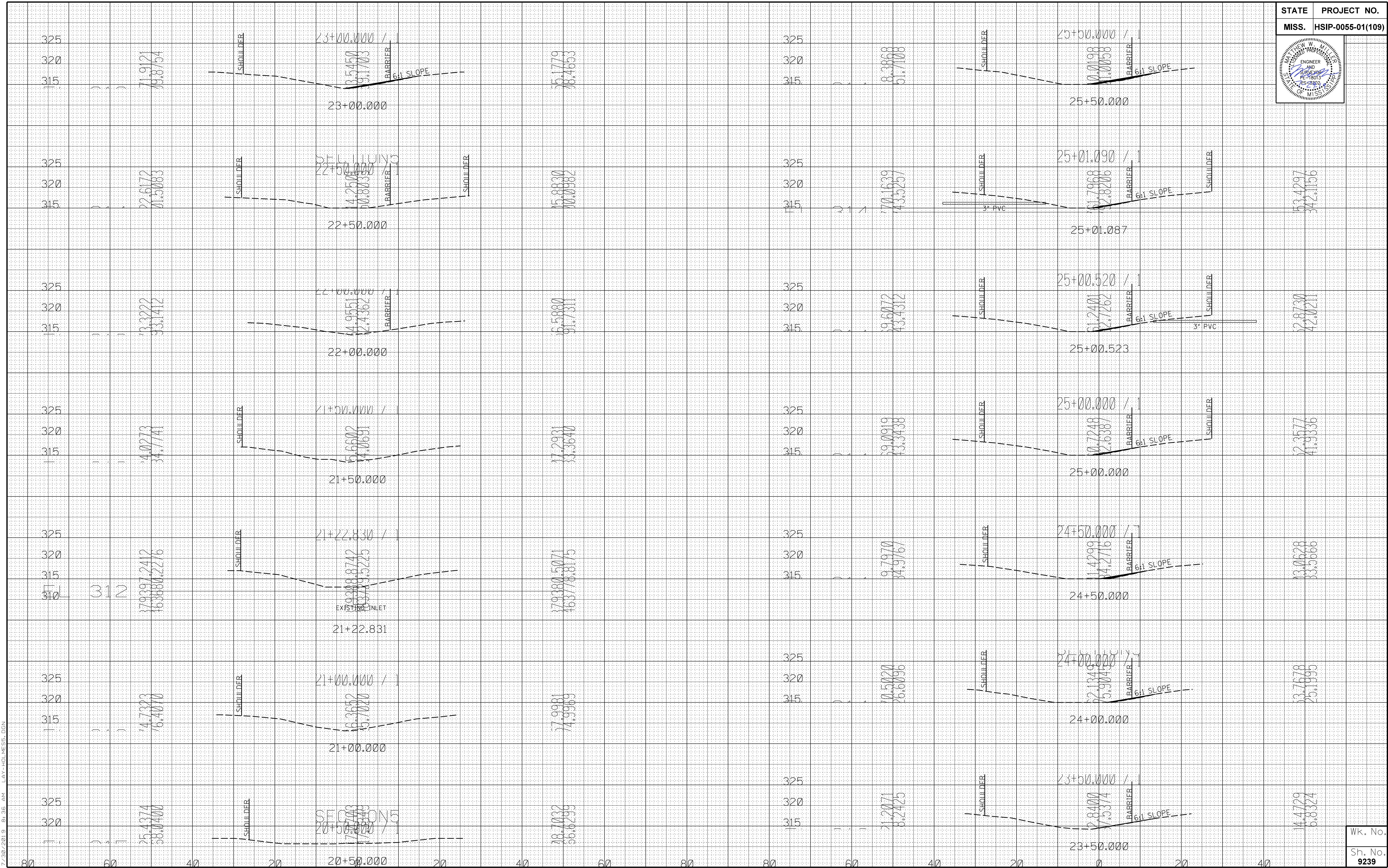
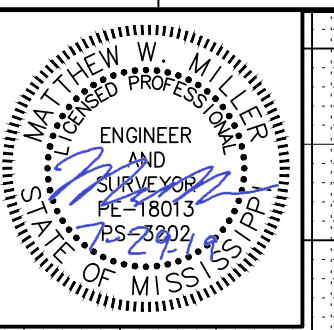

7/30/2019 8:36 AM LAT-HOLMES.DGN

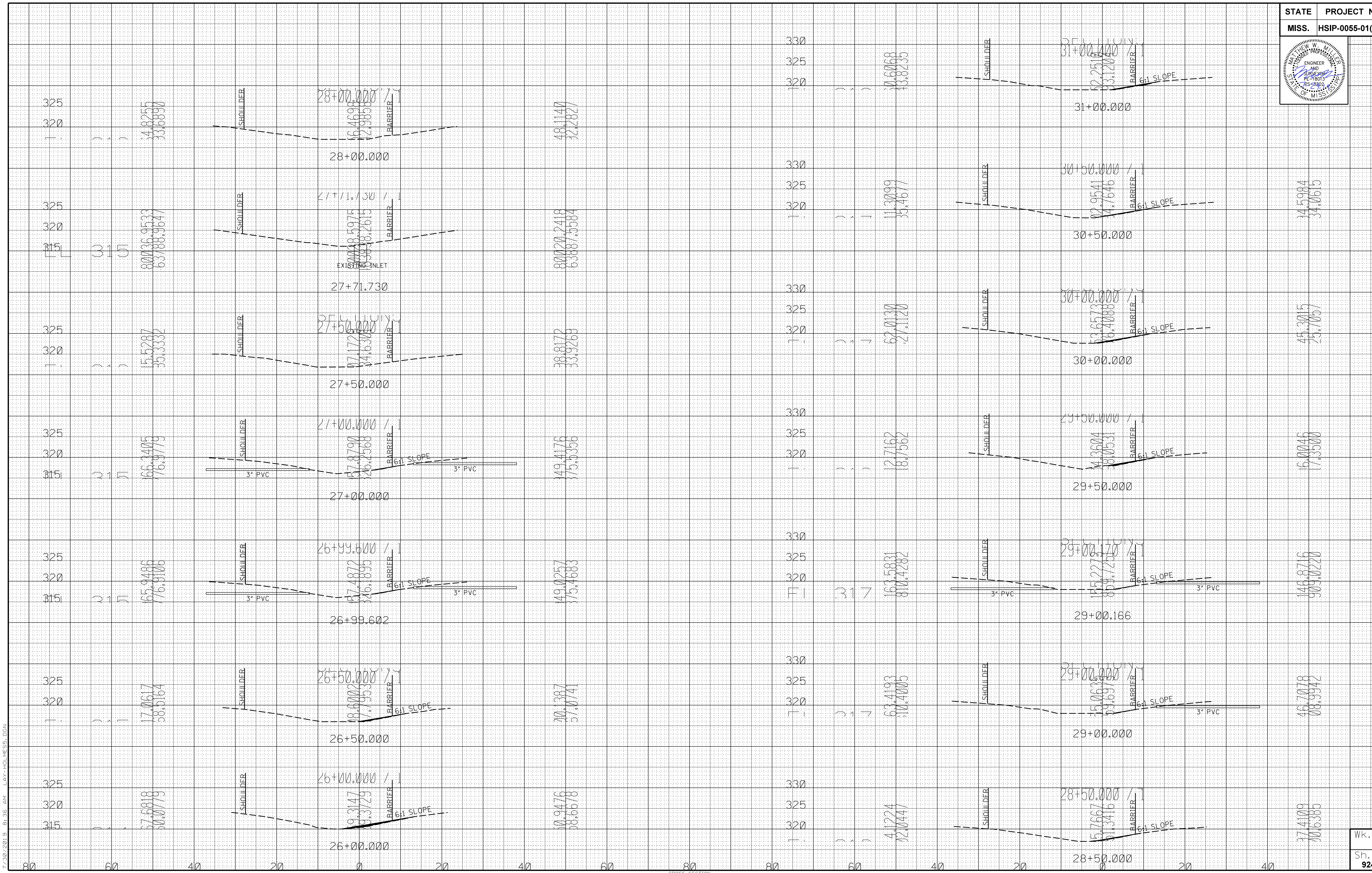

7/30/2019 8:36 AM LAT-HOL.MESS.DGN

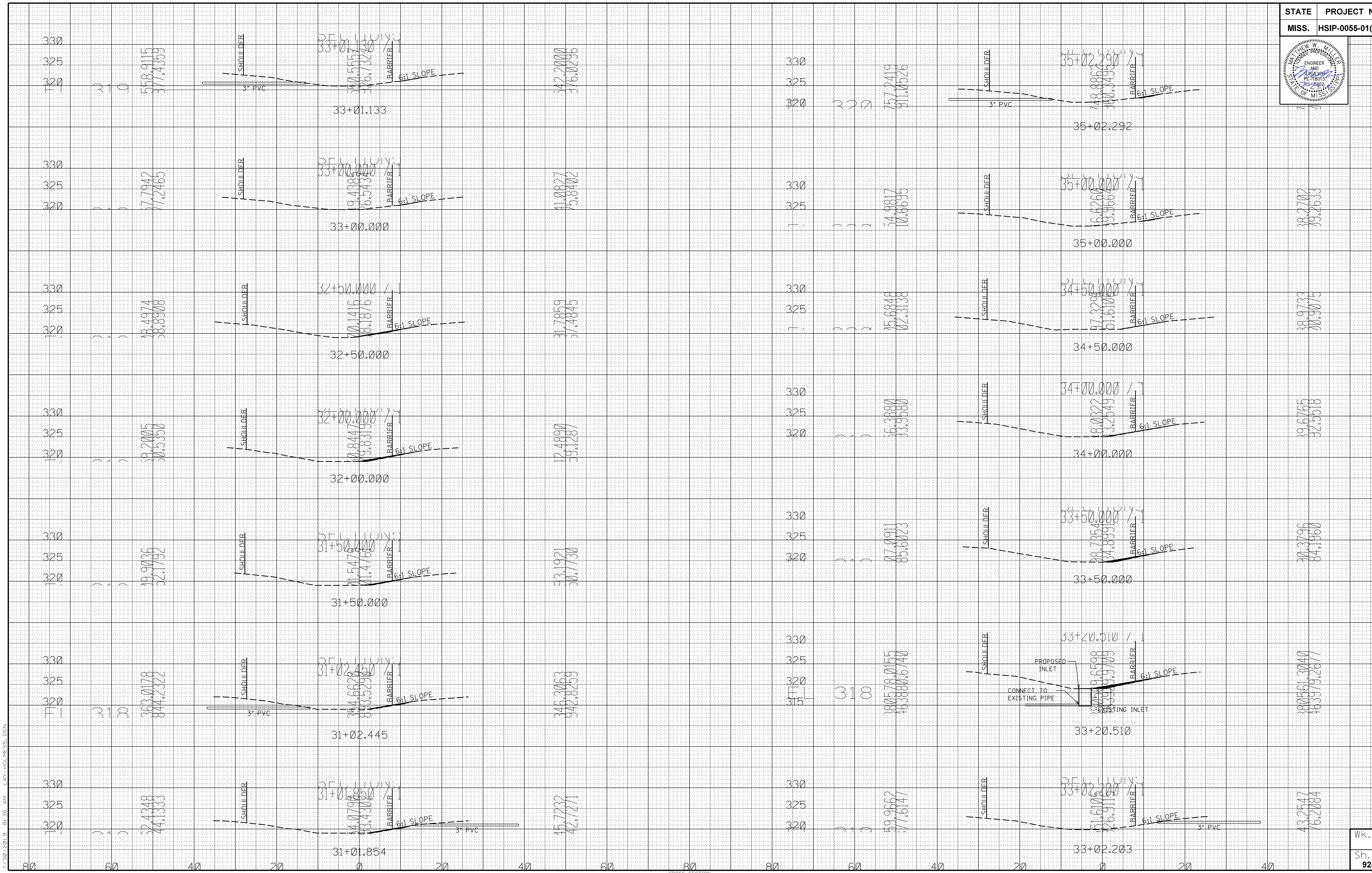
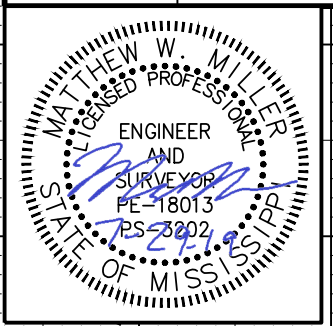

7/26/2019 8:36 AM LAT-HOL.MESS.DGN

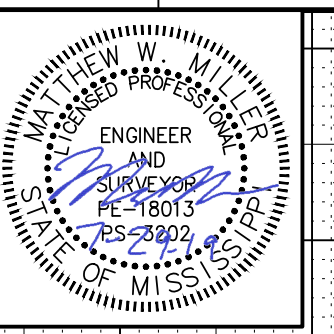

7/30/2019 8:36 AM LAT-HOLMES.DGN

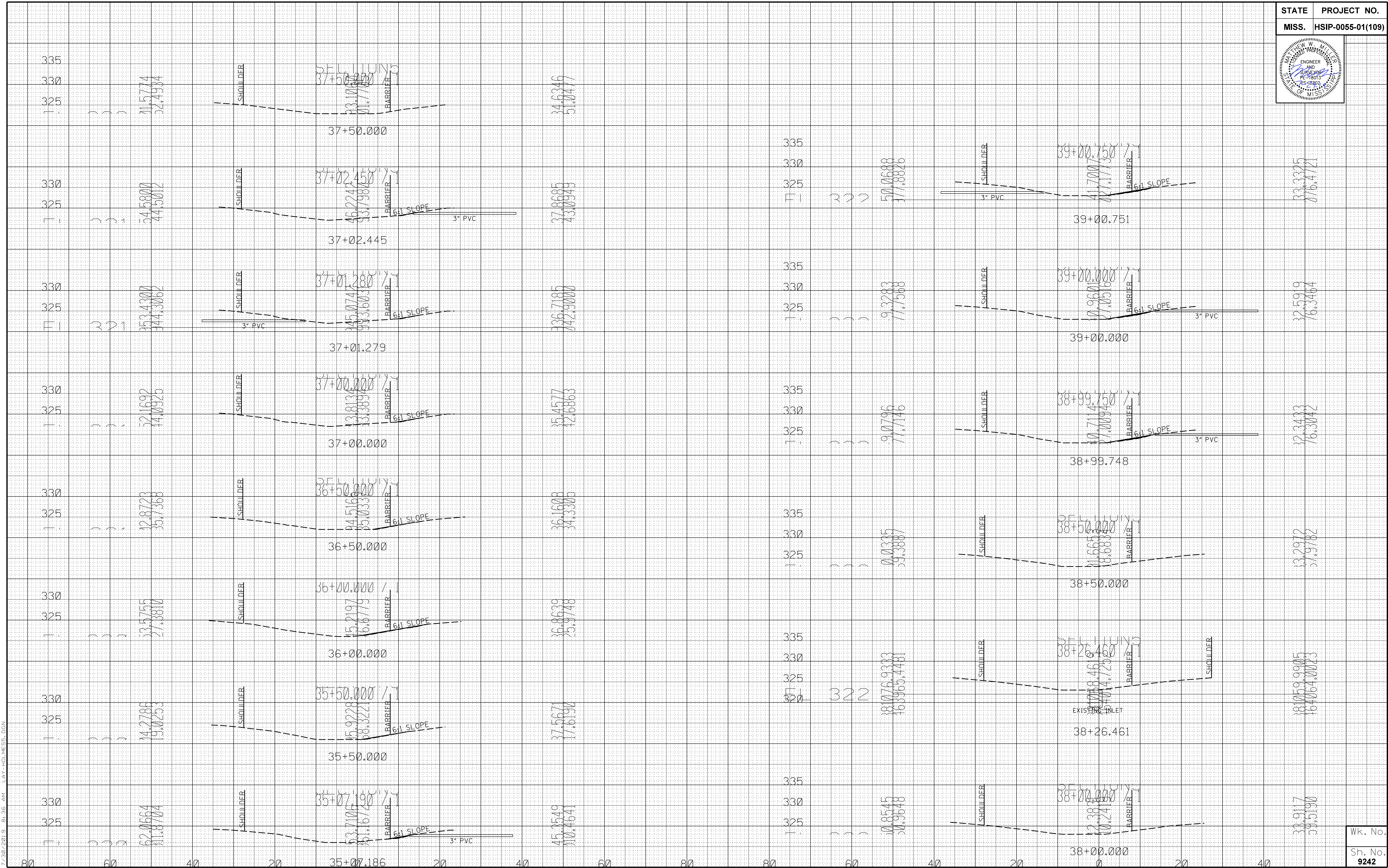

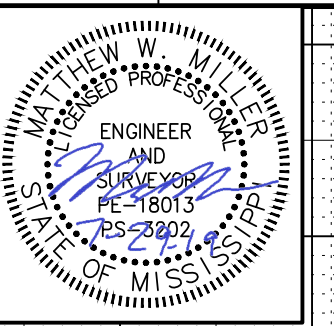

7/30/2019 8:36 AM LAT-HOLMESS.DGN

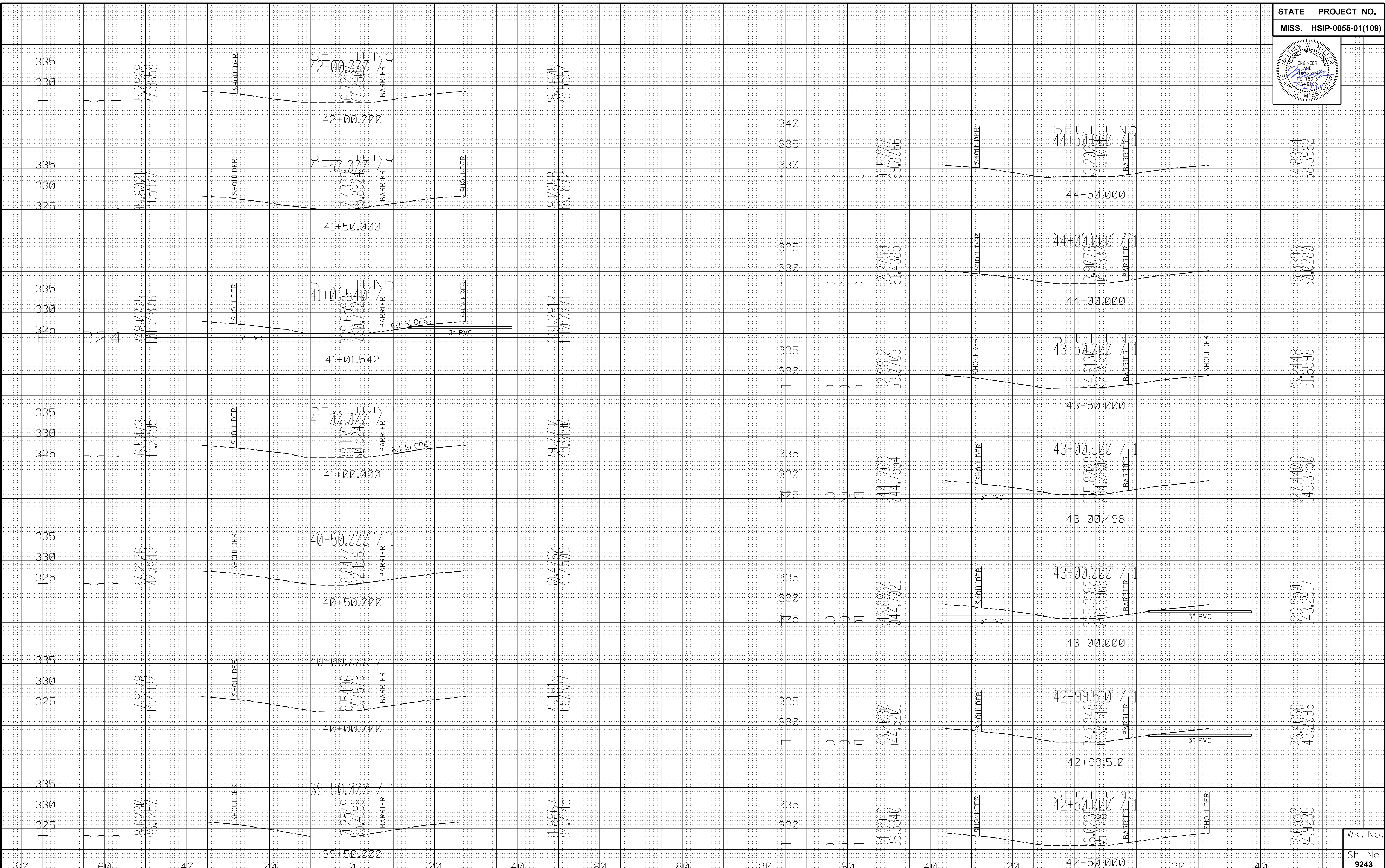

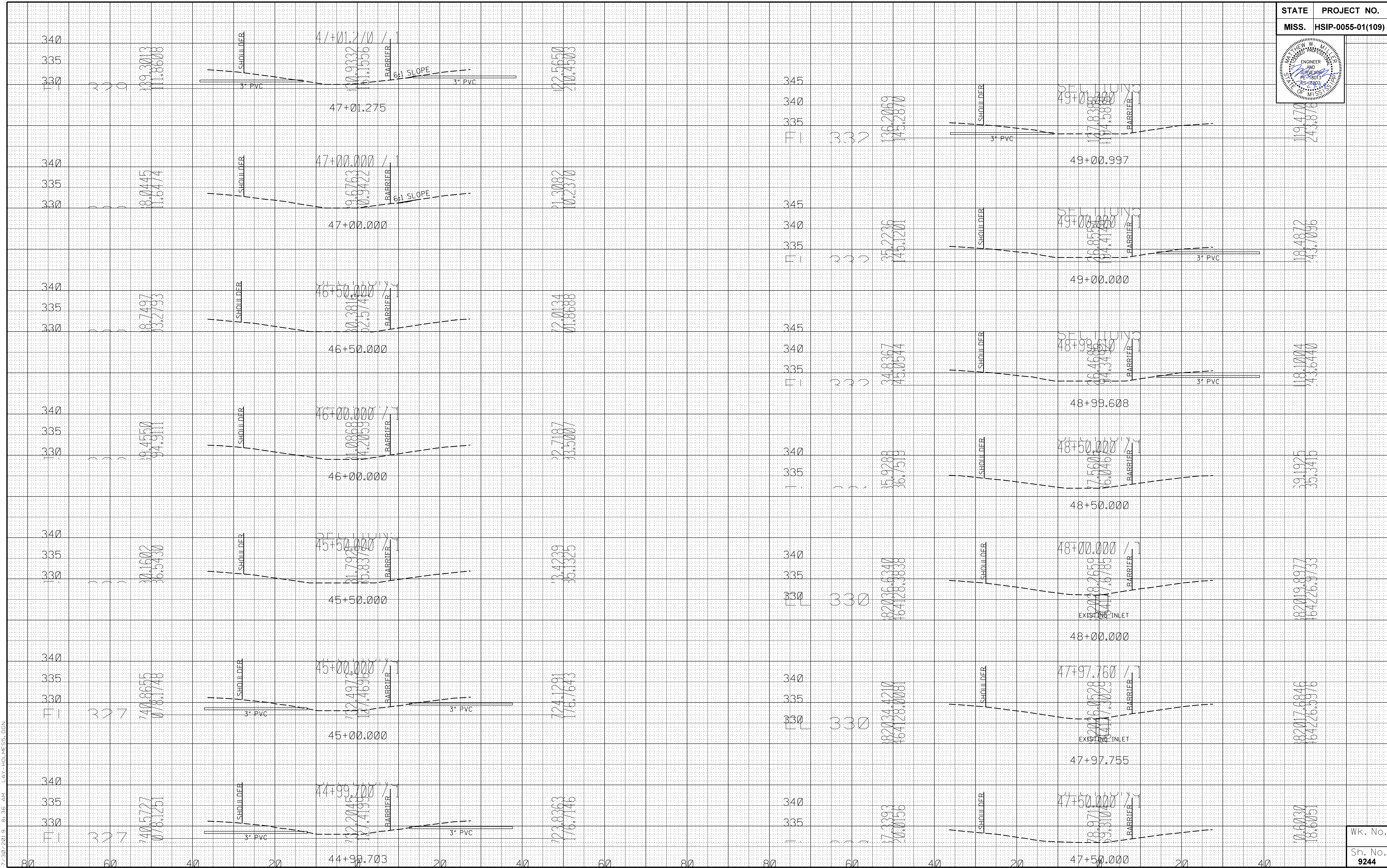
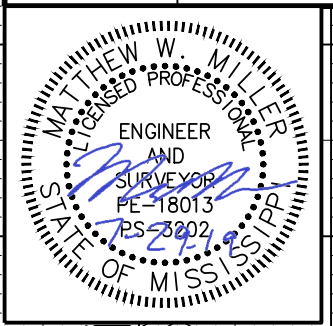

7/26/2019 8:36 AM LAT-HOL.MESS.DGN

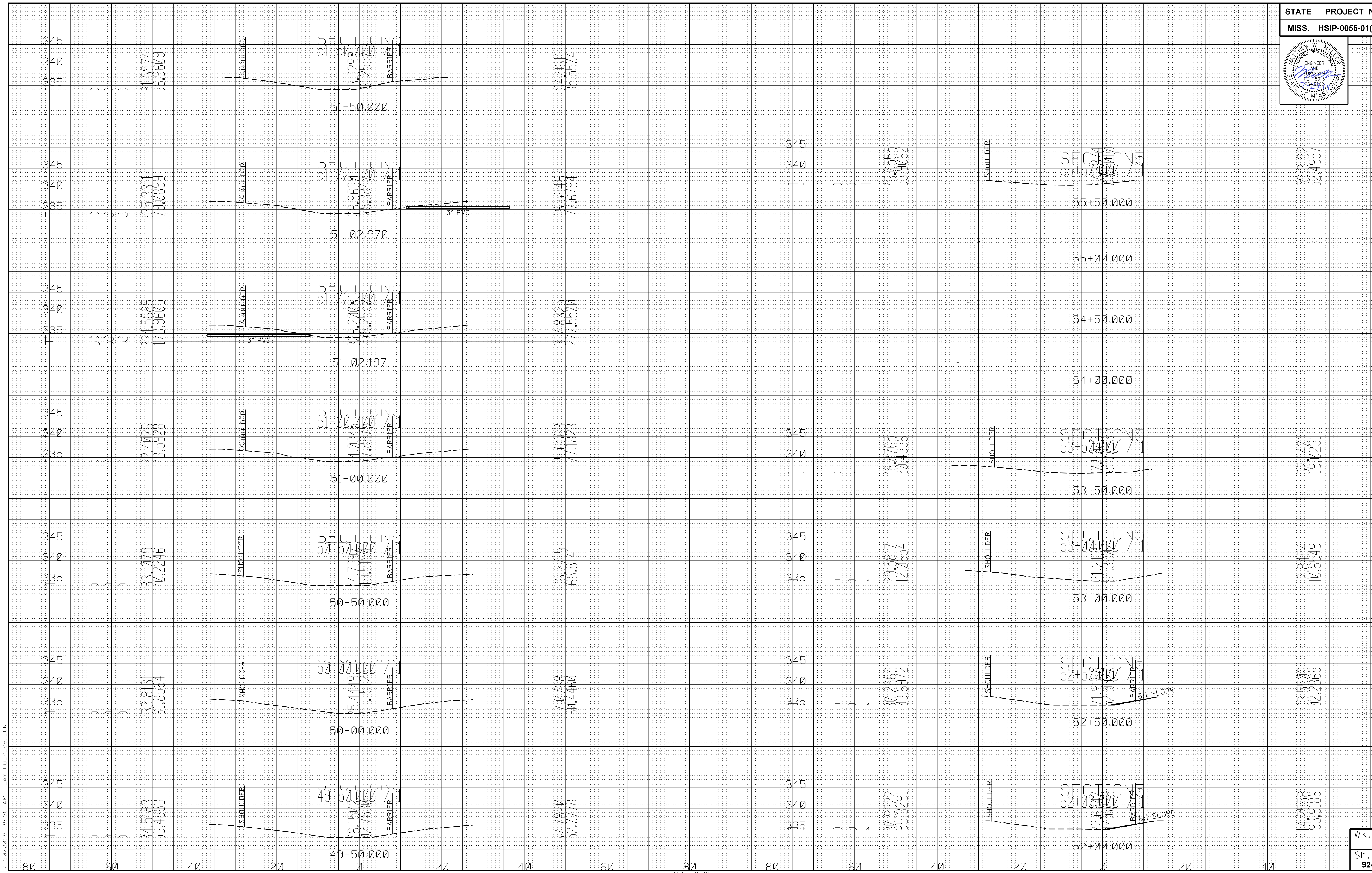
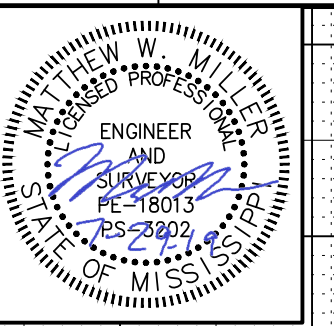

7/26/2019 8:36 AM LAT-HOL.MESS.DGN

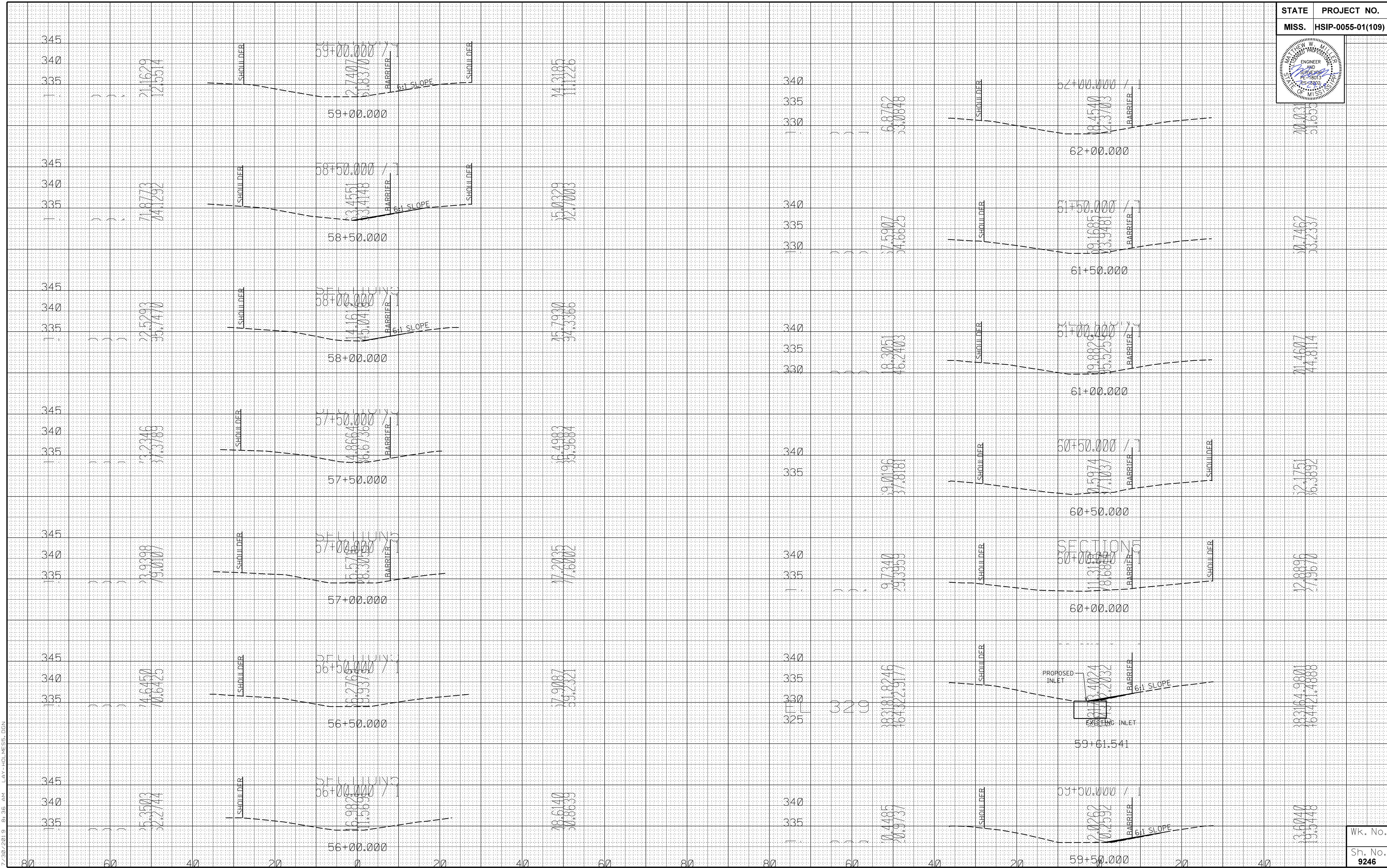
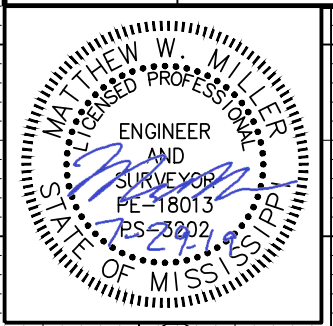

7/30/2019 8:36 AM LAT-HOL.ME55.DGN

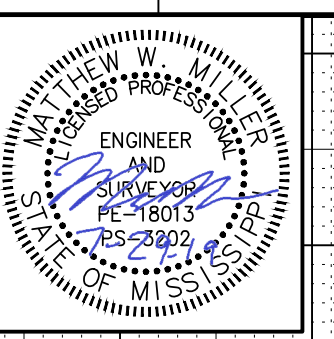

7/30/2019 8:36 AM LAY-HOLMES.DGN

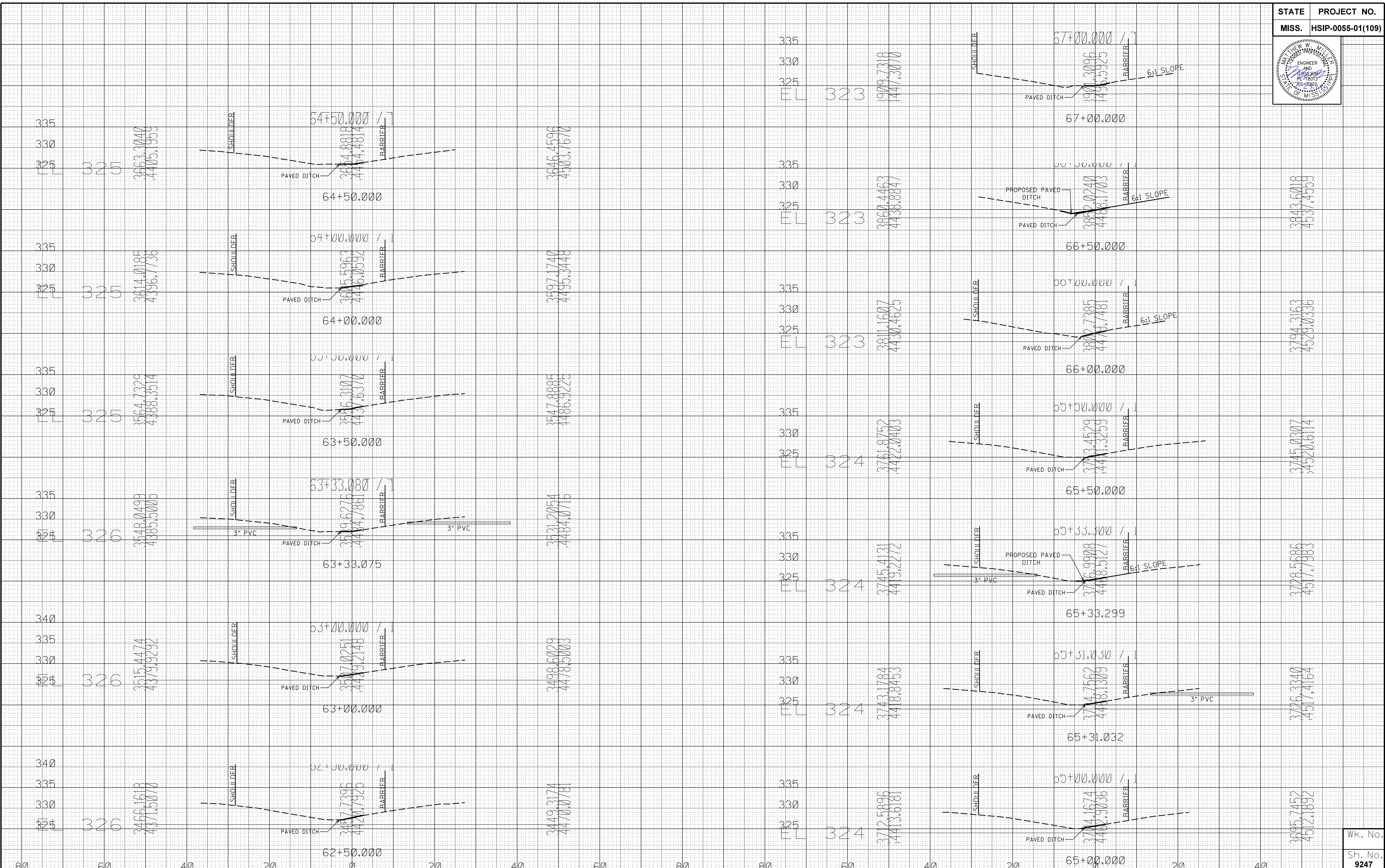

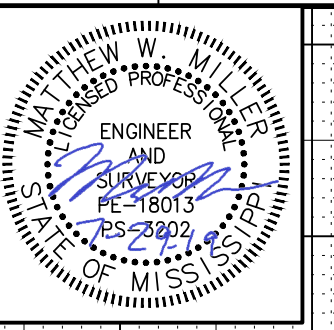

7/26/2019 8:36 AM LAT-HOL.MESS.DGN

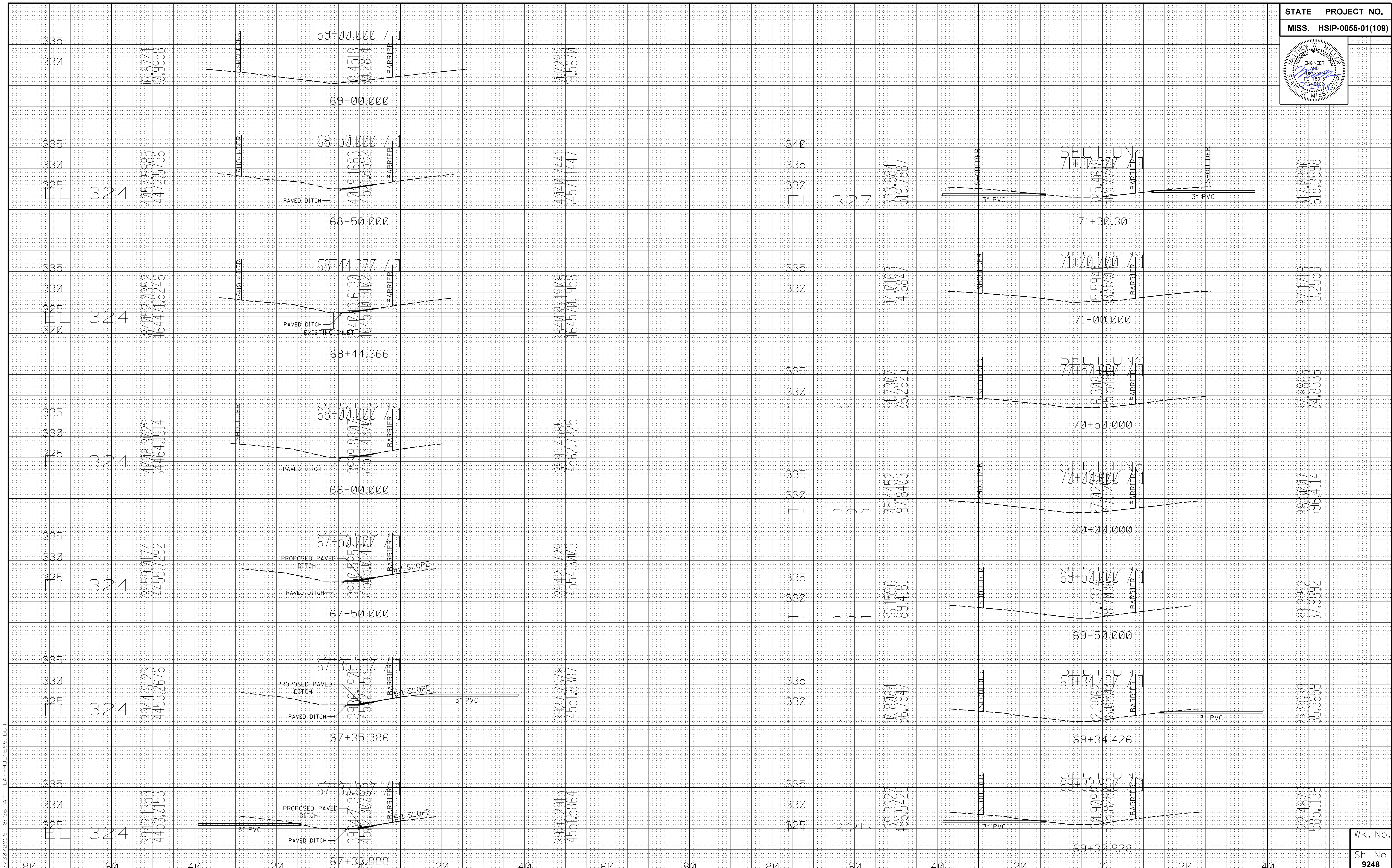

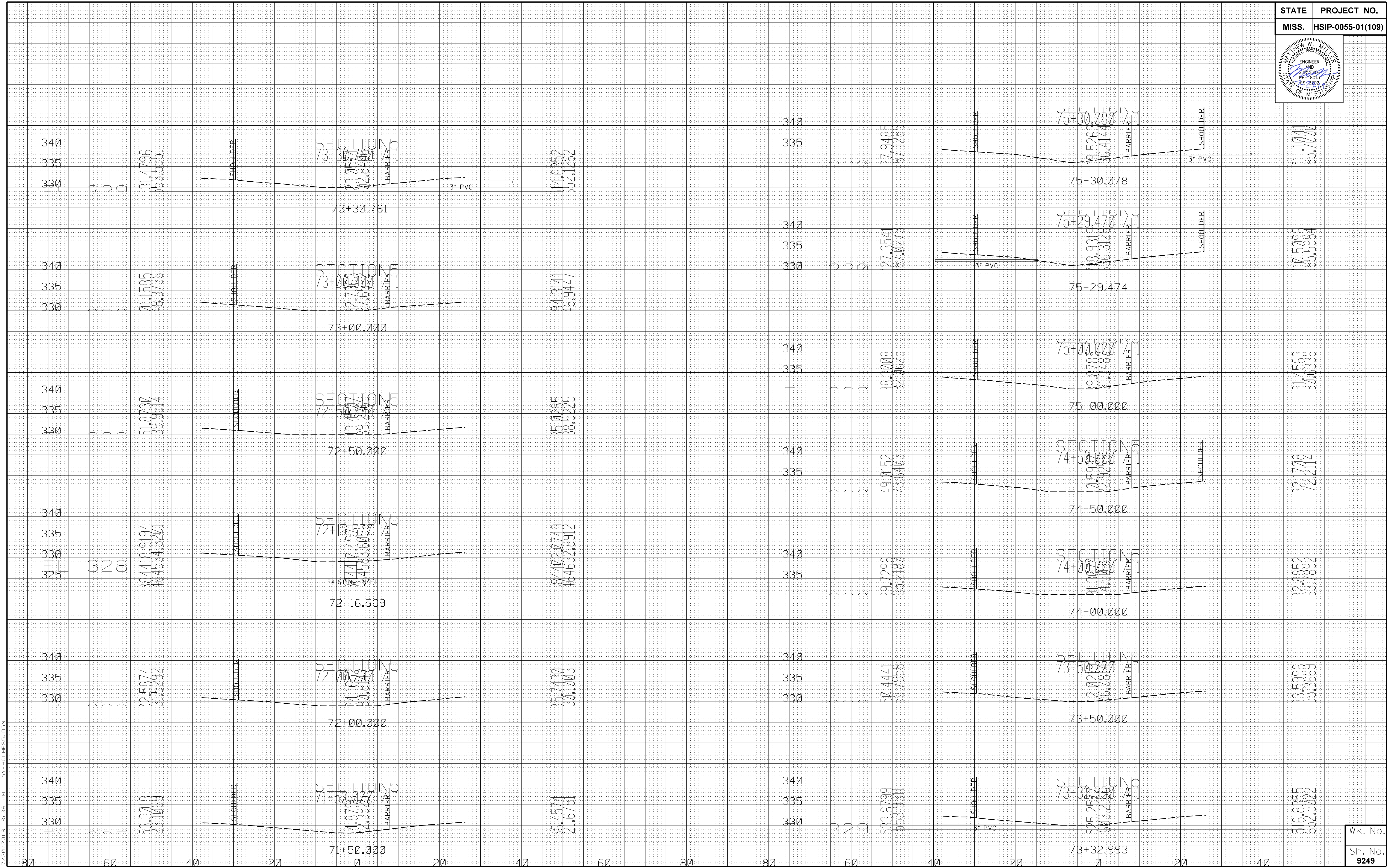
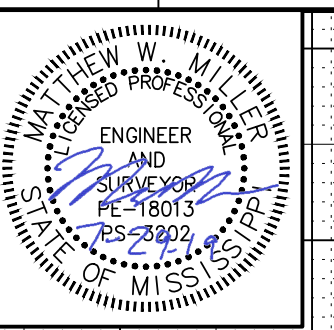

7/30/2019 8:36 AM LAT-HOLMESS.DGN

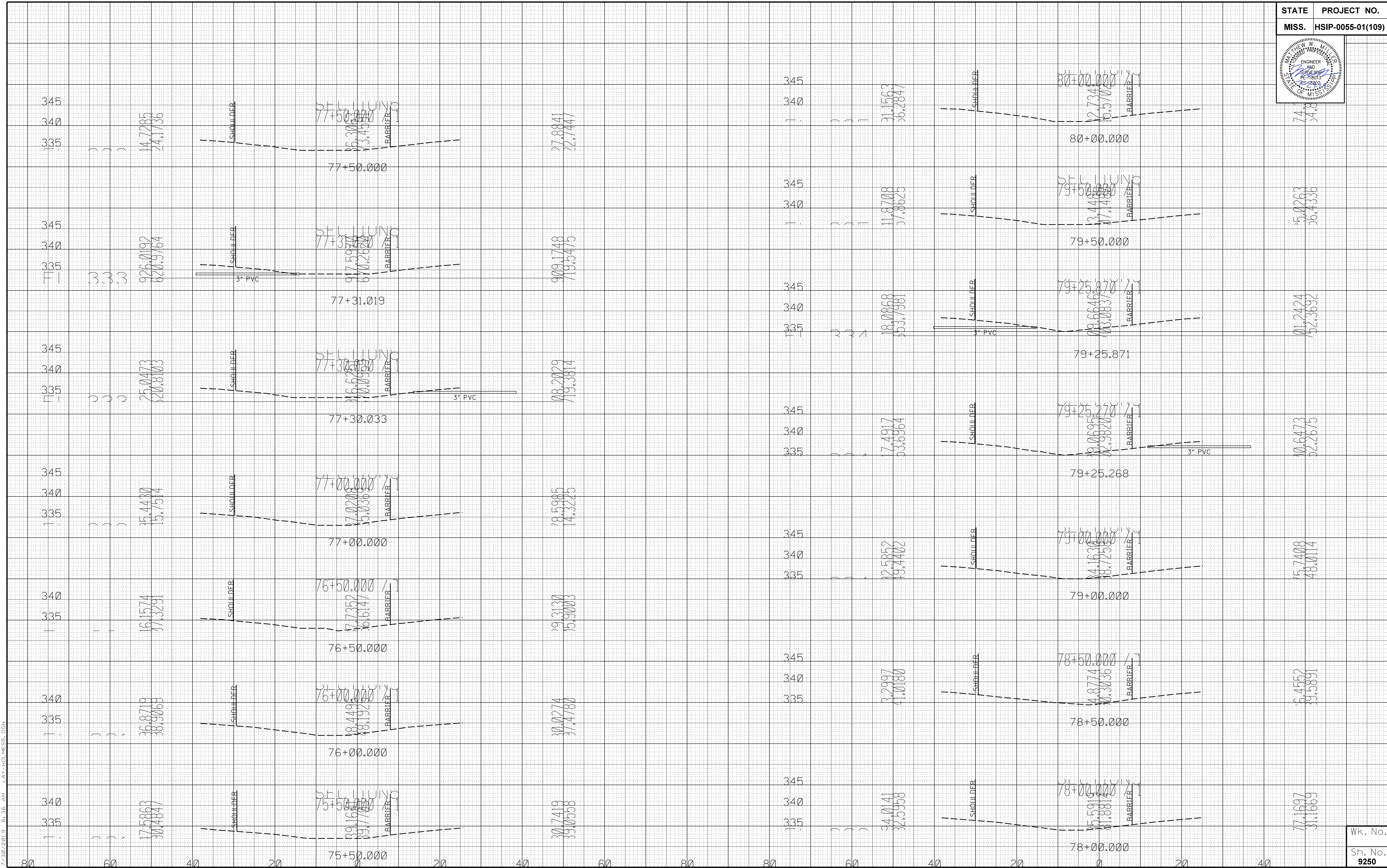
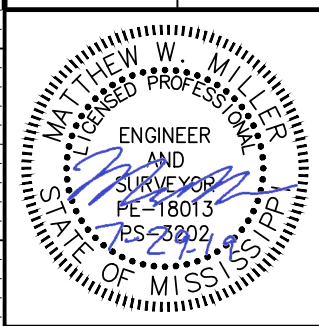

7/30/2019 8:36 AM LAT-HOLMES.DGN

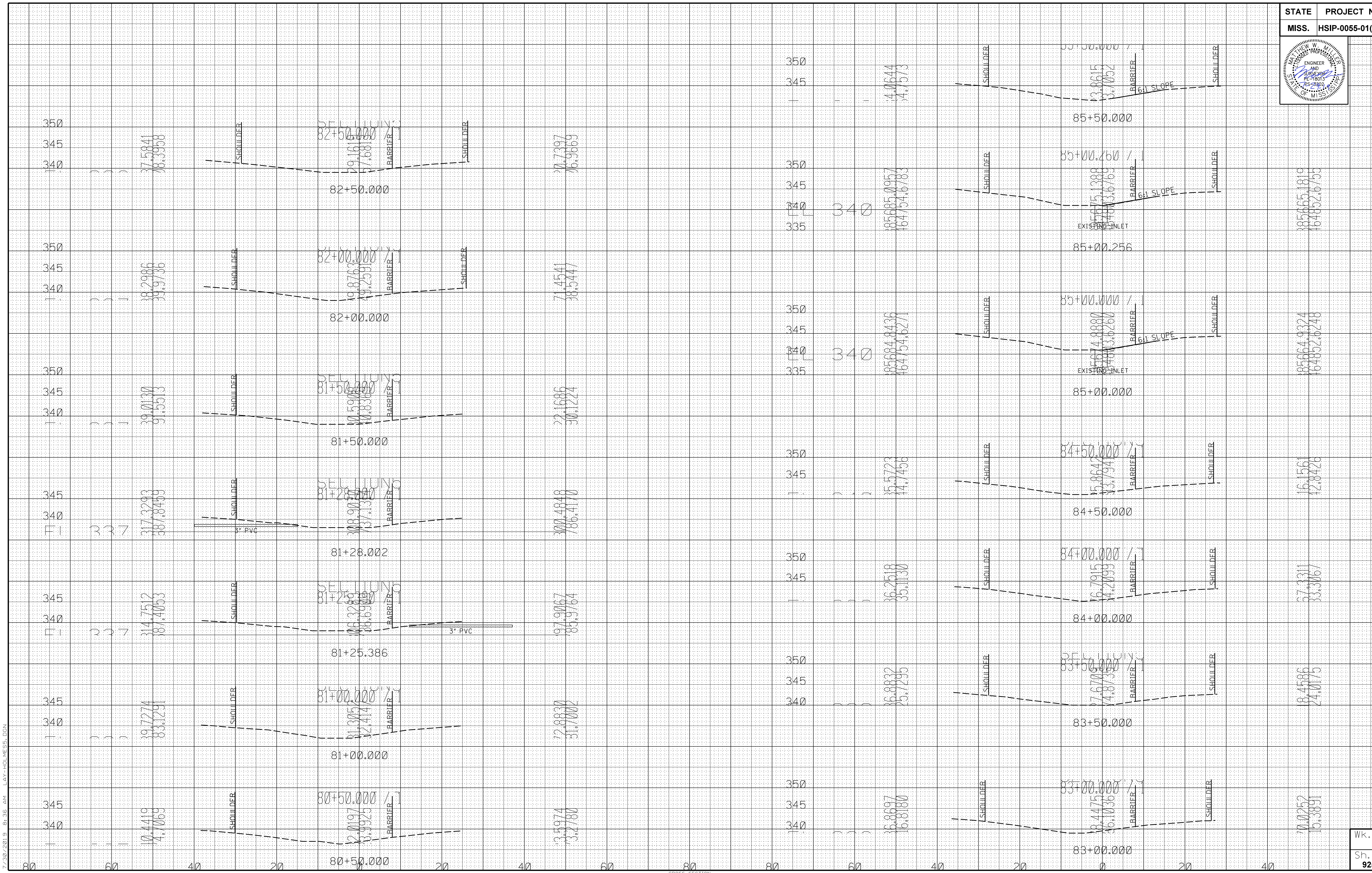

7/26/2019 8:36 AM LAT-HOLMES.DGN

7/30/2019 8:36 AM LAT-HOL.MESS.DGN

STATE	PROJECT NO.
MISS.	HSIP-0055-01(109)

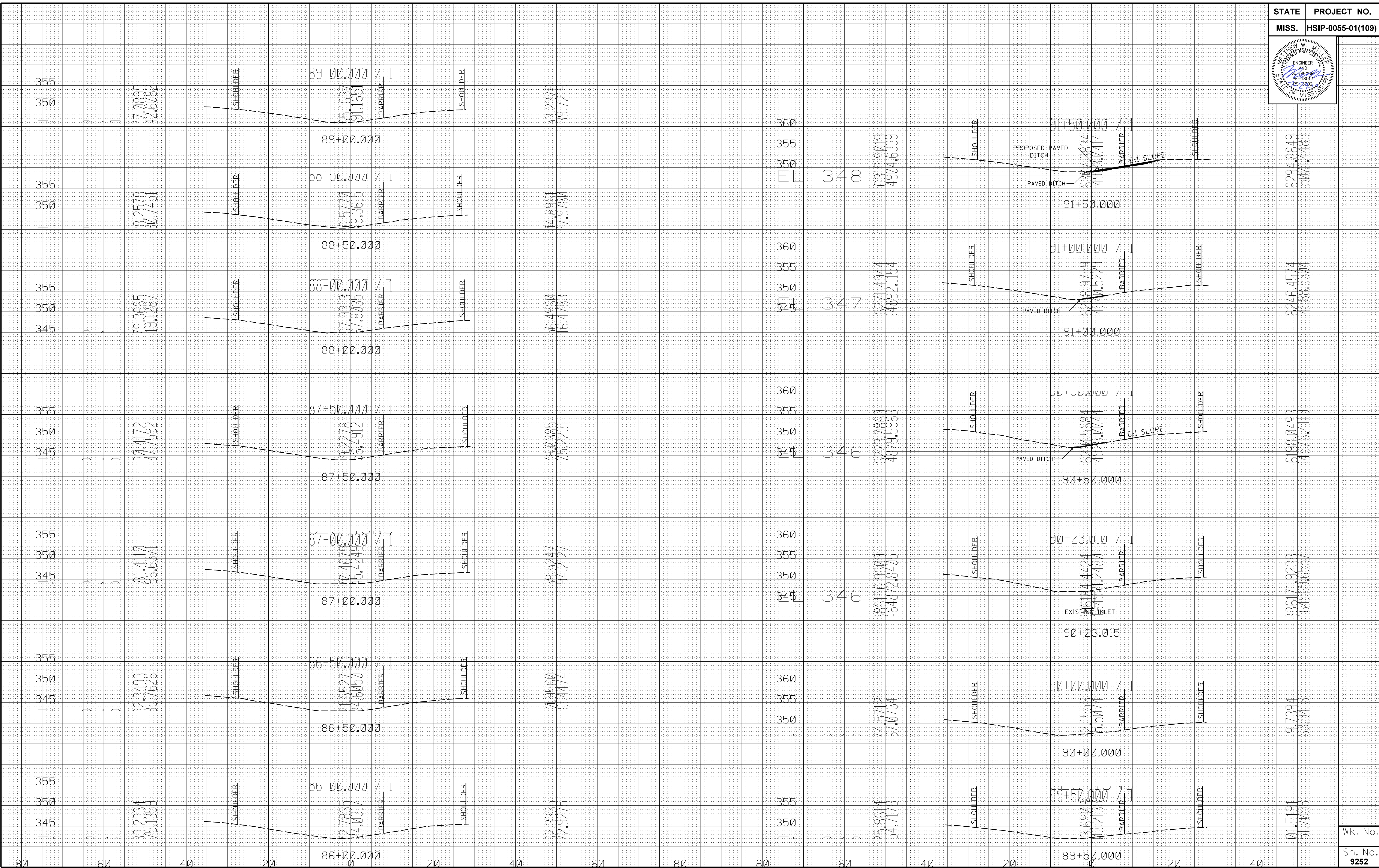

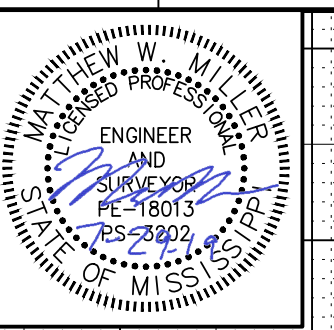

7/30/2019 8:36 AM LAT-HOL.MESS.DGN

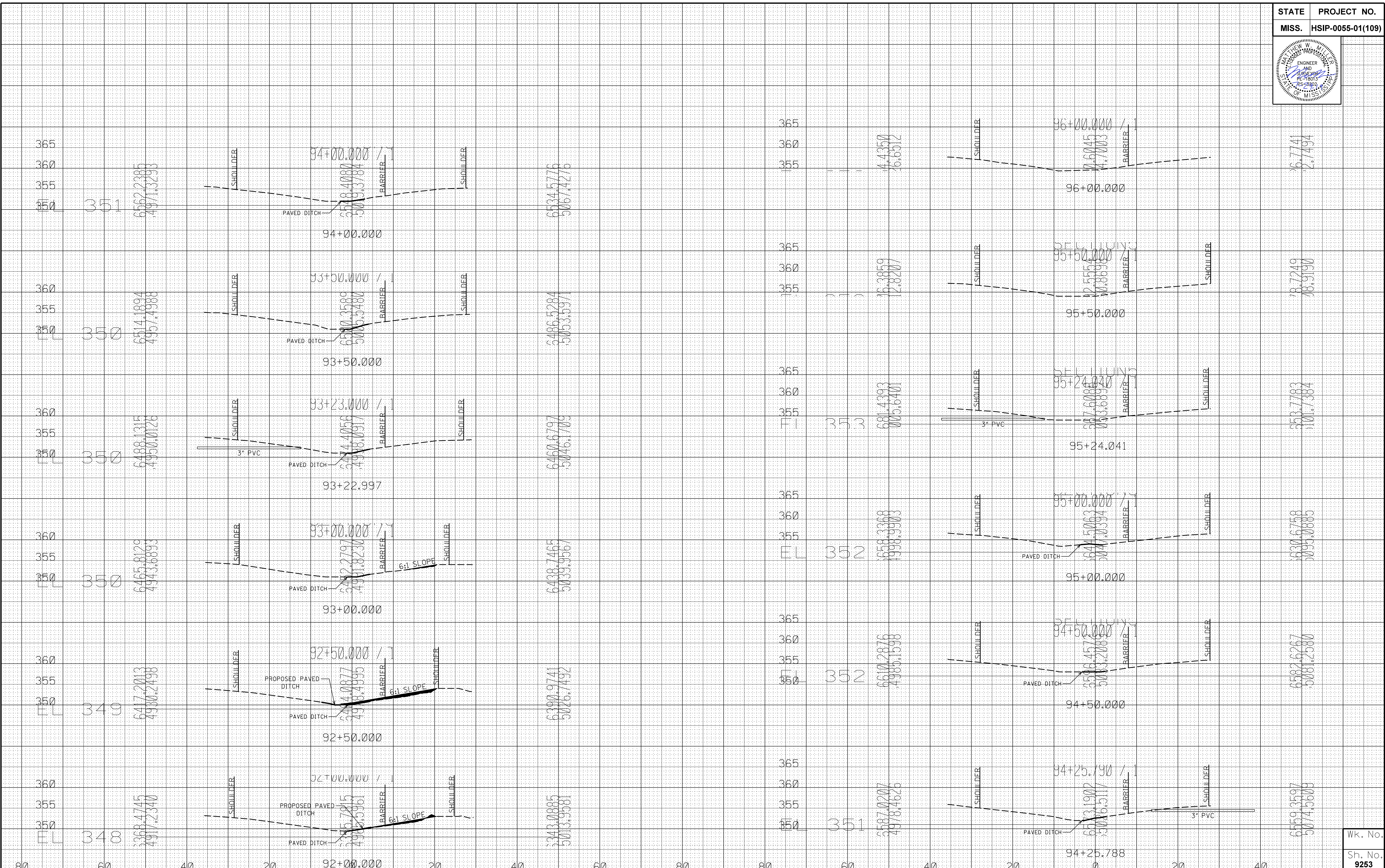

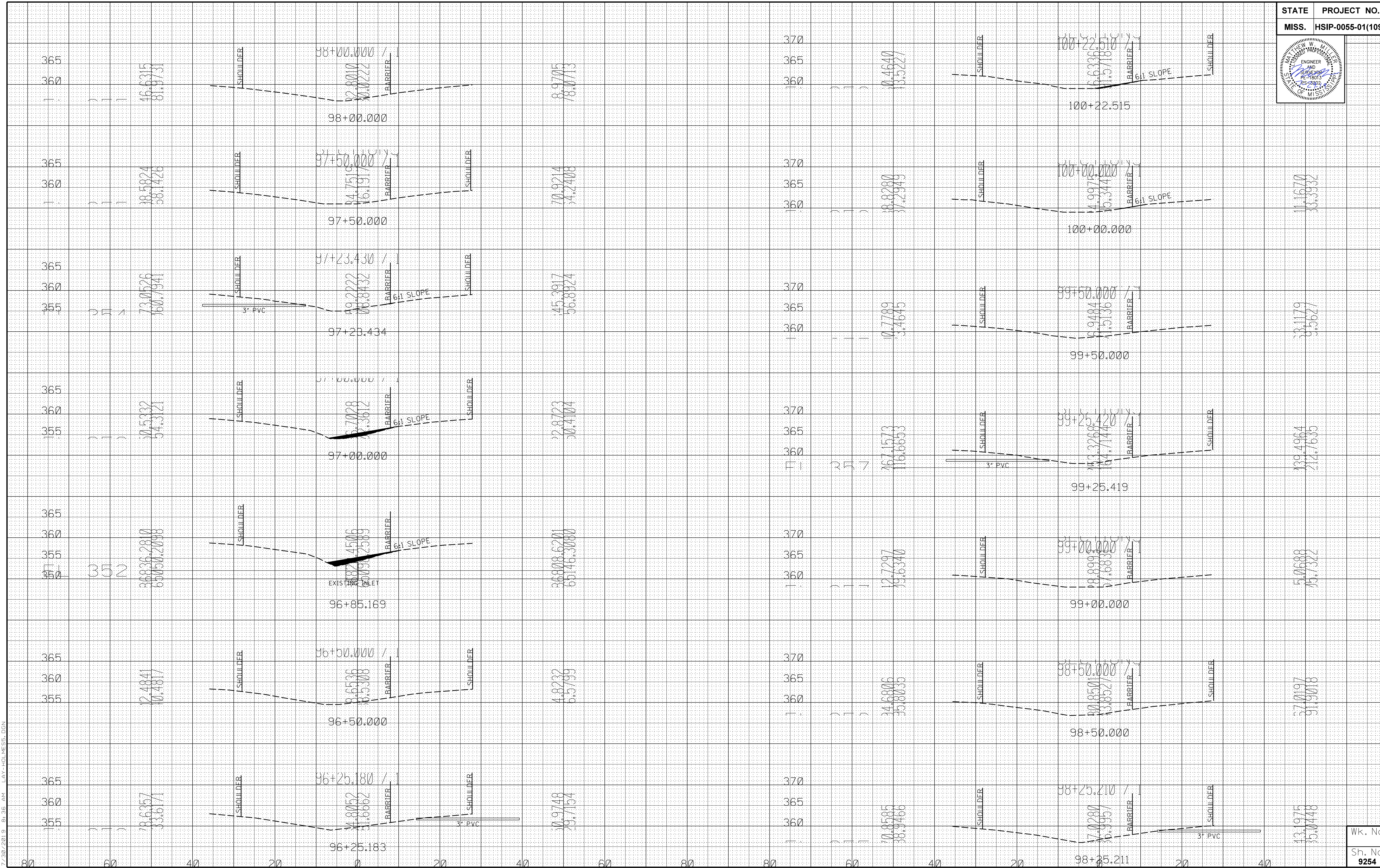
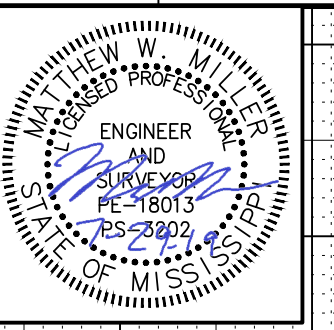

7/30/2019 8:36 AM LAY-HOLMESS.DGN

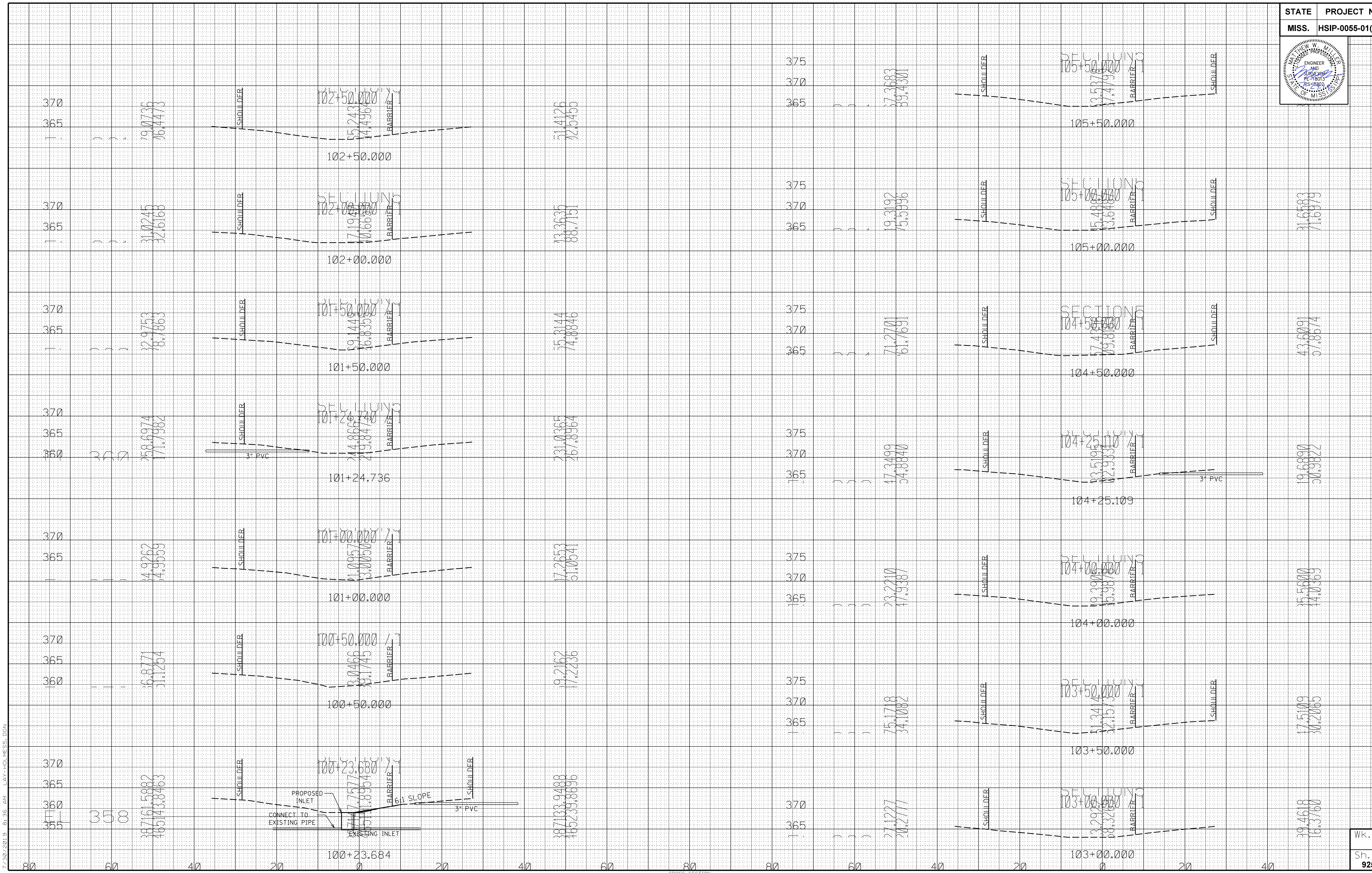
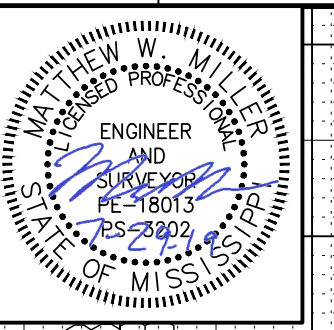

7/30/2019 8:36 AM LAY-HOLMES.DGN

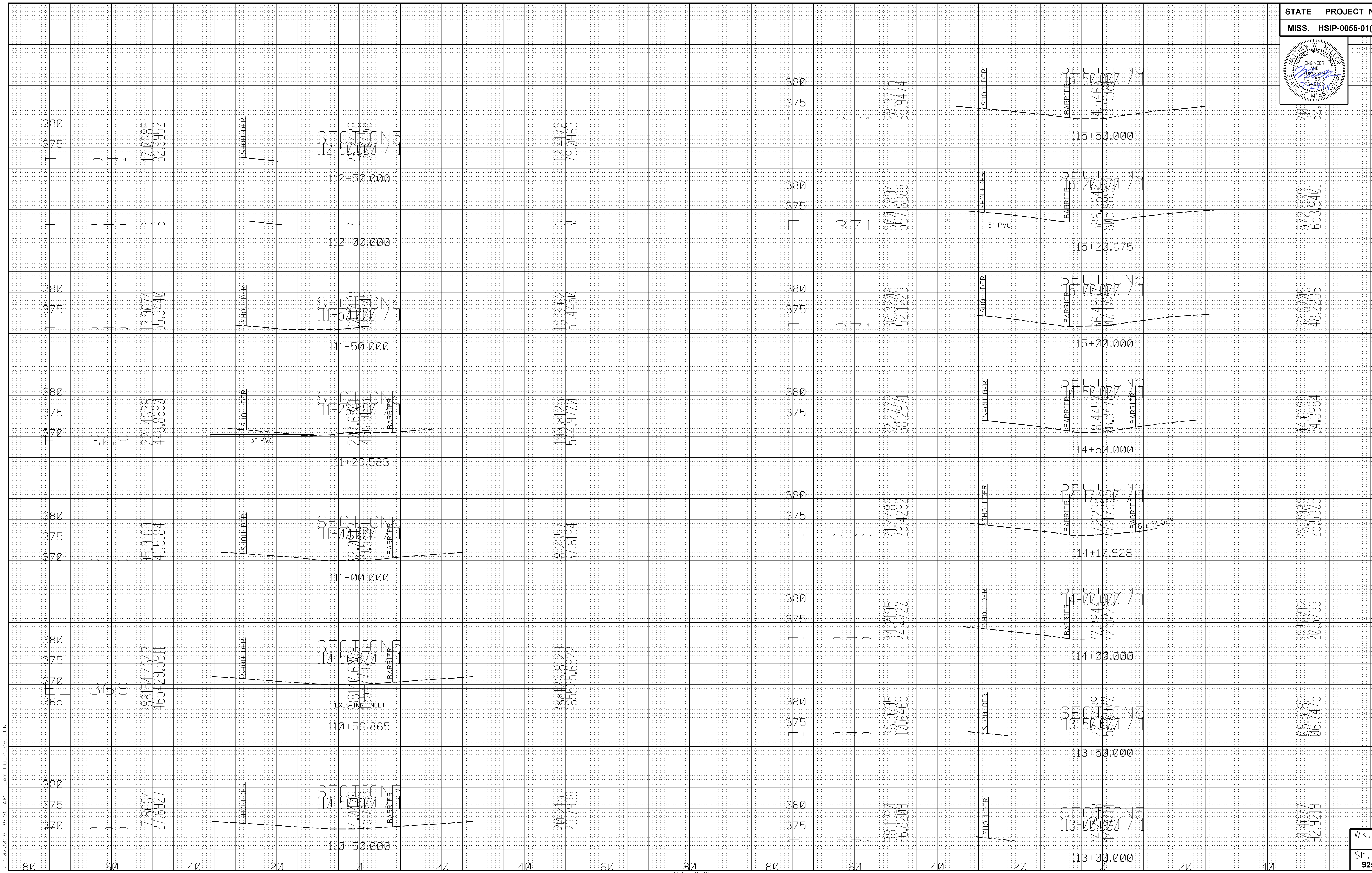
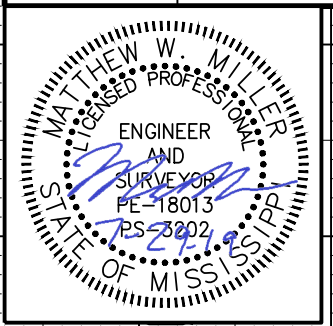

7/26/2019 8:36 AM LAT-HOL.MESS.DGN

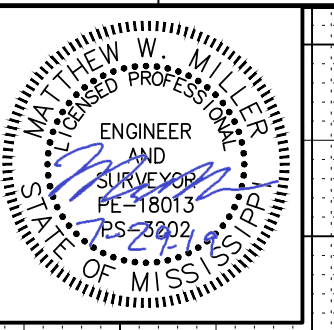

7/26/2019 8:36 AM LAT-HOLMESS.DGN

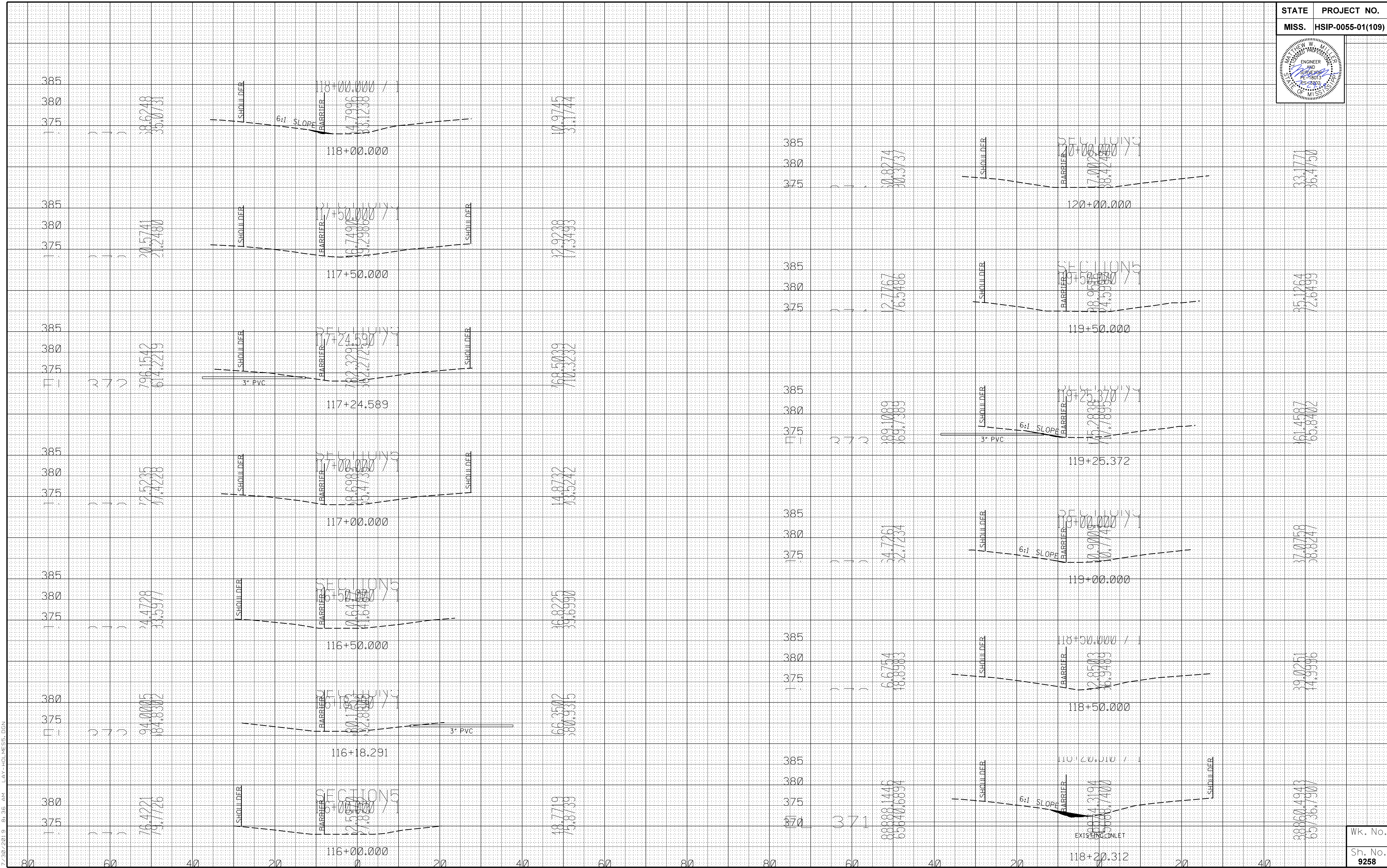

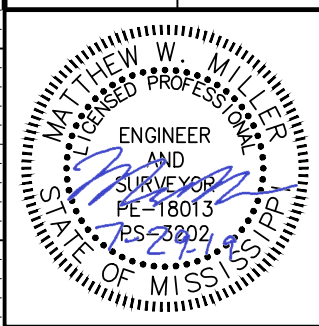

7/26/2019 8:36 AM LAT-HOL.MESS.DGN

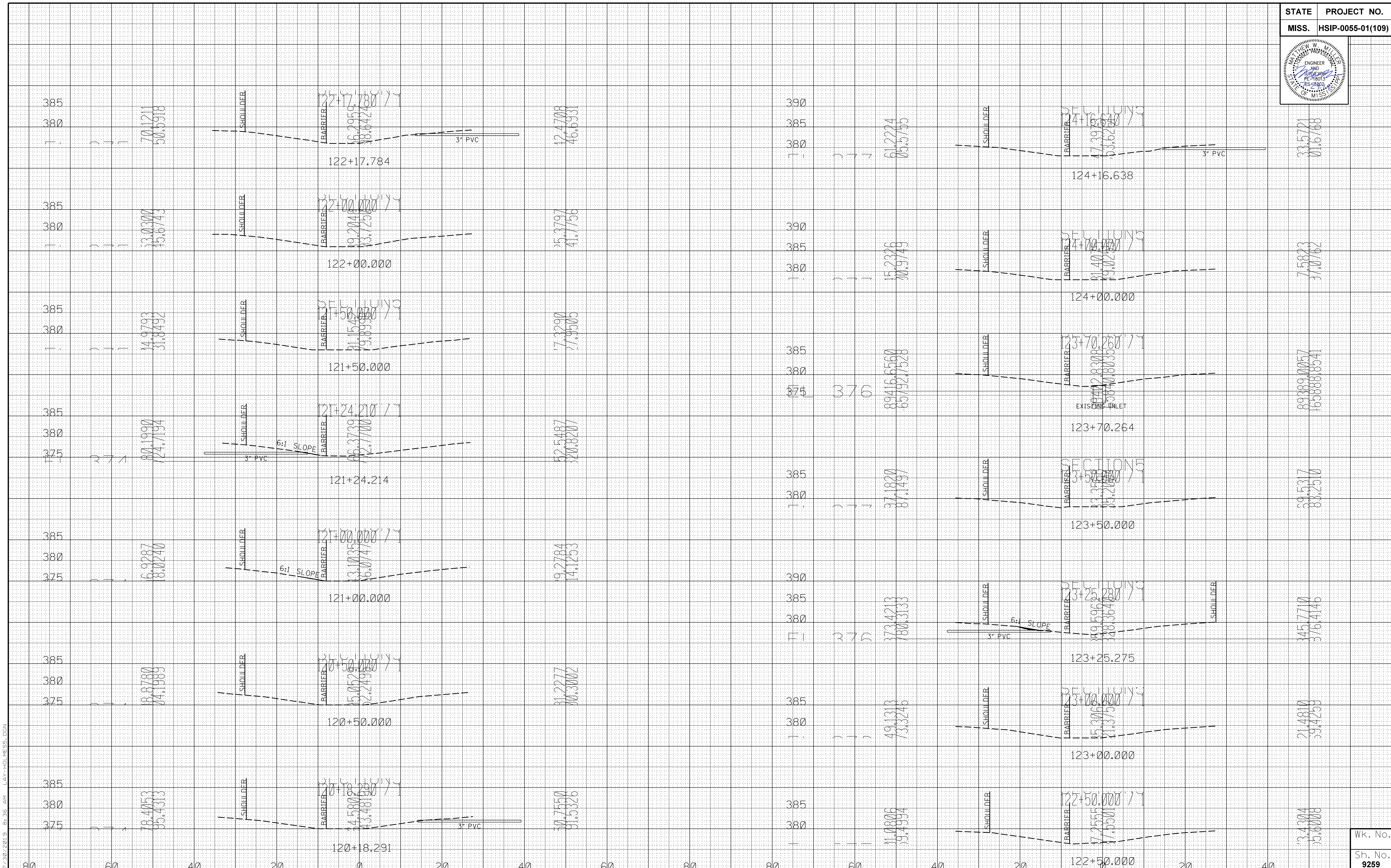

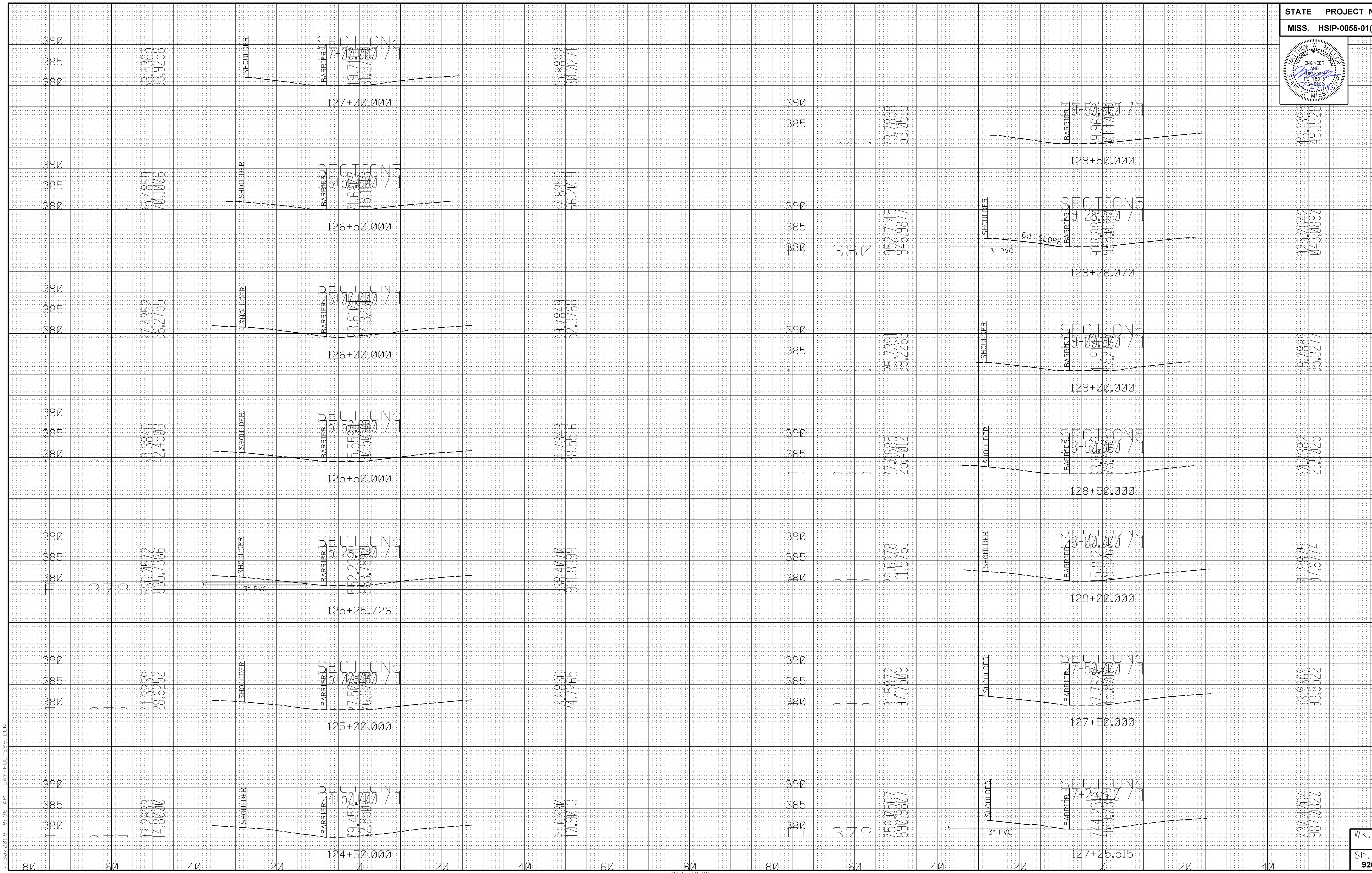
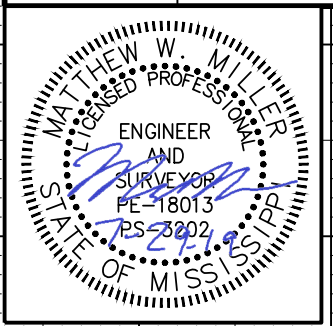

7/30/2019 8:36 AM LAT-HOL.MESS.DGN

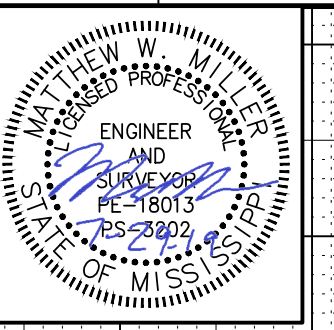

7/30/2019 8:36 AM LAT-HOL.ME55.DGN

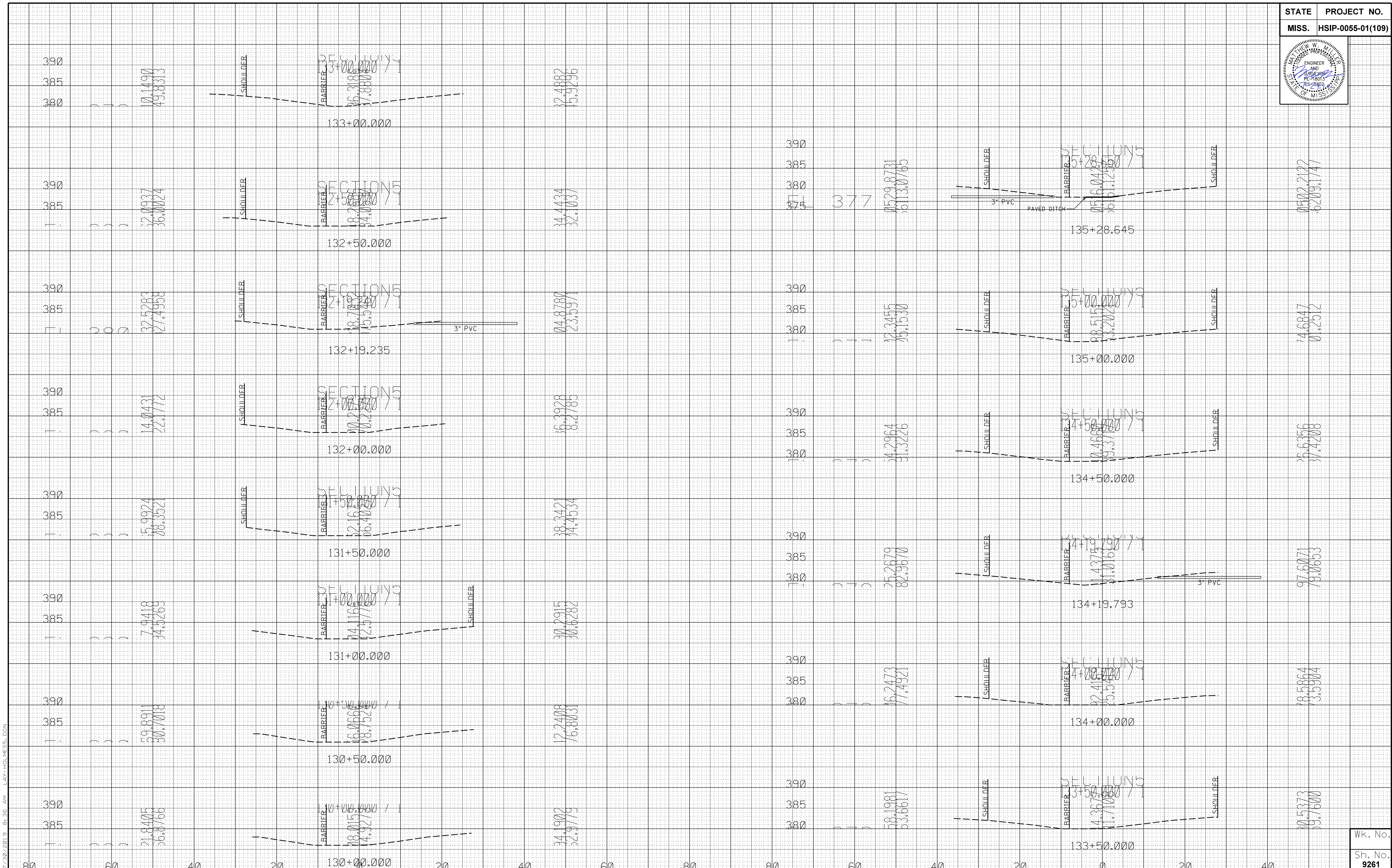

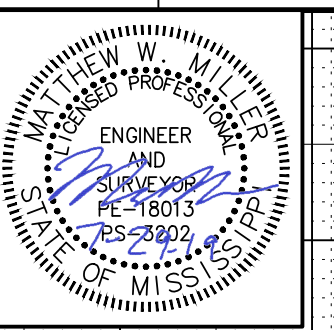

375

388.4334
320.3443

39.0778
11.8946

68.110286
62.980642

2780.9068
6289.3940

2762.9795
6284.2338

2714.9304
5270.4034

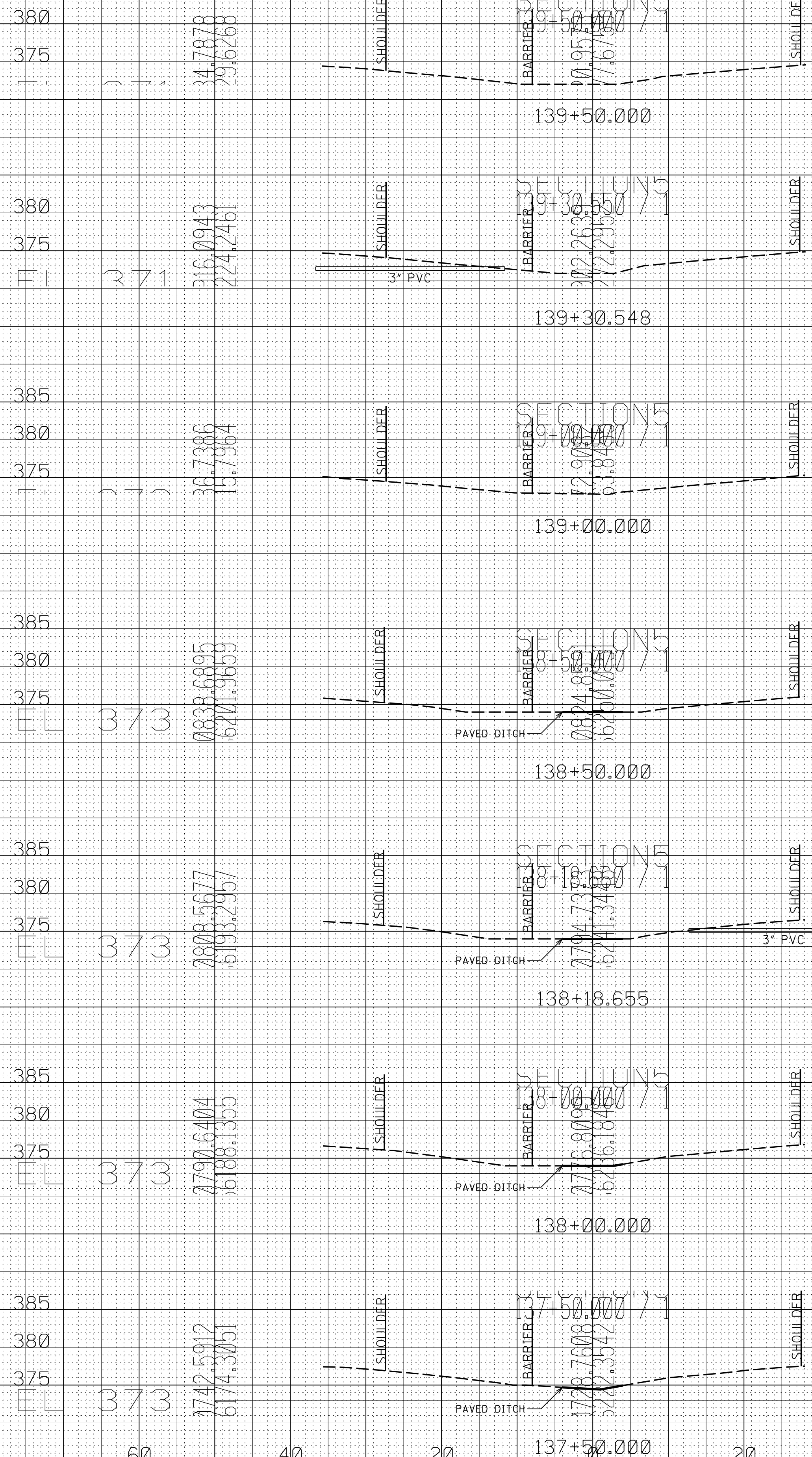

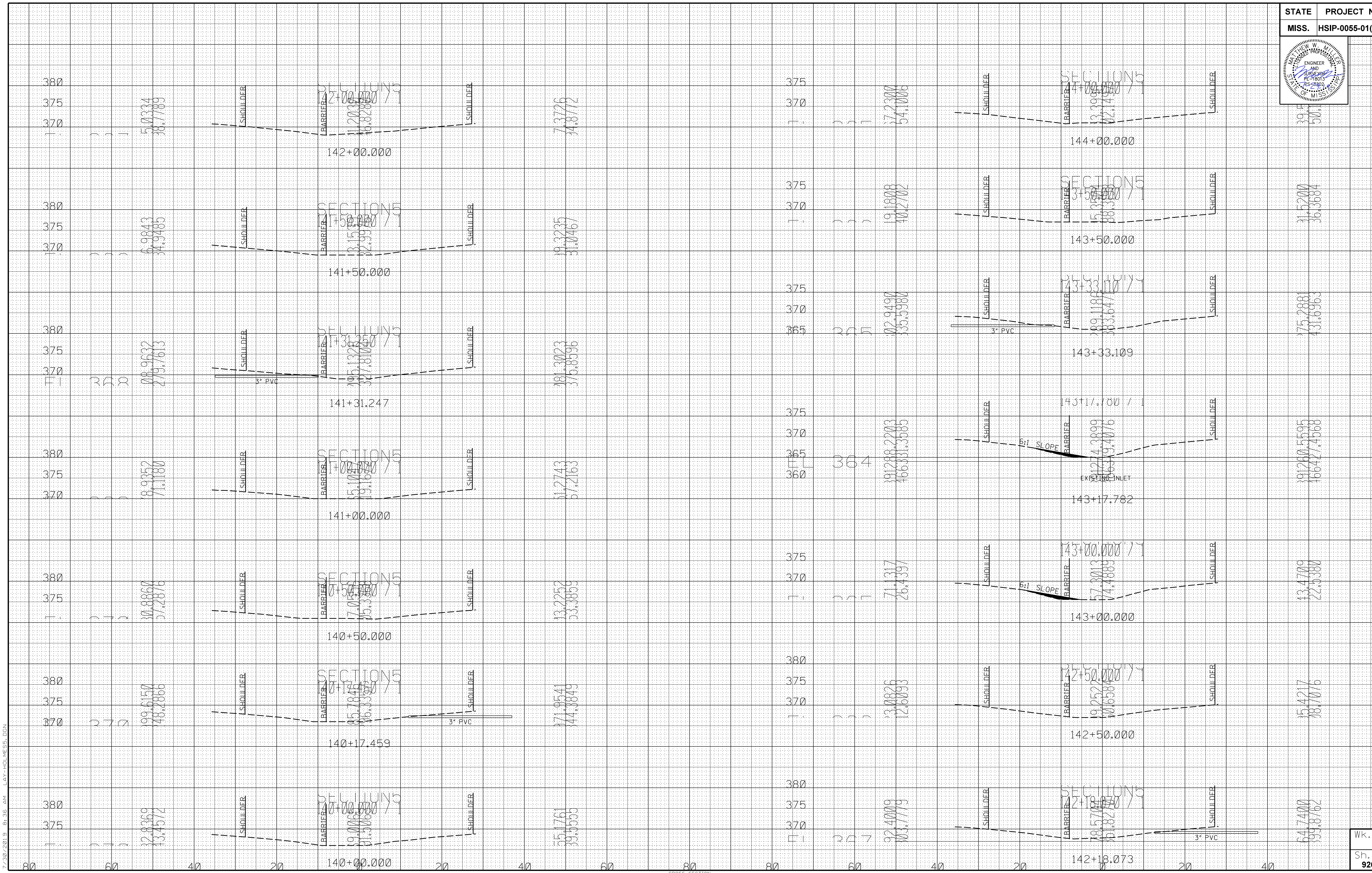
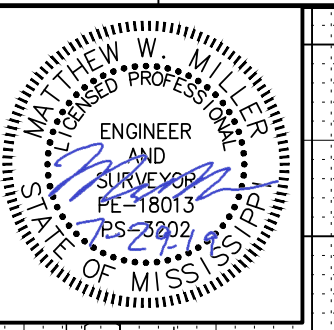

7/26/2019 8:36 AM LAY-HOLMES.DGN

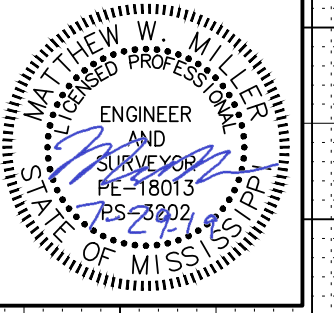

7/26/2019 8:36 AM LAY-HOLMES.DGN

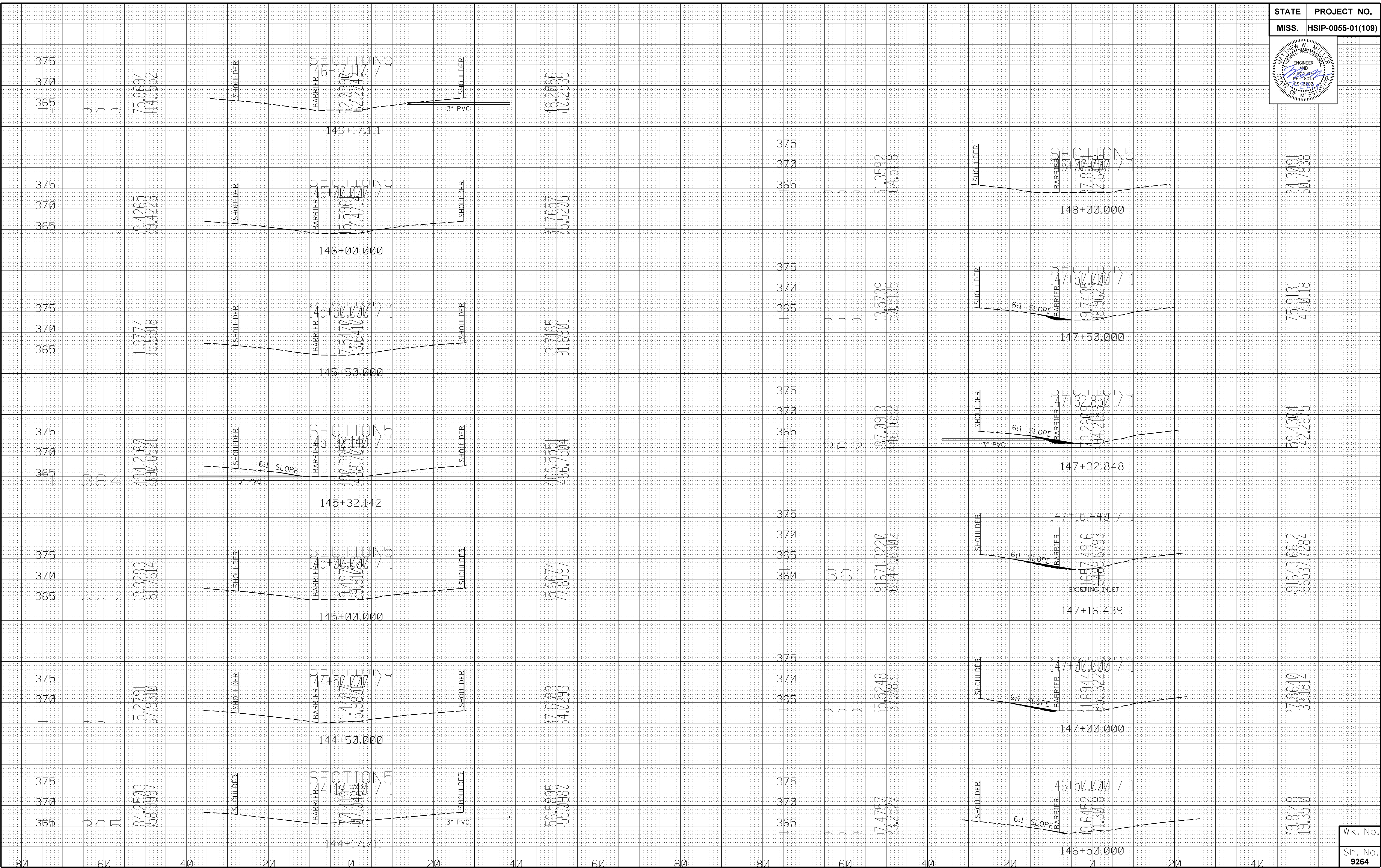

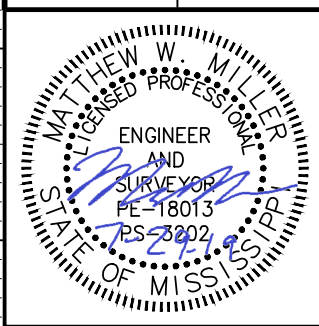

7/30/2019 8:36 AM LAT-HOL.MESS.DGN

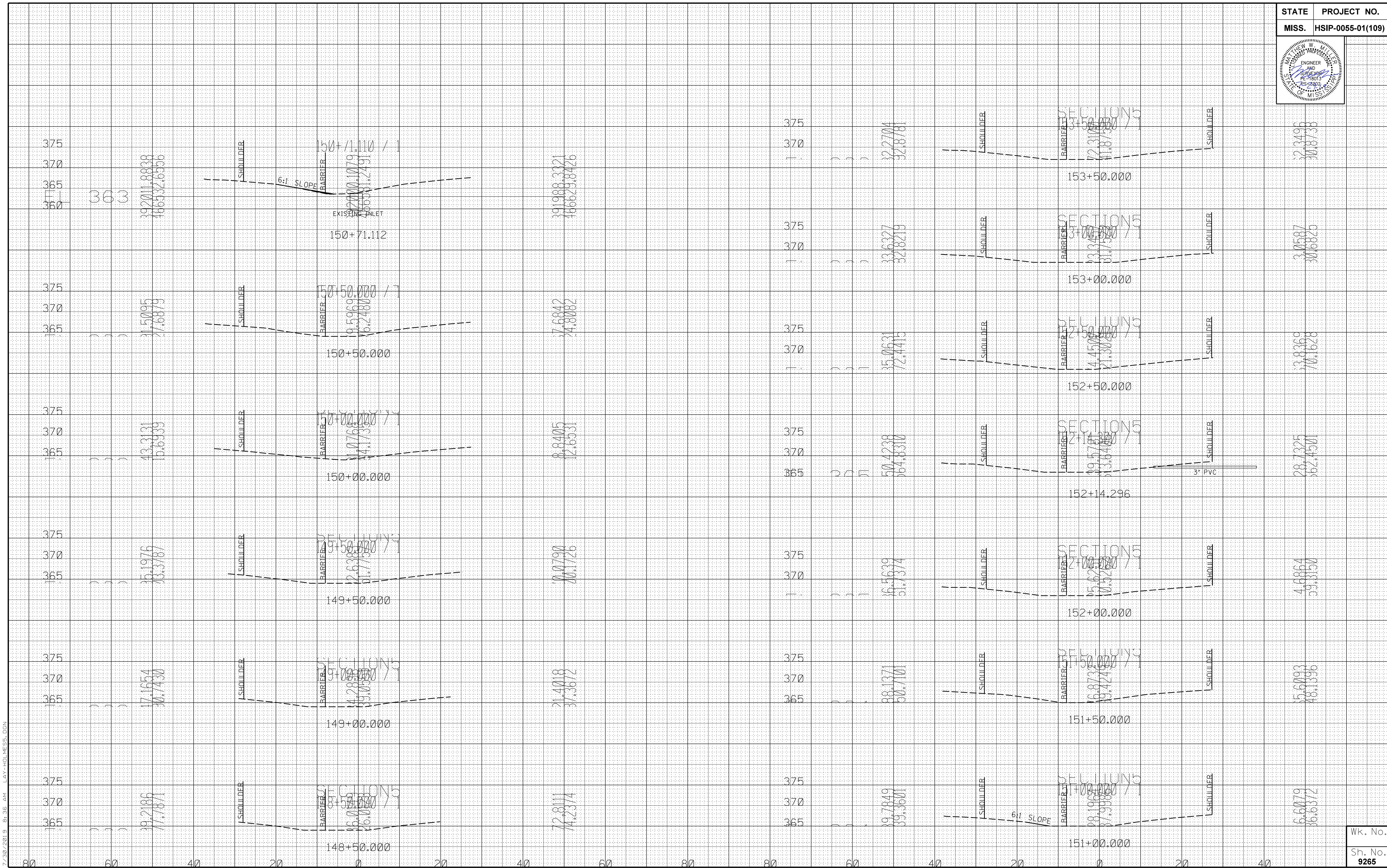

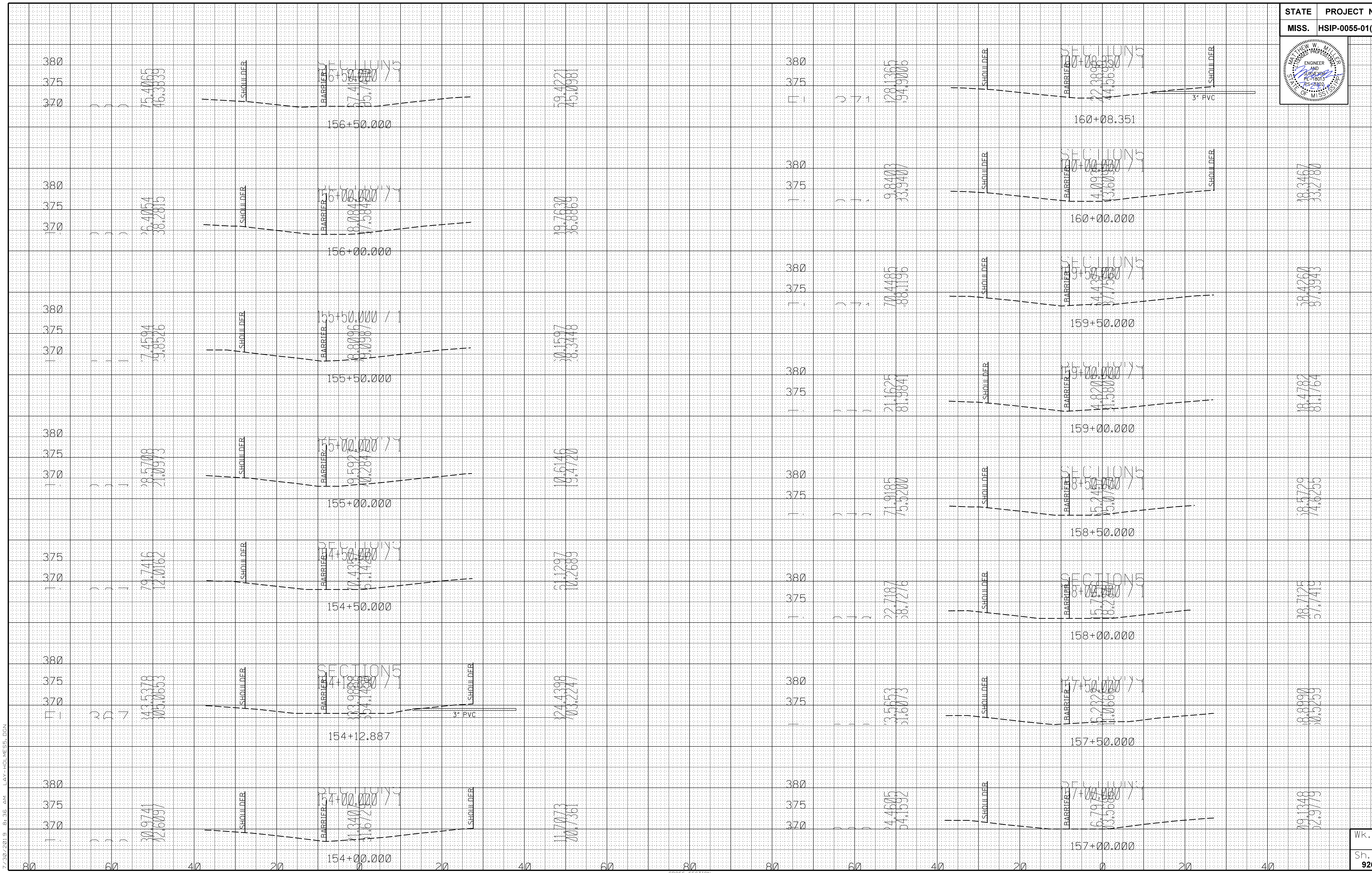
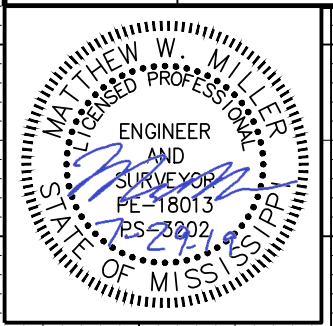

7/26/2019 8:36 AM LAT-HOL.ME55.DGN

7/26/2019 8:36 AM LAT-HOL.MESS.DGN

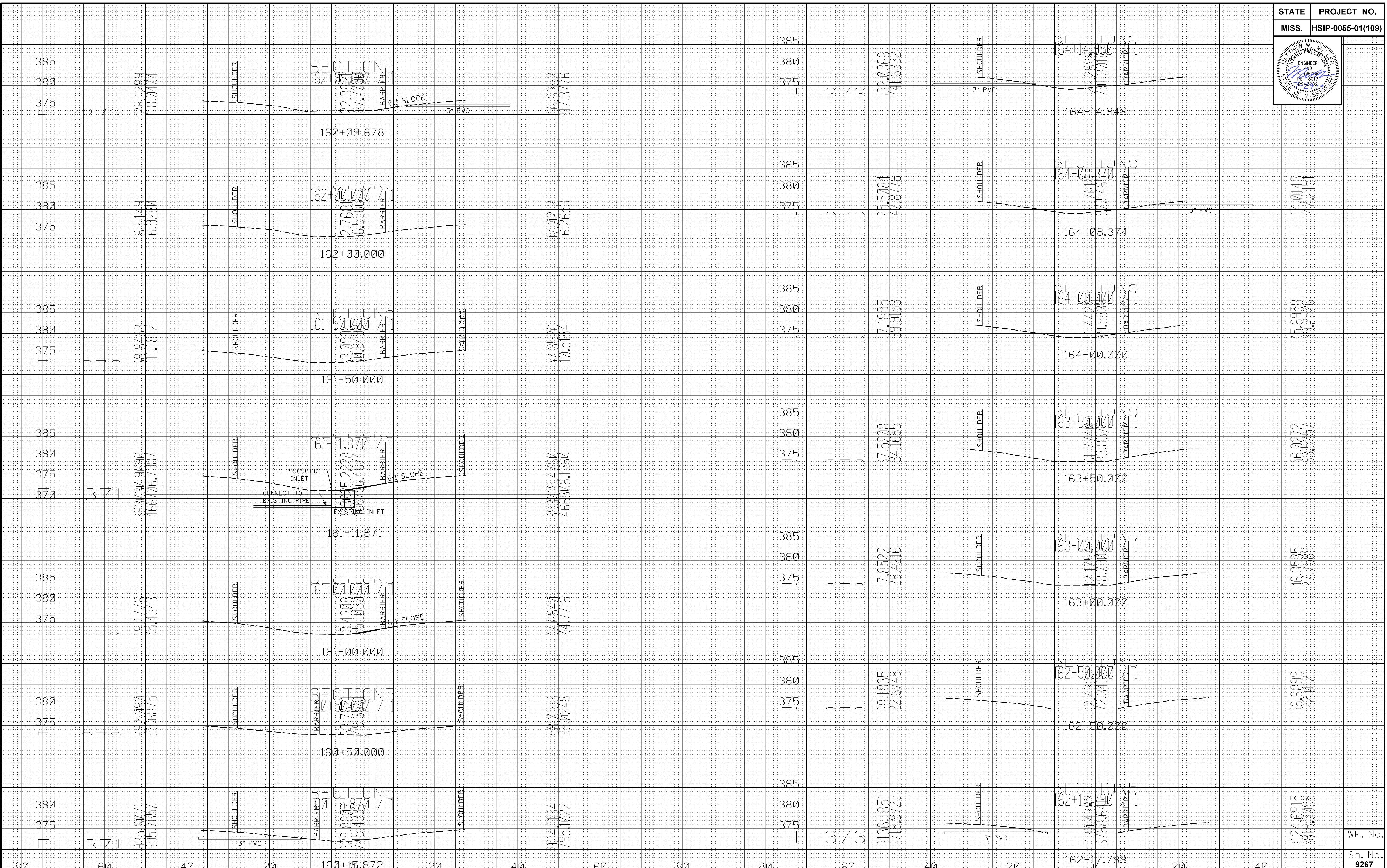

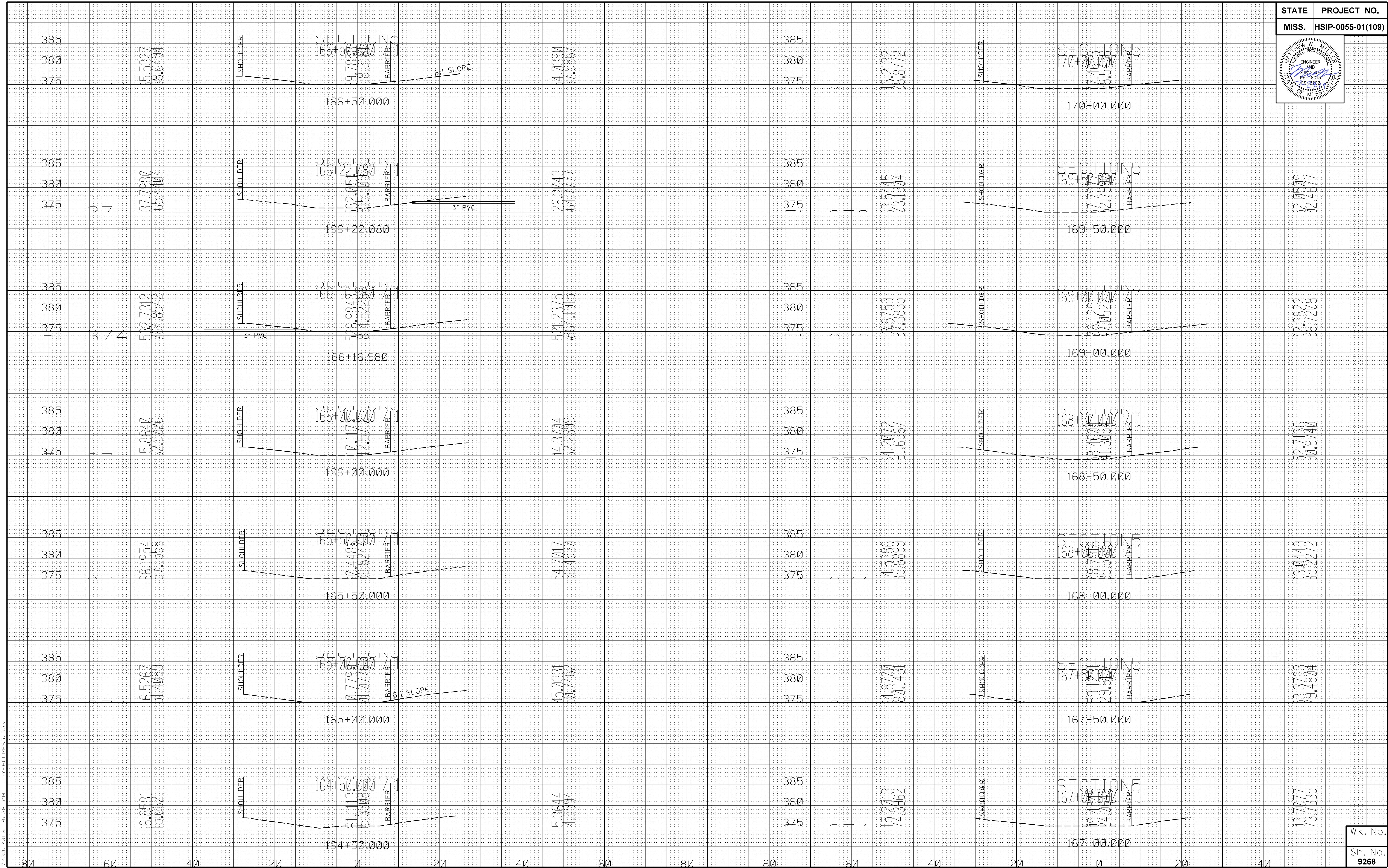
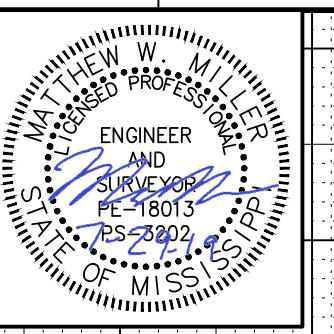

7/30/2019 8:36 AM LAT-HOLMESS.DGN

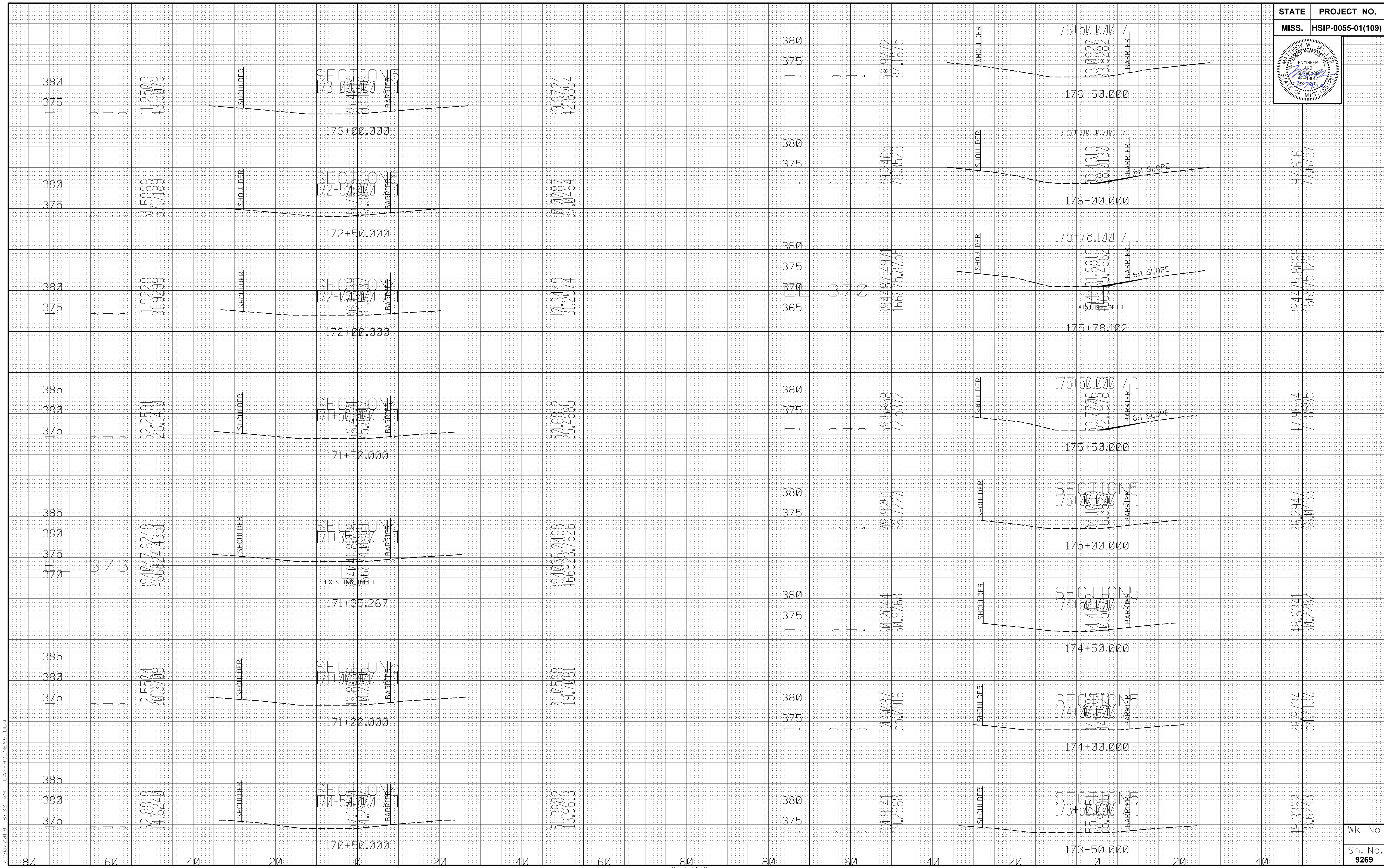

7/26/2019 8:36 AM LAT-HOLMES.DGN

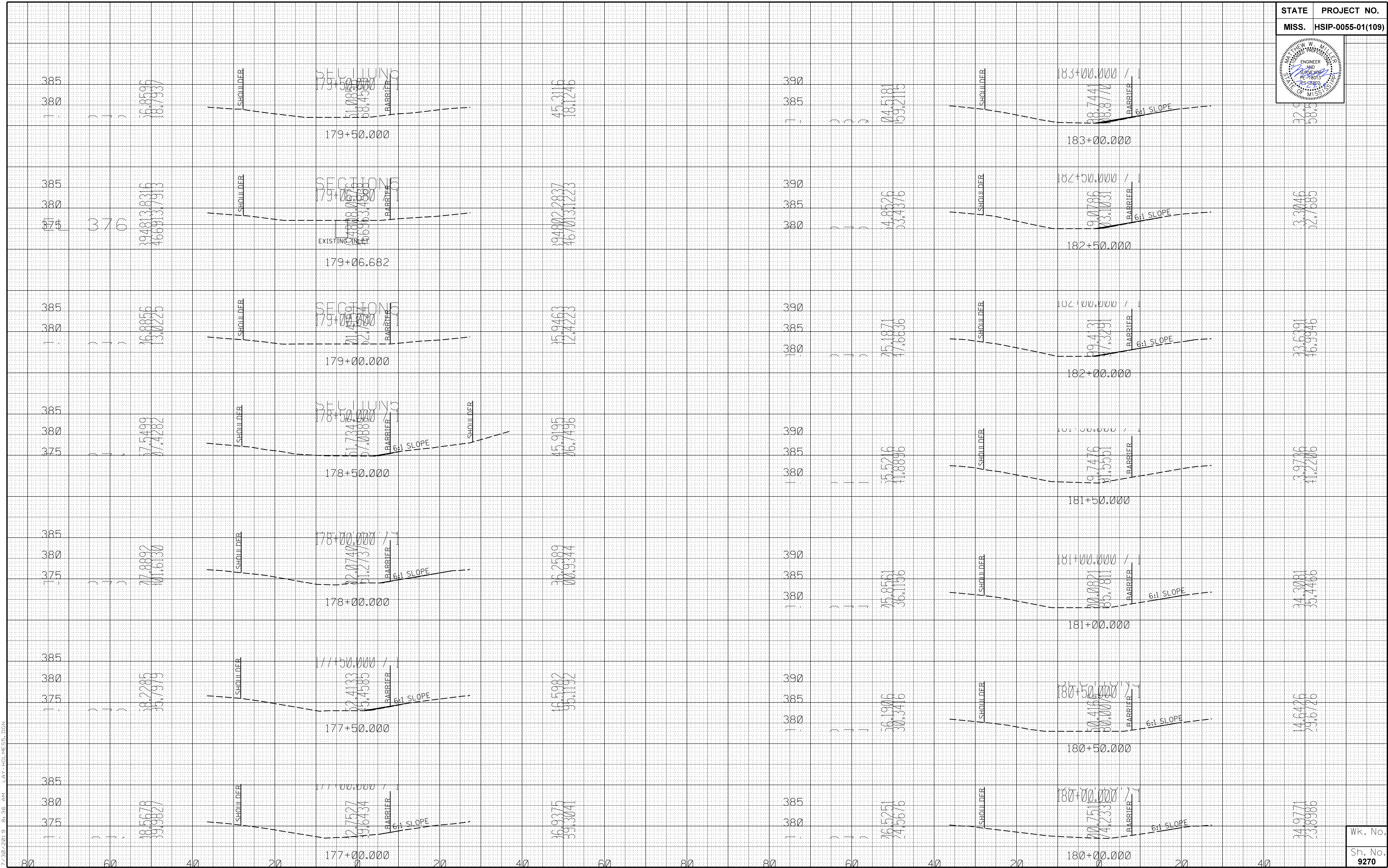
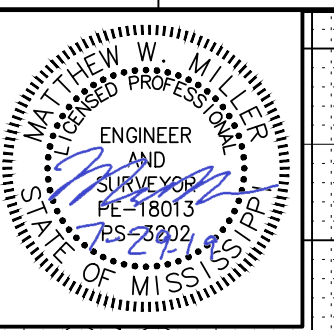

7/30/2019 8:36 AM LAT-HOL.MESS.DGN

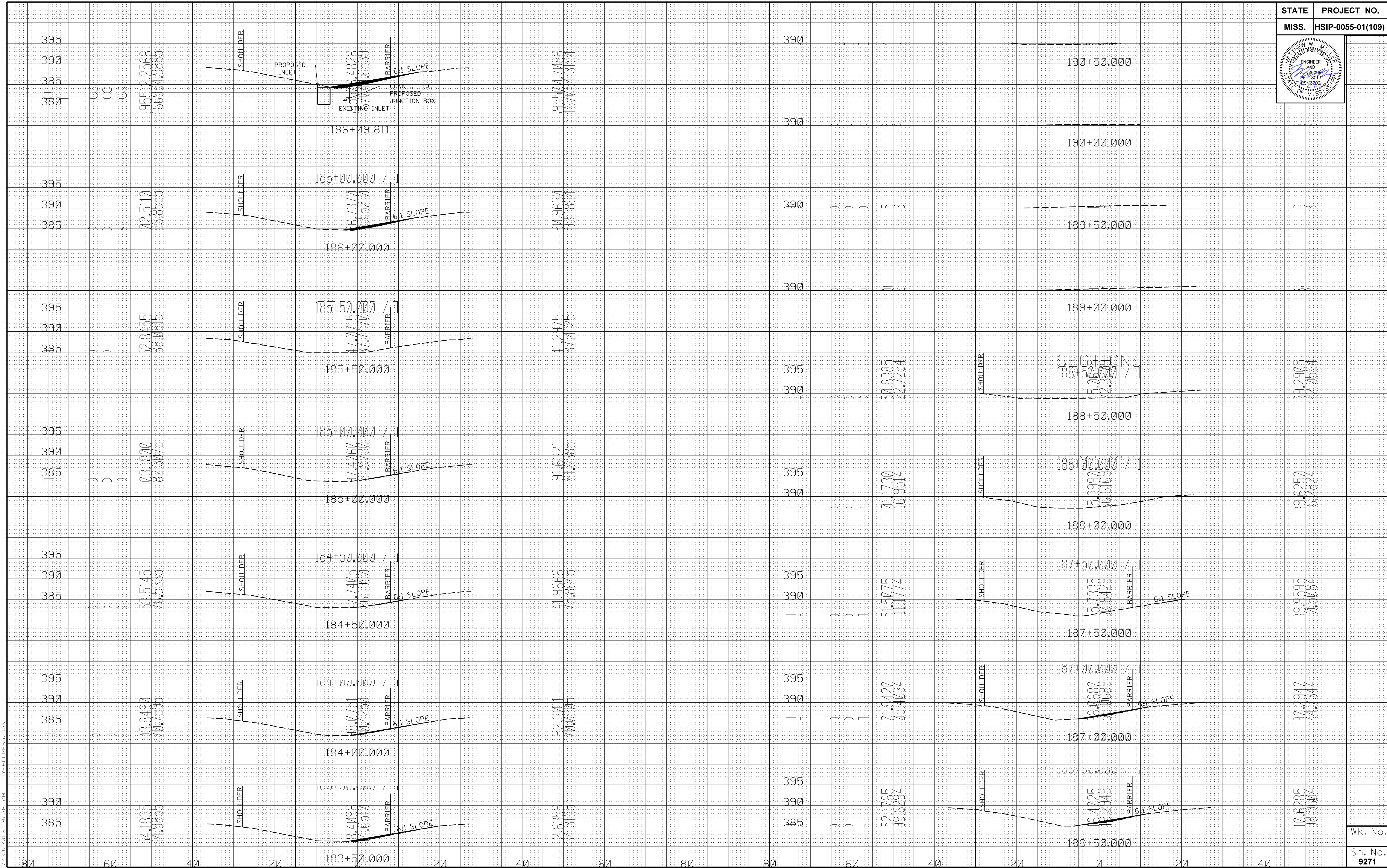
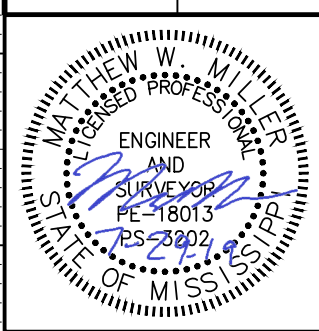

7/26/2019 8:36 AM LAY-HOLMES.DGN

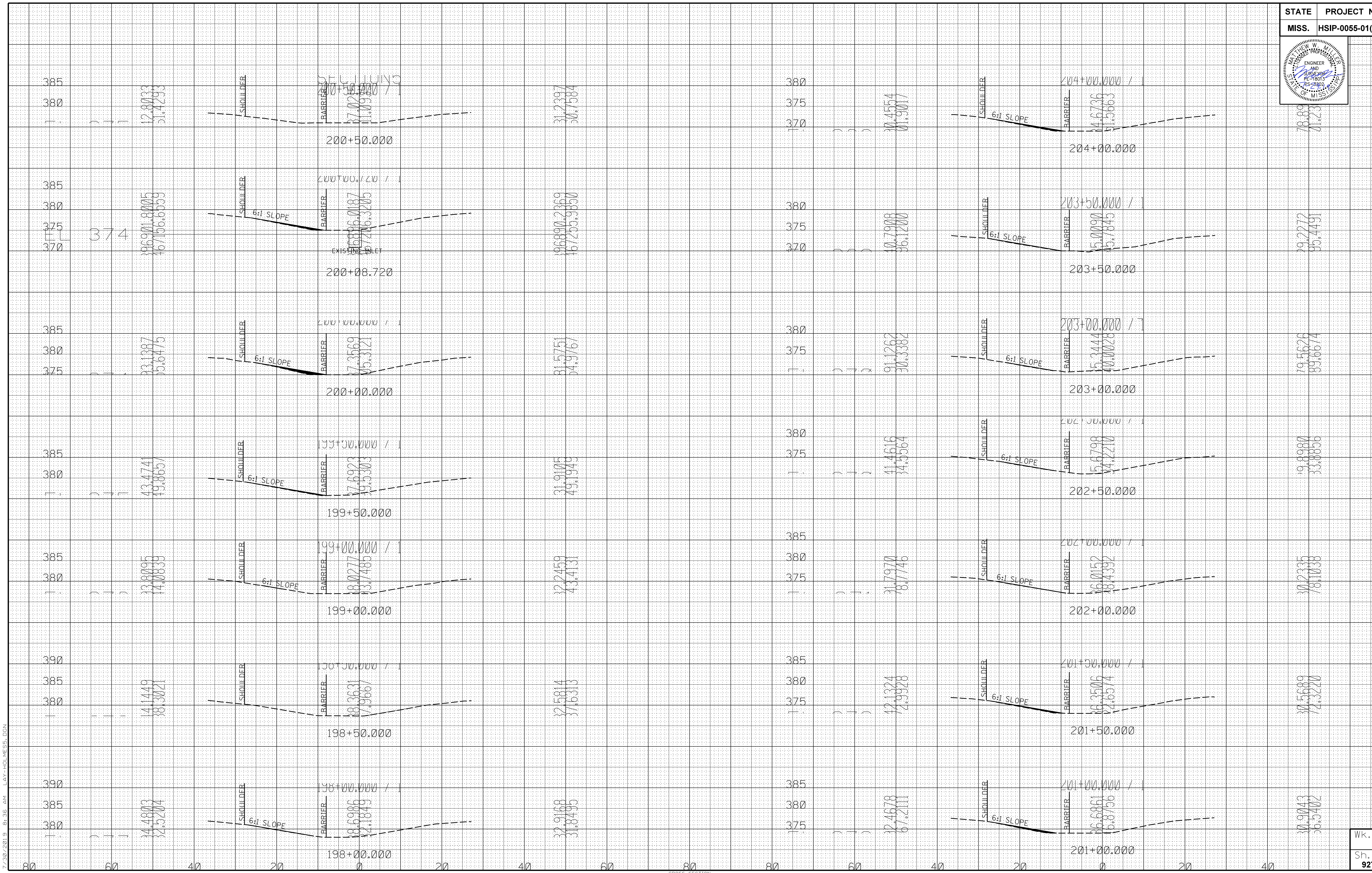
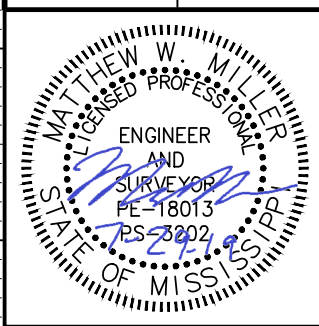

7/30/2019 8:36 AM LAT-HOLMESS.DGN

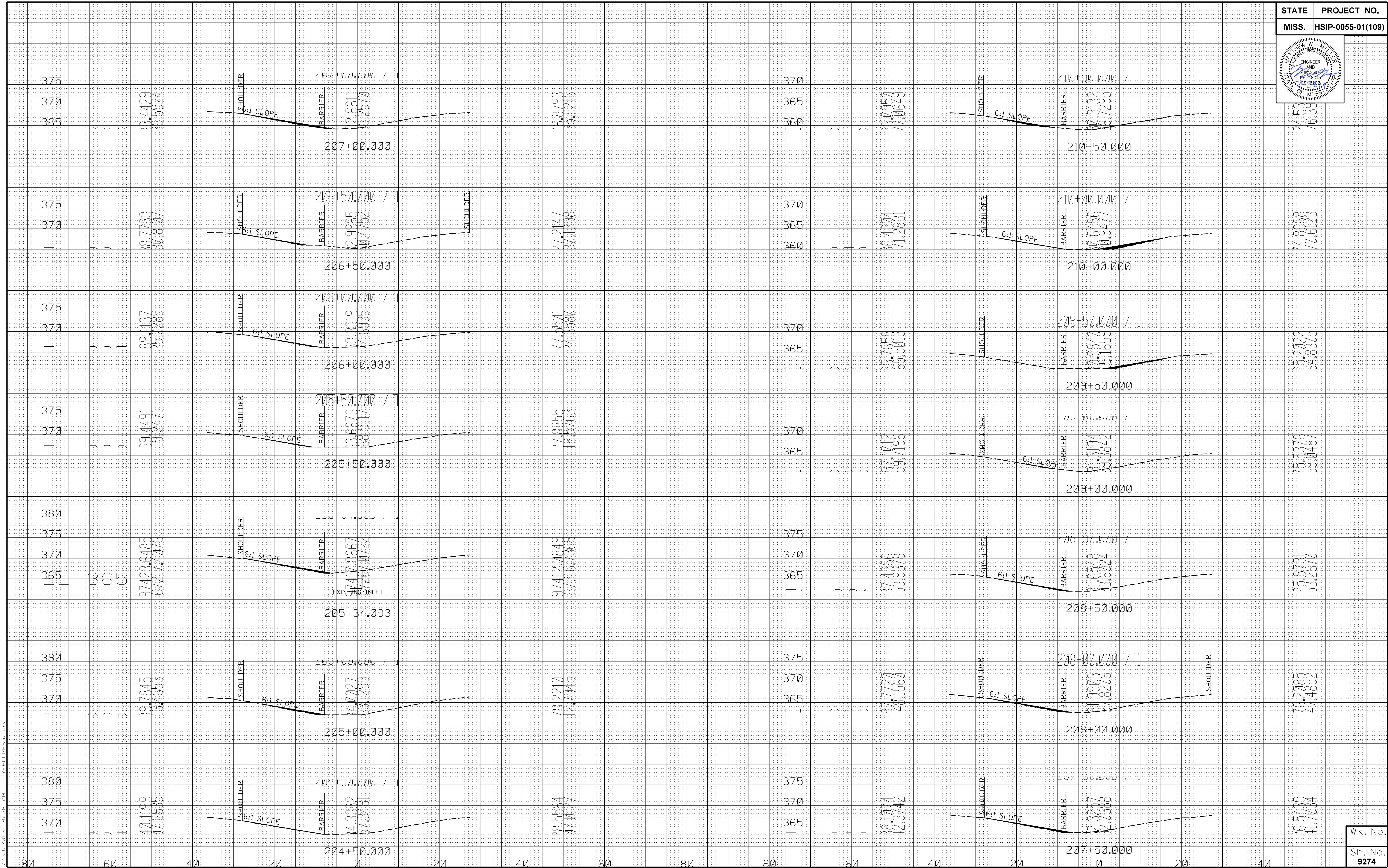
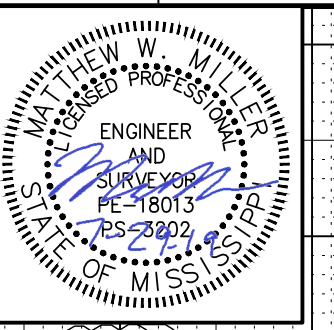

7/30/2019 8:36 AM LAT-HOL.ME55.DGN

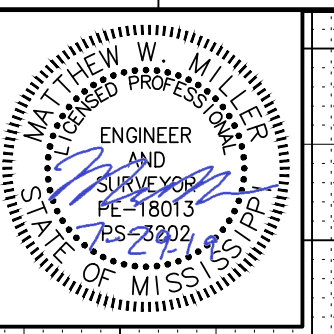

7/30/2019 8:36 AM LAT-HOLMES.DGN

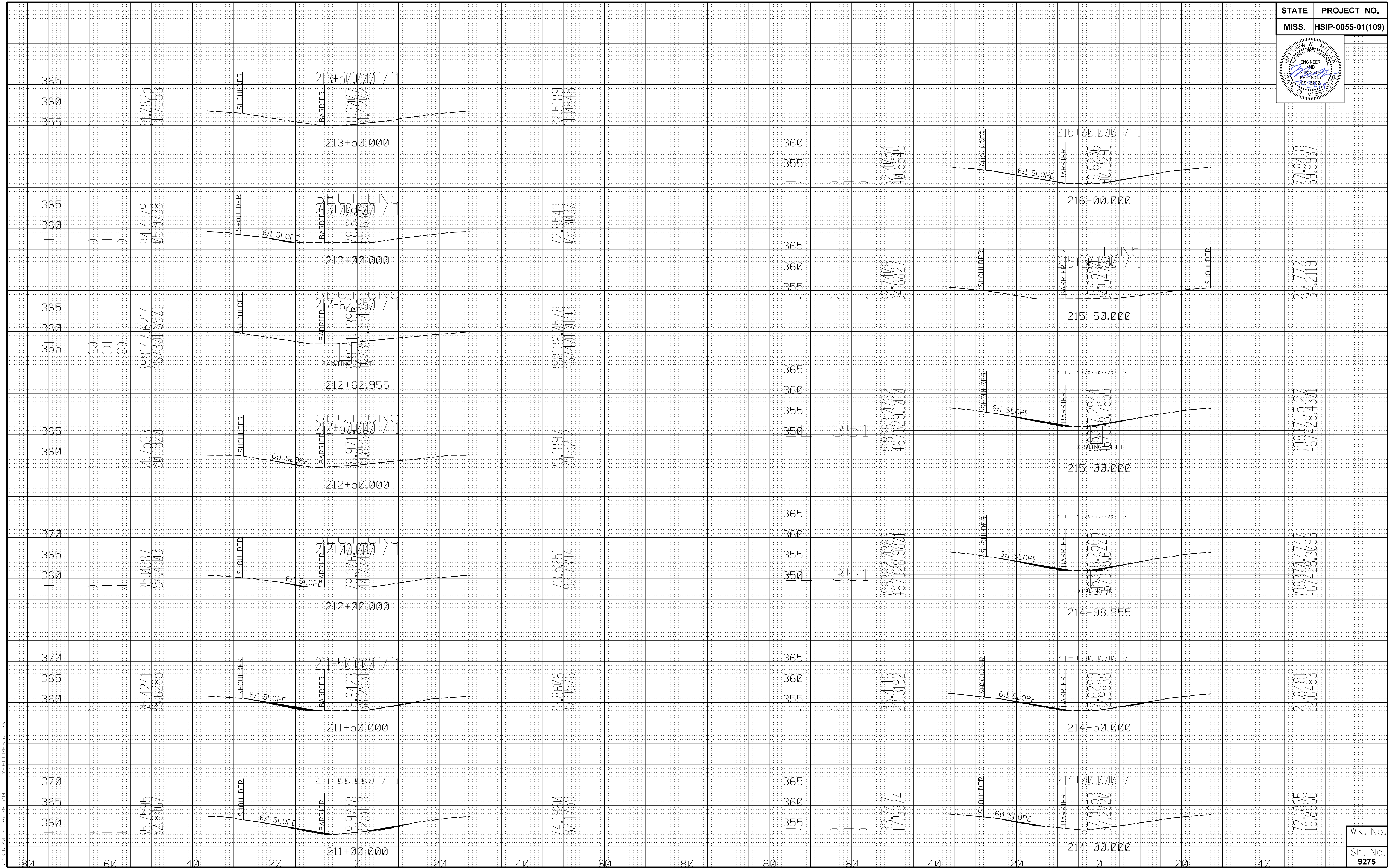

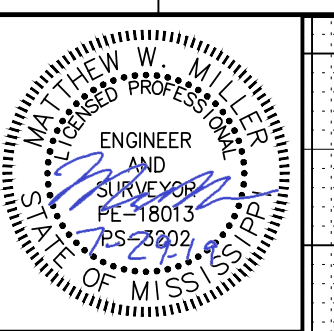

7/30/2019 8:36 AM LAT-HOLMES.DGN

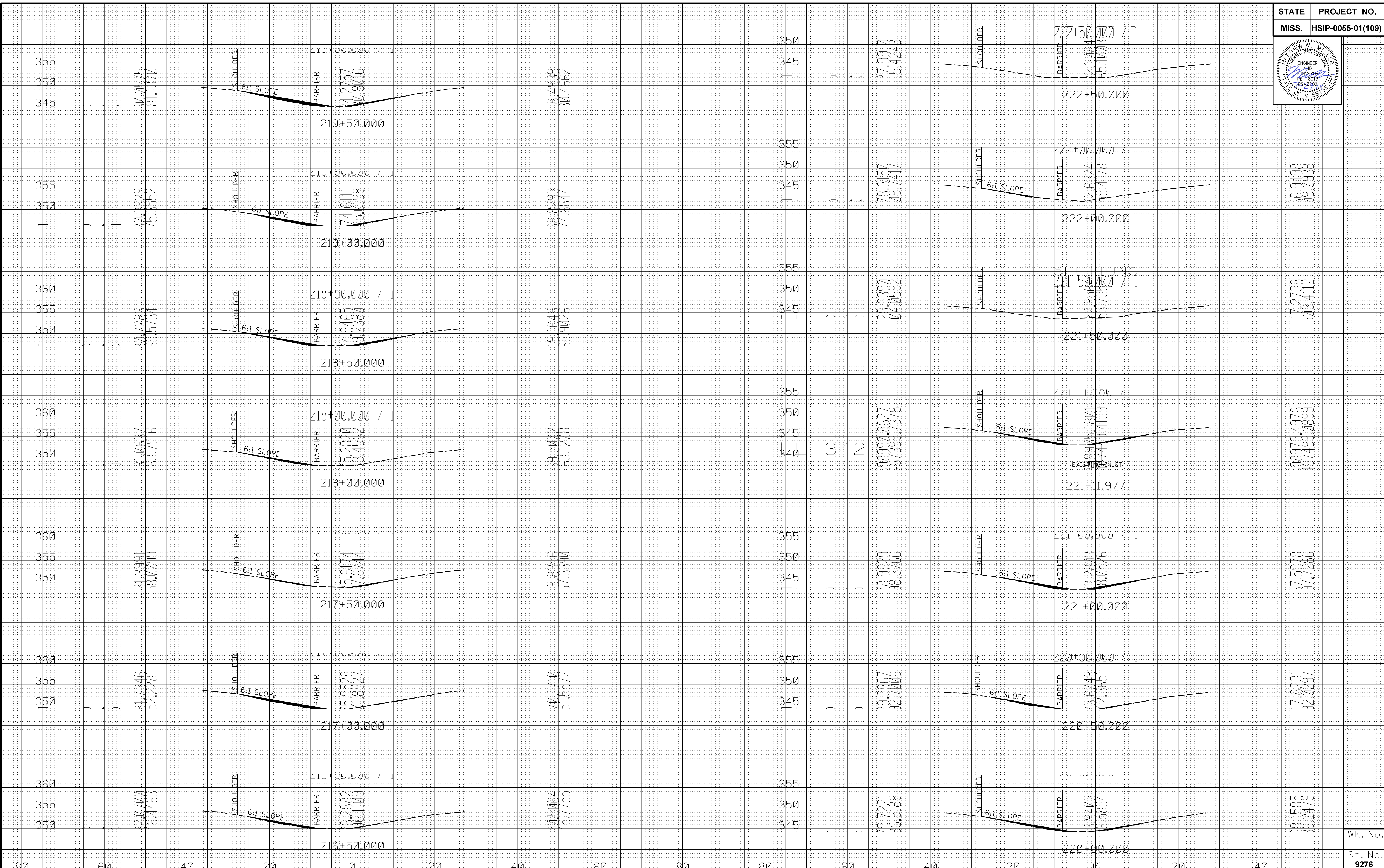

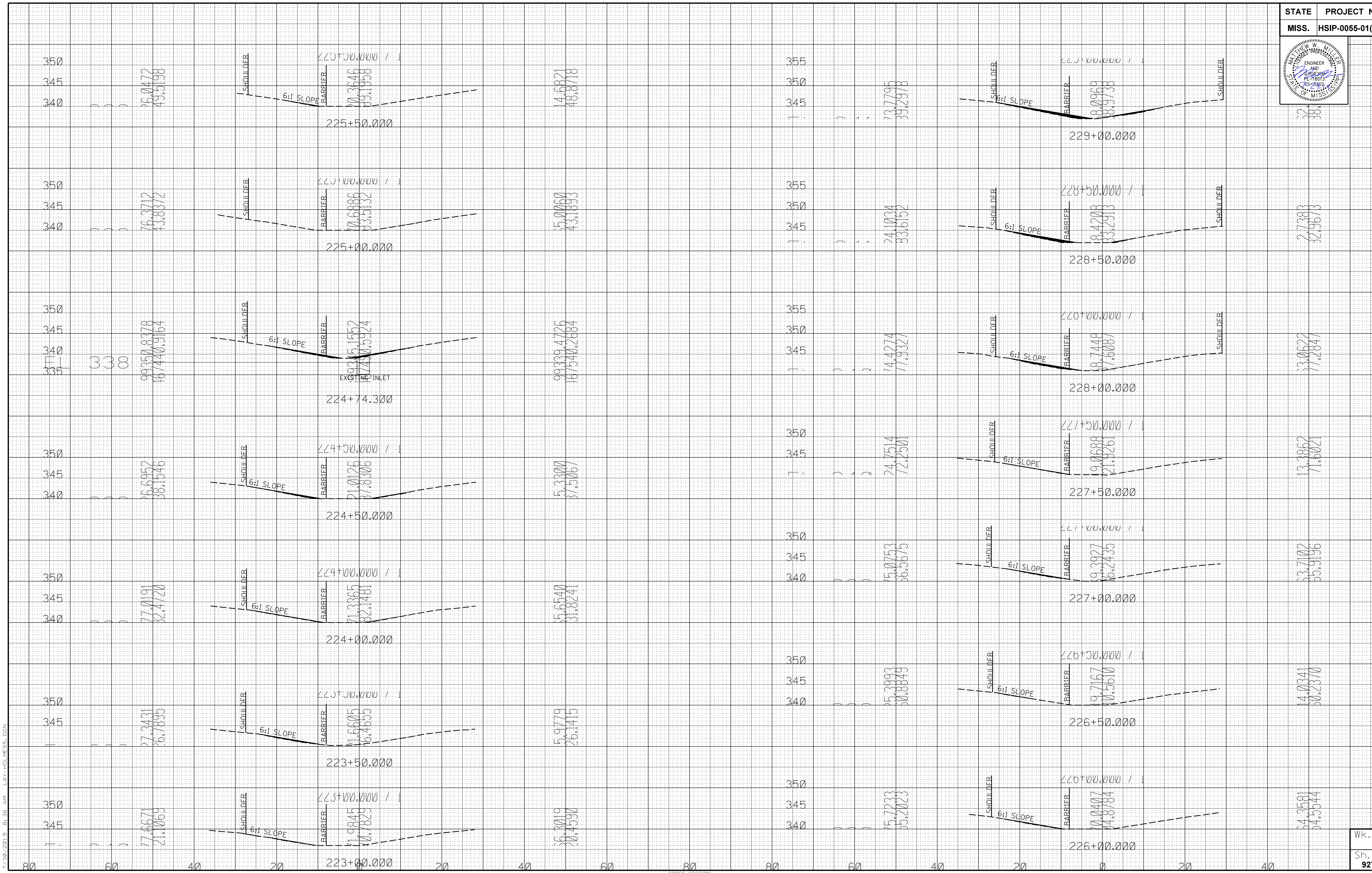
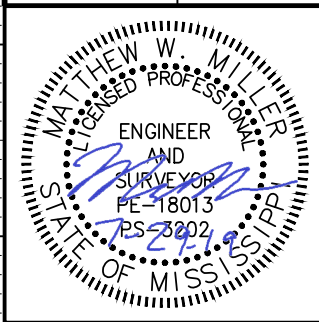

7/30/2019 8:36 AM LAT-HOLMES.DGN

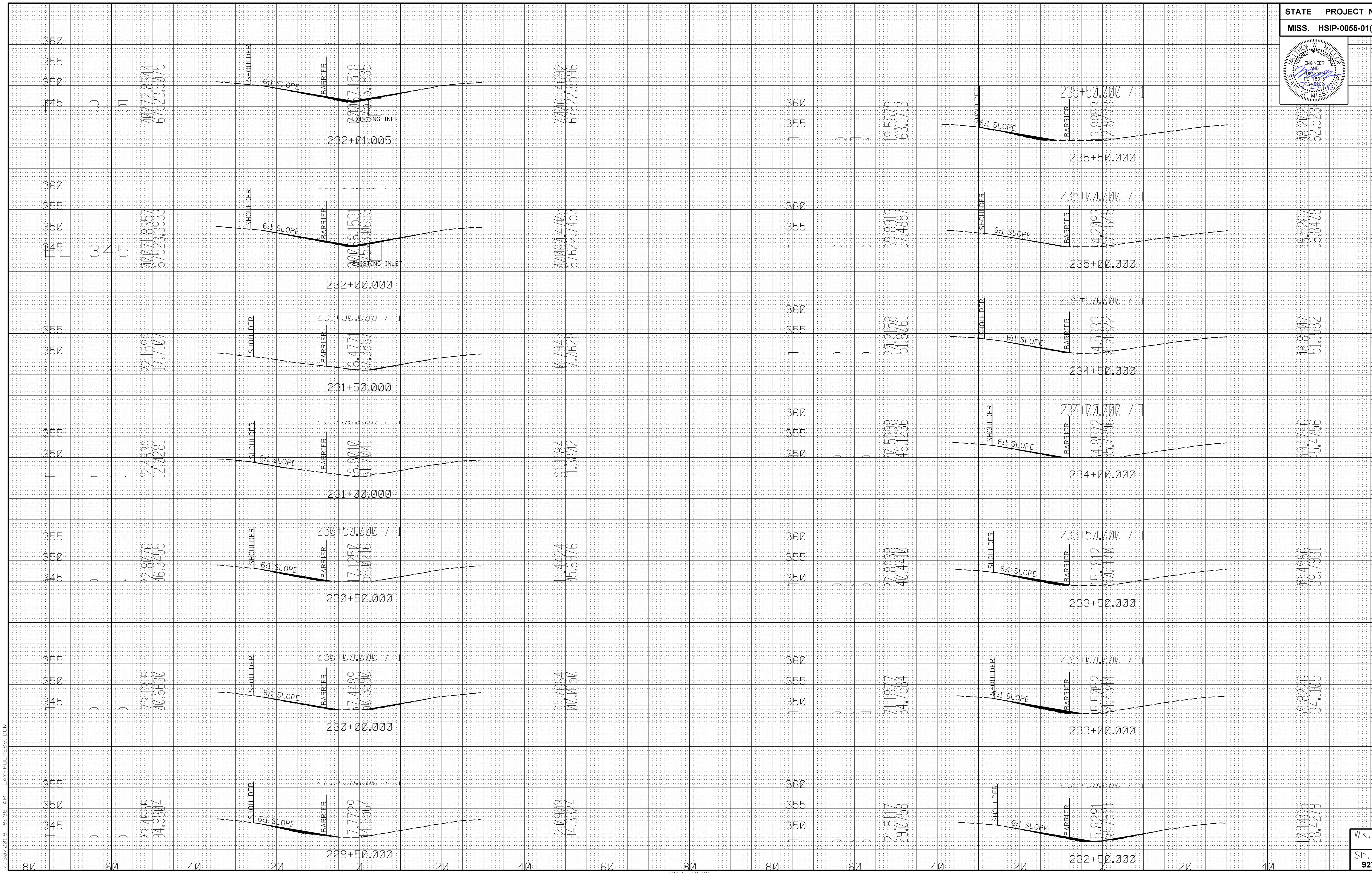
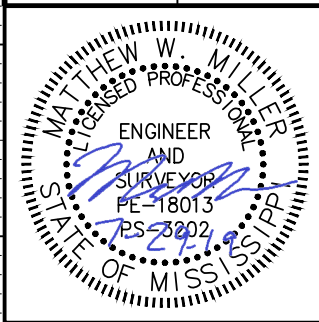

7/30/2019 8:36 AM LAT-HOL.MESS.DGN

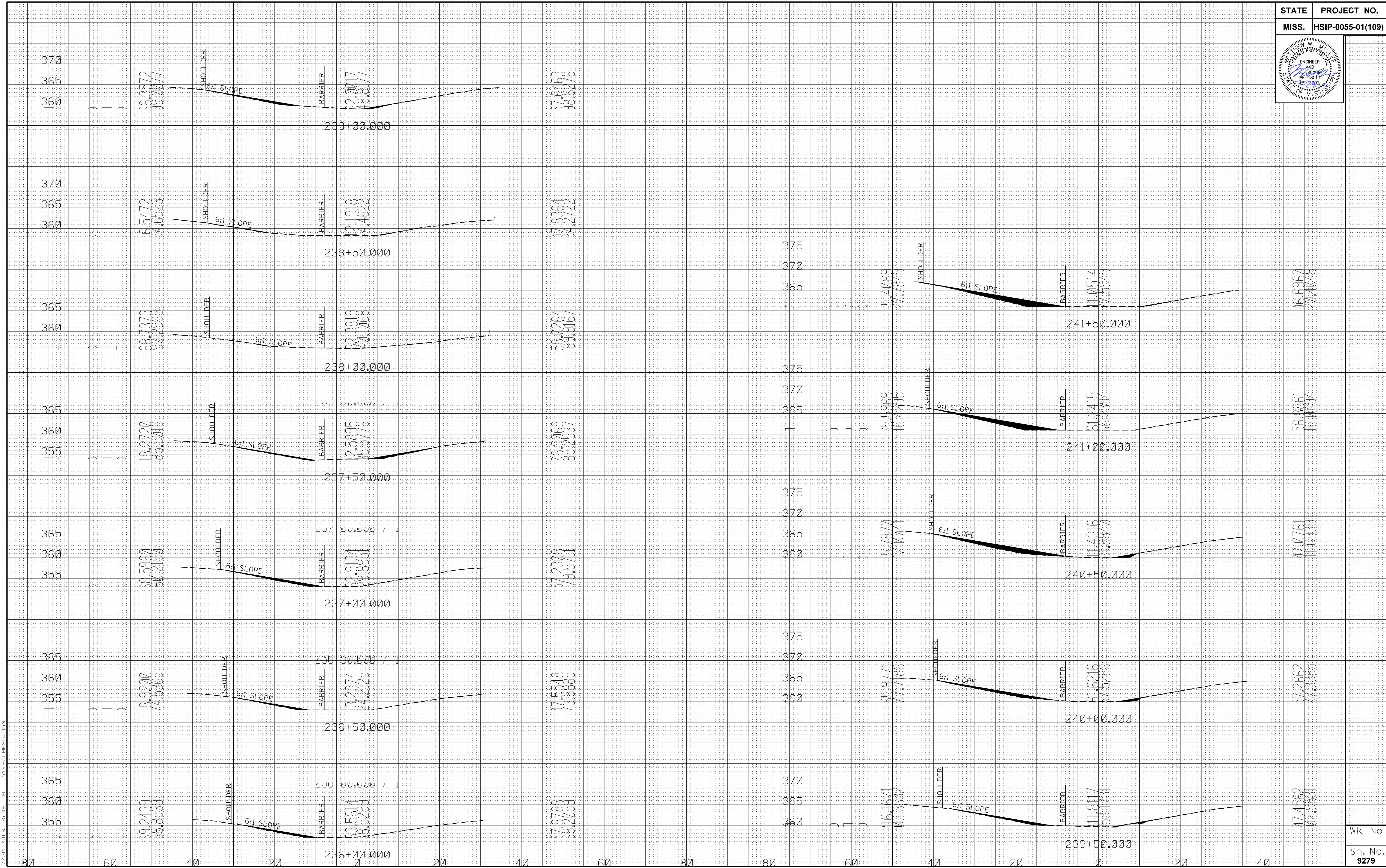
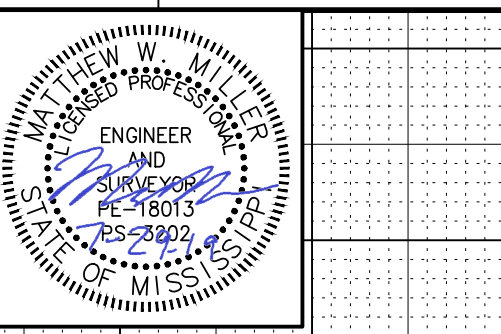

7/30/2019 8:36 AM LAY-HOLMESS.DGN