

Panola 310
BR-0834-00(022); 106967-301000

Section 404 Nationwide 23 and
Section 401 Water Quality

Location Maps

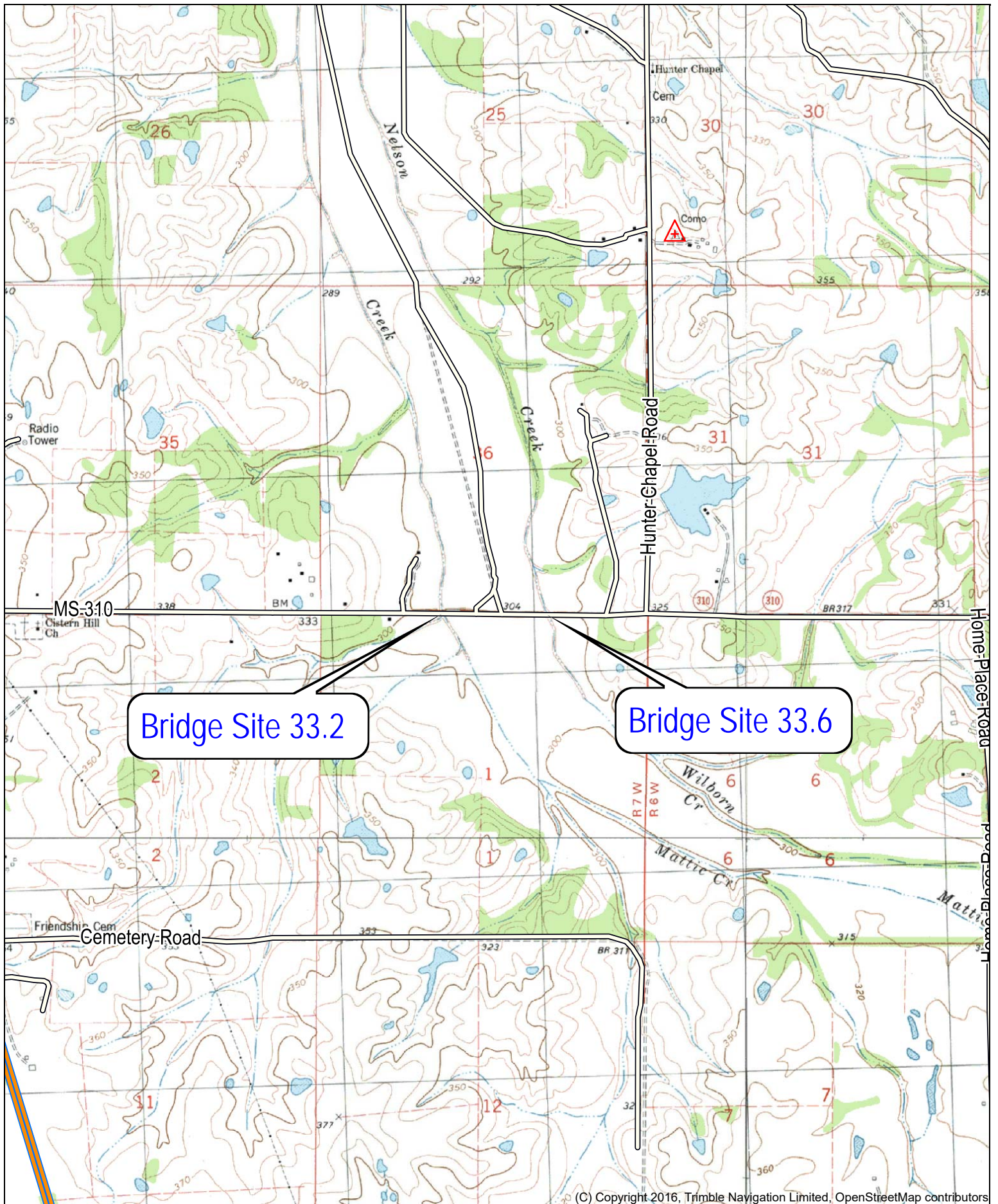

(C) Copyright 2016, Trimble Navigation Limited, OpenStreetMap contributors

Name: SENATOBIA
 Date: 07/10/20
 Scale: 1 inch = 2,000 ft.

Location: 034° 30' 37.0477" N, 089° 53' 18.1497" W
 Panola 310 bridge replacements
 FMS: 106967/301000

Datum: NAD27

Table of Impacts

Table 1. Wetland Data Point Summary Table

Data Point	Wetland ID#	Site # OR Worksheet #	Latitude	Longitude	Station	Section-Township-Range	Area from ROW to ROW (Acres)	Cowardin Classification	Impact
DP-2	W-1	1	34.5105	-89.8937	112+00	36-6S-7W	0.74	PFO	0.42 acres temporary clearing 0.32 acres permanent fill

DP - Data point- collection point for sampling data for wetland assessment

W – Wetland areas described as wetlands

PFO – Palustrine Forested

PEM – Palustrine Emergent

PSS – Palustrine Shrub-Scrub

Station Numbers are approximate

**Latitude and Longitude in Decimal Degrees, NAD 83, State Plane*

Wetland Summary:	Total Present (acres)	Permanent Fill (acres)	Temporary Fill (acres)
Forested	0.74	0.32	0.42
Shrub-Scrub	0	0	0
Emergent	0	0	0
Total	0.74	0.32	0.42

Table 2. Channel Assessment Table

CA #	Site #/ OR Worksheet #	Latitude	Longitude	Section-Township-Range	Station	Type	Length in Project Area (feet)	Channel Width (feet)	Name	Impact
3	1	34.5102	-89.8916	36-6S-7W	119+56.73	P	387.82	45	Mattic Creek	41.17 ft. – New bridge width
4	1	34.5100	-89.8916	1-7S-7W	118+80	P	178.94	12	Unnamed	No Impacts
9	1	34.5106	-89.8859	36-6S-7W	134+47.59	P	503.37	25	Nelson Creek	45.09 ft. – New bridge width
11	1	34.5102	-89.8850	36-6S-7W	142+82	I	1006.36	2	Unnamed	958.86 ft. – Fill channel and relocate

CA- Channel Assessment- Channel Assessment point location

Type:

P-Perennial

I-Intermittent

E-Ephemeral

OHWM-Ordinary High Water Mark

Station numbers (Sta.) are approximate

CA Summary:	Total Present (feet)	New Bridge Width Shade/Clear (ft)	Temporary Bridge Width Shade/Clear (ft)	Culvert/ Pipe (ft)	Rip-Rap/ Armor (ft)	Relocate and Fill (ft)	New Channel with Rip-Rap (ft)
Perennial	86.26	86.26	0	0	0	0	0
Intermittent	958.86	0	0	0	0	958.86	0
Ephemeral	0.00	0	0	0	0	0	0
Total	1045.12	86.26	0	0	0	958.86	0

Note: Sheet ECD-17 will be included with the plans.

Roadway and Bridge Plans

STATE OF MISSISSIPPI

MISSISSIPPI DEPARTMENT OF TRANSPORTATION

PLAN AND PROFILE OF PROPOSED
STATE HIGHWAY
FEDERAL AID PROJECT NO. BR-0834-00(022)

BRIDGE REPLACEMENT
S.R. 310
PANOLA COUNTY

FMS CON. NO. 106967/301000

R.O.W. FMS	106967/201000
PLANS STAGE	DATE PRINTED
<input type="checkbox"/> CONCEPTUAL	
<input type="checkbox"/> PRE-R.O.W.	04/05/16
<input type="checkbox"/> FIELD INSPECTION	09/15/16
<input type="checkbox"/> R.O.W. PLANS TO SMD	08/31/17
<input type="checkbox"/> FINAL R.O.W.	12/06/17
<input type="checkbox"/> R.O.W. REVISION	
<input checked="" type="checkbox"/> OFFICE REVIEW	07/31/20

STATE	PROJECT NUMBER	SHEET NO.
MISSISSIPPI	BR-0834-00(022)	1

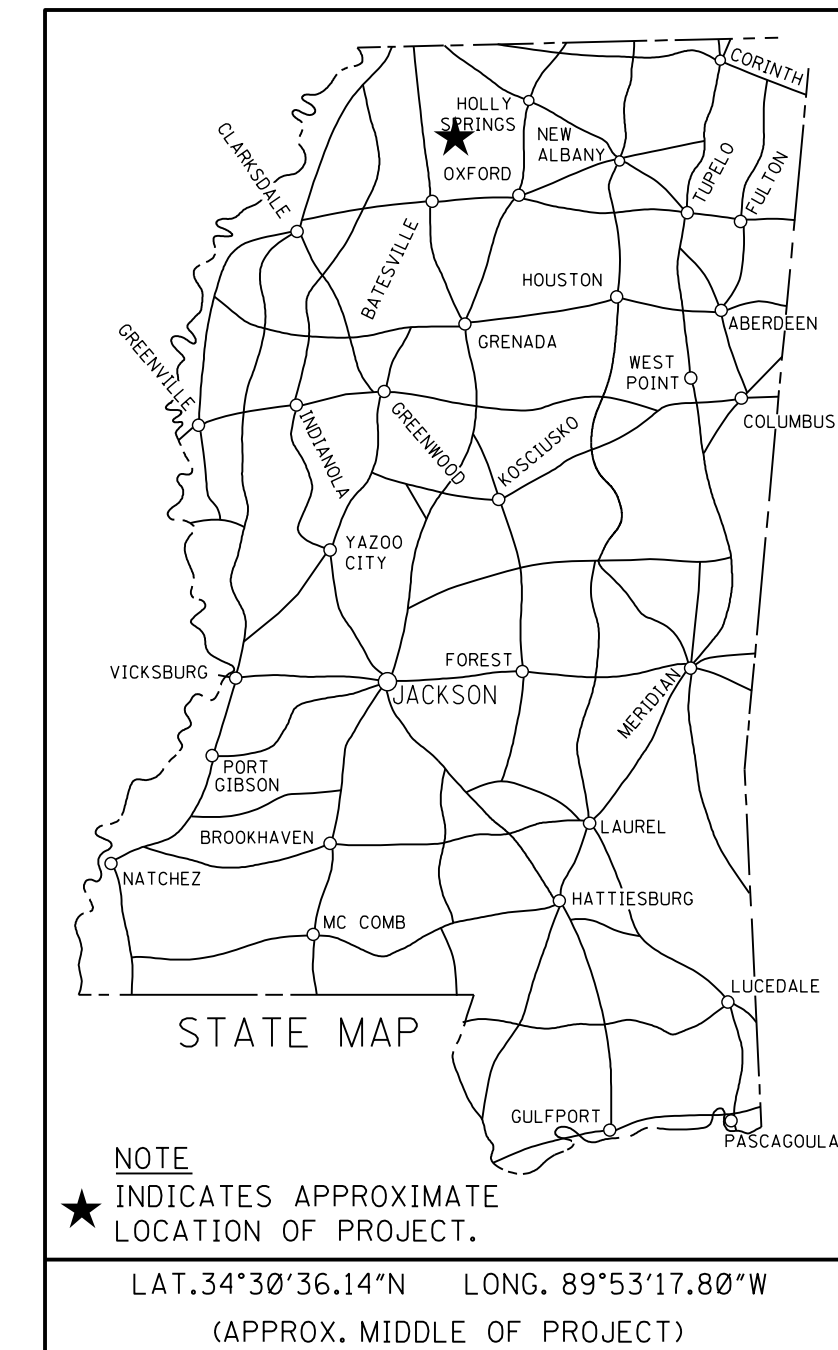

GENERAL INDEX

INCLUDED THIS PROJECT	BEGIN WITH SHEET
<input checked="" type="checkbox"/> ROADWAY	1
<input checked="" type="checkbox"/> PERMANENT SIGNS	1001
<input type="checkbox"/> TRAFFIC SIGNALS	2001
<input type="checkbox"/> ITS COMPONENTS	3001
<input type="checkbox"/> LIGHTING	4001
<input type="checkbox"/> (RESERVED)	5001
<input checked="" type="checkbox"/> ROADWAY STANDARD DWGS	6001
<input checked="" type="checkbox"/> BRIDGE STD. DRAWINGS	7001
<input type="checkbox"/> BOX CULVERT STD. DRAWINGS (STD. SPEC.)	7501
<input checked="" type="checkbox"/> BRIDGE	8001
<input checked="" type="checkbox"/> CROSS SECTIONS	9001

BRIDGE STRUCTURES REQ'D.

BR 33.2
STA. 117+52 TO STA. 120+87
SPANS: 1@100'; 1@135'; 1@100'

BR 33.6
STA. 134+24 TO STA. 137+59
SPANS: 1@100'; 1@135'; 1@100'

BOX BRIDGES REQ'D.

NONE

SCALES

PLAN	1 IN. = 100 FT.
PROFILE	HOR. 1 IN. = 100 FT.
	VERT. 1 IN. = 10 FT.
LAYOUT	1 IN. = 5855.0 FT.

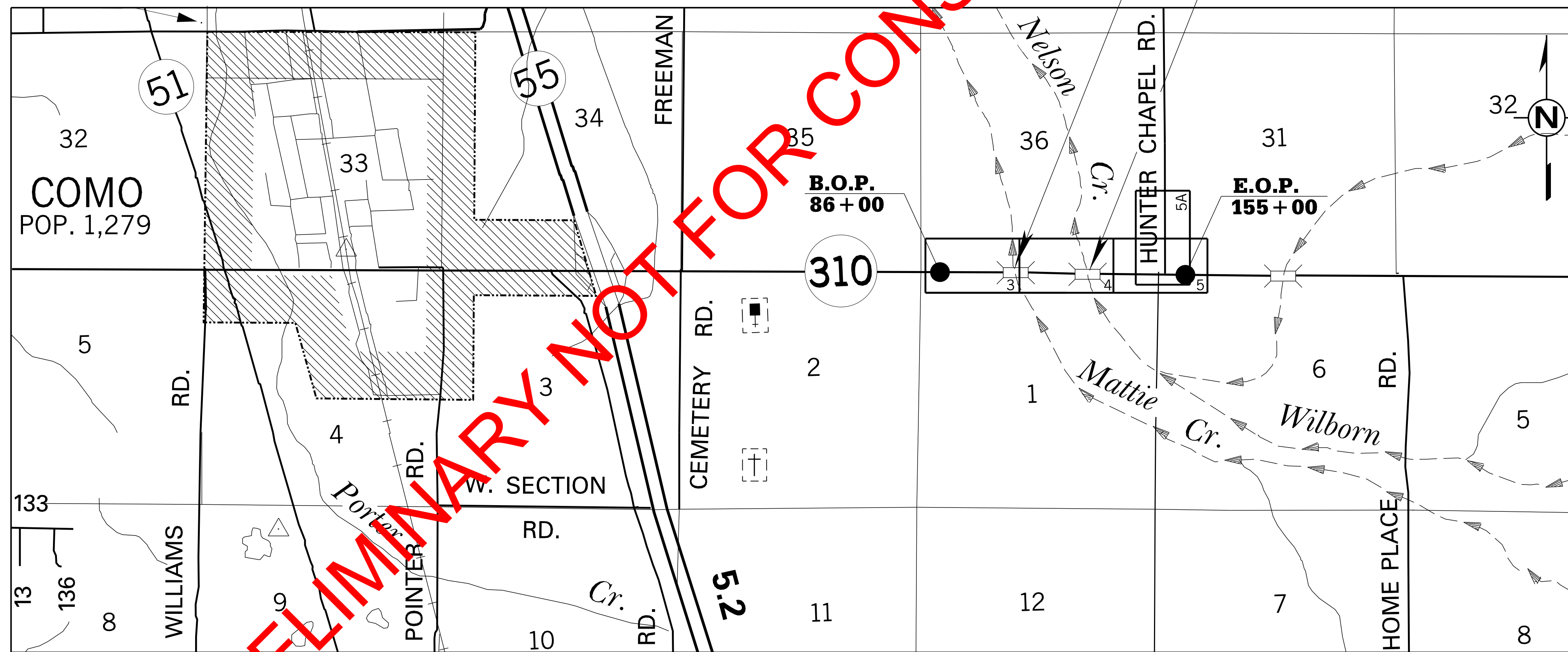

PRELIMINARY NOT FOR CONSTRUCTION

CONVENTIONAL SYMBOLS

COUNTY LINE	-----
TOWN CORPORATION LINE	-----
SECTION LINE	-----
EXISTING ROAD OR TRAVELED WAY	-----
PROPOSED ROAD OR TRAVELED WAY	-----
RAILROAD	-----
SURVEY LINE	-----
BRIDGES	-----

EQUATIONS

STA. 149 + 82.018 AH =
STA. 149 + 93.505 BK

LENGTH DATA

LENGTH OF ROADWAY	6,900	FT.	1.31	MI.
LENGTH OF BRIDGES	670	FT.	0.13	MI.
LENGTH OF PROJECT (NET)	7,570	FT.	1.44	MI.
LENGTH OF EXCEPTIONS				
LENGTH OF PROJECT (GROSS)	7,570	FT.	1.44	MI.

EXCEPTIONS

NONE

DESIGN CONTROL

55 MPH = V (SPEED DESIGN)

ADT (2030) = 1800; ADT (2040) = 2000

DHV = 240 ; D = 60 % T = 8 %

PERMITS ACQUIRED BY MDOT

WETLANDS AND WATERS PERMITS		
	WATERS	WETLANDS
NATIONWIDE #14	<input type="checkbox"/>	<input type="checkbox"/>
NATIONWIDE (OTHER)*	<input type="checkbox"/>	<input type="checkbox"/>
GENERAL*	<input type="checkbox"/>	<input type="checkbox"/>
INDIVIDUAL (404)*	<input type="checkbox"/>	<input type="checkbox"/>
STORMWATER PERMIT <input type="checkbox"/>		
Y	REQUIRED, (NOI SUBMITTED BY MDOT (DISTURBED AREA = 5 ACRES))	
S	REQUIRED, (NOI TO BE SUBMITTED BY CONTRACTOR (1 TO 4.99 ACRES))	
N	NO STORMWATER PERMIT REQUIRED (<1 ACRE)	
APPROVED BY: _____		

P S & E DATE:

APPROVED:
DEPUTY EXECUTIVE DIRECTOR / CHIEF ENGINEER
EXECUTIVE DIRECTOR

PRELIMINARY
NOT FOR
CONSTRUCTION



7/31/2020 08:31:58 TITLE SHEET 310.DGN

DEMOLITION NOTES:
 REMOVE EX. ASPHALT FROM STA. 93+00 TO 97+00 FROM STA. 103+00 TO 115+00
 REMOVE EX. ASPHALT AND ROAD EMBANKMENT FROM STA. 97+00 TO 103+00

SUPER EL. RC FT/FT WIDTH
 EXTRA WIDTH ON INSIDE 0 FT
 SEE DWG. SE-2A CASE I

Phase 1		
EARTHWORK TOTAL THIS SHEET		
Cut	41,322	CuYds
Fill	12,444	CuYds
Excess		CuYds
Surplus		CuYds
Borrow		CuYds

Phase 2		
EARTHWORK TOTAL THIS SHEET		
Cut	3,437	CuYds
Fill	116	CuYds
Excess		CuYds
Surplus		CuYds
Borrow		CuYds

Phase 3		
EARTHWORK TOTAL THIS SHEET		
Cut	0	CuYds
Fill	0	CuYds
Excess		CuYds
Surplus		CuYds
Borrow		CuYds

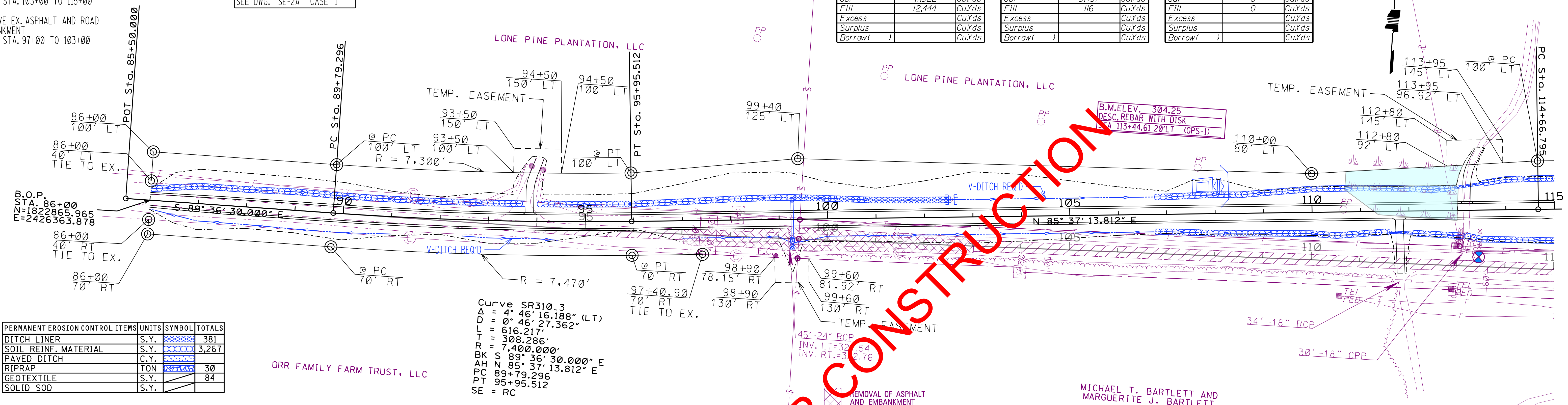

PERMANENT EROSION CONTROL ITEMS	UNITS	SYMBOL	TOTALS
DITCH LINER	S.Y.		381
SOIL REINF. MATERIAL	S.Y.		3,267
PAVED DITCH	C.Y.		
RIPRAP	TON		30
GEOTEXTILE	S.Y.		84
SOLID SOD	S.Y.		

Curve SR310-3
 Δ = 4° 46' 16.188" (LT)
 D = 0° 46' 27.362"
 L = 616.217'
 T = 308.286'
 BK = 7,400.000'
 S = 89° 36' 30.000" E
 AH = N 85° 37' 13.812" E
 PC = 89+79.296
 PT = 95+95.512
 SE = RC

WETLAND SITE	
TEMPORARILY FILLED	0.42 AC.
PERMANENTLY FILLED	0.32 AC.
BRIDGED	AC.

UTILITIES:
 TVEPA - (662) 563-4742
 ENTERGY - (800) 368-3749
 AT&T - (866) 484-5179

9/8/2020 3:17:12 PM WK3.DGN
 ROADWAY DESIGN DIVISION
 MISSISSIPPI DEPARTMENT OF TRANSPORTATION

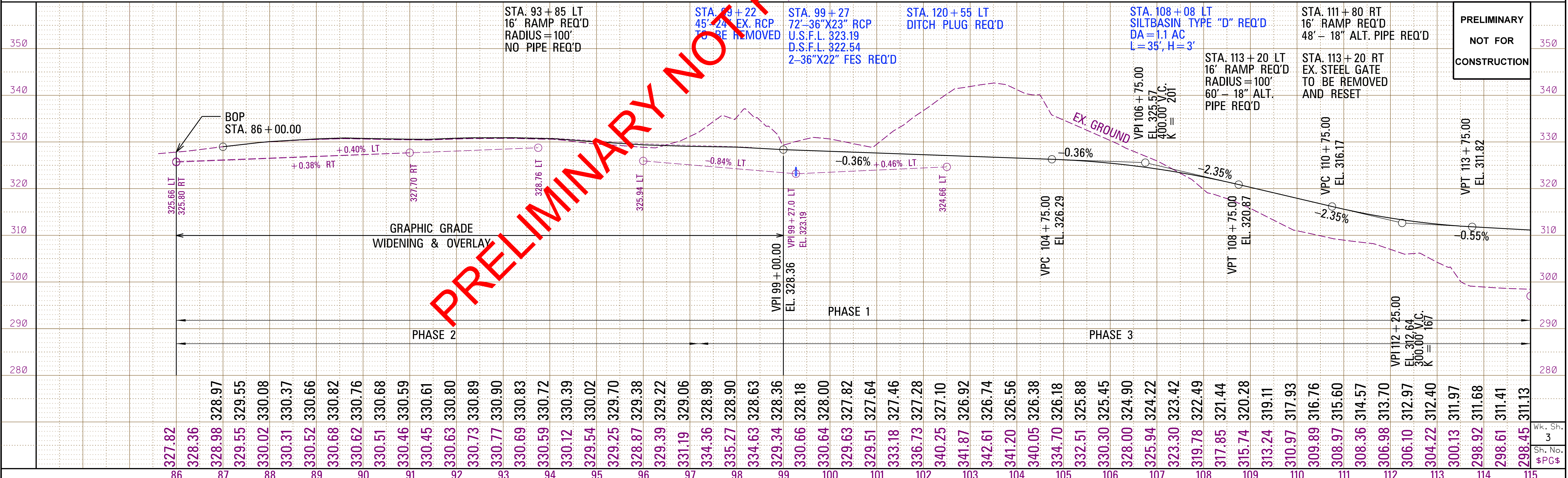

PRELIMINARY NOT FOR CONSTRUCTION

STATE	PROJECT NO.
MISS.	BR-0834-00(022)

DEMOLITION NOTES:
 REMOVE EX. ASPHALT
 FROM STA. 115+00 TO STA. 117+00
 FROM STA. 121+50 TO STA. 133+40
 FROM STA. 137+90 TO STA. 142+00
 FROM STA. 144+00 TO STA. 147+00

REMOVE EX. BRIDGE #33.2
 FROM STA. 118+80 TO STA. 120+36

REMOVE EX. BRIDGE #33.6
 FROM STA. 135+72 TO STA. 137+28

REMOVE EX. ASPHALT AND ROAD EMBANKMENT
 FROM STA. 117+00 TO 121+50 TO ELEV. 298.0' (MIN.)
 FROM STA. 133+40 TO 137+90 TO ELEV. 298.5' (MIN.)
 FROM STA. 142+00 TO STA. 144+00

Curve SR310-6
 $\Delta = 10^\circ 41' 15.372''$ (RT)
 $D = 0^\circ 29' 15.445''$
 $L = 2,191.773'$
 $T = 1,099.075'$
 $R = 11,750.000'$
 BK N $85^\circ 37' 13.812''$ E
 AH S $83^\circ 41' 30.816''$ E
 PT 114+66.795
 PT 136+58.568
 SE = NC

SUPER EL. NC FT/FT WIDTH
 EXTRA WIDTH ON INSIDE 0 FT
 SEE DWG. SE-2A CASE I

SUPER EL. 2.4% FT/FT WIDTH
 EXTRA WIDTH ON INSIDE 0 FT
 SEE DWG. SE-2A CASE I

Curve SR310-9
 $\Delta = 6^\circ 40' 39.237''$ (LT)
 $D = 0^\circ 56' 21.390''$
 $L = 710.928'$
 $T = 355.867'$
 $R = 6,100.000'$
 BK S $83^\circ 41' 30.816''$ E
 AH N $89^\circ 37' 49.947''$ E
 PT 142+82.578
 PT 149+93.505
 SE = 2.40%

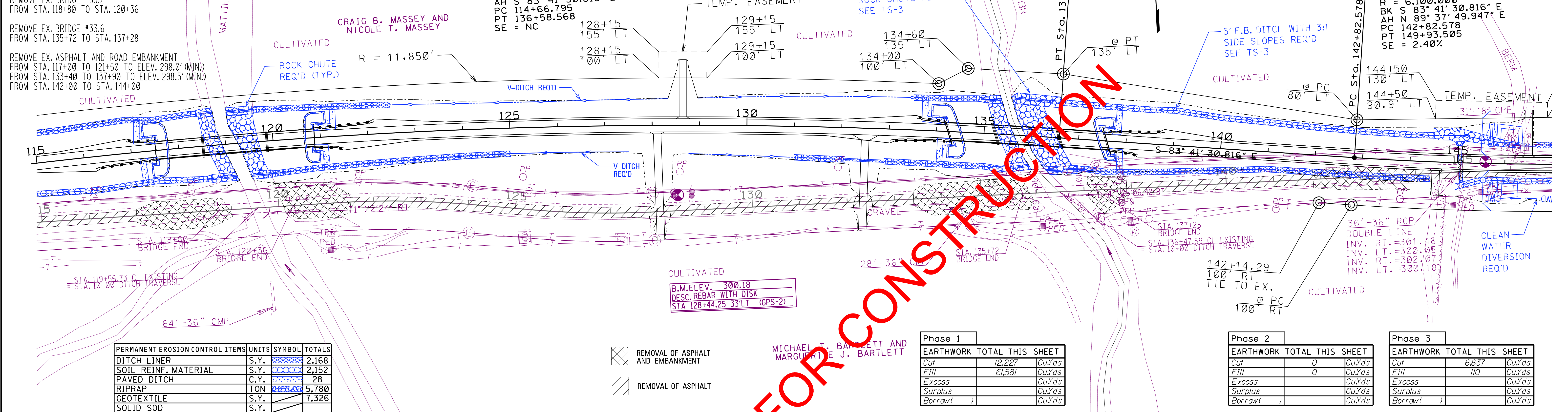

PERMANENT EROSION CONTROL ITEMS	UNITS	SYMBOL	TOTALS
DITCH LINER	S.Y.	[Symbol]	2,168
SOIL REINF. MATERIAL	S.Y.	[Symbol]	2,152
PAVED DITCH	C.Y.	[Symbol]	28
RIPRAP	TON	[Symbol]	5,780
GEOTEXTILE	S.Y.	[Symbol]	7,326
SOLID SOD	S.Y.	[Symbol]	

- [Symbol] REMOVAL OF ASPHALT AND EMBANKMENT
- [Symbol] REMOVAL OF ASPHALT

Phase 1

EARTHWORK TOTAL THIS SHEET	
Cut	12,227 CuYds
Fill	61,581 CuYds
Excess	CuYds
Surplus	CuYds
Borrow	CuYds

Phase 2

EARTHWORK TOTAL THIS SHEET	
Cut	0 CuYds
Fill	0 CuYds
Excess	CuYds
Surplus	CuYds
Borrow	CuYds

Phase 3

EARTHWORK TOTAL THIS SHEET	
Cut	6,637 CuYds
Fill	110 CuYds
Excess	CuYds
Surplus	CuYds
Borrow	CuYds

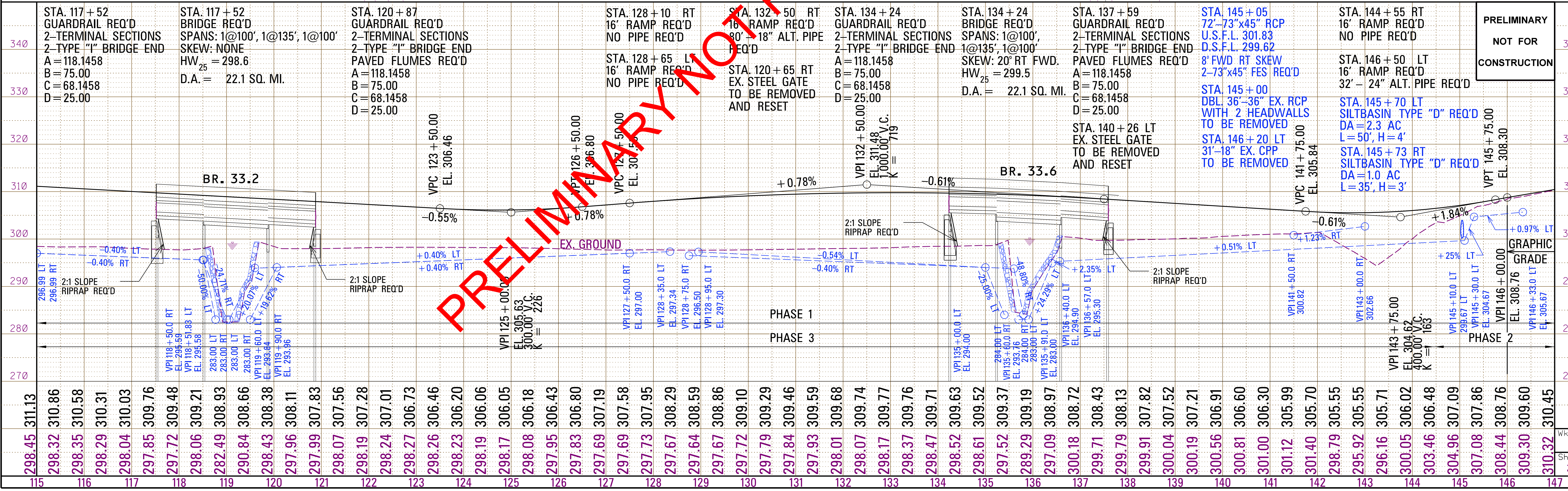

Station	Elevation	Notes
115	298.45	311.13
116	298.32	310.86
117	298.35	310.58
118	298.29	310.31
119	298.04	310.03
120	297.85	309.76
121	297.72	309.48
122	298.06	309.21
123	282.49	308.93
124	290.84	308.66
125	298.43	308.38
126	297.96	308.11
127	297.99	307.83
128	298.07	307.56
129	298.19	307.28
130	298.24	307.01
131	298.27	306.73
132	298.26	306.46
133	298.23	306.20
134	298.19	306.06
135	298.17	306.05
136	298.08	306.18
137	297.95	306.43
138	297.83	306.80
139	297.69	307.19
140	297.69	307.58
141	297.73	307.95
142	297.67	308.29
143	297.64	308.59
144	297.67	308.86
145	297.72	309.10
146	297.79	309.29
147	297.84	309.46
148	297.93	309.59
149	298.01	309.68
150	298.07	309.74
151	298.17	309.77
152	298.37	309.76
153	298.47	309.71
154	298.52	309.63
155	298.61	309.52
156	297.52	309.37
157	289.29	309.19
158	297.09	308.97
159	300.18	308.72
160	299.71	308.43
161	299.79	308.13
162	299.91	307.82
163	300.04	307.52
164	300.19	307.21
165	300.56	306.91
166	300.81	306.60
167	301.00	306.30
168	301.12	305.99
169	301.40	305.70
170	298.79	305.55
171	295.92	305.55
172	296.16	305.71
173	300.05	306.02
174	303.46	306.48
175	304.96	307.09
176	307.08	307.86
177	308.44	308.76
178	309.30	309.60
179	310.32	310.45

PRELIMINARY
 NOT FOR
 CONSTRUCTION

STATE	PROJECT NO.
MISS.	BR-0834-00(022)

B.M. ELEV. 306.62
DESC. REBAR WITH DISK
STA 145+48.35 20' LT (GPS-3)

PERMANENT EROSION CONTROL ITEMS	UNITS	SYMBOL	TOTALS
DITCH LINER	S.Y.		779
SOIL REINF. MATERIAL	S.Y.		523
PAVED DITCH	C.Y.		
RIPRAP	TON		
GEOTEXTILE	S.Y.		
SOLID SOD	S.Y.		

Phase 1		
EARTHWORK TOTAL THIS SHEET		
Cut	1,610	Cu.Yds
Fill	41	Cu.Yds
Excess		Cu.Yds
Surplus		Cu.Yds
Borrow()		Cu.Yds

Phase 2		
EARTHWORK TOTAL THIS SHEET		
Cut	7,861	Cu.Yds
Fill	406	Cu.Yds
Excess		Cu.Yds
Surplus		Cu.Yds
Borrow()		Cu.Yds

Phase 3		
EARTHWORK TOTAL THIS SHEET		
Cut	0	Cu.Yds
Fill	0	Cu.Yds
Excess		Cu.Yds
Surplus		Cu.Yds
Borrow()		Cu.Yds

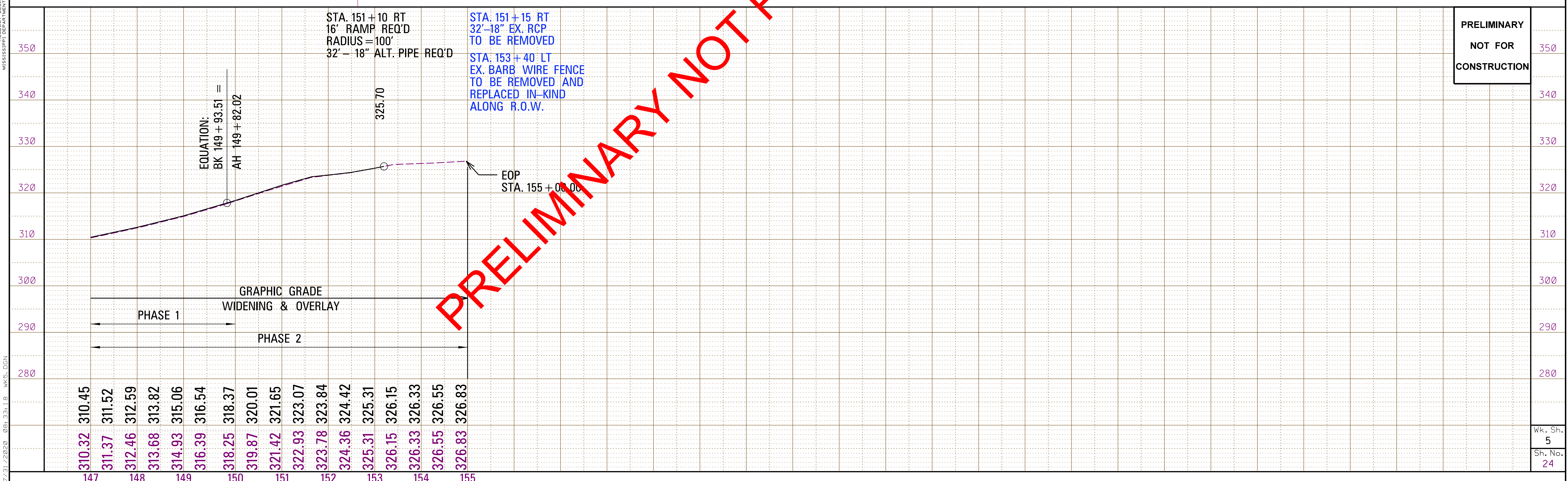
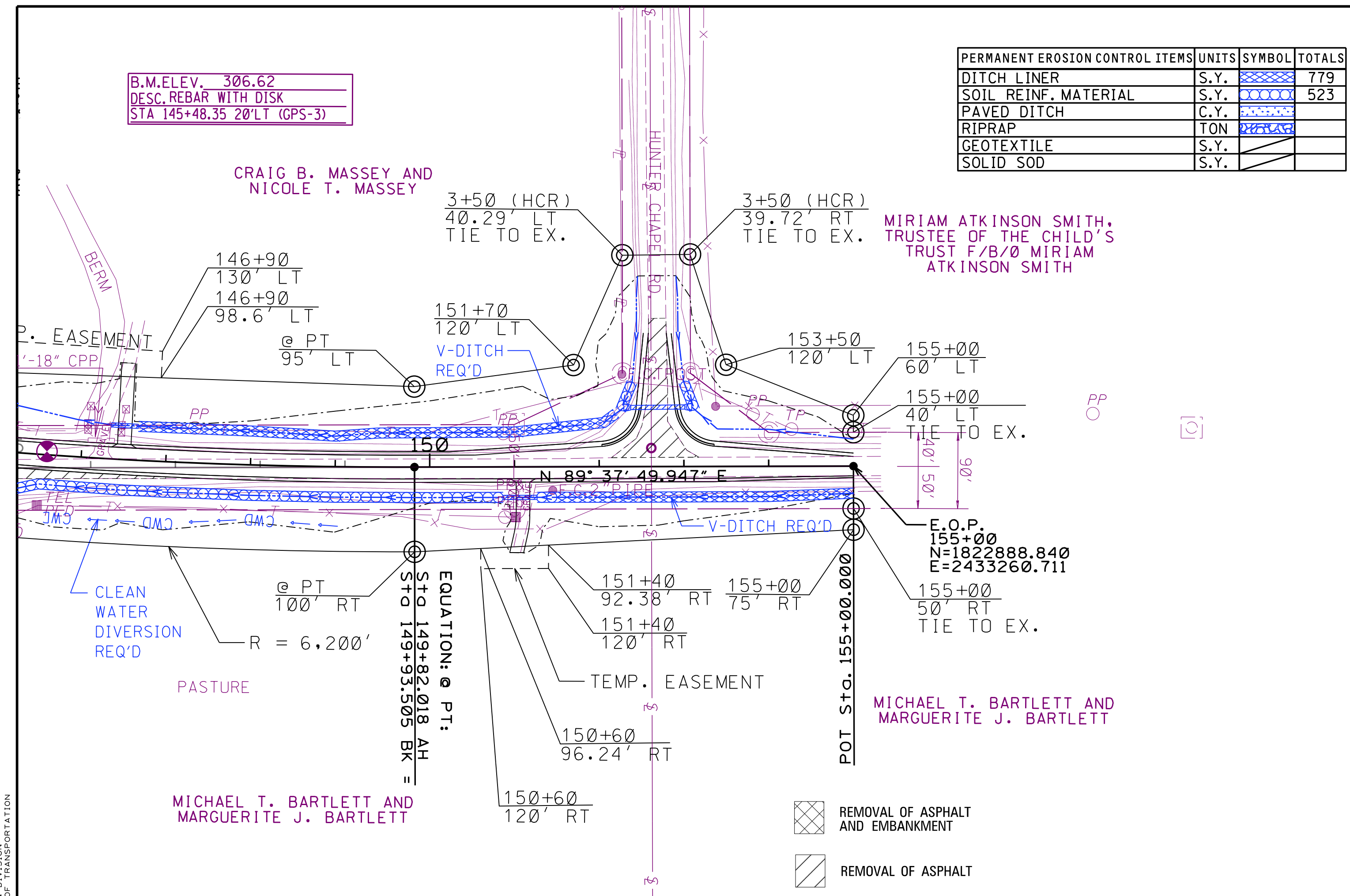

PRELIMINARY NOT FOR CONSTRUCTION

L. L. MASSEY ROADWAY DESIGN DIVISION MISSISSIPPI DEPARTMENT OF TRANSPORTATION

7/31/2020 08:33:18 WK5.DGN

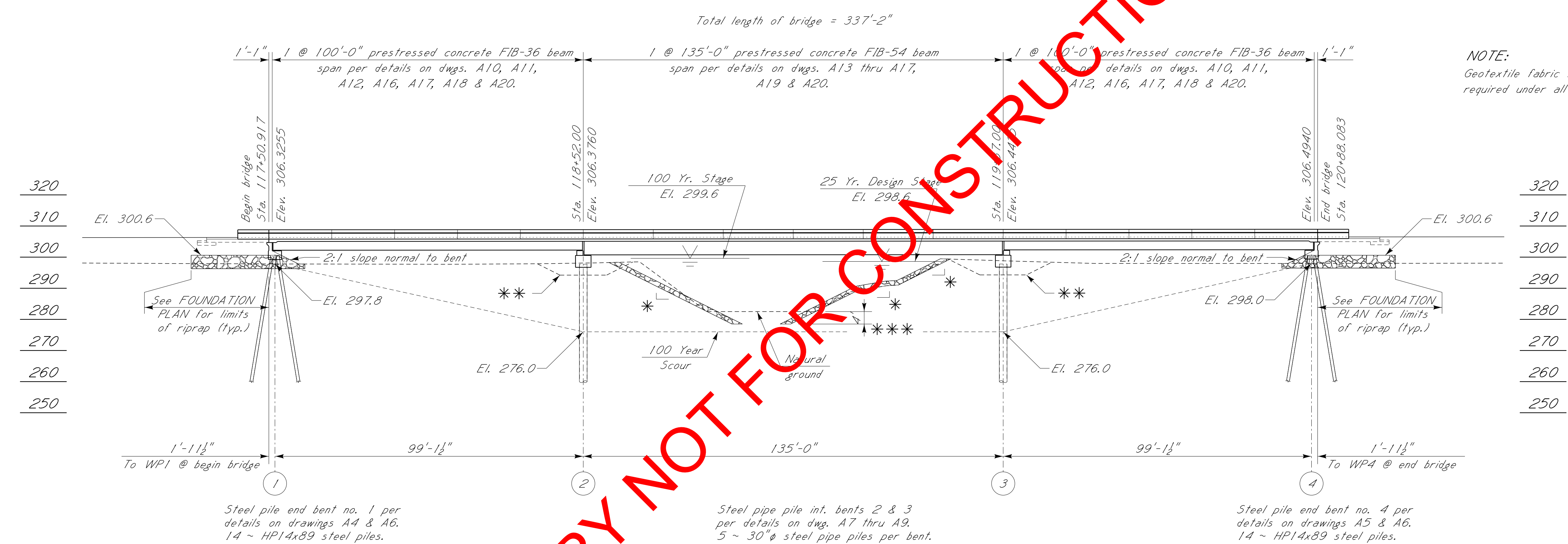
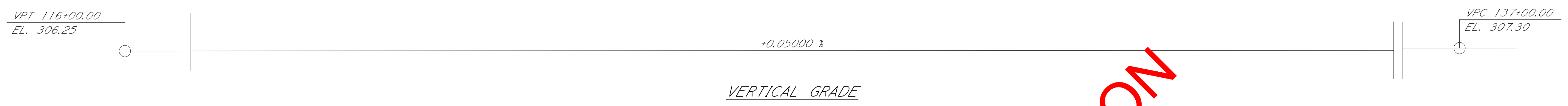

NOTE:
Geotextile fabric is required under all riprap.

*** NOTE:**
Reshape channel banks on a maximum 2:1 slope

**** NOTE:**
Interior bent caps are to be formed. Excavate as necessary to form caps. Restore excavation to original natural ground after removal of forms.

***** NOTE:**
4' toe down slope termination. See RIPRAP CHANNEL DETAIL on dwg. no. A1 for more details.

NOTE:
Horizontal dimensions are measured along & SR 310 arc.

500 YR. SCOUR ELEVATIONS	
Bent No.	Elevation Feet
1	297.8
2	274.9
3	274.9
4	298.0

DRAINAGE DATA FOR BRIDGE #33.2 AND #33.6 COMMON FLOODPLAIN:
 Drainage Area 22.1 Sq. Miles
 Total Q25 (U.S.G.S.) 10,100 CFS
 Total Q100 (U.S.G.S.) 13,100 CFS

DRAINAGE DATA FOR BRIDGE #33.2 ACROSS MATTIE CREEK:
 Q25 5,572 CFS
 Q100 7,199 CFS
 Effective Area Provided 1,134 SF
 Velocity 5.01 FPS

PRELIMINARY
NOT FOR
CONSTRUCTION



OFFICE REVIEW	
MISSISSIPPI DEPARTMENT OF TRANSPORTATION BRIDGE AT STA. 117+50.917 SR 310 ACROSS MATTIE CREEK - BR. 33.2	
ELEVATION	
PROJECT	BR-0834-00(022) 106967/301000
PANOLA COUNTY	WORKING NUMBER A2 OF 21
DESIGNER M. Wesley Phillips, P.E. DETAILER M. Wesley Phillips, P.E.	CHECKER B. Keith Carr, P.E. ISSUE DATE
DATE	SHEET NUMBER 8004
DIRECTOR OF STRUCTURES, STATE BRIDGE ENGINEER - JUSTIN WALKER PE. DEP. DIRECTOR OF STRUCTURES, ASSIST. STATE BRIDGE ENGINEER - SCOTT WESTERFIELD PE.	

Curve SR310_6
 $\Delta = 10^\circ 41' 15.372''$ (RT)
 $D = 0^\circ 29' 15.445''$
 $L = 2,191.773'$
 $T = 1,099.075'$
 $R = 11,750.000'$
 $BK N 85^\circ 37' 13.812'' E$
 $AH S 83^\circ 41' 30.816'' E$
 $PC Sta. 114+66.795$
 $PT Sta. 136+58.568$
 $SE = NC$

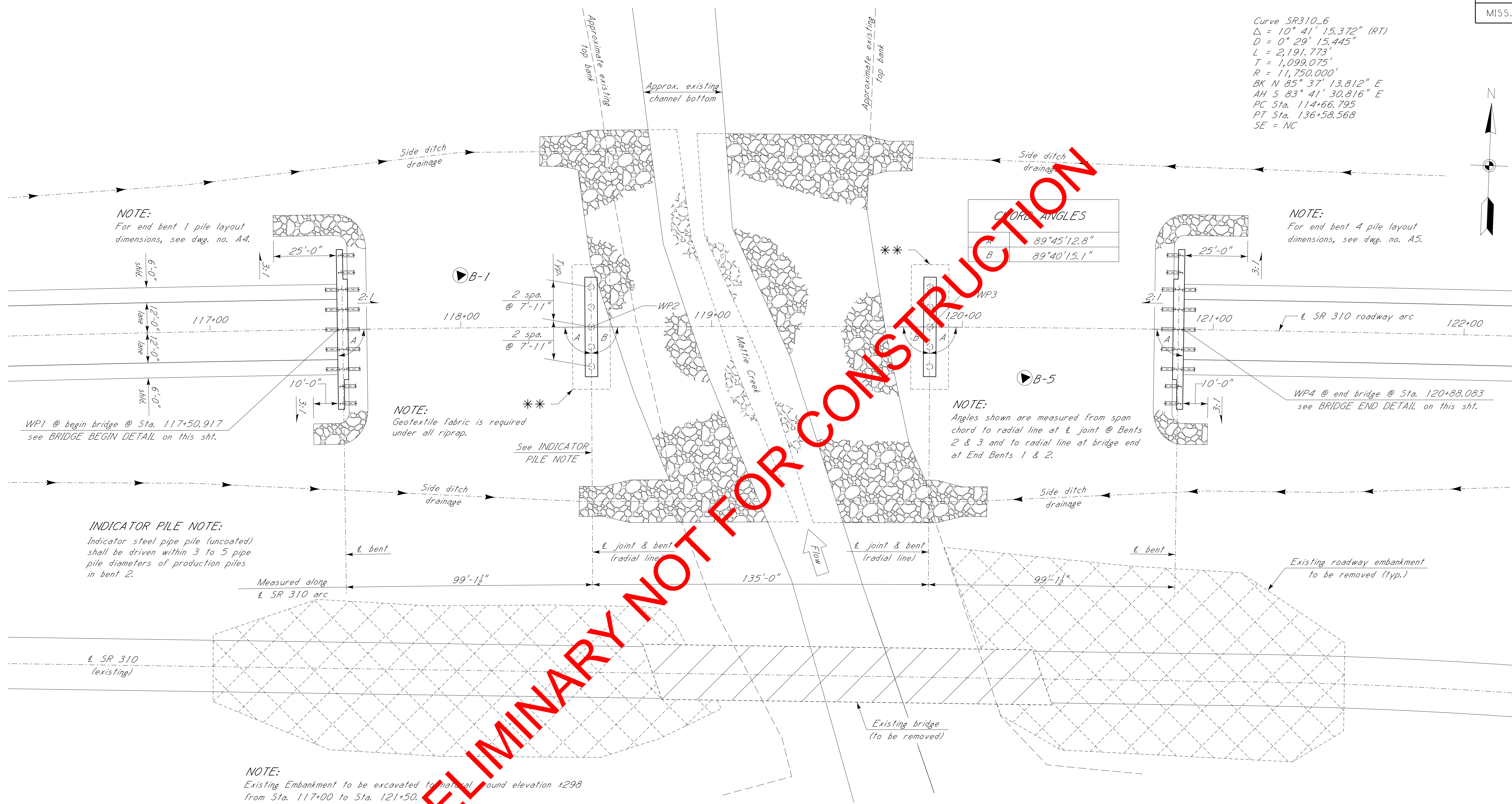
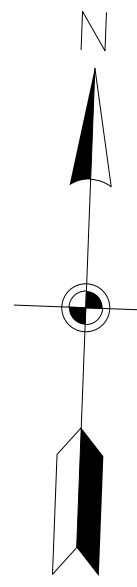

PRELIMINARY NOT FOR CONSTRUCTION

FOUNDATION PLAN
Scale: 1" = 20'-0"

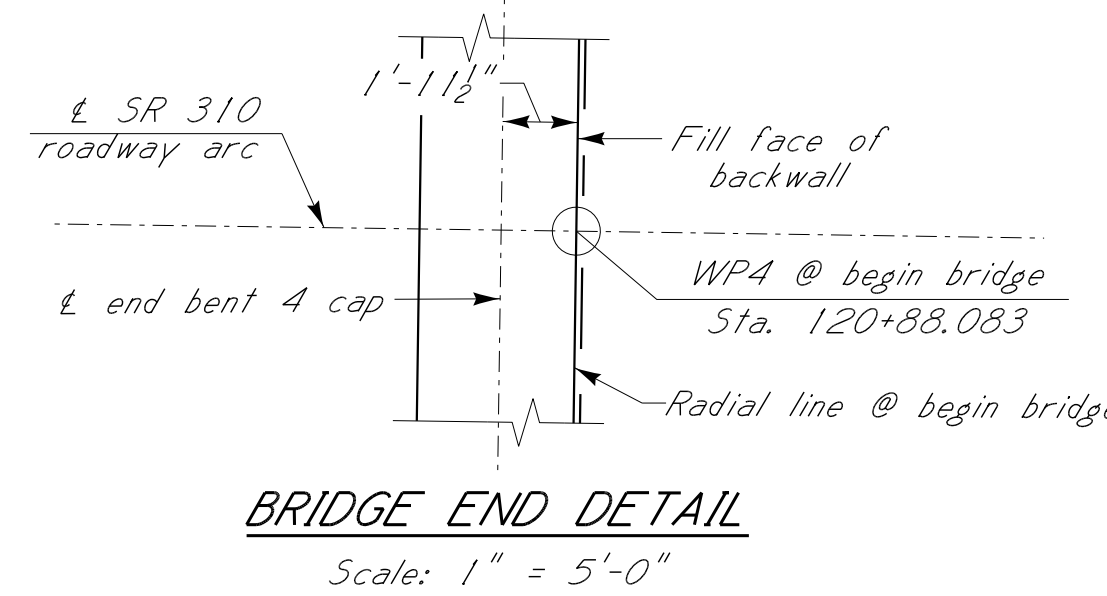
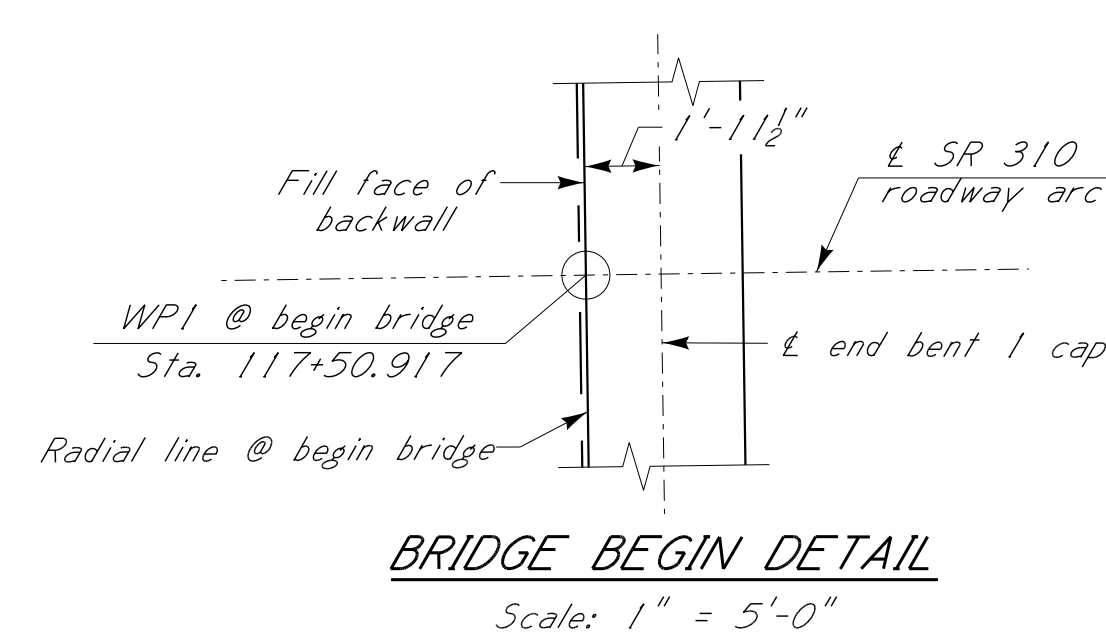

**** NOTE:**
Interior bent caps are to be framed. Excavate as necessary to form caps. Restore excavation to original natural ground after removal of forms.

PRELIMINARY NOT FOR CONSTRUCTION



DATE: _____

OFFICE REVIEW

BY		MISSISSIPPI DEPARTMENT OF TRANSPORTATION	
BR		BRIDGE AT STA. 117+50.917	
SR		SR 310 ACROSS MATTIE CREEK - BR. 33.2	
FOUNDATION PLAN		PROJECT	
BR-0834-00(022)		BR-0834-00(022)	
106967/301000		106967/301000	
PANOLA COUNTY		COUNTY	
A3 OF 21		WORKING NUMBER	
8005		SHEET NUMBER	
DESIGNER	M. Wesley Phillips, P.E.	CHECKER	B. Keith Carr, P.E.
DATE	_____	ISSUE DATE	_____
DIRECTOR OF STRUCTURES, STATE BRIDGE ENGINEER - JUSTIN WALKER PE.		DEP. DIRECTOR OF STRUCTURES, ASSIST. STATE BRIDGE ENGINEER - SCOTT WESTERFIELD PE.	

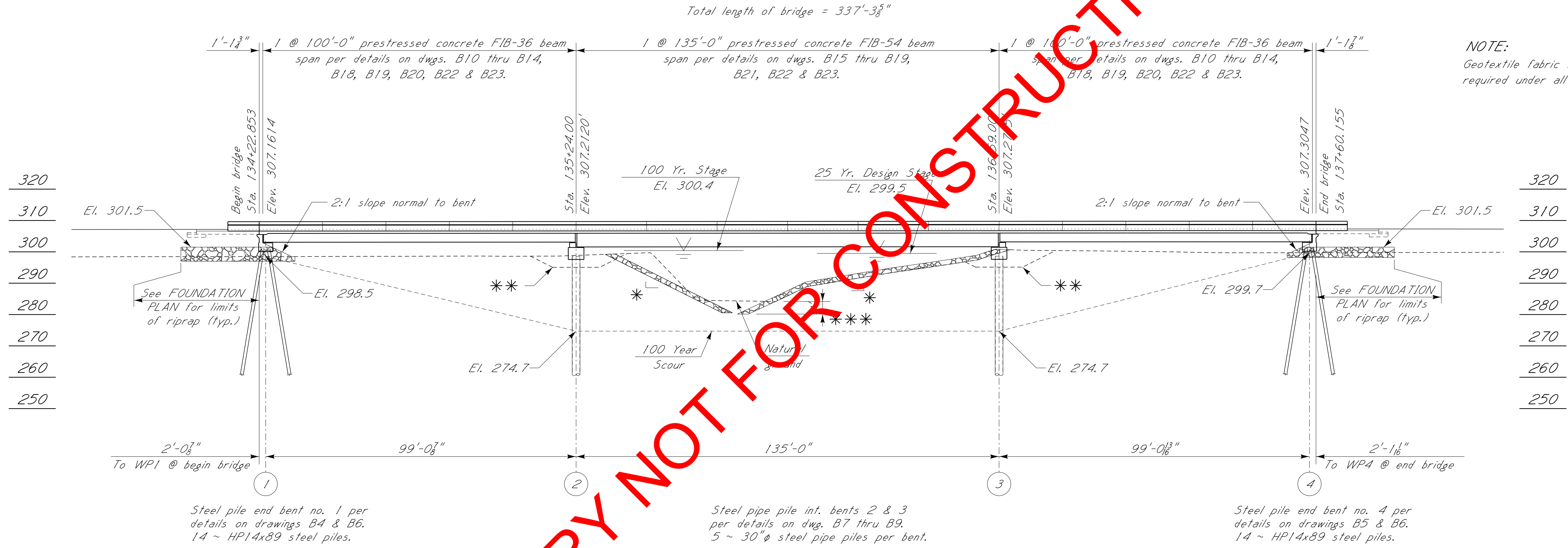
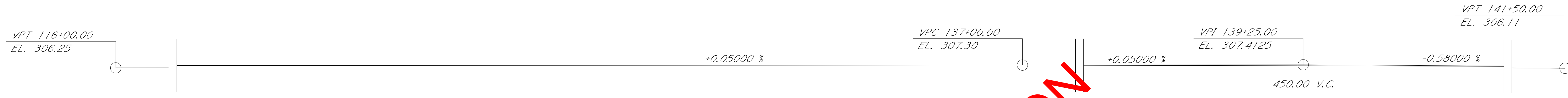

NOTE:
Geotextile fabric is required under all riprap.

* NOTE:
Reshape channel banks on a maximum 2:1 slope

** NOTE:
Interior bent caps are to be formed. Excavate as necessary to form caps. Restore excavation to original natural ground after removal of forms.

*** NOTE:
4' toe down slope termination. See RIPRAP CHANNEL DETAIL on dwg. no. B1 for more details.

NOTE:
Horizontal dimensions are measured along & SR 310 arc or tangent.

500 YR. SCOUR ELEVATIONS	
Bent No.	Elevation Feet
1	298.5
2	273.6
3	273.6
4	299.7

ELEVATION WITH PROFILE ALONG & SR 310 ROADWAY ARC/TANGENT
Scale: 1" = 20'-0"

DRAINAGE DATA FOR BRIDGE *33.2 AND *33.6 COMMON FLOODPLAIN:
 Drainage Area 22.1 Sq. Miles
 Total Q25 (U.S.G.S.) 10,100 CFS
 Total Q100 (U.S.G.S.) 13,100 CFS

DRAINAGE DATA FOR BRIDGE *33.6 ACROSS NELSON CREEK:
 Q25 4,528 CFS
 Q100 5,901 CFS
 Effective Area Provided 966 SF
 Velocity 4.69 FPS

PRELIMINARY NOT FOR CONSTRUCTION

PRELIMINARY NOT FOR CONSTRUCTION
DATE: _____



OFFICE REVIEW	
MISSISSIPPI DEPARTMENT OF TRANSPORTATION BRIDGE AT STA. 134+22.853 SR 310 ACROSS NELSON CREEK - BR. 33.6 ELEVATION	
PROJECT	BR-0834-00(022) 106967/301000
PANOLA COUNTY	WORKING NUMBER B2 OF 24
DESIGNER M. Wesley Phillips, P.E. DETAILER M. Wesley Phillips, P.E.	CHECKER B. Keith Carr, P.E. ISSUE DATE _____
DATE _____	SHEET NUMBER 8025
DIRECTOR OF STRUCTURES, STATE BRIDGE ENGINEER - JUSTIN WALKER PE. DEP. DIRECTOR OF STRUCTURES, ASSIST. STATE BRIDGE ENGINEER - SCOTT WESTERFIELD PE.	

Curve SR310_6
 $\Delta = 10^\circ 41' 15.372''$ (RT)
 $D = 0^\circ 29' 15.445''$
 $L = 2,191.773'$
 $T = 1,099.075'$
 $R = 11,750.000'$
 $BK N 85^\circ 37' 13.812'' E$
 $AH S 83^\circ 41' 30.816'' E$
 $PC Sta. 114+66.795$
 $PT Sta. 136+58.568$
 $SE = NC$

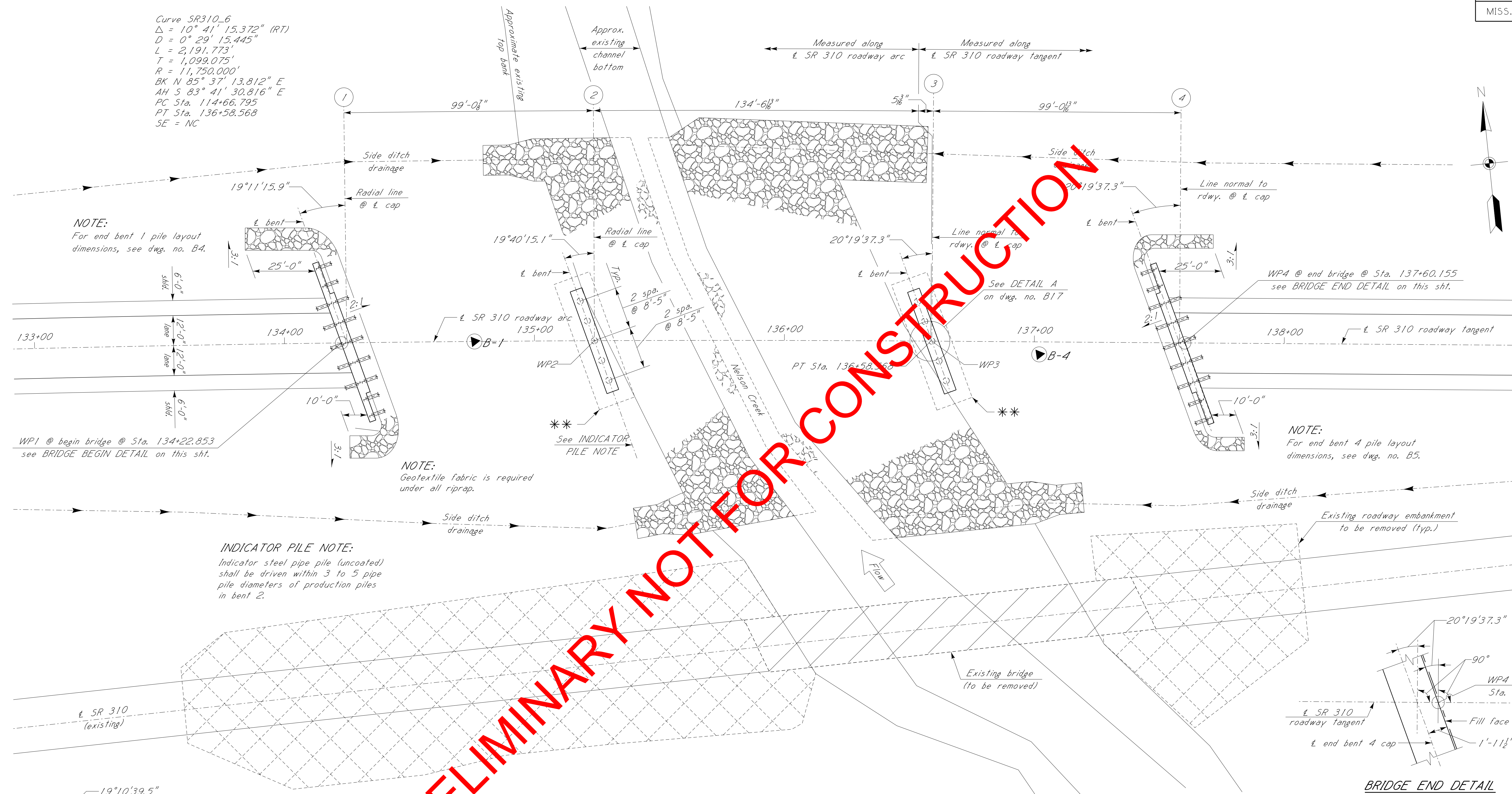

NOTE:
 For end bent 1 pile layout dimensions, see dwg. no. B4.

NOTE:
 For end bent 4 pile layout dimensions, see dwg. no. B5.

NOTE:
 Geotextile fabric is required under all riprap.

INDICATOR PILE NOTE:
 Indicator steel pipe pile (uncoated) shall be driven within 3 to 5 pipe pile diameters of production piles in bent 2.

NOTE:
 Existing Embankment to be excavated to natural ground elevation ± 298.5 from Sta. 133+40 to Sta. 137+90.

**** NOTE:**
 Interior bent caps are to be formed. Excavate as necessary to form caps. Restore excavation to original natural ground after removal of forms.

PRELIMINARY NOT FOR CONSTRUCTION

FOUNDATION PLAN
 Scale: 1" = 20'-0"

BRIDGE END DETAIL
 Scale: 1" = 5'-0"

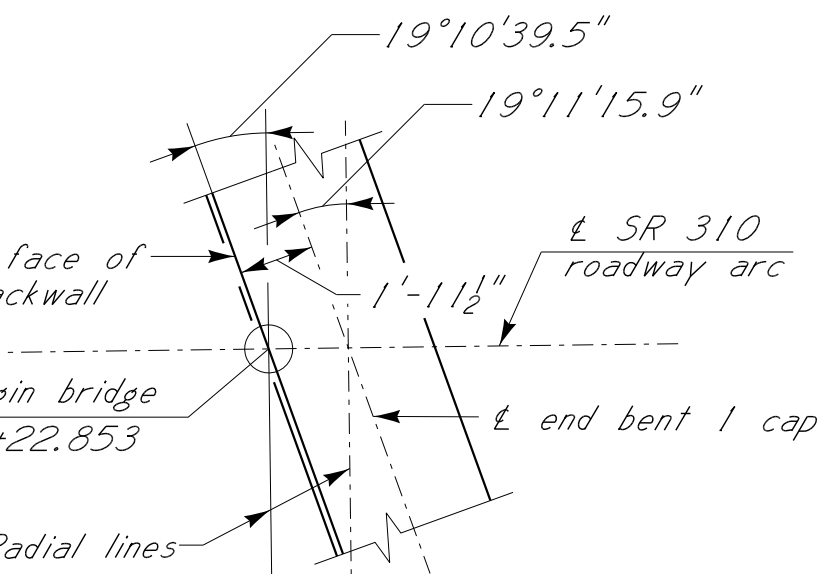

BRIDGE BEGIN DETAIL
 Scale: 1" = 5'-0"

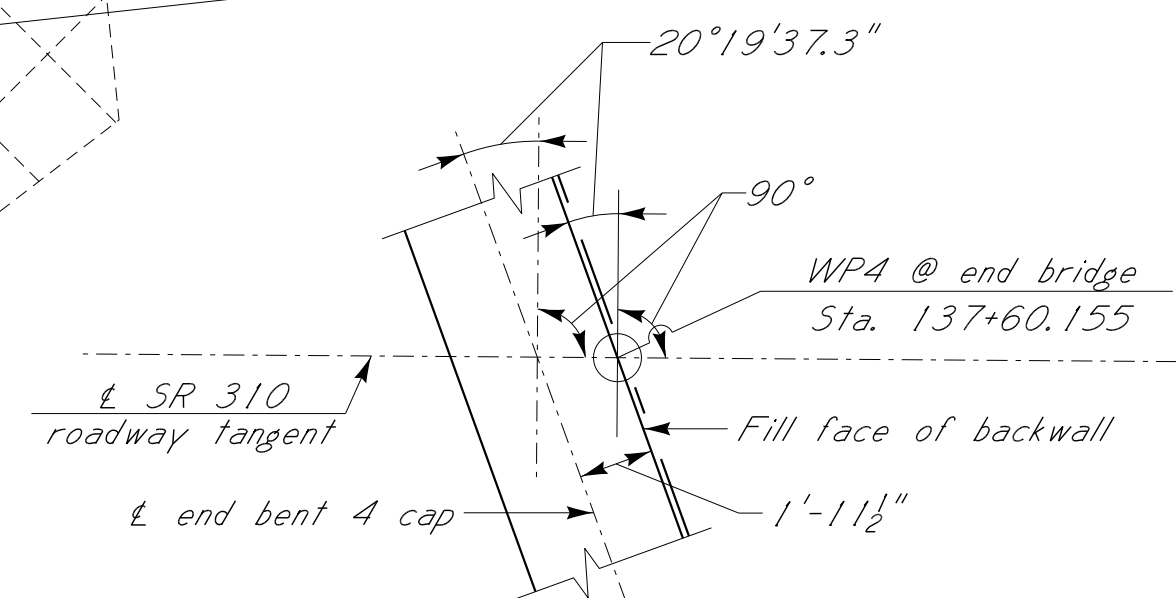

BRIDGE END DETAIL
 Scale: 1" = 5'-0"

FILE: NS-JACKSONS 06-51ru Projects 14089.011 - Panola County Bridges Drawings Bridge B - Nelson Creek 14089011-B3-FOUNDATION Plan.dgn
 DATE: 7/31/2020 TIME: 3:14:22 PM USER: MWP

PRELIMINARY
 NOT FOR
 CONSTRUCTION



DATE: _____

REVISIONS		BY	

MISSISSIPPI DEPARTMENT OF TRANSPORTATION
 BRIDGE AT STA. 134+22.853
 SR 310 ACROSS NELSON CREEK - BR. 33.6
FOUNDATION PLAN
 PROJECT BR-0834-00(022)
 106967/301000
 PANOLA COUNTY
 WORKING NUMBER B3 OF 24
 SHEET NUMBER 8026
 DESIGNER M. Wesley Phillips, P.E. CHECKER B. Keith Carr, P.E.
 DETAILER Kevin J. Kennedy, P.E. ISSUE DATE _____
 DIRECTOR OF STRUCTURES, STATE BRIDGE ENGINEER - JUSTIN WALKER, P.E.
 DEP. DIRECTOR OF STRUCTURES, ASSIST. STATE BRIDGE ENGINEER - SCOTT WESTERFIELD, P.E.

404 Permit Conditions &
401 Water Quality Certification

**CERTIFICATION OF COMPLIANCE
WITH DEPARTMENT OF THE ARMY PERMIT**

Nationwide Permit NWP 23
Number: Identification MVK-2021-785
Number: Name of MDOT
Permittee: Issued Date: 09/08/2021
Evaluator Name: Mr. Anthony
Expiration Date: Lobred 3/18/2022

Upon completion of the activity authorized by this permit, sign this certification and return it to the following address:

USACE, Vicksburg District
ATTN: Regulatory Division
4155 Clay Street
Vicksburg, Mississippi 39183-3435

Please note that your permitted activity is subject to a compliance inspection by an Army Corps of Engineers representative. If you fail to comply with this permit, you are subject to permit modification, suspension, or revocation.

I hereby certify that the work authorized by the above-referenced permit has been completed in accordance with the terms and conditions of the said permit including any required mitigation.

Date Work was Completed: _____

Signature of Permittee

Date Signed

SPECIAL CONDITIONS
NATIONWIDE PERMIT No. 23

Approved Categorical Exclusions

Activities undertaken, assisted, authorized, regulated, funded, or financed, in whole or in part, by another Federal agency or department where:

(a) That agency or department has determined, pursuant to the Council on Environmental Quality's implementing regulations for the National Environmental Policy Act (40 CFR part 1500 et seq.), that the activity is categorically excluded from the requirement to prepare an environmental impact statement or environmental assessment analysis, because it is included within a category of actions which neither individually nor cumulatively have a significant effect on the human environment; and

(b) The Office of the Chief of Engineers (Attn: CECW-CO) has concurred with that agency's or department's determination that the activity is categorically excluded and approved the activity for authorization under NWP 23.

The Office of the Chief of Engineers may require additional conditions, including pre-construction notification, for authorization of an agency's categorical exclusions under this NWP.

Notification: Certain categorical exclusions approved for authorization under this NWP require the permittee to submit a pre-construction notification to the district engineer prior to commencing the activity (see general condition 32). The activities that require pre-construction notification are listed in the appropriate Regulatory Guidance Letters. (Authorities: Sections 10 and 404)

Note: The agency or department may submit an application for an activity believed to be categorically excluded to the Office of the Chief of Engineers (Attn: CECW-CO). Prior to approval for authorization under this NWP of any agency's activity, the Office of the Chief of Engineers will solicit public comment. As of the date of issuance of this NWP, agencies with approved categorical exclusions are: the Bureau of Reclamation, Federal Highway Administration, and U.S. Coast Guard. Activities approved for authorization under this NWP as of the date of this notice are found in Corps Regulatory Guidance Letter 05-07, which is available at:

<http://www.usace.army.mil/Portals/2/docs/civilworks/RGLS/rgl05-07.pdf> . Any future approved categorical exclusions will be announced in Regulatory Guidance Letters and posted on this same web site.

2017 Nationwide Permits General Conditions, Further Information, and Definitions

A. Nationwide Permit General Conditions

Note: To qualify for NWP authorization, the prospective permittee must comply with the following general conditions, as applicable, in addition to any regional or case-specific conditions imposed by the division engineer or district engineer. Prospective permittees should contact the appropriate Corps district office to determine if regional conditions have been imposed on an NWP. Prospective permittees should also contact the appropriate Corps district office to determine the status of Clean Water Act Section 401 water quality certification and/or Coastal Zone Management Act consistency for an NWP. Every person who may wish to obtain permit authorization under one or more NWPs, or who is currently relying on an existing or prior permit authorization under one or more NWPs, has been and is on notice that all of the provisions of 33 CFR 330.1 through 330.6 apply to every NWP authorization. Note especially 33 CFR 330.5 relating to the modification, suspension, or revocation of any NWP authorization.

1. Navigation. (a) No activity may cause more than a minimal adverse effect on navigation.

(b) Any safety lights and signals prescribed by the U.S. Coast Guard, through regulations or otherwise, must be installed and maintained at the permittee's expense on authorized facilities in navigable waters of the United States.

(c) The permittee understands and agrees that, if future operations by the United States require the removal, relocation, or other alteration, of the structure or work herein authorized, or if, in the opinion of the Secretary of the Army or his authorized representative, said structure or work shall cause unreasonable obstruction to the free navigation of the navigable waters, the permittee will be required, upon due notice from the Corps of Engineers, to remove, relocate, or alter the structural work or obstructions caused thereby, without expense to the United States. No claim shall be made against the United States on account of any such removal or alteration.

2. Aquatic Life Movements. No activity may substantially disrupt the necessary life cycle movements of those species of aquatic life indigenous to the waterbody, including those species that normally migrate through the area, unless the activity's primary purpose is to impound water. All permanent and temporary crossings of waterbodies shall be suitably culverted, bridged, or otherwise designed and constructed to maintain low flows to sustain the movement of those aquatic species. If a bottomless culvert cannot be used, then the crossing should be designed and constructed to minimize adverse effects to aquatic life movements.

3. Spawning Areas. Activities in spawning areas during spawning seasons must be avoided to the maximum extent practicable. Activities that result in the physical destruction (e.g., through excavation, fill, or downstream smothering by substantial turbidity) of an important spawning area are not authorized.

4. Migratory Bird Breeding Areas. Activities in waters of the United States that serve as breeding areas for migratory birds must be avoided to the maximum extent practicable.

5. Shellfish Beds. No activity may occur in areas of concentrated shellfish populations, unless the activity is directly related to a shellfish harvesting activity authorized by NWPs 4 and 48, or is a shellfish seeding or habitat restoration activity authorized by NWP 27.

6. Suitable Material. No activity may use unsuitable material (e.g., trash, debris, car bodies, asphalt, etc.). Material used for construction or discharged must be free from toxic pollutants in toxic amounts (see section 307 of the Clean Water Act).

7. Water Supply Intakes. No activity may occur in the proximity of a public water supply intake, except where the activity is for the repair or improvement of public water supply intake structures or adjacent bank stabilization.

8. Adverse Effects From Impoundments. If the activity creates an impoundment of water, adverse effects to the aquatic system due to accelerating the passage of water, and/or restricting its flow must be minimized to the maximum extent practicable.

9. Management of Water Flows. To the maximum extent practicable, the pre-construction course, condition, capacity, and location of open waters must be maintained for each activity, including stream channelization, storm water management activities, and temporary and permanent road crossings, except as provided below. The activity must be constructed to withstand expected high flows. The activity must not restrict or impede the passage of normal or high flows, unless the primary purpose of the activity is to impound water or manage high flows. The activity may alter the pre-construction course, condition, capacity, and location of open waters if it benefits the aquatic environment (e.g., stream restoration or relocation activities).

10. Fills Within 100-Year Floodplains. The activity must comply with applicable FEMA-approved state or local floodplain management requirements.

11. Equipment. Heavy equipment working in wetlands or mudflats must be placed on mats, or other measures must be taken to minimize soil disturbance.

12. Soil Erosion and Sediment Controls. Appropriate soil erosion and sediment controls must be used and maintained in effective operating condition during construction, and all exposed soil and other fills, as well as any work below the ordinary high water mark or high tide line, must be permanently stabilized at the earliest practicable date. Permittees are encouraged to perform work within waters of the United States during periods of low-flow or no-flow, or during low tides.

13. Removal of Temporary Fills. Temporary fills must be removed in their entirety and the affected areas returned to pre-construction elevations. The affected areas must be revegetated, as appropriate.

14. Proper Maintenance. Any authorized structure or fill shall be properly maintained, including maintenance to ensure public safety and compliance with applicable NWP general conditions, as well as any activity-specific conditions added by the district engineer to an NWP authorization.

15. Single and Complete Project. The activity must be a single and complete project. The same NWP cannot be used more than once for the same single and complete project.

16. Wild and Scenic Rivers. (a) No NWP activity may occur in a component of the National Wild and Scenic River System, or in a river officially designated by Congress as a "study river" for possible inclusion in the system while the river is in an official study status, unless the appropriate Federal agency with direct management responsibility for such river, has determined in writing that the proposed activity will not adversely affect the Wild and Scenic River designation or study status.

(b) If a proposed NWP activity will occur in a component of the National Wild and Scenic River System, or in a river officially designated by Congress as a "study river" for possible inclusion in the system while the river is in an official study status, the permittee must submit a pre-construction notification (see general condition 32). The district engineer will coordinate the PCN with the Federal agency with direct management responsibility for that river. The permittee shall not begin the NWP activity until notified by the district engineer that the Federal agency with direct management responsibility for that river has determined in writing that the proposed NWP activity will not adversely affect the Wild and Scenic River designation or study status.

(c) Information on Wild and Scenic Rivers may be obtained from the appropriate Federal land management agency responsible for the designated Wild and Scenic River or study river (e.g., National Park Service, U.S. Forest Service, Bureau of Land Management, U.S. Fish and Wildlife Service). Information on these rivers is also available at: <http://www.rivers.gov/>.

17. Tribal Rights. No NWP activity may cause more than minimal adverse effects on tribal rights (including treaty rights), protected tribal resources, or tribal lands.

18. Endangered Species. (a) No activity is authorized under any NWP which is likely to directly or indirectly jeopardize the continued existence of a threatened or endangered species or a species proposed for such designation, as identified under the Federal Endangered Species Act (ESA), or which will directly or indirectly destroy or adversely modify the critical habitat of such species. No activity is authorized under any NWP which "may affect" a listed species or critical habitat, unless ESA section 7 consultation addressing the effects of the proposed activity has been completed. Direct effects are the immediate effects on listed species and critical habitat caused by the

NWP activity. Indirect effects are those effects on listed species and critical habitat that are caused by the NWP activity and are later in time, but still are reasonably certain to occur.

(b) Federal agencies should follow their own procedures for complying with the requirements of the ESA. If pre-construction notification is required for the proposed activity, the Federal permittee must provide the district engineer with the appropriate documentation to demonstrate compliance with those requirements. The district engineer will verify that the appropriate documentation has been submitted. If the appropriate documentation has not been submitted, additional ESA section 7 consultation may be necessary for the activity and the respective federal agency would be responsible for fulfilling its obligation under section 7 of the ESA.

(c) Non-federal permittees must submit a pre-construction notification to the district engineer if any listed species or designated critical habitat might be affected or is in the vicinity of the activity, or if the activity is located in designated critical habitat, and shall not begin work on the activity until notified by the district engineer that the requirements of the ESA have been satisfied and that the activity is authorized. For activities that might affect Federally-listed endangered or threatened species or designated critical habitat, the pre-construction notification must include the name(s) of the endangered or threatened species that might be affected by the proposed activity or that utilize the designated critical habitat that might be affected by the proposed activity. The district engineer will determine whether the proposed activity "may affect" or will have "no effect" to listed species and designated critical habitat and will notify the non-Federal applicant of the Corps' determination within 45 days of receipt of a complete pre-construction notification. In cases where the non-Federal applicant has identified listed species or critical habitat that might be affected or is in the vicinity of the activity, and has so notified the Corps, the applicant shall not begin work until the Corps has provided notification that the proposed activity will have "no effect" on listed species or critical habitat, or until ESA section 7 consultation has been completed. If the non-Federal applicant has not heard back from the Corps within 45 days, the applicant must still wait for notification from the Corps.

(d) As a result of formal or informal consultation with the FWS or NMFS the district engineer may add species-specific permit conditions to the NWPs.

(e) Authorization of an activity by an NWP does not authorize the "take" of a threatened or endangered species as defined under the ESA. In the absence of separate authorization (e.g., an ESA Section 10 Permit, a Biological Opinion with "incidental take" provisions, etc.) from the FWS or the NMFS, the Endangered Species Act prohibits any person subject to the jurisdiction of the United States to take a listed species, where "take" means to harass, harm, pursue, hunt, shoot, wound, kill, trap, capture, or collect, or to attempt to engage in any such conduct. The word "harm" in the definition of "take" means an act which actually kills or injures wildlife. Such an act may include significant habitat modification or degradation where it actually kills or injures

wildlife by significantly impairing essential behavioral patterns, including breeding, feeding or sheltering.

(f) If the non-federal permittee has a valid ESA section 10(a)(1)(B) incidental take permit with an approved Habitat Conservation Plan for a project or a group of projects that includes the proposed NWP activity, the non-federal applicant should provide a copy of that ESA section 10(a)(1)(B) permit with the PCN required by paragraph (c) of this general condition. The district engineer will coordinate with the agency that issued the ESA section 10(a)(1)(B) permit to determine whether the proposed NWP activity and the associated incidental take were considered in the internal ESA section 7 consultation conducted for the ESA section 10(a)(1)(B) permit. If that coordination results in concurrence from the agency that the proposed NWP activity and the associated incidental take were considered in the internal ESA section 7 consultation for the ESA section 10(a)(1)(B) permit, the district engineer does not need to conduct a separate ESA section 7 consultation for the proposed NWP activity. The district engineer will notify the non-federal applicant within 45 days of receipt of a complete pre-construction notification whether the ESA section 10(a)(1)(B) permit covers the proposed NWP activity or whether additional ESA section 7 consultation is required.

(g) Information on the location of threatened and endangered species and their critical habitat can be obtained directly from the offices of the FWS and NMFS or their world wide web pages at <http://www.fws.gov/> or <http://www.fws.gov/ipac> and <http://www.nmfs.noaa.gov/pr/species/esa/> respectively.

19. Migratory Birds and Bald and Golden Eagles. The permittee is responsible for ensuring their action complies with the Migratory Bird Treaty Act and the Bald and Golden Eagle Protection Act. The permittee is responsible for contacting appropriate local office of the U.S. Fish and Wildlife Service to determine applicable measures to reduce impacts to migratory birds or eagles, including whether "incidental take" permits are necessary and available under the Migratory Bird Treaty Act or Bald and Golden Eagle Protection Act for a particular activity.

20. Historic Properties. (a) In cases where the district engineer determines that the activity may have the potential to cause effects to properties listed, or eligible for listing, in the National Register of Historic Places, the activity is not authorized, until the requirements of Section 106 of the National Historic Preservation Act (NHPA) have been satisfied.

(b) Federal permittees should follow their own procedures for complying with the requirements of section 106 of the National Historic Preservation Act. If pre-construction notification is required for the proposed NWP activity, the Federal permittee must provide the district engineer with the appropriate documentation to demonstrate compliance with those requirements. The district engineer will verify that the appropriate documentation has been submitted. If the appropriate documentation is not submitted, then additional consultation under section 106 may be necessary. The respective federal agency is responsible for fulfilling its obligation to comply with section 106.

(c) Non-federal permittees must submit a pre-construction notification to the district engineer if the NWP activity might have the potential to cause effects to any historic properties listed on, determined to be eligible for listing on, or potentially eligible for listing on the National Register of Historic Places, including previously unidentified properties. For such activities, the pre-construction notification must state which historic properties might have the potential to be affected by the proposed NWP activity or include a vicinity map indicating the location of the historic properties or the potential for the presence of historic properties. Assistance regarding information on the location of, or potential for, the presence of historic properties can be sought from the State Historic Preservation Officer, Tribal Historic Preservation Officer, or designated tribal representative, as appropriate, and the National Register of Historic Places (see 33 CFR 330.4(g)). When reviewing pre-construction notifications, district engineers will comply with the current procedures for addressing the requirements of section 106 of the National Historic Preservation Act. The district engineer shall make a reasonable and good faith effort to carry out appropriate identification efforts, which may include background research, consultation, oral history interviews, sample field investigation, and field survey. Based on the information submitted in the PCN and these identification efforts, the district engineer shall determine whether the proposed NWP activity has the potential to cause effects on the historic properties. Section 106 consultation is not required when the district engineer determines that the activity does not have the potential to cause effects on historic properties (see 36 CFR 800.3(a)). Section 106 consultation is required when the district engineer determines that the activity has the potential to cause effects on historic properties. The district engineer will conduct consultation with consulting parties identified under 36 CFR 800.2(c) when he or she makes any of the following effect determinations for the purposes of section 106 of the NHPA: no historic properties affected, no adverse effect, or adverse effect. Where the non-Federal applicant has identified historic properties on which the activity might have the potential to cause effects and so notified the Corps, the non-Federal applicant shall not begin the activity until notified by the district engineer either that the activity has no potential to cause effects to historic properties or that NHPA section 106 consultation has been completed.

(d) For non-federal permittees, the district engineer will notify the prospective permittee within 45 days of receipt of a complete pre-construction notification whether NHPA section 106 consultation is required. If NHPA section 106 consultation is required, the district engineer will notify the non-Federal applicant that he or she cannot begin the activity until section 106 consultation is completed. If the non-Federal applicant has not heard back from the Corps within 45 days, the applicant must still wait for notification from the Corps.

(e) Prospective permittees should be aware that section 110k of the NHPA (54 U.S.C. 306113) prevents the Corps from granting a permit or other assistance to an applicant who, with intent to avoid the requirements of section 106 of the NHPA, has intentionally significantly adversely affected a historic property to which the permit would relate, or having legal power to prevent it, allowed such significant adverse effect to occur, unless the Corps, after consultation with the Advisory Council on Historic

Preservation (ACHP), determines that circumstances justify granting such assistance despite the adverse effect created or permitted by the applicant. If circumstances justify granting the assistance, the Corps is required to notify the ACHP and provide documentation specifying the circumstances, the degree of damage to the integrity of any historic properties affected, and proposed mitigation. This documentation must include any views obtained from the applicant, SHPO/THPO, appropriate Indian tribes if the undertaking occurs on or affects historic properties on tribal lands or affects properties of interest to those tribes, and other parties known to have a legitimate interest in the impacts to the permitted activity on historic properties.

21. Discovery of Previously Unknown Remains and Artifacts. If you discover any previously unknown historic, cultural or archeological remains and artifacts while accomplishing the activity authorized by this permit, you must immediately notify the district engineer of what you have found, and to the maximum extent practicable, avoid construction activities that may affect the remains and artifacts until the required coordination has been completed. The district engineer will initiate the Federal, Tribal, and state coordination required to determine if the items or remains warrant a recovery effort or if the site is eligible for listing in the National Register of Historic Places.

22. Designated Critical Resource Waters. Critical resource waters include, NOAA-managed marine sanctuaries and marine monuments, and National Estuarine Research Reserves. The district engineer may designate, after notice and opportunity for public comment, additional waters officially designated by a state as having particular environmental or ecological significance, such as outstanding national resource waters or state natural heritage sites. The district engineer may also designate additional critical resource waters after notice and opportunity for public comment.

(a) Discharges of dredged or fill material into waters of the United States are not authorized by NWP 7, 12, 14, 16, 17, 21, 29, 31, 35, 39, 40, 42, 43, 44, 49, 50, 51, and 52 for any activity within, or directly affecting, critical resource waters, including wetlands adjacent to such waters.

(b) For NWPs 3, 8, 10, 13, 15, 18, 19, 22, 23, 25, 27, 28, 30, 33, 34, 36, 37, 38, and 54, notification is required in accordance with general condition 32, for any activity proposed in the designated critical resource waters including wetlands adjacent to those waters. The district engineer may authorize activities under these NWPs only after it is determined that the impacts to the critical resource waters will be no more than minimal.

23. Mitigation. The district engineer will consider the following factors when determining appropriate and practicable mitigation necessary to ensure that the individual and cumulative adverse environmental effects are no more than minimal:

(a) The activity must be designed and constructed to avoid and minimize adverse effects, both temporary and permanent, to waters of the United States to the maximum extent practicable at the project site (i.e., on site).

(b) Mitigation in all its forms (avoiding, minimizing, rectifying, reducing, or compensating for resource losses) will be required to the extent necessary to ensure that the individual and cumulative adverse environmental effects are no more than minimal.

(c) Compensatory mitigation at a minimum one-for-one ratio will be required for all wetland losses that exceed 1/10-acre and require pre-construction notification, unless the district engineer determines in writing that either some other form of mitigation would be more environmentally appropriate or the adverse environmental effects of the proposed activity are no more than minimal, and provides an activity-specific waiver of this requirement. For wetland losses of 1/10-acre or less that require pre-construction notification, the district engineer may determine on a case-by-case basis that compensatory mitigation is required to ensure that the activity results in only minimal adverse environmental effects.

(d) For losses of streams or other open waters that require pre-construction notification, the district engineer may require compensatory mitigation to ensure that the activity results in no more than minimal adverse environmental effects. Compensatory mitigation for losses of streams should be provided, if practicable, through stream rehabilitation, enhancement, or preservation, since streams are difficult-to-replace resources (see 33 CFR 332.3(e)(3)).

(e) Compensatory mitigation plans for NWP activities in or near streams or other open waters will normally include a requirement for the restoration or enhancement, maintenance, and legal protection (e.g., conservation easements) of riparian areas next to open waters. In some cases, the restoration or maintenance/protection of riparian areas may be the only compensatory mitigation required. Restored riparian areas should consist of native species. The width of the required riparian area will address documented water quality or aquatic habitat loss concerns. Normally, the riparian area will be 25 to 50 feet wide on each side of the stream, but the district engineer may require slightly wider riparian areas to address documented water quality or habitat loss concerns. If it is not possible to restore or maintain/protect a riparian area on both sides of a stream, or if the waterbody is a lake or coastal waters, then restoring or maintaining/protecting a riparian area along a single bank or shoreline may be sufficient. Where both wetlands and open waters exist on the project site, the district engineer will determine the appropriate compensatory mitigation (e.g., riparian areas and/or wetlands compensation) based on what is best for the aquatic environment on a watershed basis. In cases where riparian areas are determined to be the most appropriate form of minimization or compensatory mitigation, the district engineer may waive or reduce the requirement to provide wetland compensatory mitigation for wetland losses.

(f) Compensatory mitigation projects provided to offset losses of aquatic resources must comply with the applicable provisions of 33 CFR part 332.

(1) The prospective permittee is responsible for proposing an appropriate compensatory mitigation option if compensatory mitigation is necessary to ensure that

the activity results in no more than minimal adverse environmental effects. For the NWPs, the preferred mechanism for providing compensatory mitigation is mitigation bank credits or in-lieu fee program credits (see 33 CFR 332.3(b)(2) and (3)). However, if an appropriate number and type of mitigation bank or in-lieu credits are not available at the time the PCN is submitted to the district engineer, the district engineer may approve the use of permittee-responsible mitigation.

(2) The amount of compensatory mitigation required by the district engineer must be sufficient to ensure that the authorized activity results in no more than minimal individual and cumulative adverse environmental effects (see 33 CFR 330.1(e)(3)). (See also 33 CFR 332.3(f)).

(3) Since the likelihood of success is greater and the impacts to potentially valuable uplands are reduced, aquatic resource restoration should be the first compensatory mitigation option considered for permittee-responsible mitigation.

(4) If permittee-responsible mitigation is the proposed option, the prospective permittee is responsible for submitting a mitigation plan. A conceptual or detailed mitigation plan may be used by the district engineer to make the decision on the NWP verification request, but a final mitigation plan that addresses the applicable requirements of 33 CFR 332.4(c)(2) through (14) must be approved by the district engineer before the permittee begins work in waters of the United States, unless the district engineer determines that prior approval of the final mitigation plan is not practicable or not necessary to ensure timely completion of the required compensatory mitigation (see 33 CFR 332.3(k)(3)).

(5) If mitigation bank or in-lieu fee program credits are the proposed option, the mitigation plan only needs to address the baseline conditions at the impact site and the number of credits to be provided.

(6) Compensatory mitigation requirements (e.g., resource type and amount to be provided as compensatory mitigation, site protection, ecological performance standards, monitoring requirements) may be addressed through conditions added to the NWP authorization, instead of components of a compensatory mitigation plan (see 33 CFR 332.4(c)(1)(ii)).

(g) Compensatory mitigation will not be used to increase the acreage losses allowed by the acreage limits of the NWPs. For example, if an NWP has an acreage limit of 1/2-acre, it cannot be used to authorize any NWP activity resulting in the loss of greater than 1/2-acre of waters of the United States, even if compensatory mitigation is provided that replaces or restores some of the lost waters. However, compensatory mitigation can and should be used, as necessary, to ensure that an NWP activity already meeting the established acreage limits also satisfies the no more than minimal impact requirement for the NWPs.

(h) Permittees may propose the use of mitigation banks, in-lieu fee programs, or permittee-responsible mitigation. When developing a compensatory mitigation proposal, the permittee must consider appropriate and practicable options consistent with the framework at 33 CFR 332.3(b). For activities resulting in the loss of marine or estuarine resources, permittee-responsible mitigation may be environmentally preferable if there are no mitigation banks or in-lieu fee programs in the area that have marine or estuarine credits available for sale or transfer to the permittee. For permittee-responsible mitigation, the special conditions of the NWP verification must clearly indicate the party or parties responsible for the implementation and performance of the compensatory mitigation project, and, if required, its long-term management.

(i) Where certain functions and services of waters of the United States are permanently adversely affected by a regulated activity, such as discharges of dredged or fill material into waters of the United States that will convert a forested or scrub-shrub wetland to a herbaceous wetland in a permanently maintained utility line right-of-way, mitigation may be required to reduce the adverse environmental effects of the activity to the no more than minimal level.

24. Safety of Impoundment Structures. To ensure that all impoundment structures are safely designed, the district engineer may require non-Federal applicants to demonstrate that the structures comply with established state dam safety criteria or have been designed by qualified persons. The district engineer may also require documentation that the design has been independently reviewed by similarly qualified persons, and appropriate modifications made to ensure safety.

25. Water Quality. Where States and authorized Tribes, or EPA where applicable, have not previously certified compliance of an NWP with CWA section 401, individual 401 Water Quality Certification must be obtained or waived (see 33 CFR 330.4(c)). The district engineer or State or Tribe may require additional water quality management measures to ensure that the authorized activity does not result in more than minimal degradation of water quality.

26. Coastal Zone Management. In coastal states where an NWP has not previously received a state coastal zone management consistency concurrence, an individual state coastal zone management consistency concurrence must be obtained, or a presumption of concurrence must occur (see 33 CFR 330.4(d)). The district engineer or a State may require additional measures to ensure that the authorized activity is consistent with state coastal zone management requirements.

27. Regional and Case-By-Case Conditions. The activity must comply with any regional conditions that may have been added by the Division Engineer (see 33 CFR 330.4(e)) and with any case specific conditions added by the Corps or by the state, Indian Tribe, or U.S. EPA in its section 401 Water Quality Certification, or by the state in its Coastal Zone Management Act consistency determination.

28. Use of Multiple Nationwide Permits. The use of more than one NWP for a single and complete project is prohibited, except when the acreage loss of waters of the United States authorized by the NWPs does not exceed the acreage limit of the NWP with the highest specified acreage limit. For example, if a road crossing over tidal waters is constructed under NWP 14, with associated bank stabilization authorized by NWP 13, the maximum acreage loss of waters of the United States for the total project cannot exceed 1/3-acre.

29. Transfer of Nationwide Permit Verifications. If the permittee sells the property associated with a nationwide permit verification, the permittee may transfer the nationwide permit verification to the new owner by submitting a letter to the appropriate Corps district office to validate the transfer. A copy of the nationwide permit verification must be attached to the letter, and the letter must contain the following statement and signature:

"When the structures or work authorized by this nationwide permit are still in existence at the time the property is transferred, the terms and conditions of this nationwide permit, including any special conditions, will continue to be binding on the new owner(s) of the property. To validate the transfer of this nationwide permit and the associated liabilities associated with compliance with its terms and conditions, have the transferee sign and date below."

(Transferee)

(Date)

30. Compliance Certification. Each permittee who receives an NWP verification letter from the Corps must provide a signed certification documenting completion of the authorized activity and implementation of any required compensatory mitigation. The success of any required permittee-responsible mitigation, including the achievement of ecological performance standards, will be addressed separately by the district engineer. The Corps will provide the permittee the certification document with the NWP verification letter. The certification document will include:

(a) A statement that the authorized activity was done in accordance with the NWP authorization, including any general, regional, or activity-specific conditions;

(b) A statement that the implementation of any required compensatory mitigation was completed in accordance with the permit conditions. If credits from a mitigation bank or in-lieu fee program are used to satisfy the compensatory mitigation requirements, the certification must include the documentation required by 33 CFR 332.3(l)(3) to confirm that the permittee secured the appropriate number and resource type of credits; and

(c) The signature of the permittee certifying the completion of the activity and mitigation.

The completed certification document must be submitted to the district engineer within 30 days of completion of the authorized activity or the implementation of any required compensatory mitigation, whichever occurs later.

31. Activities Affecting Structures or Works Built by the United States. If an NWP activity also requires permission from the Corps pursuant to 33 U.S.C. 408 because it will alter or temporarily or permanently occupy or use a U.S. Army Corps of Engineers (USACE) federally authorized Civil Works project (a "USACE project"), the prospective permittee must submit a pre-construction notification. See paragraph (b)(10) of general condition 32. An activity that requires section 408 permission is not authorized by NWP until the appropriate Corps office issues the section 408 permission to alter, occupy, or use the USACE project, and the district engineer issues a written NWP verification.

32. Pre-Construction Notification. (a) Timing. Where required by the terms of the NWP, the prospective permittee must notify the district engineer by submitting a pre-construction notification (PCN) as early as possible. The district engineer must determine if the PCN is complete within 30 calendar days of the date of receipt and, if the PCN is determined to be incomplete, notify the prospective permittee within that 30 day period to request the additional information necessary to make the PCN complete. The request must specify the information needed to make the PCN complete. As a general rule, district engineers will request additional information necessary to make the PCN complete only once. However, if the prospective permittee does not provide all of the requested information, then the district engineer will notify the prospective permittee that the PCN is still incomplete and the PCN review process will not commence until all of the requested information has been received by the district engineer. The prospective permittee shall not begin the activity until either:

(1) He or she is notified in writing by the district engineer that the activity may proceed under the NWP with any special conditions imposed by the district or division engineer; or

(2) 45 calendar days have passed from the district engineer's receipt of the complete PCN and the prospective permittee has not received written notice from the district or division engineer. However, if the permittee was required to notify the Corps pursuant to general condition 18 that listed species or critical habitat might be affected or are in the vicinity of the activity, or to notify the Corps pursuant to general condition 20 that the activity might have the potential to cause effects to historic properties, the permittee cannot begin the activity until receiving written notification from the Corps that there is "no effect" on listed species or "no potential to cause effects" on historic properties, or that any consultation required under Section 7 of the Endangered Species Act (see 33 CFR 330.4(f)) and/or section 106 of the National Historic Preservation Act (see 33 CFR 330.4(g)) has been completed. Also, work cannot begin under NWPs 21, 49, or 50 until the permittee has received written approval from the Corps. If the proposed activity requires a written waiver to exceed specified limits of an NWP, the

permittee may not begin the activity until the district engineer issues the waiver. If the district or division engineer notifies the permittee in writing that an individual permit is required within 45 calendar days of receipt of a complete PCN, the permittee cannot begin the activity until an individual permit has been obtained. Subsequently, the permittee's right to proceed under the NWP may be modified, suspended, or revoked only in accordance with the procedure set forth in 33 CFR 330.5(d)(2).

(b) Contents of Pre-Construction Notification: The PCN must be in writing and include the following information:

(1) Name, address and telephone numbers of the prospective permittee;

(2) Location of the proposed activity;

(3) Identify the specific NWP or NWP(s) the prospective permittee wants to use to authorize the proposed activity;

(4) A description of the proposed activity; the activity's purpose; direct and indirect adverse environmental effects the activity would cause, including the anticipated amount of loss of wetlands, other special aquatic sites, and other waters expected to result from the NWP activity, in acres, linear feet, or other appropriate unit of measure; a description of any proposed mitigation measures intended to reduce the adverse environmental effects caused by the proposed activity; and any other NWP(s), regional general permit(s), or individual permit(s) used or intended to be used to authorize any part of the proposed project or any related activity, including other separate and distant crossings for linear projects that require Department of the Army authorization but do not require pre-construction notification. The description of the proposed activity and any proposed mitigation measures should be sufficiently detailed to allow the district engineer to determine that the adverse environmental effects of the activity will be no more than minimal and to determine the need for compensatory mitigation or other mitigation measures. For single and complete linear projects, the PCN must include the quantity of anticipated losses of wetlands, other special aquatic sites, and other waters for each single and complete crossing of those wetlands, other special aquatic sites, and other waters. Sketches should be provided when necessary to show that the activity complies with the terms of the NWP. (Sketches usually clarify the activity and when provided results in a quicker decision. Sketches should contain sufficient detail to provide an illustrative description of the proposed activity (e.g., a conceptual plan), but do not need to be detailed engineering plans);

(5) The PCN must include a delineation of wetlands, other special aquatic sites, and other waters, such as lakes and ponds, and perennial, intermittent, and ephemeral streams, on the project site. Wetland delineations must be prepared in accordance with the current method required by the Corps. The permittee may ask the Corps to delineate the special aquatic sites and other waters on the project site, but there may be a delay if the Corps does the delineation, especially if the project site is large or contains many wetlands, other special aquatic sites, and other waters. Furthermore, the

45 day period will not start until the delineation has been submitted to or completed by the Corps, as appropriate;

(6) If the proposed activity will result in the loss of greater than 1/10-acre of wetlands and a PCN is required, the prospective permittee must submit a statement describing how the mitigation requirement will be satisfied, or explaining why the adverse environmental effects are no more than minimal and why compensatory mitigation should not be required. As an alternative, the prospective permittee may submit a conceptual or detailed mitigation plan.

(7) For non-Federal permittees, if any listed species or designated critical habitat might be affected or is in the vicinity of the activity, or if the activity is located in designated critical habitat, the PCN must include the name(s) of those endangered or threatened species that might be affected by the proposed activity or utilize the designated critical habitat that might be affected by the proposed activity. For NWP activities that require pre-construction notification, Federal permittees must provide documentation demonstrating compliance with the Endangered Species Act;

(8) For non-Federal permittees, if the NWP activity might have the potential to cause effects to a historic property listed on, determined to be eligible for listing on, or potentially eligible for listing on, the National Register of Historic Places, the PCN must state which historic property might have the potential to be affected by the proposed activity or include a vicinity map indicating the location of the historic property. For NWP activities that require pre-construction notification, Federal permittees must provide documentation demonstrating compliance with section 106 of the National Historic Preservation Act;

(9) For an activity that will occur in a component of the National Wild and Scenic River System, or in a river officially designated by Congress as a "study river" for possible inclusion in the system while the river is in an official study status, the PCN must identify the Wild and Scenic River or the "study river" (see general condition 16); and

(10) For an activity that requires permission from the Corps pursuant to 33 U.S.C. 408 because it will alter or temporarily or permanently occupy or use a U.S. Army Corps of Engineers federally authorized civil works project, the pre-construction notification must include a statement confirming that the project proponent has submitted a written request for section 408 permission from the Corps office having jurisdiction over that USACE project.

(c) Form of Pre-Construction Notification: The standard individual permit application form (Form ENG 4345) may be used, but the completed application form must clearly indicate that it is an NWP PCN and must include all of the applicable information required in paragraphs (b)(1) through (10) of this general condition. A letter containing the required information may also be used. Applicants may provide

electronic files of PCNs and supporting materials if the district engineer has established tools and procedures for electronic submittals.

(d) Agency Coordination: (1) The district engineer will consider any comments from Federal and state agencies concerning the proposed activity's compliance with the terms and conditions of the NWP's and the need for mitigation to reduce the activity's adverse environmental effects so that they are no more than minimal.

(2) Agency coordination is required for: (i) all NWP activities that require pre-construction notification and result in the loss of greater than 1/2-acre of waters of the United States; (ii) NWP 21, 29, 39, 40, 42, 43, 44, 50, 51, and 52 activities that require pre-construction notification and will result in the loss of greater than 300 linear feet of stream bed; (iii) NWP 13 activities in excess of 500 linear feet, fills greater than one cubic yard per running foot, or involve discharges of dredged or fill material into special aquatic sites; and (iv) NWP 54 activities in excess of 500 linear feet, or that extend into the waterbody more than 30 feet from the mean low water line in tidal waters or the ordinary high water mark in the Great Lakes.

(3) When agency coordination is required, the district engineer will immediately provide (e.g., via e-mail, facsimile transmission, overnight mail, or other expeditious manner) a copy of the complete PCN to the appropriate Federal or state offices (FWS, state natural resource or water quality agency, EPA, and, if appropriate, the NMFS). With the exception of NWP 37, these agencies will have 10 calendar days from the date the material is transmitted to notify the district engineer via telephone, facsimile transmission, or e-mail that they intend to provide substantive, site-specific comments. The comments must explain why the agency believes the adverse environmental effects will be more than minimal. If so contacted by an agency, the district engineer will wait an additional 15 calendar days before making a decision on the pre-construction notification. The district engineer will fully consider agency comments received within the specified time frame concerning the proposed activity's compliance with the terms and conditions of the NWP's, including the need for mitigation to ensure the net adverse environmental effects of the proposed activity are no more than minimal. The district engineer will provide no response to the resource agency, except as provided below. The district engineer will indicate in the administrative record associated with each pre-construction notification that the resource agencies' concerns were considered. For NWP 37, the emergency watershed protection and rehabilitation activity may proceed immediately in cases where there is an unacceptable hazard to life or a significant loss of property or economic hardship will occur. The district engineer will consider any comments received to decide whether the NWP 37 authorization should be modified, suspended, or revoked in accordance with the procedures at 33 CFR 330.5.

(4) In cases of where the prospective permittee is not a Federal agency, the district engineer will provide a response to NMFS within 30 calendar days of receipt of any Essential Fish Habitat conservation recommendations, as required by section 305(b)(4)(B) of the Magnuson-Stevens Fishery Conservation and Management Act.

(5) Applicants are encouraged to provide the Corps with either electronic files or multiple copies of pre-construction notifications to expedite agency coordination.

B. District Engineer's Decision

1. In reviewing the PCN for the proposed activity, the district engineer will determine whether the activity authorized by the NWP will result in more than minimal individual or cumulative adverse environmental effects or may be contrary to the public interest. If a project proponent requests authorization by a specific NWP, the district engineer should issue the NWP verification for that activity if it meets the terms and conditions of that NWP, unless he or she determines, after considering mitigation, that the proposed activity will result in more than minimal individual and cumulative adverse effects on the aquatic environment and other aspects of the public interest and exercises discretionary authority to require an individual permit for the proposed activity. For a linear project, this determination will include an evaluation of the individual crossings of waters of the United States to determine whether they individually satisfy the terms and conditions of the NWP(s), as well as the cumulative effects caused by all of the crossings authorized by NWP. If an applicant requests a waiver of the 300 linear foot limit on impacts to streams or of an otherwise applicable limit, as provided for in NWPs 13, 21, 29, 36, 39, 40, 42, 43, 44, 50, 51, 52, or 54, the district engineer will only grant the waiver upon a written determination that the NWP activity will result in only minimal individual and cumulative adverse environmental effects. For those NWPs that have a waivable 300 linear foot limit for losses of intermittent and ephemeral stream bed and a 1/2-acre limit (i.e., NWPs 21, 29, 39, 40, 42, 43, 44, 50, 51, and 52), the loss of intermittent and ephemeral stream bed, plus any other losses of jurisdictional waters and wetlands, cannot exceed 1/2-acre.

2. When making minimal adverse environmental effects determinations the district engineer will consider the direct and indirect effects caused by the NWP activity. He or she will also consider the cumulative adverse environmental effects caused by activities authorized by NWP and whether those cumulative adverse environmental effects are no more than minimal. The district engineer will also consider site specific factors, such as the environmental setting in the vicinity of the NWP activity, the type of resource that will be affected by the NWP activity, the functions provided by the aquatic resources that will be affected by the NWP activity, the degree or magnitude to which the aquatic resources perform those functions, the extent that aquatic resource functions will be lost as a result of the NWP activity (e.g., partial or complete loss), the duration of the adverse effects (temporary or permanent), the importance of the aquatic resource functions to the region (e.g., watershed or ecoregion), and mitigation required by the district engineer. If an appropriate functional or condition assessment method is available and practicable to use, that assessment method may be used by the district engineer to assist in the minimal adverse environmental effects determination. The district engineer may add case-specific special conditions to the NWP authorization to address site-specific environmental concerns.

3. If the proposed activity requires a PCN and will result in a loss of greater than 1/10-acre of wetlands, the prospective permittee should submit a mitigation proposal

with the PCN. Applicants may also propose compensatory mitigation for NWP activities with smaller impacts, or for impacts to other types of waters (e.g., streams). The district engineer will consider any proposed compensatory mitigation or other mitigation measures the applicant has included in the proposal in determining whether the net adverse environmental effects of the proposed activity are no more than minimal. The compensatory mitigation proposal may be either conceptual or detailed. If the district engineer determines that the activity complies with the terms and conditions of the NWP and that the adverse environmental effects are no more than minimal, after considering mitigation, the district engineer will notify the permittee and include any activity-specific conditions in the NWP verification the district engineer deems necessary. Conditions for compensatory mitigation requirements must comply with the appropriate provisions at 33 CFR 332.3(k). The district engineer must approve the final mitigation plan before the permittee commences work in waters of the United States, unless the district engineer determines that prior approval of the final mitigation plan is not practicable or not necessary to ensure timely completion of the required compensatory mitigation. If the prospective permittee elects to submit a compensatory mitigation plan with the PCN, the district engineer will expeditiously review the proposed compensatory mitigation plan. The district engineer must review the proposed compensatory mitigation plan within 45 calendar days of receiving a complete PCN and determine whether the proposed mitigation would ensure the NWP activity results in no more than minimal adverse environmental effects. If the net adverse environmental effects of the NWP activity (after consideration of the mitigation proposal) are determined by the district engineer to be no more than minimal, the district engineer will provide a timely written response to the applicant. The response will state that the NWP activity can proceed under the terms and conditions of the NWP, including any activity-specific conditions added to the NWP authorization by the district engineer.

4. If the district engineer determines that the adverse environmental effects of the proposed activity are more than minimal, then the district engineer will notify the applicant either: (a) that the activity does not qualify for authorization under the NWP and instruct the applicant on the procedures to seek authorization under an individual permit; (b) that the activity is authorized under the NWP subject to the applicant's submission of a mitigation plan that would reduce the adverse environmental effects so that they are no more than minimal; or (c) that the activity is authorized under the NWP with specific modifications or conditions. Where the district engineer determines that mitigation is required to ensure no more than minimal adverse environmental effects, the activity will be authorized within the 45-day PCN period (unless additional time is required to comply with general conditions 18, 20, and/or 31, or to evaluate PCNs for activities authorized by NWPs 21, 49, and 50), with activity-specific conditions that state the mitigation requirements. The authorization will include the necessary conceptual or detailed mitigation plan or a requirement that the applicant submit a mitigation plan that would reduce the adverse environmental effects so that they are no more than minimal. When compensatory mitigation is required, no work in waters of the United States may occur until the district engineer has approved a specific mitigation plan or has determined that prior approval of a final mitigation plan is not practicable or not necessary to ensure timely completion of the required compensatory mitigation.

C. Further Information

1. District Engineers have authority to determine if an activity complies with the terms and conditions of an NWP.

2. NWPs do not obviate the need to obtain other federal, state, or local permits, approvals, or authorizations required by law.

3. NWPs do not grant any property rights or exclusive privileges.

4. NWPs do not authorize any injury to the property or rights of others.

5. NWPs do not authorize interference with any existing or proposed Federal project (see general condition 31).

STATE OF MISSISSIPPI
NATIONWIDE PERMIT REGIONAL CONDITIONS

A. REGIONAL CONDITIONS FOR ALL NATIONWIDE PERMITS

1. For ALL Nationwide Permit (NWP) authorizations in the Coastal Zone of Mississippi (Hancock, Harrison, and Jackson Counties):

The applicant must contact the Mississippi Department of Marine Resources (MDMR) for concurrence that proposed activities under the NWP are consistent to the maximum extent practicable with the enforceable policies of the State of Mississippi's coastal management program. Applicants are advised that additional measures may be required to ensure the activity is consistent with State coastal zone management program. If a Coastal Zone Management Act Consistency Determination (CZCD) is required: (1) the applicant shall submit their proposed project information directly to MDMR using the Joint Application & Notification form with a consistency determination; (2) the applicant is required to receive the CZCD concurrence prior to project initiation to achieve compliance with NWP conditions; (3) upon receipt of the CZCD concurrence from MDMR, the applicant must provide the CZCD concurrence to the applicable Corps District.

The Joint Application and Notification form may be downloaded or printed from the MDMR website at: <http://www.dmr.ms.gov/index.php/coastal-resources-management/wetland-permitting>

If a pre-construction notification (PCN) to the Corps is required, the attachment to these Regional Conditions highlights the minimum additional information needed.

The completed submittal shall be sent directly to MDMR at the following address:

Mississippi Department of Marine Resources
Bureau of Wetlands Permitting
1141 Bayview Drive
Biloxi, Mississippi 39530

2. A PCN to the appropriate Corps District is required for all regulated activities located within or adjacent to Black Creek within the reach beginning approximately ¼-mile upstream of Moody's Landing and ending approximately ¼-mile downstream of the Fairly Road Bridge crossing. The Corps will coordinate the PCN with the National Forest Service per requirements of Section 7 of the Wild and Scenic Rivers Act and General Condition 16 of the NWPs.

3. NWP authorizations for regulated activities in the Grand Bay National Estuarine Research Reserve, a designated critical resource water located in Jackson County, Mississippi, shall adhere to General Condition 22 of the NWPs.

Effective March 19, 2017

Enclosure 4

4. For all regulated activities that might affect a federally-listed threatened or endangered species or designated critical habitat, or essential fish habitat:

Submittal of a complete PCN to the appropriate Corps District is required. Note: For activities in waters described in Regional Condition A.1., all PCNs shall instead be submitted directly to MDMR using the Joint Application and Notification form and include information required by NWP General Condition 32. Waterways in Mississippi with reported occurrences of federally-listed threatened or endangered species and their critical habitats, as of March 2017, are listed below. The list below also includes certain types of essential fish habitat (EFH) for federally-managed fisheries that may occur in coastal waterways. This list is provided to heighten awareness of the possibility of interaction between federally-protected species/habitats and regulated activities; it is not intended to be all-inclusive. Applicants are advised that the federal protection status of species and habitats may change during the time period in which these Regional Conditions are in effect, and that those changes may not be reflected in the list below.

Further, this Regional Condition does not lessen the restrictions or requirements provided by General Condition 18. As stated in General Conditions 18 and 32 (82 FR 1860-2008), the PCN from non-federal applicants must include a delineation of waters of the U.S. in the project area and the name(s) of the threatened or endangered species that might be affected by the proposed work or that utilize designated critical habitat that might be affected by the proposed work. PCNs from federal applicants must include documentation of compliance with the Endangered Species Act and Magnuson-Stevens Fishery Conservation and Management Act (MSFCMA), as applicable.

NOTE: The following definitions apply to the list below, as well as the list in Section B.1. of these Regional Conditions: C = Candidate Species; CH = Critical Habitat; LE = Listed Endangered; LT = Listed Threatened; PT = Proposed Threatened; EFH = Waters and substrate necessary to MSFCMA-protected fish for spawning, breeding, feeding, or growth to maturity.

Bayou Pierre River and following tributaries: White Oak Creek, Foster Creek, and Turkey Creek – Located in Claiborne, Copiah, Hinds and Lincoln Counties
Species: bayou darter (*Etheostoma rubrum* - LT)

Bear Creek – Located in Tishomingo County
Species: cumberlandian combshell mussel (*Epioblasma brevidens* – LE, CH); slabside pearl mussel (*Lexingonia dolabellodes* – LE, CH), rabbitsfoot mussel (*Quadrula cylindrica cylindrica* – LT, CH), snuffbox mussel (*Epioblasma triquetra* - LE) and snail darter (*Percina tanasi* – LT)

Big Black River – Located in Hinds and Warren Counties, from Porter Creek confluence south to Highway 27
Species: rabbitsfoot mussel (*Quadrula cylindrica cylindrica* – LT, CH)

Big Sunflower River – Located in Sunflower County, from Highway 442 to Quiver River confluence

Species: rabbitsfoot mussel (*Quadrula cylindrica cylindrica* – LT, CH) and sheepsnose mussel (*Plethobasus cyphus*- LE)

Bogue Chitto River – Located in Pike and Walthall Counties, from State Highway 570, southward

Species: Gulf sturgeon (*Acipenser oxyrinchus desotoi* - LT, CH)

Mississippi River and adjacent land west of the mainline levee – Located in the following Counties: Adams, Coahoma, Jefferson, Warren, Bolivar, DeSoto, Sharkey, Washington, Claiborne, Issaquena, Tunica, and Wilkinson

Species: interior least tern (*Sterna antillarum* - LE), pallid sturgeon (*Scaphirhynchus albus* - LE), and fat pocketbook mussel (*Potamilus capax* - LE)

MS Coastal Waterways and Streams including: Back Bay of Biloxi, Biloxi River, Escatawpa River, Old Fort Bayou, Pascagoula River, and Tchoutacabouffa River – Located in Harrison and Jackson Counties

Species: Alabama red-bellied turtle (*Pseudemys alabamensis* - LE)

EFH: estuarine emergent wetlands, submersed aquatic vegetation or vegetated shallows, live bottoms (e.g. oyster bars, limestone outcroppings)

Mississippi Sound and other back bays – Located in Hancock, Harrison, and Jackson Counties

Species: piping plover (*Charadrius melodus* - LE, CH), red knot (*Calidris canutus rufa* – LT), West Indian manatee (*Trichechus manatus* – LE), green turtle (*Chelonia mydas* - LT), Kemp's ridley turtle (*Lepidochelys kempii* - LE), leatherback sea turtle (*Dermochelys coriacea* – LE), loggerhead turtle (*Caretta caretta* - LT), and Gulf sturgeon (*Acipenser oxyrinchus desotoi* - LT, CH)

EFH: estuarine emergent wetlands, submersed aquatic vegetation or vegetated shallows, live bottoms (e.g. oyster bars, limestone outcroppings)

Pascagoula River and the following tributaries: Bouie, Chickasawhay, Okatoma, and Leaf Rivers – Located in the following Counties: Clarke, Greene, Perry, Forrest, Jackson, Stone, George, Jones, and Wayne

Species: yellow-blotched map turtle (*Graptemys flavimaculata* - LT), Gulf sturgeon (*Acipenser oxyrinchus desotoi* - LT, CH), pearl darter (*Percina aurora* - PT), and Alabama red-bellied turtle (*Pseudemys alabamensis* - LE)

EFH: estuarine emergent wetlands, submersed aquatic vegetation or vegetated shallows, live bottoms (e.g. oyster bars, limestone outcroppings)

Pearl River – Located in the following Counties: Copiah, Leake, Neshoba, Scott, Hinds, Madison, Pearl River, Hancock, Simpson, Lawrence, Marion, and Rankin

Species: ringed map turtle (*Graptemys oculifera* - LT), Gulf sturgeon (*Acipenser oxyrinchus desotoi* - LE, CH), and inflated heelsplitter (*Potamilus inflatus* - LT)

EFH: estuarine emergent wetlands, submersed aquatic vegetation, live bottoms (e.g. oyster bars, limestone outcroppings)

Tombigbee River and the following tributaries: Buttahatchie, Luxapalilla, Noxubee, and Bull Mountain – Located in Itawamba, Lowndes and Monroe Counties
Species: heavy pigtoe mussel (*Pleurobema taitianum* - LE), southern combshell mussel (*Epioblasma penita* - LE), southern clubshell mussel (*Pleurobema decisum* - LE), ovate clubshell mussel (*Pleurobema perovatum* - LT), black clubshell mussel (*Pleurobema curtum* - LE), Alabama moccasinshell (*Medionidus acutissimus* - LT), orange-nacre mucket (*Lampsilis perovalis* - LT), and inflated heelsplitter (*Potamilus inflatus* - LT)

5. Supplement to General Condition 2 (Aquatic Life Movements) and General Condition 9 (Management of Water Flows)

Culverts must be of sufficient capacity to maintain expected high and low water flows and be installed at a sufficient depth to not substantially disrupt the necessary life cycle movements of aquatic life species.

B. REGIONAL CONDITIONS FOR SPECIFIC NATIONWIDE PERMITS

1. For all NWP 12 and NWP 14 regulated activities that require a PCN:

To assess all individual and cumulative impacts, complete PCNs must include a description of the anticipated direct and indirect environmental effects, including both temporary and permanent impacts at all single and complete crossings of waters of the U.S. which are a part of the total linear project.

2. NWP 12 (Utility Line Activities) and NWP 14 (Linear Transportation Projects)

Submittal of a complete PCN to the appropriate Corps District is required for all regulated activities that may directly or indirectly affect federally-listed species and/or their designated critical habitat. The list below includes some species that could be encountered along a linear project and a general description of their typical habitat types utilized. This list is provided to heighten awareness of the possibility of interaction between federally-protected species/habitats and regulated activities; it is not intended to be all-inclusive. Applicants are advised that the federal protection status of species and habitats may change during the time period in which these Regional Conditions are in effect, and that those changes may not be reflected in the list below. NOTE: For regulated activities in waters described in Regional Condition A.1., all PCNs shall instead be submitted directly to MDMR using the Joint Application and Notification form, and include information required by NWP General Condition 32. The attachment to these Regional Conditions highlights the minimum additional information needed.

Gopher tortoise (*Gopherus polyphemus* - LT), and black pine snake (*Pituophis melanoleucus lodingi* - LT) – Located in Clarke, Covington, Forrest, George, Greene, Hancock, Harrison, Jackson, Jasper, Jefferson Davis, Jones, Lamar, Marion, Pearl River, Perry, Smith, Stone, Walthall, and Wayne Counties and associated with certain upland habitats that may be adjacent to wetlands and/or other waters of the U.S.

Louisiana quillwort (*Isoetes louisianaensis* - LE) – Located in Forrest, George, Greene, Hancock, Harrison, Jackson, Jones, Pearl River, Perry, Stone, and Wayne Counties and associated with intermittent and small perennial streams

Dusky gopher frog (*Rana sevosa* – LE, CH) – Located in Jackson, Forrest, Perry, and Harrison Counties and associated with isolated ephemeral (temporary) ponds/wetlands located in upland long-leaf pine habitat

Mississippi sandhill crane (*Grus canadensis pulla* – LE) – Located in Jackson County and associated with pine savannas, brackish marsh, cultivated fields, and pasture lands within 5 miles of the Mississippi Sandhill Crane National Wildlife Refuge

Mitchell's satyr butterfly (*Neonympha mitchellii mitchellii* – LE) – Located in Alcorn, Itawamba, Monroe, Prentiss, and Tishomingo Counties and associated with wetlands created by beaver ponds and other similar habitats

Gray bat (*Myotis grisescens* – LE), Indiana bat (*Myotis sodalis* - LE) and Northern Long-eared bat (*Myotis septentrionalis* – LT), – Located in counties north of Interstate 20 and associated with caves, box culverts, bridges, and/or forested uplands, wetlands, and riparian habitats (trees over 5 inches dbh)

Pondberry (*Lindera melissifolia* - LE) - Located in Bolivar, Coahoma, Holmes, Humphreys, Issaquena, Leflore, Quitman, Sharkey, Sunflower, Tallahatchie, Tunica, Warren, Washington, and Yazoo Counties and associated with bottomland hardwood wetlands

Price's potato bean (*Apios priceana* - LT) – Located in Alcorn, Chickasaw, Clay, Kemper, Lee, Lowndes, Monroe, Noxubee, Oktibbeha, Pontotoc, Prentiss, and Union Counties and associated with wooded areas that grade into creek and river bottoms

Red-cockaded woodpecker (*Picoides borealis* - LE) – Located in Amite, Copiah, Forrest, Franklin, George, Greene, Harrison, Jackson, Jasper, Jefferson, Jones, Lamar, Lincoln, Noxubee, Oktibbeha, Pearl River, Perry, Scott, Smith, Stone, Wayne, Wilkinson, and Winston Counties (primarily found on or near US National Forests and the Noxubee National Wildlife Refuge); Species excavates nesting cavities in mature pine trees (60+ years old)

Wood stork (*Mycteria americana* - LT) – Located Statewide and associated with freshwater marshes, tidal pools, cypress swamps; Species does not breed in MS, foraging habitat only

White fringeless orchid (*Platanthera integrilabia* – C) – Located in Alcorn, Itawamba, Monroe, Prentiss, and Tishomingo Counties and associated with wet boggy areas at heads of streams and on seepage slopes that are partially shaded

3. NWP 21 (Surface Coal Mining Activities)

This NWP, via disavowal of water quality certification by the Mississippi Department of Environmental Quality, is considered **denied without prejudice**. Individual requests for approval under this NWP will be considered on a case-by-case basis only after receipt by the appropriate Corps district of an individual water quality certification, waiver, or other approval by the Mississippi Department of Environmental Quality.

4. NWP 44 (Mining Activities)

This NWP, via disavowal of water quality certification by the Mississippi Department of Environmental Quality, is considered **denied without prejudice**. Individual requests for approval under this NWP will be considered on a case-by-case basis only after receipt by the appropriate Corps district of an individual water quality certification, waiver, or other approval by the Mississippi Department of Environmental Quality.

C. REGIONAL CONDITIONS FOR WATER QUALITY CERTIFICATION FOR MISSISSIPPI BAND OF CHOCTAW INDIANS TRIBAL LANDS

By letter dated March 2, 2017, the Environmental Protection Agency (EPA), Region 4, acting on behalf the Mississippi Band of Choctaw Indians, issued final decisions on water quality certification for Nationwide Permit (NWP) activities on Mississippi Band of Choctaw Indians (MBCI) Tribal Lands.

D. REGIONAL CONDITIONS FOR WATER QUALITY CERTIFICATION

By letters to the Corps dated March 6, 2017, the Mississippi Department of Environmental Quality (MDEQ) issued its final decisions on WQC for use of each of the NWPs in Mississippi.

E. REGIONAL CONDITIONS FOR COASTAL ZONE MANAGEMENT ACT CONSISTENCY

The applicant must contact the Mississippi Department of Marine Resources (MDMR) for concurrence that proposed activities under the NWP are consistent to the maximum extent practicable with the enforceable policies of the State of Mississippi's coastal management program. In accordance with Corps regulations at 33 CFR 330.4(d), if MDMR does not concur with the Corps determinations for use of a NWP in Mississippi, then the Corps will deny authorizations for the regulated activities that would affect coastal resources by the NWP within the State without prejudice. Under these "denial" situations, anyone wanting to perform such regulated activities would be required to first obtain an activity-specific CZMA consistency determination or waiver thereof from MDMR before proceeding under the NWP.

For those NWP's that MDMR concurs with the Corps' consistency determination, any associated conditions deemed necessary by MDMR to ensure that proposed activities under the NWP are consistent to the maximum extent practicable with the enforceable policies of the State of Mississippi's coastal management program will be reviewed by the Corps to assure the conditions are reasonably implementable or enforceable.

As per 33 CFR 330.4(c), if the Corps accepts MDMR's consistency conditions, the conditions will become Regional Conditions for the NWP activities which may result in a regulated work, structures, and/or discharges into waters of the U.S. in Mississippi, and the Regional Conditions will be attached to the NWP verification letter(s).

If the Corps determines that the consistency determination(s) and the associated conditions (for the NWP activities which may result in a regulated work, structures, and/or regulated discharge into waters of the U.S. in Mississippi) are not reasonably implementable or enforceable, according to 33 CFR 325.4(c), the Corps will consider the determination(s) denied without prejudice, and work may not proceed under the NWP(s) until the permittee obtains an individual CZMA consistency determination or waiver thereof.

F. NWPs NOT APPLICABLE IN MISSISSIPPI

The Vicksburg District, as Lead Corps District for Mississippi, determined that NWP 8 (Oil and Gas Structures on the Outer Continental Shelf) and NWP 24 (Indian Tribe or State Administered Section 404 Programs) are not applicable for Department of the Army permit requirements in Mississippi.

Attachment
Joint Application and Notification Form – Minimum Additional Information Requirements for NWPs, as per General Condition 32 (PCN Requirements)

- (1) The PCN must include a delineation of wetlands, other special aquatic sites (e.g. mudflats, vegetated shallows, sanctuaries, refuges), and other waters, such as lakes and ponds, and perennial, intermittent, and ephemeral streams, on the project site. Wetland delineations must be prepared in accordance with the current method required by the Corps. The applicant may ask the Corps to delineate the special aquatic sites and other waters on the project site, but there may be a delay if the Corps does the delineation, especially if the project site is large or contains many waters of the U.S. Furthermore, the 45 day period will not start until the delineation has been submitted to or completed by the Corps, as appropriate.
- (2) If the proposed activity will result in the loss of greater than 1/10-acre of wetlands, the applicant must submit a statement describing how the mitigation requirement will be satisfied, or explaining why the adverse effects are minimal and why compensatory mitigation should not be required. As an alternative, the applicant may submit a conceptual or detailed mitigation plan.
- (3) If any federally listed threatened or endangered species might be affected or is in the vicinity of the regulated activity, or if the regulated activity is located in designated critical habitat, for non-federal applicants the PCN must include the name(s) of those endangered or threatened species that might be affected or might utilize the designated critical habitat that may be affected by the proposed regulated activity. Federal applicants must provide documentation demonstrating compliance with the Endangered Species Act.
- (4) For a regulated activity that may affect a historic property listed on, determined to be eligible for listing on, or potentially eligible for listing on, the National Register of Historic Places, for non-federal applicants the PCN must state which historic property may be affected by the proposed regulated activity or include a vicinity map indicating the location of the historic property. Federal applicants must provide documentation demonstrating compliance with Section 106 of the National Historic Preservation Act.



STATE OF MISSISSIPPI

PHIL BRYANT
GOVERNOR

MISSISSIPPI DEPARTMENT OF ENVIRONMENTAL QUALITY

GARY C. RIKARD, EXECUTIVE DIRECTOR

March 6, 2017

Certified Mail No. 7012 3460 0003 2548 6902

Ms. Jennifer Mallard
Regulatory Branch Chief
U.S. Army Corps of Engineers
Vicksburg District
4155 Clay Street
Vicksburg, Mississippi 39183

Dear Ms. Mallard:

Re: U.S. Army Corps of Engineers
Nationwide Permit No. 23
Warren County
COE No. MVK-2017-114
WQC No. WQC2017023

Pursuant to Section 401 of the Federal Water Pollution Control Act (33 U. S. C. 1251, 1341), the Office of Pollution Control (OPC) issues this Certification, after public notice and opportunity for public hearing, to the U.S. Army Corps of Engineers, an applicant for a Federal License or permit to conduct the following activity:

US Army Corps of Engineers, Nationwide Permit No. 23:

Nationwide Permits are general permits issued on a nationwide basis to streamline the authorization of activities that have no more than minimal and cumulative adverse effects on the aquatic environment. The U.S. Army Corps of Engineers issues NWP's to authorize certain activities that require Department of the Army permits under Section 404 of the Clean Water Act and/or Section 10 of the Rivers and Harbors Act of 1899.

23. *Approved Categorical Exclusions.* Activities undertaken, assisted, authorized, regulated, funded, or financed, in whole or in part, by another Federal agency or department where:

(a) That agency or department has determined, pursuant to the Council on Environmental Quality's implementing regulations for the

National Environmental Policy Act (40 CFR part 1500 et seq.), that the activity is categorically excluded from the requirement to prepare an environmental impact statement or environmental assessment analysis, because it is included within a category of actions which neither individually nor cumulatively have a significant effect on the human environment; and

(b) The Office of the Chief of Engineers (Attn: CECW-CO) has concurred with that agency's or department's determination that the activity is categorically excluded and approved the activity for authorization under NWP 23.

The Office of the Chief of Engineers may require additional conditions, including pre-construction notification, for authorization of an agency's categorical exclusions under this NWP.

Notification: Certain categorical exclusions approved for authorization under this NWP require the permittee to submit a pre-construction notification to the district engineer prior to commencing the activity (see general condition 32). The activities that require pre-construction notification are listed in the appropriate Regulatory Guidance Letters.

Note: The agency or department may submit an application for an activity believed to be categorically excluded to the Office of the Chief of Engineers (Attn: CECW-CO). Prior to approval for authorization under this NWP of any agency's activity, the Office of the Chief of Engineers will solicit public comment. As of the date of issuance of this NWP, agencies with approved categorical exclusions are: the Bureau of Reclamation, Federal Highway Administration, and U.S. Coast Guard. Activities approved for authorization under this NWP as of the date of this notice are found in Corps Regulatory Guidance Letter 05-07, which is available at: <http://www.usace.army.mil/Portals/2/docs/civilworks/RGLS/rgl05-07.pdf>. Any future approved categorical exclusions will be announced in Regulatory Guidance Letters and posted on this same Web site. [MVK-2017-114, WQC2017023].

The Office of Pollution Control certifies that the above-described activity will be in compliance with the applicable provisions of Sections 301, 302, 303, 306, and 307 of the Federal Water Pollution Control Act and Section 49-17-29 of the Mississippi Code of 1972, if the applicant complies with the following conditions:

1. The permittee shall obtain appropriate wastewater permits and/or approvals for the proposed activity prior to the commencement of construction activities.
2. For projects greater than five acres of total ground disturbances including clearing, grading, excavating, or other construction activities, the applicant shall obtain the necessary coverage under the State of Mississippi's Large Construction Storm Water General NPDES Permit. For projects greater than one, to less the five acres of total ground disturbances including clearing, grading, excavating, or other construction activities, the applicant shall follow the conditions and limitations of the State of Mississippi's Small Construction Storm Water General NPDES Permit. No construction activities shall begin until the necessary approvals and/or permits have been obtained.
3. No sewage, oil, refuse, or other pollutants shall be discharged into the watercourse.
4. The turbidity outside the limits of a 750-foot mixing zone shall not exceed the ambient turbidity by more than 50-Nephelometric Turbidity Units.

The Office of Pollution Control also certifies that there are no limitations under Section 302 nor standards under Sections 306 and 307 of the Federal Water Pollution Control Act which are applicable to the applicant's above-described activity.

This certification is valid for the project as proposed. Any deviations without proper modifications and/or approvals may result in a violation of the 401 Water Quality Certification. If we can be of further assistance, please contact us.

Sincerely,

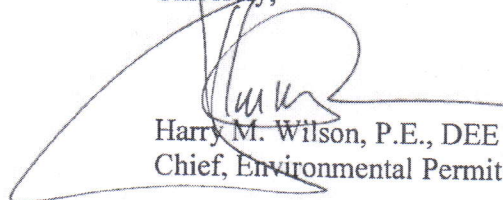

Harry M. Wilson, P.E., DEE
Chief, Environmental Permits Division

HMW: ld

Ms. Mallard
Page 4 of 4
March 6, 2017

cc: U.S. Army Corps of Engineers, Mobile District
Attn: Mr. Craig Litteken
U.S. Army Corps of Engineers, Memphis District
Attn: Mr. Tim Fudge
U.S. Army Corps of Engineers, Nashville District
Attn: Mr. Timothy Wilder
U.S. Army Corps of Engineers, New Orleans District
Attn: Mr. Michael Farabee
Ms. Willa Brantley, Department of Marine Resources
Mr. David Felder, U.S. Fish and Wildlife Service
Mr. William Ainsley, Environmental Protection Agency