

MDOT Use Only

Checked _____

Loaded _____

Keyed _____

08 -



SM No. CSP0835000061

PROPOSAL AND CONTRACT DOCUMENTS

FOR THE CONSTRUCTION OF

08

Full Depth Reclamation & DBST approximately 10 miles of SR 316 from the BOSM in Jonestown to SR 6 / US 278, known as State Project Nos. SP-0835-00(006) / 109224301 & SP-0835-00(007) / 109224302 in Coahoma & Quitman Counties.

Project Completion: Flexible

(STATE DELEGATED)

NOTICE

**BIDDERS MUST COMPLETE AN ONLINE REQUEST
FOR PERMISSION TO BID THIS PROJECT.**

Electronic addendum updates will be posted on www.gomdot.com

SECTION 900

OF THE CURRENT

2017 STANDARD SPECIFICATIONS

FOR ROAD AND BRIDGE CONSTRUCTION

JACKSON, MISSISSIPPI

**MISSISSIPPI DEPARTMENT OF TRANSPORTATION
TABLE OF CONTENTS**

**PROJECT: SP-0835-00(006)/109224301 - Coahoma
SP-0835-00(007)/109224302 - Quitman**

Section 901 - Advertisement

Section 904 - Notice to Bidders

#1	Governing Specification, w/ Supplement
#3	Final Cleanup
#9	Federal Bridge Formula
#32	Chip Seal Signs
#296	Reduced Speed Limit Signs
#445	Mississippi Agent or Qualified Nonresident Agent
#516	Errata and Modifications to the 2017 Standard Specifications
#1225	Early Notice to Proceed
#1226	Material Storage Under Bridges
#1241	Fuel and Material Adjustments
#2206	MASH Compliant Devices
#2273	Mississippi Special Fuel Tax Law
#2654	Disadvantaged Business Enterprises In Special Funded Projects, w/ Supplement
#2954	Reflective Sheeting for Signs
#3318	DBE Prebid Meeting
#3599	Standard Drawings, w/ Supplement
#4702	App for Traffic Control Report
#5086	Detail of Square Tube Sign Posts
#5133	Contract Time
#5134	Scope of Work

Section 907 - Special Provisions

907-102-2	Bidding Requirements and Conditions
907-103-2	Award and Execution of Contract
907-105-1	Authority of the Engineer
907-108-4	Subletting of Contract
907-109-4	Measurement and Payment
907-410-4	Bituminous Surface Treatment
907-414-1	Polymer Modified Asphalt Rejuvenating Scrub Seal
907-424-1	Roadbed Reclamation with Cement
907-618-4	Additional Signing Requirements, w/Supplement
907-619-5	Traffic Control for Construction Zones
907-701-3	Hydraulic Cement
907-702-4	Bituminous Materials
907-703-2	Gradation
907-705-1	Stone Riprap
907-707-3	Joint Materials
907-711-2	Plain Steel Wire
907-712-1	Fence and Guardrail
907-714-3	Miscellaneous Materials
907-718-1	Timber and Dimension Lumber

PROJECT: SP-0835-00(006)/109224301 - Coahoma
SP-0835-00(007)/109224302 - Quitman

907-720-2 Acceptance Procedure for Glass Beads
907-721-4 Materials for Signing

Section 905 - Proposal, Proposal Bid Items, Combination Bid Proposal
State Board of Contractors Requirement
State Certification Regarding Non-Collusion, Debarment and Suspensions
Section 902 - Contract Form
Section 903 - Contract Bond Forms

OCR-485
Progress Schedule

(REVISIONS TO THE ABOVE WILL BE INDICATED ON THE SECOND SHEET
OF SECTION 905 AS ADDENDA)

06/29/2023 09:54 AM

MISSISSIPPI DEPARTMENT OF TRANSPORTATION

SECTION 901 - ADVERTISEMENT

Electronic bids will be received by the Mississippi Transportation Commission at 10:00 o'clock A.M., Tuesday, July 25, 2023, from the Bid Express Service and shortly thereafter publicly read on the Sixth Floor for:

Full Depth Reclamation & DBST approximately 10 miles of SR 316 from the BOSM in Jonestown to SR 6 / US 278, known as State Project Nos. SP-0835-00(006) / 109224301 & SP-0835-00(007) / 109224302 in Coahoma & Quitman Counties.

The attention of bidders is directed to the predetermined minimum wage rate set by the U. S. Department of Labor under the Fair Labor Standards Act.

The Mississippi Department of Transportation hereby notifies all bidders that it will affirmatively insure that in any contract entered into pursuant to this advertisement, disadvantaged business enterprises will be afforded full opportunity to submit bids in response to this invitation and will not be discriminated against on the grounds of race, color, sex, age, disability, religion or national origin in consideration for an award.

The specifications are on file in the offices of the Mississippi Department of Transportation.

Contractors may request permission to bid online at <http://shop.mdot.ms.gov> at no cost. Upon approval, Contractors shall be eligible to submit a bid using Bid Express at <http://bidx.com>. Specimen proposals may be viewed and downloaded online at no cost at <http://mdot.ms.gov> or purchased online at <http://shop.mdot.ms.gov> at a cost of Ten Dollars (\$10.00) per proposal plus a small convenience fee. Cash or checks will not be accepted as payment.

Bid bond, signed or countersigned by a Mississippi Agent or Qualified Nonresident Agent, with Power of Attorney attached, a Cashier's check or Certified Check for five (5%) percent of bid, payable to STATE OF MISSISSIPPI, must accompany each proposal.

The attention of bidders is directed to the provisions of Subsection 102.07 pertaining to irregular proposals and rejection of bids.

BRAD WHITE
EXECUTIVE DIRECTOR

MISSISSIPPI DEPARTMENT OF TRANSPORTATION

SUPPLEMENT TO NOTICE TO BIDDERS NO. 1

DATE: 06/08/2021

SUBJECT: Governing Specifications

Change the web address at the end of the first paragraph to the following.

<https://shop.mdot.ms.gov/default.aspx?StoreIndex=1>

MISSISSIPPI DEPARTMENT OF TRANSPORTATION

SECTION 904 - NOTICE TO BIDDERS NO. 1

CODE: (IS)

DATE: 03/01/2017

SUBJECT: Governing Specifications

The current (2017) Edition of the Standard Specifications for Road and Bridge Construction adopted by the Mississippi Transportation Commission is made a part hereof fully and completely as if it were attached hereto, except where superseded by special provisions, or amended by revisions of the Specifications contained within this proposal. Copies of the specification book may be purchased from the MDOT Construction Division, or online at shopmdot/default.aspx?StoreIndex=1.

A reference in any contract document to controlling requirements in another portion of the contract documents shall be understood to apply equally to any revision or amendment thereof included in the contract.

In the event the plans or proposal contain references to the 2004 Edition of the Standard Specifications for Road and Bridge Construction, it is to be understood that such references shall mean the comparable provisions of the 2017 Edition of the Standard Specifications.

MISSISSIPPI DEPARTMENT OF TRANSPORTATION

SECTION 904 - NOTICE TO BIDDERS NO. 3

CODE: (SP)

DATE: 01/17/2017

SUBJECT: Final Clean-Up

Immediately prior to final inspection for release of maintenance, the Contractor shall pick up, load, transport and properly dispose of all litter from the entire highway right-of-way that is within the termini of the project.

Litter shall include, but not be limited to, solid wastes such a glass, paper products, tires, wood products, metal, synthetic materials and other miscellaneous debris.

Litter removal is considered incidental to other items of work and will not be measured for separate payment.

MISSISSIPPI DEPARTMENT OF TRANSPORTATION

SECTION 904 - NOTICE TO BIDDERS NO. 9

CODE: (IS)

DATE: 03/01/2017

SUBJECT: Federal Bridge Formula

Bidders are hereby advised that the latest revision of Federal Highway Administration Publication No. FHWA-HOP-06-105, **BRIDGE FORMULA WEIGHTS**, dated August 2006, is made a part of this contract when applicable.

Prior to the preconstruction conference, the Contractor shall advise the Engineer, in writing, what materials, if any, will be delivered to the jobsite via Interstate route(s).

Copies of the **BRIDGE FORMULA WEIGHTS** publication may be obtained by contacting:

Federal Highway Administration
400 7th Street, SW
Washington, DC 20590
(202) 366-2212

or

http://www.ops.fhwa.dot.gov/Freight/publications/brdg_frm_wgths/bridge_formula_all_rev.pdf

An on line **BRIDGE FORMULA WEIGHTS CALCULATOR** is available at

http://ops.fhwa.dot.gov/freight/sw/brdgcalc/calc_page.htm

MISSISSIPPI DEPARTMENT OF TRANSPORTATION

SECTION 904 - NOTICE TO BIDDERS NO. 32

CODE: (SP)

DATE: 03/06/2017

SUBJECT: Chip Seal Signs

The Contractor will be require to furnish, install and maintain the following chip seal signs during the life of the project. The cost of these signs shall be included in the cost of pay item 618-A, Maintenance of Traffic.

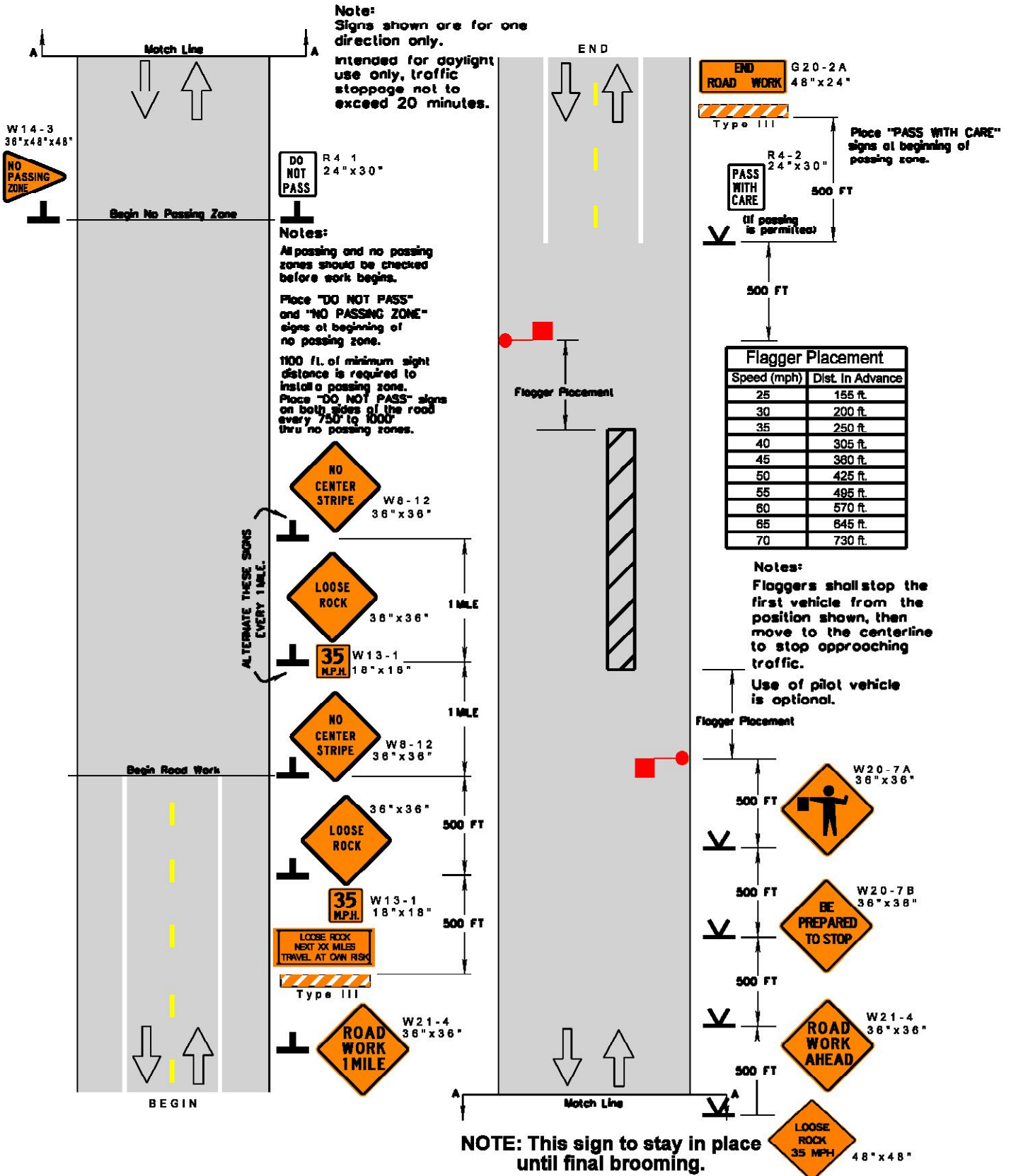

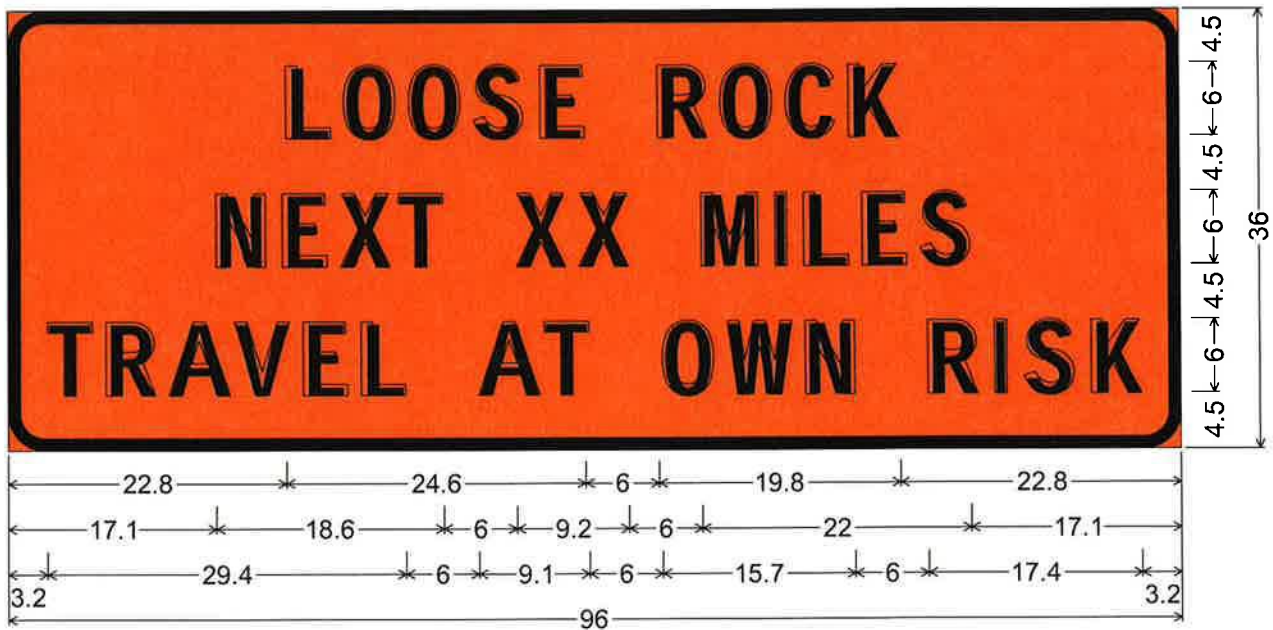

3.0" Radius, 1.0" Border, Black on Orange;

"LOOSE ROCK" D; "NEXT XX MILES" D; "TRAVEL AT OWN RISK" D;

Table of letter and object lefts.

L	O	O	S	E	R	O	C	K						
22.8	27.6	33.0	38.3	43.7	53.4	58.5	63.9	69.0						
N	E	X	T	X	X	M	I	L	E	S				
17.1	22.5	27.3	32.1	41.7	46.9	56.9	63.0	65.3	70.1	74.9				
T	R	A	V	E	L	A	T	O	W	N	R	I	S	K
3.2	8.0	13.2	18.6	24.2	29.0	38.6	44.0	53.7	59.0	65.4	75.4	80.9	83.2	88.6

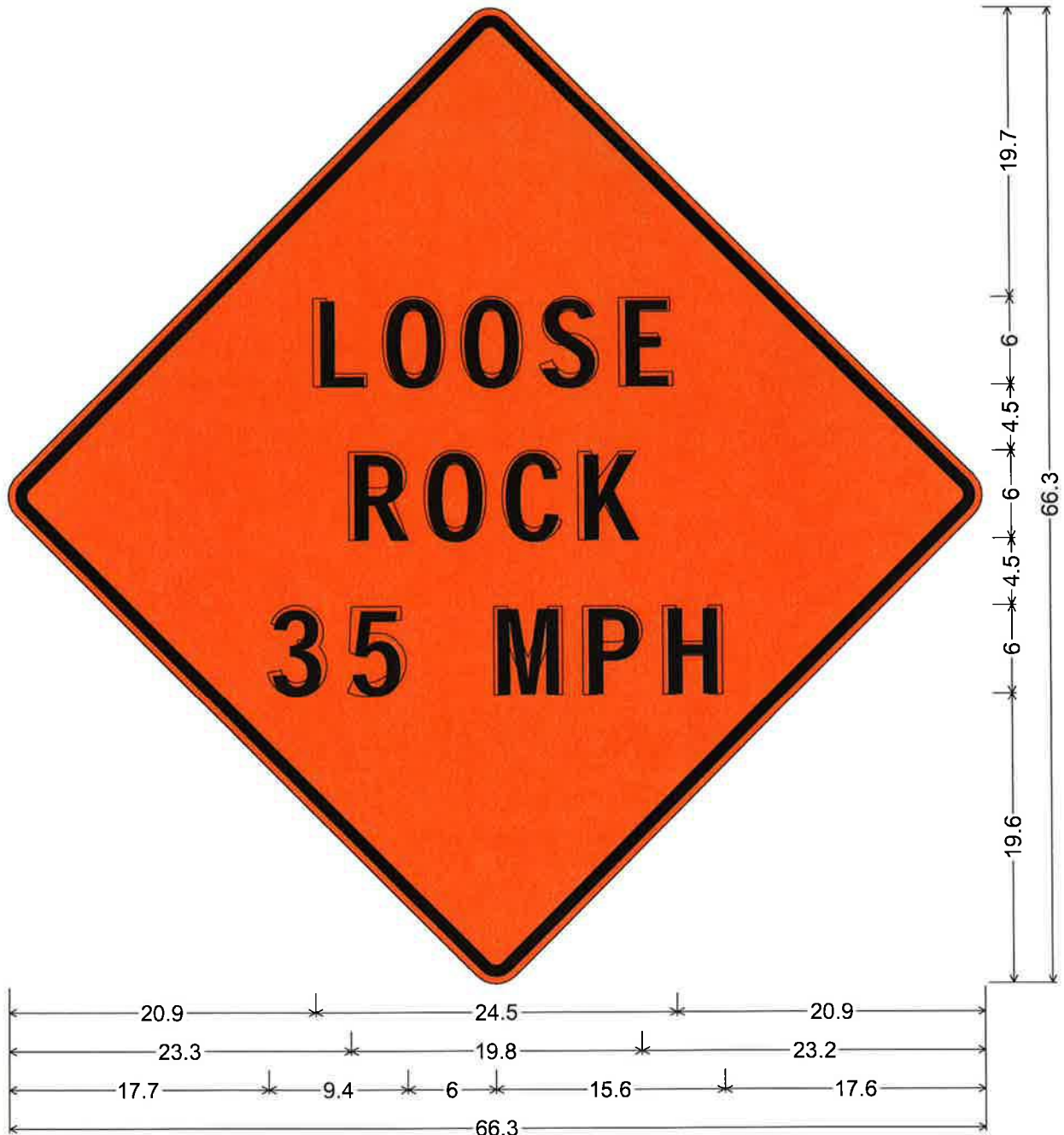

48.0" across sides 1.9" Radius, 0.8" Border, 0.5" Indent, Black on Orange;

"LOOSE" D; "ROCK" D; "35 MPH" D;

Table of letter and object lefts.

L	O	O	S	E
20.9	25.7	31.0	36.4	41.8
R	O	C	K	
23.3	28.4	33.8	38.9	
3	5	M	P	H
17.7	23.1	33.1	39.2	44.6

MISSISSIPPI DEPARTMENT OF TRANSPORTATION

SECTION 904 - NOTICE TO BIDDERS NO. 296

CODE: (SP)

DATE: 07/25/2017

SUBJECT: Reduced Speed Limit Signs

Bidders are advised that when the plans or contract documents require the speed limit on a project to be reduced, the Contractor shall begin work within 48 hours of installing the reduced speed limit signs. Should the Contractor not start work or have no plans to start work within 48 hours of installing the signs, the reduced speed limit signs shall be covered and existing speed limit signs uncovered.

MISSISSIPPI DEPARTMENT OF TRANSPORTATION

SECTION 904 - NOTICE TO BIDDERS NO. 445

CODE: (SP)

DATE: 10/10/2017

SUBJECT: Mississippi Agent or Qualified Nonresident Agent

Bidders are hereby advised of the requirements of Subsections 102.08, 103.05.2, and 107.14.2.1 of the *2017 Standard Specifications for Road and Bridge Construction* as it refers to bonding agents. Proposal guaranties, bonds, and liability insurance policies must be signed by a **Mississippi Agent or Qualified Nonresident Agent.**

MISSISSIPPI DEPARTMENT OF TRANSPORTATION

SECTION 904 - NOTICE TO BIDDERS NO. 516

CODE: (IS)

DATE: 11/28/2017

SUBJECT: Errata and Modifications to the 2017 Standard Specifications

<u>Page</u>	<u>Subsection</u>	<u>Change</u>
16	102.06	In the seventh full paragraph, change “Engineer” to “Director.”
33	105.05.1	In the sixth sentence, change “Contract Administration Engineer” to “Contract Administration Director.”
34	105.05.2.1	In subparagraph 2, change “SWPPP, ECP” to “SWPPP and the ECP”
35	105.05.2.2	In subparagraphs 2, add “ and” to the end of the sentence. In subparagraph 3, remove “, and” and add “.”.
90	109.04.2	In the last paragraph of subparagraph (a), place a period “.” at the end of the sentence.
93	109.04.2	In the last paragraph of subparagraph (g), place a period “.” at the end of the sentence. Also, in the first paragraph of subparagraph (h), place a period “.” at the end of the sentence.
97	109.07	Under ADJUSTMENT CODE, subparagraph (A1), change “HMA mixture” to “Asphalt mixtures.”
98	109.11	In the third sentence, change “Engineer” to “Director.”
219	308.04	In the last sentence of the last paragraph, change “Contractor’s decision” to “Engineer’s decision.”
300	405.02.5.9	In the first sentence of the second paragraph, change “Hot Mix Asphalt” to “Asphalt Mixtures.”
502	630.01.1	In the first paragraph, change “AASHTO” to “AASHTO’s LRFD”.
636	646.05	Change “each” to “per each” for the pay item units of payment.
640	656.02.6.2	In item 7), change “down stream” to “downstream”.
688	630.03.2	Change the subsection number from “630.03.2” to “680.03.2.”

725 702.08.3 In the second sentence of the first paragraph, change “hot-mix” to “asphalt.”

954 804.02.13.1.6 In the definition for “M” in the % Reduction formulas, change “paragraph 7.3” to “paragraph 5.3.”

MISSISSIPPI DEPARTMENT OF TRANSPORTATION

SECTION 904 - NOTICE TO BIDDERS NO. 1225

CODE: (SP)

DATE: 11/13/2018

SUBJECT: Early Notice to Proceed

Bidders are advised that if an early notice to proceed is allowed by the Department and the Contractor experiences problems or delays between the early notice to proceed date and the original notice to proceed date, this shall not be justification for any monetary compensation or an extension of contract time.

MISSISSIPPI DEPARTMENT OF TRANSPORTATION

SECTION 904 - NOTICE TO BIDDERS NO. 1226

CODE: (IS)

DATE: 11/16/2018

SUBJECT: Material Storage Under Bridges

Bidders are advised that Subsection 106.08 of the Standard Specifications allows the Contractor to store materials and equipment on portions of the right-of-way. However, the Contractor will not be allowed to store or stockpile materials under bridges without written permission from the Project Engineer. The Contractor shall submit a detailed request of all proposed materials to be stored under bridges to the Engineer a minimum of 14 calendar days prior to anticipated storage. This detail shall include, but not limited to, bridge location, material type, material quantity, and duration of storage. The Project Engineer and any other needed Division will review this information and determine whether to grant approval. The Contractor shall not store any material under any bridge without written approval from the Project Engineer.

MISSISSIPPI DEPARTMENT OF TRANSPORTATION

SECTION 904 - NOTICE TO BIDDERS NO. 1241

CODE: (IS)

DATE: 11/27/2018

SUBJECT: Fuel and Material Adjustments

Bidder's attention is brought to the last paragraph of Subsection 109.07 of the Standard Specifications which states that no fuel or material adjustment will be made after the completion of contract time. Any fuels consumed or materials incorporated into the work during the monthly estimate period falling wholly after the expiration of contract time will not be subject a fuel or material adjustment.

MISSISSIPPI DEPARTMENT OF TRANSPORTATION

SECTION 904 - NOTICE TO BIDDERS NO. 2206

CODE: (IS)

DATE: 01/14/2020

SUBJECT: MASH Compliant Devices

Bidders are hereby advised that compliance associated with the requirements of meeting either the National Cooperative Highway Research Program (NCHRP) Report 350 or the Manual for Assessing Safety Hardware (MASH) for installations of certain traffic control devices and permanent safety hardware devices (guardrails, guardrail terminals, permanent portable barriers, cast-in-place barriers, all other permanent longitudinal barriers, crash cushions, cable barriers, cable barrier terminals, bridge rails, bridge rail transitions, all other terminals, sign supports, and all other breakaway hardware) as listed throughout the Standard Specifications and/or the Standard Drawings, or both, is now replaced with the requirements of meeting the 2016 version of MASH after December 31, 2019. This change applies to new permanent installations and to full replacements of existing installations.

At the preconstruction conference or prior to starting any work on the project, the Contractor shall submit a letter stating that the traffic control devices and permanent safety hardware devices as outlined within the paragraph above that are to be used on the project are certified to meet MASH 2016.

When a MASH 2016-compliant device does not exist for the new permanent installations and/or full replacement installations of permanent safety hardware devices, as listed above, a MASH 2009-compliant or a NCHRP 350-compliant device may be proposed by the Contractor for the project. A written request for such instances must be submitted by the Contractor either at the preconstruction conference or prior to starting any work on the project. The Contractor shall submit the following items to the Project Engineer: (1) a detailed list of the proposed devices and locations thereof; and (2) certification letters indicating that the proposed devices are compliant with either MASH 2009 or NCHRP 350.

When a MASH 2016-compliant device does not exist for the temporary work zone traffic control devices (Category 1, Category 2, and Category 3 devices), a MASH 2009-compliant or a NCHRP 350-compliant device may be proposed by the Contractor for the project. Temporary work zone traffic control devices (Category 1, Category 2, and Category 3 devices) that are MASH 2009-compliant or NCHRP 350-compliant that have been in use prior to December 31, 2019, and that have a remaining service life may be proposed for use throughout their normal service life on the project by the Contractor. For either of these scenarios for temporary work zone traffic control devices, a written request must be submitted by the Contractor either at the preconstruction conference or prior to starting any work on the project. The Contractor shall submit the following items to the Project Engineer: (1) a detailed list of the proposed devices and locations thereof; and (2) certification letters indicating that the proposed devices are compliant with either MASH 2009 or NCHRP 350.

Work will only be allowed to proceed after the Department has granted written concurrence(s) with the proposed request(s) as listed above.

MISSISSIPPI DEPARTMENT OF TRANSPORTATION

SECTION 904 - NOTICE TO BIDDERS NO. 2273

CODE: (SP)

DATE: 02/12/2020

SUBJECT: Mississippi Special Fuel Tax Law

Bidder's attention is brought to the second paragraph of Subsection 107.02 of the Standard Specifications which states that all Contractors and Subcontractors must comply with all requirements contained in the Mississippi Special Fuel Tax Law, Section 27-55-501, *et seq.* Attached are two Fact Sheets provided by the Mississippi Department of Revenue (MDOR) with additional information.

Gasoline and Dyed Diesel Used for Non-Highway Purposes

Mississippi provides a reduced rate for gasoline and dyed diesel used for non-highway purposes. The reduced rates are 6.44 cents per gallon and 5.75 cents per gallon of gasoline or dyed diesel. These fuels are generally taxed at 18 cents per gallon if for on road use.

Gasoline Used for Non-Highway Purposes

You may be entitled to a refund of 11.56 cents per gallon (making this an equivalent to a tax rate of 6.44 cents per gallon) if you desire to purchase gasoline to be used off road. The gasoline must be used for agricultural, maritime, industrial, manufacturing, domestic or non-highway purposes only.

Examples of non-highway include gasoline used in boats, golf carts, machinery used for manufacturing or farm equipment used exclusively in plowing, planting or harvesting farm products.

Refund Gasoline User

The refund is based on the amount of gallons used. Before a refund is issued, you are required to...

1. Obtain a refund gasoline user's permit and a certificate for refund booklet from the Department of Revenue;
2. Have a storage tank marked "REFUND GASOLINE"; and,
3. Purchase the gasoline from someone who holds a refund gasoline dealer's permit.

No refund will be allowed for gasoline used in motor vehicles owned or operated by a government entity or used in Mississippi government contracts.

Refund Gasoline Dealer

You must obtain a refund gasoline dealer's permit from the Department of Revenue before selling refund gasoline. At no time should the gasoline be delivered to a tank that is not properly marked. The gasoline must be dyed a distinctive mahogany color at the time of delivery.

The Department of Revenue may waive the dye requirement if the dye may cause damage to the equipment. The refund gasoline user is required to obtain the waiver from the Department of Revenue.

Dyed Diesel Used for Non-Highway Purposes

Unlike gasoline, you are not required to apply for a refund if you desire to purchase dyed diesel to be used off road. Mississippi provides a reduced rate of 5.75 cents per gallon on dyed diesel used off road. Diesel used on road is subjected to 18 cents per gallon. Dyed diesel used in motor vehicles owned or operated by a government entity or used in Mississippi government contracts will be subjected to 18 cents per gallon.

Dyed Diesel Used on the Highway

Any person who purchases, receives, acquires or uses dyed diesel for highway use will be liable to pay 18 cents per gallon and subject to a penalty in the amount of \$1000.

Identifying Dyed Diesel

Storage facilities for dyed diesel must be plainly marked "NONHIGHWAY DIESEL FUEL" or "NONHIGHWAY KEROSENE". Retailers are also required to mark all pumps or dispensing equipment.



Special Fuel Used on Government Contracts

State and Local Government Contracts

Special fuel purchased, acquired or used in performing contracts with the State of Mississippi, counties, municipalities or any political subdivision is taxed at a rate of 18 cents per gallon. Special fuel includes but is not limited to the following:

- Dyed diesel fuel;
- Kerosene;
- Undyed diesel fuel; and,
- Fuel oil.

State and local government contracts include construction, reconstruction and maintenance or repairs of projects such as roads, bridges, water systems, sewer systems, buildings, drainage canals and recreational facilities. The Department of Revenue may require contractors to remit the excise tax directly to the state in lieu of paying the tax to a distributor.

Special Fuel Direct Pay Permit

Contractors that remit the excise tax to the state will be issued a Special Fuel Direct Pay Permit. This permit relieves the distributor from collecting the tax and requires the contractor to file a monthly special fuel return. The distributor should include the contractor’s permit number on all invoices that are related to tax-free sales.

The contractor is required to furnish a surety or cash bond guaranteeing the payment of the excise tax prior to receiving the Special Fuel Direct Pay Permit. The Department of Revenue may accept a contractors tax bond if the bond covers the excise tax levied on special fuel.

Special Fuel Distributors

If the contractor does not have a Special Fuel Direct Pay Permit, distributors are required to collect the 18 cents excise tax and remit the tax to the Department of Revenue. The additional 12.25 cents levied on special fuel (excluding undyed diesel) should be reported on schedules 5F and 5G of the special fuel return.

Environmental Protection Fee

Special fuel distributors are required to collect the environmental protection fee even if the contractor has a Special Fuel Direct Pay Permit. The fee is levied at 4/10^{ths} of a cent per gallon. The fee is suspended or reinstated when the trust fund has exceeded or fallen below the obligatory balance.

Penalties

Any person who knowingly and willfully purchases untaxed fuel for use in equipment utilized on a road or highway construction site in this state is guilty of a misdemeanor and, upon conviction, shall be fined not less than \$1,000 or more than \$100,000, or imprisoned in the county jail for not more than one year, or both.



MISSISSIPPI DEPARTMENT OF TRANSPORTATION

SUPPLEMENT TO NOTICE TO BIDDERS NO. 2654

DATE: **05/02/2020**

The goal is 3 percent for the Disadvantaged Business Enterprise. All Bidders are required to submit Form OCR-481 for all DBEs. Bidders are advised to check the bid tabulation link for this project on the MDOT website at:

https://mdot.ms.gov/portal/current_letting

Bid tabulations are usually posted by 3:00 pm on Letting Day.

MISSISSIPPI DEPARTMENT OF TRANSPORTATION

SECTION 904 - NOTICE TO BIDDERS NO. 2654

CODE: (SP)

DATE: 05/02/2020

SUBJECT: Disadvantaged Business Enterprises In Special Funded Projects

The Department has developed a Disadvantaged Business Enterprise Program that is applicable to this contract and is made a part thereof by reference, except approvals and concurrences by the Federal Highway Administration is not applicable to this contract since it is not financed in whole or in part with Federal Funds.

Copies of the program may be obtained from:

Office of Civil Rights
Mississippi Department of Transportation
P. O. Box 1850
Jackson, Mississippi 39215-1850

POLICY

It is the policy of the Mississippi Department of Transportation to provide a level playing field, to foster equal opportunity in all contracts, to improve the flexibility of the DBE Program, to reduce the burdens on small businesses, and to achieve that amount of participation that would be obtained in a non-discriminatory market place. In doing so, it is the policy of MDOT that there will be no discrimination in the award and performance of these contracts on the basis of race, color, sex, or national origin.

ASSURANCES THAT CONTRACTORS MUST TAKE:

MDOT will require that each contract which MDOT signs with a subrecipient or a Contractor, and each subcontract the Prime Contractor signs with a Subcontractor, includes the following assurances:

“The Contractor, subrecipient or Subcontractor shall not discriminate on the basis of race, color, sex or national origin in the performance of this contract. Failure by the Contractor to carry out these requirements is a material breach of this contract, which may result in the termination of this contract or such other remedy as MDOT deems appropriate.”

DEFINITIONS

For purposes of this provision the following definitions will apply:

"Disadvantaged Business" means a small business concern: (a) which is at least 51 percent owned by one or more socially and economically disadvantaged individual(s) or in the case of any publicly owned business, at least 51 percent of the stock of which is owned by one or more socially

and economically disadvantaged individual(s); and (b) whose management and daily business operations are controlled by one or more of the socially and economically disadvantaged individual(s) who own it. It is important to note that the business owners themselves must control the operations of the business. Absentee ownership or title ownership by an individual who does not take an active role in controlling the business is not consistent with eligibility as a DBE under 49 CFR Part 26.71.

CONTRACTOR'S OBLIGATION

The Contractor and all Subcontractors shall take all necessary and reasonable steps to ensure that DBE firms compete for and participate in the performance of a portion of the work in this contract and shall not discriminate on the basis of race, color, sex or national origin. Failure on the part of the Contractor to carry out the DBE requirements of this contract constitutes a breach of contract and after proper notification the Department may terminate the contract or take other appropriate action as determined by the Department.

When a contract has a zero percent (0%) DBE goal, the Contractor still has the responsibility to take all necessary and reasonable steps to ensure that DBE firms can compete for and participate in the performance of the work in the contract. In this case, all work performed by a certified DBE firm is considered to be a “race neutral” measure and the Department will receive DBE credit towards the overall State goals when the DBE firm is paid for their work. If the Prime Contractor is a certified DBE firm, the Department can receive DBE credit only for the work performed by the Prime Contractor’s work force or any work subcontracted to another DBE firm. Work performance by a non-DBE Subcontractor is not eligible for DBE credit.

CONTRACT GOAL

The goal for participation by DBEs is established for this contract in the attached Supplement. The Contractor shall exercise all necessary and reasonable steps to ensure that participation is equal to or exceeds the contract goal.

If the percentage of the contract that is proposed for DBEs is 1% or greater, shall be so stated on the last bid sheet of the proposal.

All Bidders shall submit to the Office of Civil Rights Form OCR-481, signed by the Prime Contractor and the DBE Subcontractors, no later than the 3rd business day after opening of the bids.

Form OCR-481 is available on the MDOT website at www.mdot.ms.gov under the Civil Rights tab, or by calling 601-359-7466.

The OCR-481 Form must contain the following information:

The name and address of each certified DBE Contractor/Supplier;

The Reference Number, percent of work to be completed by the DBE subcontractor and the dollar amount of each item. If a portion of an item is subcontracted, a breakdown of that item

including quantities and unit price must be attached, detailing what part of the item the DBE firm is to perform and who will perform the remainder of the item.

If the DBE Commitment shown on the last bid sheet of the proposal, does not equal or exceed the contract goal, the bidder must submit, to MDOT Contract Administration Division prior to bid opening, information to satisfy the Department that adequate good faith efforts have been made to meet the contract goal.

Failure of the lowest bidder to furnish acceptable proof of good faith efforts, submitted to MDOT Contract Administration Division prior to bid opening, shall be just cause for rejection of the proposal. Award may then be made to the next lowest responsive bidder or the **project** may be re-advertised.

GOOD FAITH EFFORTS

The following factors are illustrative of matters the Department will consider in judging whether or not the bidder has made adequate good faith effort to satisfy the contract goal.

- (1) Whether the bidder attended the pre-bid meeting that was scheduled by the Department to inform DBEs of subcontracting opportunities;
- (2) whether the bidder advertised in general circulation, trade association, and minority-focus media concerning the subcontracting opportunities;
- (3) whether the bidder provided written notice to a reasonable number of specific DBEs that their interest in the contract is being solicited;
- (4) whether the bidder followed up initial solicitations of interest by contacting DBEs to determine with certainty whether they were interested;
- (5) whether the bidder selected portions of the work to be performed by DBEs in order to increase the likelihood of meeting the contract goal;
- (6) whether the bidder provided interested DBEs with adequate information about the plans, specifications and requirements of the contract;
- (7) whether the bidder negotiated in good faith with interested DBEs and did not reject them as unqualified without sound reasons based on a thorough investigation of their capabilities; and
- (8) whether the bidder made efforts to assist interested DBEs in obtaining any required bonding or insurance.
- (9) whether the bidder has written notification to certified DBE Contractors soliciting subcontracting for items of work in the contract.
- (10) whether the bidder has a statement of why an agreement was not reached.

- (11) Proof of written notification to certified DBE Contractors by certified mail that their interest is solicited in subcontracting the work defaulted by the previous DBE or in subcontracting other items of work in the contract.

The bidder's execution of the signature portion of the proposal shall constitute execution of the following assurance:

The bidder hereby gives assurance that a good faith effort has been made to meet the contract goal for DBE participation for which this proposal is submitted.

DIRECTORY

A list of “Certified DBE Contractors” which have been certified as such by the Mississippi Department of Transportation and other Unified Certification Partners (UPC) can be found on the Mississippi Department of Transportation website at www.mdot.ms.gov. The DBE firm must be certified at the time the project is let and approved by MDOT to count towards meeting the DBE goal.

REPLACEMENT

If a DBE Subcontractor cannot perform satisfactorily, and this causes the OCR-481 commitment to fall below the contract goal, the Contractor shall take all necessary reasonable steps to replace the DBE with another certified DBE Subcontractor or submit information to satisfy the Mississippi Department of Transportation that adequate good faith efforts have been made to replace the DBE. The good faith efforts outlined previously in this document still apply. The replacement DBE must be a DBE who was on the Department's list of "Certified DBE Contractors" when the job was let, and who is still active All DBE replacements must be approved by the Department.

Under no circumstances shall the Prime or any Subcontractor perform the DBE's work (as shown on the OCR-481) without prior written approval from the Department. See "Sanctions" at the end of this document for penalties for performing DBE's work.

When a Contractor proposes to substitute/replace/terminate a DBE that was originally named on the OCR-481, the Contractor must obtain a release, in writing, from the named DBE explaining why the DBE Subcontractor cannot perform the work. A copy of the original DBE's release must be attached to the Contractor's written request to substitute/replace/terminate along with appropriate subcontract forms for the substitute/replacement/terminated Subcontractor, all of which must be submitted to the DBE Coordinator and approved, in advance, by MDOT.

PREBID MEETING

A pre-bid meeting will be held in the Commission Room on the 1st floor of the MDOT Administration Building in Jackson at 2:00 P.M. on the day preceding the date of the bid opening.

This meeting is to inform DBE firms of subcontracting and material supply opportunities. Attendance at this meeting is considered of prime importance in demonstrating good faith effort to meet the contract goal.

PARTICIPATION / DBE CREDIT

Participation shall be counted toward meeting the goal in this contract as follows:

- (1) If the Prime Contractor is a certified DBE firm, only the value of the work actually performed by the DBE Prime can be counted towards the project goal, along with any work subcontracted to a certified DBE firm.
- (2) If the Prime Contractor is not a DBE, the work subcontracted to a certified DBE Contractor will be counted toward the goal.
- (3) The Contractor may count toward the goal a portion of the total dollar value of a contract with a joint venture eligible under the standards of this provision equal to the percentage of the DBE partner in the joint venture. The joint venture must submit a Joint Venture Eligibility Form provided by the Mississippi Department of Transportation.
- (4) Expenditures to DBEs that perform a commercially useful function may be counted toward the goal. A business is considered to perform a commercially useful function when it is responsible for the execution of a distinct element of the work and carries out its responsibilities by actually performing, managing, and supervising the work involved.
- (5) The Contractor may count 100% of the expenditures for materials and supplies obtained from certified DBE suppliers and manufacturers that produce goods from raw materials or substantially alters them for resale provided the suppliers and manufacturers assume the actual and contractual responsibility for the provision of the materials and supplies. The Contractor may count 60 percent of the expenditures to suppliers that are not manufacturers, provided the supplier performs a commercially useful function in the supply process. Within 30 days after receipt of the materials, the Prime Contractor shall furnish to the DBE Coordinator invoices from the certified supplier to verify the DBE goal.
- (6) Any work that a certified DBE firm subcontracts or sub-subcontracts to a non-DBE firm will not count towards the DBE goal
- (7) Only the dollars actually paid to the DBE firm may be counted towards the DBE goal.

AWARD

Award of this contract to the low bidder will be contingent upon the following condition:

- (1) **All Bidders** must submit to the Office of Civil Rights for approval, Form OCR-481 (DBE Commitment) no later than the 3rd business day after opening of the bids, or submit information with the bid proposal to satisfy the Department and that adequate good faith

efforts have been made to meet the contract goal. For answers to questions regarding Form OCR-481, contact the MDOT Office of Civil Rights at (601) 359-7466.

- (2) Bidder must include OCR-485 information with their bid proposal listing all firms that submitted quotes for material supplies or items to be subcontracted. OCR-485 information must be signed and included with the bid proposal. If the OCR-485 information is not included as part of bid proposal, your bid will be deemed irregular.

Prior to the start of any work, the bidder must notify the Project Engineer, in writing, of the name of the designated "DBE Liaison Officer" for this project. This notification must be posted on the bulletin board at the project site.

DEFAULT

If the contract goal established by MDOT in this proposal is 1% or greater, it must be met to fulfill the terms of the contract. The Contractor may list DBE Subcontractors and items that exceed MDOT's contract goal, but should unforeseen problems arise that would prevent a DBE from completing its total commitment percentage, the Contractor will meet the terms of the contract as long as it meets or exceeds MDOT's Contract Goal. For additional information, refer to "Replacement" section of this Notice.

DBE REPORTS

- (1) OCR-481: Refer to "CONTRACT GOAL" section of this Notice to Bidders for information regarding this form.
- (2) OCR-482: At the conclusion of the project the Contractor will submit to the Project Engineer for verification of quantities and further handling Form OCR-482 whereby the Contractor certifies to the amounts of payments made to each Contractor/Supplier. The Project Engineer shall submit the completed Form OCR-482 to the DBE Coordinator (Office of Civil Rights). Final acceptance of the project is dependent upon Contract Administration Division's receipt of completed Form OCR-482 which they will receive from the Office of Civil Rights.
- (3) OCR-483: The Project Engineer/Inspector will complete Form OCR-483, the Commercially Useful Function (CUF) Performance Report, in accordance with MDOT S.O.P. No. OCR-03-05-02-483. Evaluations reported on this form are used to determine whether or not the DBE firm is performing a CUF. The Prime Contractor should take corrective action when the report contains any negative evaluations. DBE credit may be disallowed and/or other sanctions imposed if it is determined the DBE firm is not performing a CUF. This form should also be completed and returned to the DBE Coordinator (Office of Civil Rights).
- (4) OCR-484: Each month, the Prime Contractor will submit to the Project Engineer OCR-484 that certifies payments to all Subcontractors and shows all firms even if

the Prime Contractor has paid no monies to the firm during that estimate period (negative report). The Project Engineer will attach the form to the monthly estimate before forwarding to the Contract Administration Division for further processing. Failure of the Contractor to submit the OCR-484 will result in the estimate not being processed and paid.

- (5) OCR-485: Bidder must submit **signed form with bid proposal** of all firms that submitted quotes for material supplies or items to be subcontracted. If the OCR-485 information is not included as part of bid proposal, your bid will be deemed irregular.
- (6) OCR-487: Only used by Prime Contractors that are certified DBE firms. This form is used in determining the exact percentage of DBE credit for the specified project. **The low Bidder** should **return this form** to MDOT with the OCR-481 form, or can also be returned with the Permission to Subcontract Forms (CAD-720, CAD-725 and CAD-521).

DBE Forms, can be obtained from the Office of Civil Rights Division, MDOT Administration Building, 401 North West Street, Jackson, MS, or at www.mdot.ms.gov under the Civil Rights tab.

SANCTIONS

The Department has the option to enforce any of the following penalties for failure of the Prime Contractor to fulfill the DBE goal as stated on the OCR-481 form or any violations of the DBE program guidelines:

- (1) Disallow credit towards the DBE goal
- (2) Withhold progress estimate payments
- (3) Deduct from the final estimate or recover an amount equal to the unmet portion of the DBE goal which may include additional monetary penalties as outlined below based on the number of offenses and the severity of the violation as determined by MDOT.

Offense #1	10% of unmet portion of goal	or	\$5,000 lump sum payment	or	Both
Offense #2	20% of unmet portion of goal	or	\$10,000 lump sum payment	or	Both
Offense #3	40% of unmet portion of goal	or	\$20,000 lump sum payment	or	\$20,000 lump sum payment and debarment

- (4) Debar the Contractor involved from bidding on Mississippi Department of Transportation projects **for a period of up to 12 months after notification by certified email.**

MISSISSIPPI DEPARTMENT OF TRANSPORTATION

SECTION 904 - NOTICE TO BIDDERS NO. 2954

CODE: (IS)

DATE: 12/01/2020

SUBJECT: Reflective Sheeting for Signs

Bidders are hereby advised that the retroreflective sign sheeting used for signs on this project shall be as listed below and shall meet the requirements of Subsection 721.06.

Temporary Construction Signs

Temporary traffic control (orange) sign sheeting shall be a minimum Type IX Fluorescent Orange sheeting as shown in Special Provision 907-721.

Permanent Signs

Permanent signs, except signs on traffic signal poles/mast arms, shall be as follows:

- Brown background sheeting on guide signs shall be a minimum Type VIII sheeting,
- Green and blue background sheeting on guide signs shall be a minimum Type IX sheeting, and
- All white, yellow, red, fluorescent yellow, and fluorescent yellow/green sheeting shall be Type XI sheeting.

MISSISSIPPI DEPARTMENT OF TRANSPORTATION

SECTION 904 - NOTICE TO BIDDERS NO. 3318

CODE: (SP)

DATE: 04/29/2021

SUBJECT: DBE Pre-Bid Meeting

Due to the COVID-19 pandemic and the Department not allowing visitors in the Administration Building at this time, the DBE Pre-Bid Meeting referenced on Pages 4 & 5 of Notice to Bidders No. 2654 will be held by **video conference only**. The meeting will be held at 2:00 P.M. on the day preceding the date of the bid opening using Zoom video conferencing software. Anyone interested in participating can download Zoom and connect to the meeting at the below link.

<https://zoom.us/j/5548736403?pwd=SDh5S2hQSE5pNG5FOEkzR3NsUnBYQT09>

Password (if prompted): 272147

For those unable to participate via Zoom, the below teleconference number may be used instead.

1-888-227-7517

Conference Code: 404496

MISSISSIPPI DEPARTMENT OF TRANSPORTATION

| **SUPPLEMENT TO NOTICE TO BIDDERS NO. 3599**

| **DATE: 08/11/2021**

| After the last drawing on page 33, add the following.

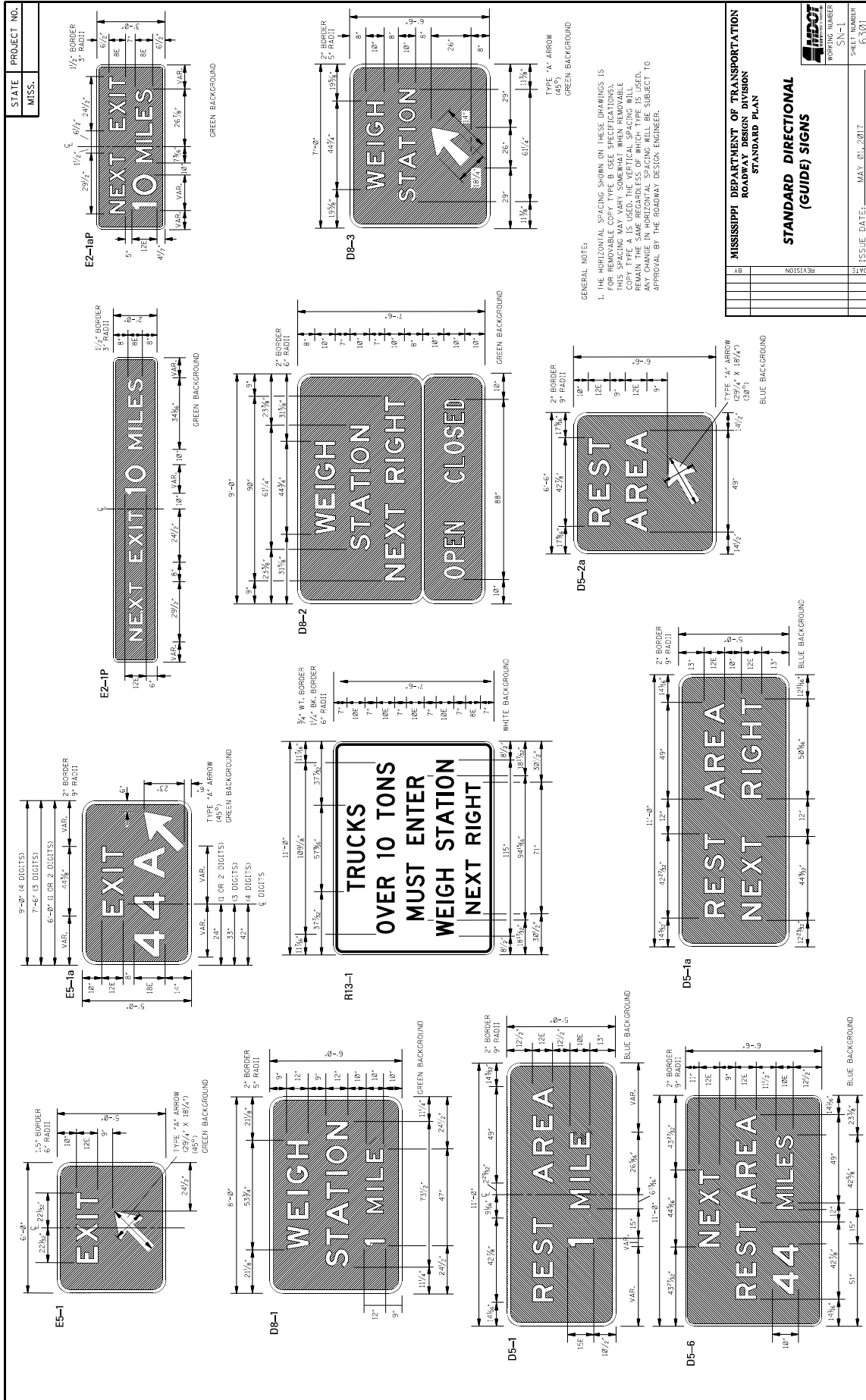

STATE	PROJECT NO.
MISS.	

GENERAL NOTES:

- U.S. AND MISSISSIPPI SHIELDS DO NOT HAVE AN OUTSIDE BORDER.
- INTERSTATE, U.S. AND MISSISSIPPI SHIELDS ARE TO BE USED ONLY ON GUIDE SIGNS. SEE OTHER DRAWINGS FOR SHIELDS TO BE USED INDEPENDENTLY AS ROUTE NUMBERS.
- ON INTERSTATE SHIELDS, THE LEGEND AND BACKGROUND SHALL BE REFLECTORIZED.
- ON U.S. AND MISSISSIPPI SHIELDS, THE BACKGROUND SHALL BE REFLECTORIZED.
- IN SOME CASES, NUMERALS CANNOT BE ACCOMMODATED WITHIN THE SHIELD. IN THESE SITUATIONS, THE STANDARD SERIES "D" NUMERALS MAY BE REDUCED TO SERIES "C" NUMERALS OR AS SMALLER HEIGHT COMMONLY AVAILABLE.

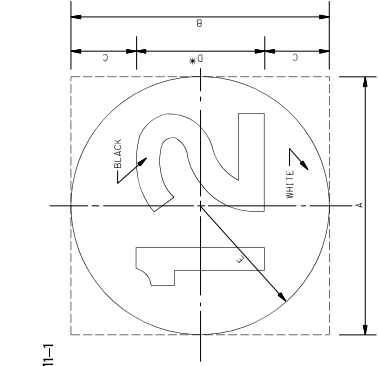

M1-1

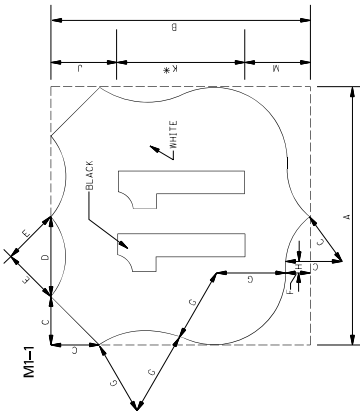

M1-1

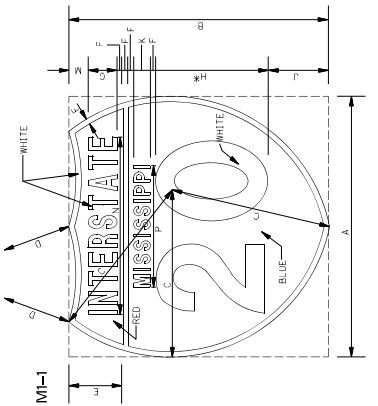

M1-1

18" NUMERALS	18" NUMERALS	24" NUMERALS	24" NUMERALS
2 DIGITS	3 DIGITS	2 DIGITS	3 DIGITS
A	2 1/2"	3 3/8"	4 1/2"
B	2 1/4"	2 3/4"	3 1/2"
C	1 5/8"	1 7/8"	2 1/2"
D	1 1/2"	1 3/4"	2 1/4"
E	1 1/4"	1 3/4"	2 1/4"
F	1 1/4"	1 3/4"	2 1/4"
G	1 1/4"	1 3/4"	2 1/4"
H	1 1/4"	1 3/4"	2 1/4"
I	1 1/4"	1 3/4"	2 1/4"
J	1 1/4"	1 3/4"	2 1/4"
K	1 1/4"	1 3/4"	2 1/4"
L	1 1/4"	1 3/4"	2 1/4"
M	1 1/4"	1 3/4"	2 1/4"
N	1 1/4"	1 3/4"	2 1/4"
O	1 1/4"	1 3/4"	2 1/4"
P	1 1/4"	1 3/4"	2 1/4"

18" NUMERALS	18" NUMERALS	24" NUMERALS	24" NUMERALS
2 DIGITS	3 DIGITS	2 DIGITS	3 DIGITS
A	2 1/2"	3 3/8"	4 1/2"
B	2 1/4"	2 3/4"	3 1/2"
C	1 5/8"	1 7/8"	2 1/2"
D	1 1/2"	1 3/4"	2 1/4"
E	1 1/4"	1 3/4"	2 1/4"
F	1 1/4"	1 3/4"	2 1/4"
G	1 1/4"	1 3/4"	2 1/4"
H	1 1/4"	1 3/4"	2 1/4"
I	1 1/4"	1 3/4"	2 1/4"
J	1 1/4"	1 3/4"	2 1/4"
K	1 1/4"	1 3/4"	2 1/4"
L	1 1/4"	1 3/4"	2 1/4"
M	1 1/4"	1 3/4"	2 1/4"
N	1 1/4"	1 3/4"	2 1/4"
O	1 1/4"	1 3/4"	2 1/4"
P	1 1/4"	1 3/4"	2 1/4"

	DIMENSIONS (INCHES)			
	A	B	C	D
12-DIGITS	24"	36"	36"	36"
12-DIGITS	36"	54"	54"	54"
12-DIGITS	48"	72"	72"	72"
12-DIGITS	60"	90"	90"	90"
12-DIGITS	72"	108"	108"	108"
12-DIGITS	84"	126"	126"	126"
12-DIGITS	96"	144"	144"	144"
12-DIGITS	108"	162"	162"	162"
12-DIGITS	120"	180"	180"	180"
12-DIGITS	132"	198"	198"	198"
12-DIGITS	144"	216"	216"	216"

- GENERAL NOTES:
- THESE SIGNS SHALL BE FABRICATED ON 0.063" THICK ALUMINUM (6061-T6) OR 0.063" THICK GALVANNEED STEEL. THE NUMERALS (6061-T6) SHALL BE REVERSED DIRECTIONAL SIGNS DESIGNATED ON PLANS. THESE SIGNS WILL NOT BE PAID FOR AS SEPARATE SIGNS BUT SHALL BE CONSIDERED AS PART OF THE MAJOR SIGNS TO WHICH THEY ARE AFFIXED.
 - LETTER SIZE: 12" SERIES "D"
 - COLOR: LEGEND - BLACK; BACKGROUND - HI-INTENSITY YELLOW

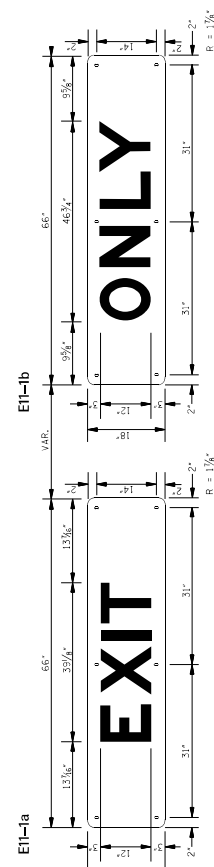

E11-1a

E11-1b

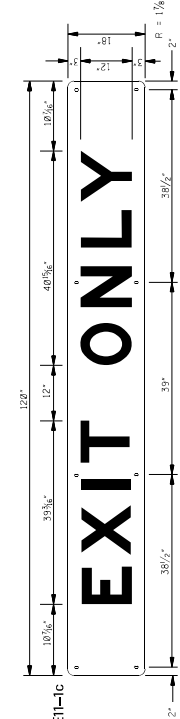

E11-1c

MISSISSIPPI DEPARTMENT OF TRANSPORTATION ROADWAY DESIGN DIVISION STANDARD PLAN	
ROUTE SHIELDS AND "EXIT ONLY" PANELS	
BY	REVISION
DATE	ISSUE DATE: MAY 01, 2012
	SHEET NUMBER SN-2
	SHEET NUMBER 63/62

SIGN NUMBER	R1-1		R1-2		R2-1		R2-4g		R3-1		R3-2		R3-4		R3-5		R4-3	
	ALUMINUM (6061-T6) SIGN BLANK THICKNESS	0.125"	0.080"	0.100"	0.080"	0.125"	0.100"	0.080"	0.125"	0.100"	0.080"	0.100"	0.080"	0.100"	0.080"	0.100"	0.080"	0.125"
LETTERS & NUMERICAL SERIES	12" SERIES 'C' 18" SERIES 'C' 3" SERIES 'C'	3" SERIES 'C' 5" SERIES 'C' 8" SERIES 'C' 12" SERIES 'C'	6" RED 8" RED 12" RED 18" RED	4" SERIES 'E' 6" SERIES 'E' 8" SERIES 'E' 10" SERIES 'E' 14" SERIES 'E'	4" SERIES 'E' 6" SERIES 'E' 8" SERIES 'E' 10" SERIES 'E' 14" SERIES 'E'	6" SERIES 'E' 8" SERIES 'E' 10" SERIES 'E' 14" SERIES 'E'	8" SERIES 'E' 10" SERIES 'E' 14" SERIES 'E'	8" SERIES 'E' 10" SERIES 'E' 14" SERIES 'E'	8" SERIES 'E' 10" SERIES 'E' 14" SERIES 'E'	8" SERIES 'E' 10" SERIES 'E' 14" SERIES 'E'	8" SERIES 'E' 10" SERIES 'E' 14" SERIES 'E'	8" SERIES 'E' 10" SERIES 'E' 14" SERIES 'E'	8" SERIES 'E' 10" SERIES 'E' 14" SERIES 'E'	8" SERIES 'E' 10" SERIES 'E' 14" SERIES 'E'	8" SERIES 'E' 10" SERIES 'E' 14" SERIES 'E'	8" SERIES 'E' 10" SERIES 'E' 14" SERIES 'E'	8" SERIES 'E' 10" SERIES 'E' 14" SERIES 'E'	8" SERIES 'E' 10" SERIES 'E' 14" SERIES 'E'
WIDTH OF BORDER	OUTSIDE 1/2" WHITE	OUTSIDE 1/2" WHITE	OUTSIDE 1/2" WHITE	OUTSIDE 1/2" WHITE	OUTSIDE 1/2" WHITE	OUTSIDE 1/2" WHITE	OUTSIDE 1/2" WHITE	OUTSIDE 1/2" WHITE	OUTSIDE 1/2" WHITE	OUTSIDE 1/2" WHITE	OUTSIDE 1/2" WHITE	OUTSIDE 1/2" WHITE	OUTSIDE 1/2" WHITE	OUTSIDE 1/2" WHITE	OUTSIDE 1/2" WHITE	OUTSIDE 1/2" WHITE	OUTSIDE 1/2" WHITE	OUTSIDE 1/2" WHITE
SIZE (WIDTH X HEIGHT)	36" OCTAGON	48" OCTAGON	36" TRIANGLE	36" TRIANGLE	36" TRIANGLE	36" TRIANGLE	36" TRIANGLE	36" TRIANGLE	36" TRIANGLE	36" TRIANGLE	36" TRIANGLE	36" TRIANGLE	36" TRIANGLE	36" TRIANGLE	36" TRIANGLE	36" TRIANGLE	36" TRIANGLE	36" TRIANGLE
COLORS	WHITE RED	WHITE RED	RED WHITE	RED WHITE	RED WHITE	RED WHITE	RED WHITE	RED WHITE	RED WHITE	RED WHITE	RED WHITE	RED WHITE	RED WHITE	RED WHITE	RED WHITE	RED WHITE	RED WHITE	RED WHITE
REFLECTORIZATION	ALL	ALL	ALL	ALL	ALL	ALL	ALL	ALL	ALL	ALL	ALL	ALL	ALL	ALL	ALL	ALL	ALL	ALL
NUMBER OF POSTS	1	1	1	1	1	1	1	1	1	1	1	1	1	1	1	1	1	1
TURNING POINTS TO BE PUNCHED (% DIA.)	18" (VERT. CENTER)	18" (VERT. CENTER)	12" (FROM CENTER)	12" (VERT. CENTER)	12" (VERT. CENTER)	12" (VERT. CENTER)	12" (VERT. CENTER)	12" (VERT. CENTER)	12" (VERT. CENTER)	12" (VERT. CENTER)	12" (VERT. CENTER)	12" (VERT. CENTER)	12" (VERT. CENTER)	12" (VERT. CENTER)	12" (VERT. CENTER)	12" (VERT. CENTER)	12" (VERT. CENTER)	12" (VERT. CENTER)
PUNCHING DISTANCE FROM MOUNTING SURFACE	94.38"	94.38"	31.27"	31.27"	31.27"	31.27"	31.27"	31.27"	31.27"	31.27"	31.27"	31.27"	31.27"	31.27"	31.27"	31.27"	31.27"	31.27"
PUNCHING DISTANCE FROM TOP EDGE	31.27"	31.27"	31.27"	31.27"	31.27"	31.27"	31.27"	31.27"	31.27"	31.27"	31.27"	31.27"	31.27"	31.27"	31.27"	31.27"	31.27"	31.27"
ALUMINUM (6061-T6) SIGN BLANK THICKNESS	0.080"	0.125"	0.080"	0.080"	0.100"	0.125"	0.100"	0.100"	0.080"	0.080"	0.080"	0.080"	0.080"	0.080"	0.080"	0.080"	0.125"	0.125"
LETTERS & NUMERICAL SERIES	R1-1/2	R1-1/2	R1-1/2	R1-1/2	R1-1/2	R1-1/2	R1-1/2	R1-1/2	R1-1/2	R1-1/2	R1-1/2	R1-1/2	R1-1/2	R1-1/2	R1-1/2	R1-1/2	R1-1/2	R1-1/2
WIDTH OF BORDER	INSIDE 3/8" BLACK 5/8" WHITE	INSIDE 3/8" BLACK 5/8" WHITE	INSIDE 3/8" BLACK 5/8" WHITE	INSIDE 3/8" BLACK 5/8" WHITE	INSIDE 3/8" BLACK 5/8" WHITE	INSIDE 3/8" BLACK 5/8" WHITE	INSIDE 3/8" BLACK 5/8" WHITE	INSIDE 3/8" BLACK 5/8" WHITE	INSIDE 3/8" BLACK 5/8" WHITE	INSIDE 3/8" BLACK 5/8" WHITE	INSIDE 3/8" BLACK 5/8" WHITE	INSIDE 3/8" BLACK 5/8" WHITE	INSIDE 3/8" BLACK 5/8" WHITE	INSIDE 3/8" BLACK 5/8" WHITE	INSIDE 3/8" BLACK 5/8" WHITE	INSIDE 3/8" BLACK 5/8" WHITE	INSIDE 3/8" BLACK 5/8" WHITE	INSIDE 3/8" BLACK 5/8" WHITE
SIZE (WIDTH X HEIGHT)	24" X 30"	36" X 48"	30" X 24"	36" X 36"	42" X 30"	48" X 48"	48" X 48"	48" X 48"	48" X 48"	48" X 48"	48" X 48"	48" X 48"	48" X 48"	48" X 48"	48" X 48"	48" X 48"	48" X 48"	48" X 48"
COLORS	BLACK WHITE	BLACK WHITE	BLACK WHITE	BLACK WHITE	BLACK WHITE	BLACK WHITE	BLACK WHITE	BLACK WHITE	BLACK WHITE	BLACK WHITE	BLACK WHITE	BLACK WHITE	BLACK WHITE	BLACK WHITE	BLACK WHITE	BLACK WHITE	BLACK WHITE	BLACK WHITE
REFLECTORIZATION	BACKGROUND	BACKGROUND	BACKGROUND	BACKGROUND	BACKGROUND	BACKGROUND	BACKGROUND	BACKGROUND	BACKGROUND	BACKGROUND	BACKGROUND	BACKGROUND	BACKGROUND	BACKGROUND	BACKGROUND	BACKGROUND	BACKGROUND	BACKGROUND
NUMBER OF POSTS	1	1	1	1	1	1	1	1	1	1	1	1	1	1	1	1	1	1
TURNING POINTS TO BE PUNCHED (% DIA.)	12" (VERT. CENTER)	12" (VERT. CENTER)	15" (FROM CENTER)	15" (VERT. CENTER)	15" (VERT. CENTER)	15" (VERT. CENTER)	15" (VERT. CENTER)	15" (VERT. CENTER)	15" (VERT. CENTER)	15" (VERT. CENTER)	15" (VERT. CENTER)	15" (VERT. CENTER)	15" (VERT. CENTER)	15" (VERT. CENTER)	15" (VERT. CENTER)	15" (VERT. CENTER)	15" (VERT. CENTER)	15" (VERT. CENTER)
PUNCHING DISTANCE FROM MOUNTING SURFACE	94.38"	94.38"	31.27"	31.27"	31.27"	31.27"	31.27"	31.27"	31.27"	31.27"	31.27"	31.27"	31.27"	31.27"	31.27"	31.27"	31.27"	31.27"
PUNCHING DISTANCE FROM TOP EDGE	31.27"	31.27"	31.27"	31.27"	31.27"	31.27"	31.27"	31.27"	31.27"	31.27"	31.27"	31.27"	31.27"	31.27"	31.27"	31.27"	31.27"	31.27"
ALUMINUM (6061-T6) SIGN BLANK THICKNESS	0.080"	0.125"	0.080"	0.100"	0.125"	0.100"	0.100"	0.100"	0.080"	0.080"	0.080"	0.080"	0.080"	0.080"	0.080"	0.080"	0.125"	0.125"

MISSISSIPPI DEPARTMENT OF TRANSPORTATION
ROADWAY DESIGN DIVISION
STANDARD PLAN

**STANDARD
ROADSIDE SIGNS**

ISSUE DATE: MAY 01, 2017
SHEET NUMBER SN-5A
WORKING NUMBER 62064

GENERAL NOTES

1. THE QUANTITIES LISTED ON THE SUMMARY OF QUANTITIES SHEET FOR THE SIGNS SHOWN ON THIS SHEET WILL BE USED AS THE BASIS FOR FINAL PAYMENT, EXCEPT WHERE SIGNS ARE MODIFIED FROM THAT SHOWN.
2. THE SPEED LIMITS REQUIRED ON SIGNS R2-1 AND R2-4g WILL BE SHOWN ON INDIVIDUAL PLAN SHEETS.

STATE MISS.	PROJECT NO.		
----------------	-------------	--	--

ROADSIDE SIGN IN RURAL AREA

12 FT. MIN.

7 FT. MIN.

ROADSIDE SIGN IN BUSINESS, COMMERCIAL, OR RESIDENTIAL AREA

7 FT. MIN.

7 FT. MIN.

* 2 FT. MIN.

WARNING SIGN WITH ADVISORY SPEED PLAQUE IN RURAL AREA

12 FT. MIN.

7 FT. MIN.

5 FT. MIN.

ROADSIDE SIGN IN RURAL AREA

6 FT. MIN.

SHOULDER WIDER THAN 6 FT.

ROADSIDE ASSEMBLY IN RURAL AREA

12 FT. MIN.

7 FT. MIN.

45

18

INTERSTATE OR FREEWAY SIGN WITH SECONDARY SIGN

12 FT. MIN.

7 FT. MIN.

5 FT. MIN.

6 FT. MIN.

SHOULDER

OVERHEAD SIGN

17 FT. MIN.

6 FT. MIN.

SHOULDER

SIGNS IN ISLANDS OR BEHIND CURB USING U-POSTS OR PIPE POSTS

2'-0" MINIMUM *
4'-0" RECOMMENDED

2'-2" MINIMUM *
4'-0" RECOMMENDED

6 FT.

6 FT.

1 FT. X 1 FT. HOLE IN CONCRETE ISLAND FOR BREAK AWAY S'UB OR CHANNEL POST

SIGN ON NOSE OF MEDIAN

7 FT. MIN.

4 FT. MIN.

PLAN

ELEVATION

GENERAL NOTES:

- SEE SECTION 2A-19 OF THE MUTCD FOR REDUCED LATERAL OFFSET DISTANCES THAT MAY BE USED IN AREAS WHERE LATERAL OFFSETS ARE LIMITED, AND IN BUSINESS, COMMERCIAL, OR RESIDENTIAL AREAS WHERE SIDEWALK WIDTH IS LIMITED OR WHERE EXISTING POLES ARE CLOSE TO THE CURB.
- LOCATED OUTSIDE THE CLEAR ZONE UNLESS PLACED ON A BREAKAWAY OR YIELDING SUPPORT.

MISSISSIPPI DEPARTMENT OF TRANSPORTATION
ROADWAY DESIGN DIVISION
STANDARD PLAN

**STANDARD SIGN
ROADSIDE SIGN
ASSEMBLY AND
INSTALLATION**

DATE	REVISION

ISSUE DATE: MAY 01, 2017
SHEET NUMBER: 6306
WORKING NUMBER: SN-4

MISSISSIPPI DEPARTMENT OF TRANSPORTATION
ROADWAY DESIGN DIVISION
STANDARD PLAN

**STANDARD SIGN
ROADSIDE SIGN
ASSEMBLY AND
INSTALLATION**

ISSUE DATE: MAY 01, 2017
SHEET NUMBER: 6306
WORKING NUMBER: SN-4

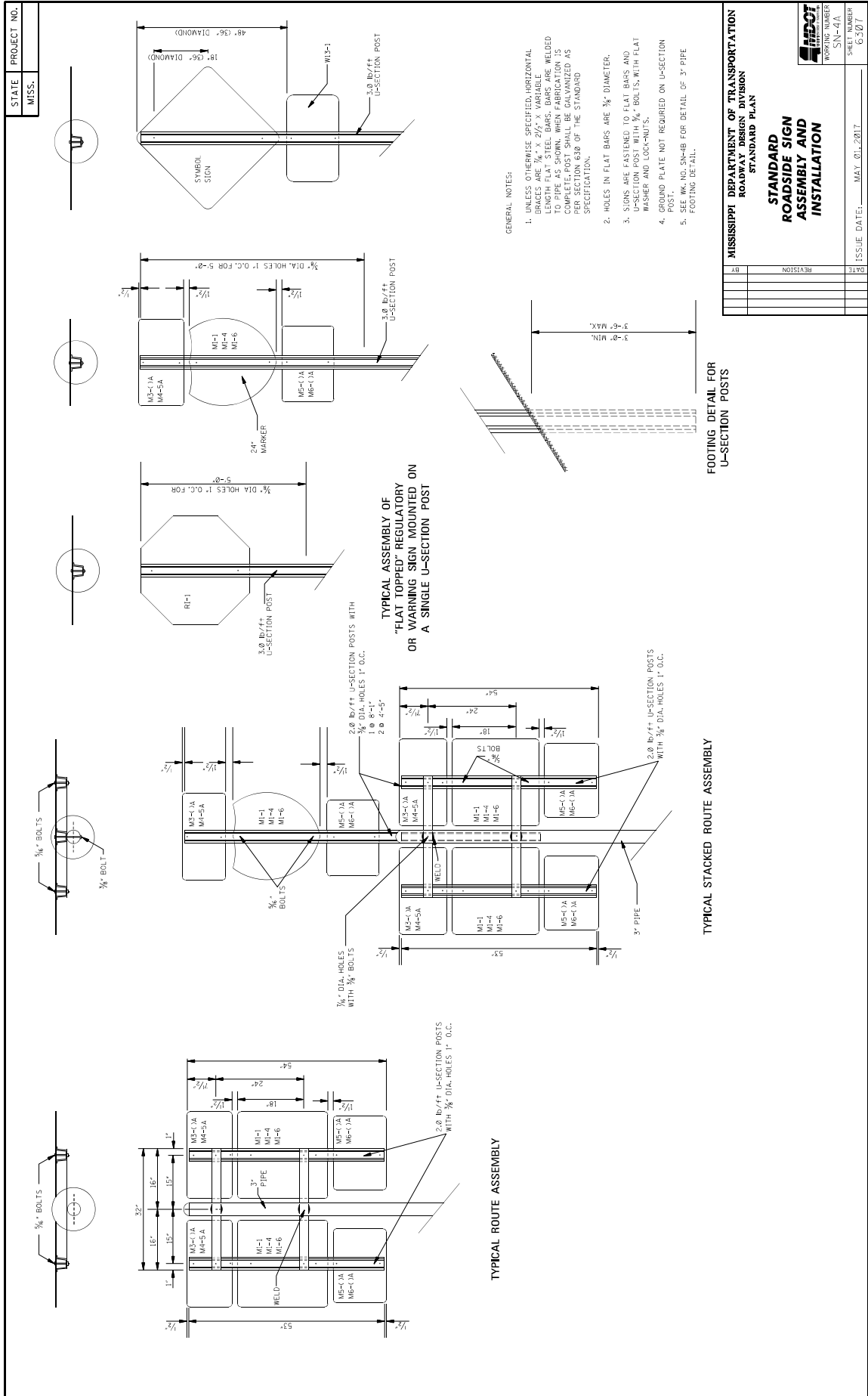

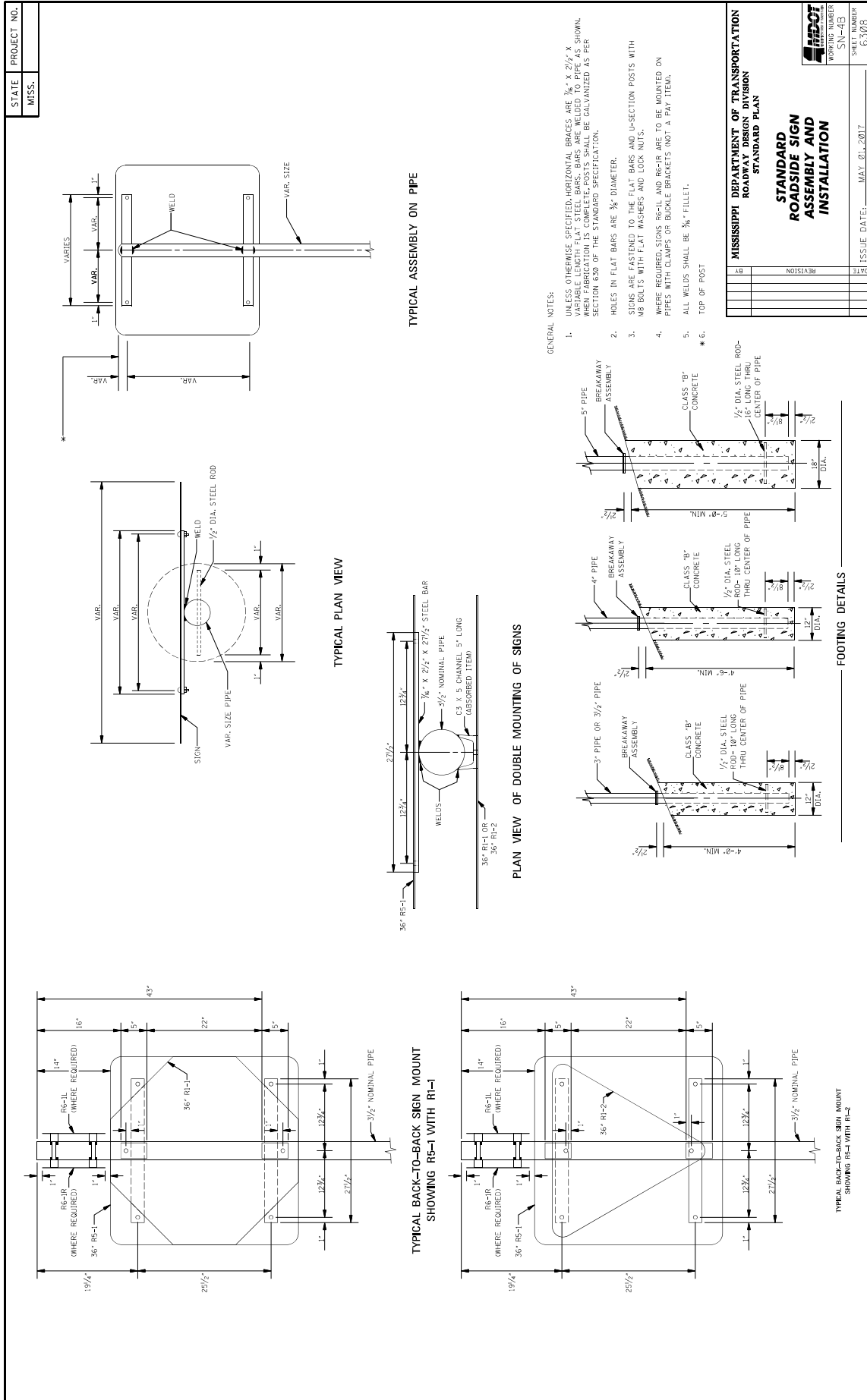

**MISSISSIPPI DEPARTMENT OF TRANSPORTATION
ROADWAY DESIGN DIVISION
STANDARD PLAN**

**STANDARD
ROADSIDE SIGN
ASSEMBLY AND
INSTALLATION**

WORKING NUMBER
SN-413

SHEET NUMBER
62/68

ISSUE DATE: MAY 01, 2017

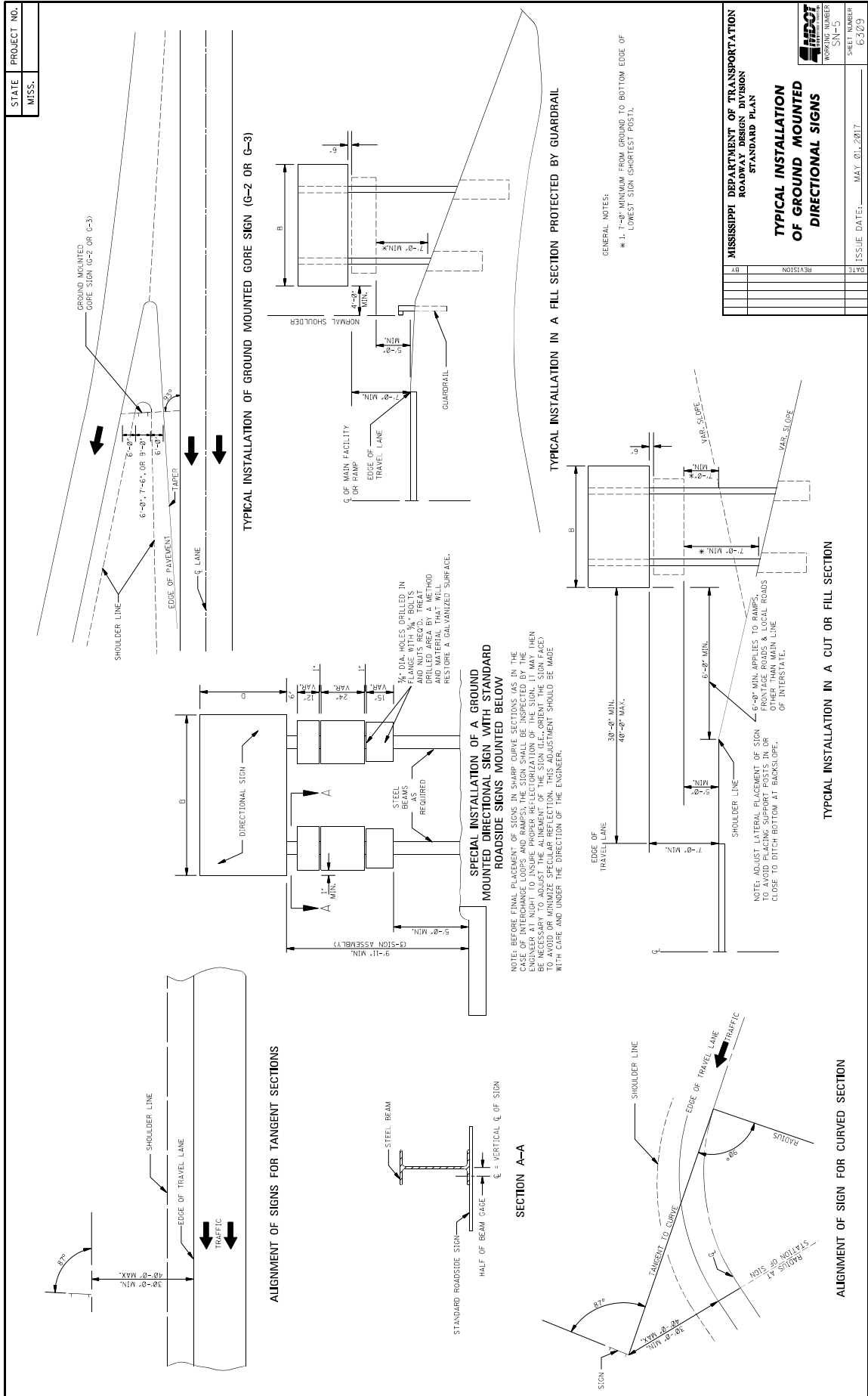

STATE PROJECT NO.
MISS.

GENERAL NOTES FOR WORKING SHEETS SN-6, SN-6A AND SN-6B:

- FOUNDING**
ALL FOOTINGS SHALL BE CLASS 'B' CONCRETE. POST STUBS SHALL BE SET IN CONCRETE FOOTING AT REQUIRED GRADE AND ALLOWMENT WITH CARE SO THAT MINIMUM SHIMMING WILL BE REQUIRED.
- BASE CONNECTION PROCEDURE**
ASSEMBLE POST TO STUB WITH BOLTS AND WITH A FLAT WASHER ON EACH BOLT BETWEEN PLATES. SHIM AS REQUIRED TO PLUMB POST. TIGHTEN ALL BOLTS THE MAXIMUM POSSIBLE WITH A 12" TO 15" WRENCH TO BED WASHERS AND STUBS AND TO CLEAR BOLT HEADS. THEN LOOSEN EACH BOLT TO CLEAR BOLT HEADS. REMOVE WASHERS AND STUBS FROM POST. THEN TIGHTEN EACH BOLT IN BASE CONNECTIONS SHALL BE TIGHTENED TO TORQUE AS SHOWN BY TABLE ON SN-6A. DO NOT OVER TIGHTEN.
- POST LENGTH**
ALL POST LENGTHS SHALL BE VERIFIED AND APPROVED BY THE ENGINEER PRIOR TO FABRICATION. WHERE FIELD CONDITIONS REQUIRE THE POST LENGTH TO VARY MORE THAN 12", IT MAY BE NECESSARY TO CHANGE THE SIZE OR NUMBER OF POSTS. SUCH DETERMINATION WILL BE MADE BY THE ROADWAY DESIGN ENGINEER. ANY CHANGE OF SIZE OR NUMBER OF POSTS SHALL NOT BE JUSTIFICATION FOR ANY CONTRACT PRICE ADJUSTMENTS.
- FABRICATOR NOTE**
IMPORTANT - ALL FRICTION FUSE BOLTS SHALL BE TIGHTENED IN SHOP BY A METHOD APPROVED BY THE ROADWAY DESIGN ENGINEER. TIGHTENING SHALL BE TO SUCH A DEGREE AS TO PROVIDE THE MINIMUM TENSION IN EACH BOLT WHEN ALL BOLTS ARE TIGHT, AS SHOWN BY TABLE SN-6A.
- ALL HOLES IN FUSE PLATES AND HINGE PLATES SHALL BE DRILLED.
- ALL PLATE CUTS SHALL PREFERABLY BE SAW CUTS. FLAME CUTTING WILL BE PERMITTED PROVIDED ALL EDGES ARE GRINDING. METAL PROJECTING BEYOND THE PLANE OF THE PLATE FACE WILL NOT BE ACCEPTABLE.
- WELDING FOR STEEL SIGN SUPPORTS**
WELDING SHALL BE PERFORMED IN SHOP BY ELECTRIC ARC PROCESS.
- MATERIAL SPECIFICATIONS**
THE MATERIALS USED IN THE CONSTRUCTION OF THE GROUND MOUNTED SIGN SUPPORT STRUCTURES, AS LISTED BELOW SHALL CONFORM WITH THE REQUIREMENTS OF THE DESIGNATED ASTM SPECIFICATION. ALL OTHER MATERIALS, FABRICATION AND ERECTION SHALL BE IN ACCORDANCE WITH THE REQUIREMENTS OF THE SPECIFICATIONS, EXCEPT AS OTHERWISE NOTED ON THE PLANS.

DESCRIPTION	MATERIALS PER ASTM SPECIFICATION	GALVANIZE PER ASTM DESIGNATION
POSTS OF STEEL PIPE	A 53 (GRADE 48) (2)	A 153
BASE CONNECTION PLATES FOR PIPES	A 36	A 123
POSTS OF STEEL W-, B- AND T BEAMS INCLUDING BASE CONNECTION, FUSE AND HINGE PLATES, ANGLES AND FLAT BARS USED IN FABRICATION AND ERECTION OF SIGN SUPPORTS	A 588 OR A 572 GRADE 58	A 123
HIGH STRENGTH BOLTS, NUTS AND WASHERS OTHER THAN HIGH STRENGTH (3)	A 36	A 123
	A 307 (GRADE 24)	A 153

- ALL STEEL SHALL BE GALVANIZED AFTER FABRICATION EXCEPT AS NOTED ON THE PLANS.
- PIPES MAY BE WELDED OR SEAMLESS.
- BOLTS, WASHERS, AND NUTS USED FOR FASTENING ALUMINUM SIGN SHEETS AND PANELS SHALL BE ALUMINUM AS PER FOLLOWING TABLE.

DESCRIPTION	ASTM DESIGNATION	ALLOY
BOLTS AND WASHERS	B 228	2024-T4
PANEL BOLT NUTS	B 211	6063-T6
STOP NUTS	B 211	2017-T4

MISSISSIPPI DEPARTMENT OF TRANSPORTATION
ROADWAY DESIGN DIVISION
STANDARD PLAN

**BREAKAWAY
SIGN SUPPORTS**

WORKING NUMBER: SN-6
SHEET NUMBER: 6310
ISSUE DATE: MAY 01, 2017

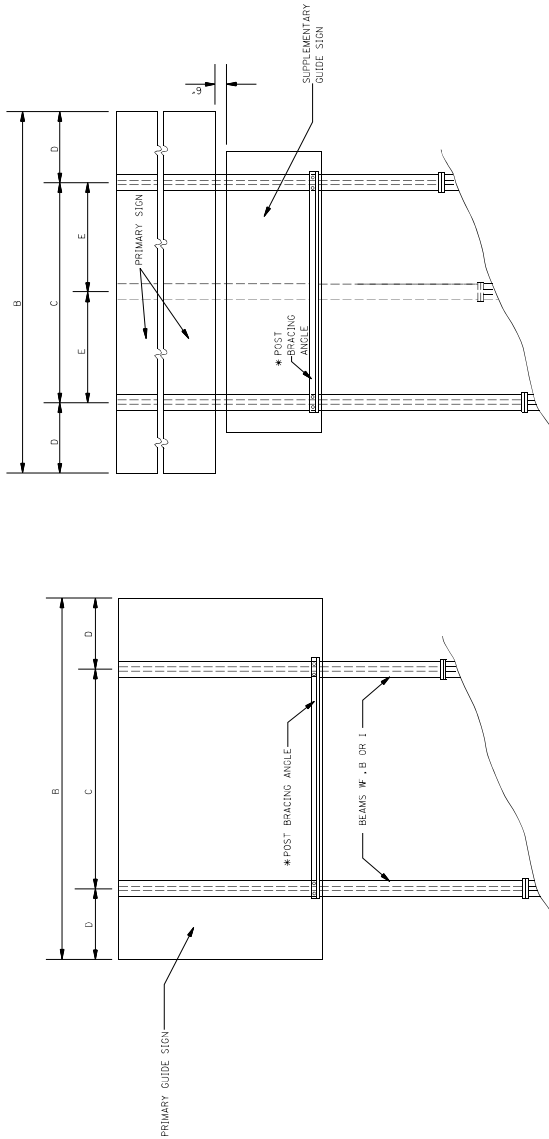

TYPICAL 2-POST INSTALLATION WITHOUT EXIT SIGN

TYPICAL 2 OR 3 POST INSTALLATION WITH SUPPLEMENTARY GUIDE SIGN AND POST BRACING ANGLE LOCATION

* NOTE: PLACE POST BRACING ANGLE AT BOTTOM OF PRIMARY OR SUPPLEMENTARY SIGN WHICHEVER IS LOWER. (SEE 'END ELEVATION OF POST AND FOOTING' ON SN-6A.)

2 POST		3 POST	
POST ELEVATION	POST SPACING	POST ELEVATION	POST SPACING
4'-0"	15'-0"	4'-0"	15'-0"
4'-6"	15'-6"	4'-6"	15'-6"
5'-0"	16'-0"	5'-0"	16'-0"
5'-6"	16'-6"	5'-6"	16'-6"
6'-0"	17'-0"	6'-0"	17'-0"
6'-6"	17'-6"	6'-6"	17'-6"
7'-0"	18'-0"	7'-0"	18'-0"
7'-6"	18'-6"	7'-6"	18'-6"
8'-0"	19'-0"	8'-0"	19'-0"
8'-6"	19'-6"	8'-6"	19'-6"
9'-0"	20'-0"	9'-0"	20'-0"
9'-6"	20'-6"	9'-6"	20'-6"
10'-0"	21'-0"	10'-0"	21'-0"
10'-6"	21'-6"	10'-6"	21'-6"
11'-0"	22'-0"	11'-0"	22'-0"
11'-6"	22'-6"	11'-6"	22'-6"
12'-0"	23'-0"	12'-0"	23'-0"
12'-6"	23'-6"	12'-6"	23'-6"
13'-0"	24'-0"	13'-0"	24'-0"
13'-6"	24'-6"	13'-6"	24'-6"
14'-0"	25'-0"	14'-0"	25'-0"
14'-6"	25'-6"	14'-6"	25'-6"
15'-0"	26'-0"	15'-0"	26'-0"
15'-6"	26'-6"	15'-6"	26'-6"
16'-0"	27'-0"	16'-0"	27'-0"
16'-6"	27'-6"	16'-6"	27'-6"
17'-0"	28'-0"	17'-0"	28'-0"
17'-6"	28'-6"	17'-6"	28'-6"
18'-0"	29'-0"	18'-0"	29'-0"
18'-6"	29'-6"	18'-6"	29'-6"
19'-0"	30'-0"	19'-0"	30'-0"
19'-6"	30'-6"	19'-6"	30'-6"
20'-0"	31'-0"	20'-0"	31'-0"
20'-6"	31'-6"	20'-6"	31'-6"
21'-0"	32'-0"	21'-0"	32'-0"
21'-6"	32'-6"	21'-6"	32'-6"
22'-0"	33'-0"	22'-0"	33'-0"
22'-6"	33'-6"	22'-6"	33'-6"
23'-0"	34'-0"	23'-0"	34'-0"
23'-6"	34'-6"	23'-6"	34'-6"
24'-0"	35'-0"	24'-0"	35'-0"
24'-6"	35'-6"	24'-6"	35'-6"
25'-0"	36'-0"	25'-0"	36'-0"
25'-6"	36'-6"	25'-6"	36'-6"
26'-0"	37'-0"	26'-0"	37'-0"
26'-6"	37'-6"	26'-6"	37'-6"
27'-0"	38'-0"	27'-0"	38'-0"
27'-6"	38'-6"	27'-6"	38'-6"
28'-0"	39'-0"	28'-0"	39'-0"
28'-6"	39'-6"	28'-6"	39'-6"
29'-0"	40'-0"	29'-0"	40'-0"
29'-6"	40'-6"	29'-6"	40'-6"
30'-0"	41'-0"	30'-0"	41'-0"
30'-6"	41'-6"	30'-6"	41'-6"

STATE	PROJECT NO.
MISS.	

REVISION	DATE



ISSUE DATE: MAY 01, 2017

SHEET NUMBER: 6311

MISSISSIPPI DEPARTMENT OF TRANSPORTATION ROADWAY DESIGN DIVISION STANDARD PLAN

BREAKAWAY SIGN SUPPORTS

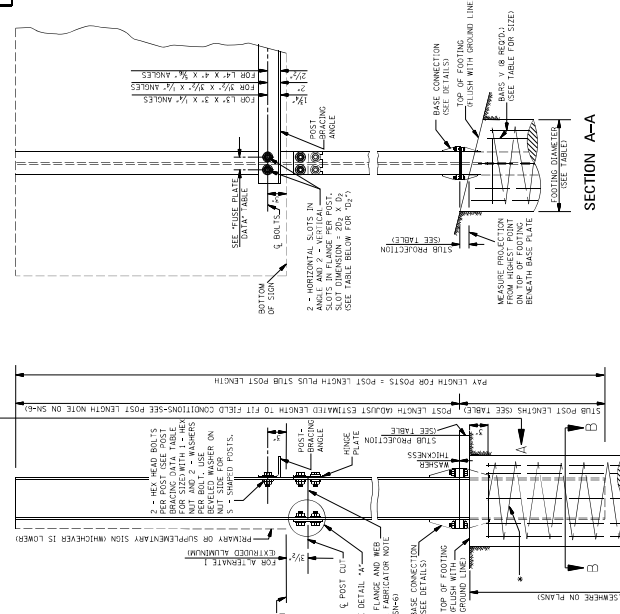

SECTION A-A

GENERAL NOTE:
1. SEE SHAW FOR GENERAL NOTES.

POST BRACING DATA		
POST SIZE	W12 X 26 W10 X 12 W8 X 15 W6 X 12	W6 X 9 W6 X 12 W6 X 15 W6 X 12
DESCRIPTION	3/4" X 2 1/4" 3/4" X 2" 3/4" X 2 1/4" 3/4" X 2"	1/2" X 1 1/2" 1/2" X 1 1/2" 1/2" X 1 1/2" 1/2" X 1 1/2"
ANGLE LENGTH	0'-9"	0'-9"
ANGLE SIZE FOR POST	L4" X 4" X 3/8" L3 1/2" X 3 1/2" X 1/4" L3 1/2" X 3 1/2" X 1/4" L3" X 3" X 1/4"	L4" X 4" X 3/8" L3 1/2" X 3 1/2" X 1/4" L3 1/2" X 3 1/2" X 1/4" L3" X 3" X 1/4"
SPACING OF	11'-0"	14' X 4" X 3/8"

NOTE: Z = DISTANCE BETWEEN 1/3 OF EXTERIOR POSTS.

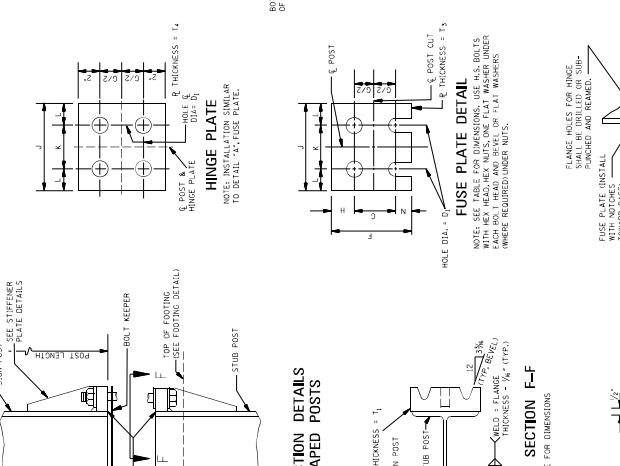

SECTION B-B

GENERAL NOTE:
1. SEE SHAW FOR GENERAL NOTES.

END ELEVATION OF POST AND FOOTING

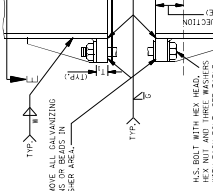

HINGE PLATE

NOTE: INSTALLATION SIMILAR TO DETAIL "A", USE PLATE.

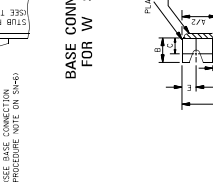

FUSE PLATE DETAIL

NOTE: INSTALLATION SIMILAR TO DETAIL "A", USE PLATE.

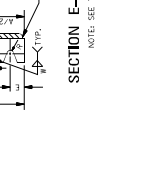

DETAIL "A", FUSE PLATE

NOTE: SEE FABRICATOR NOTE ON SHAW.



BASE CONNECTION DETAILS FOR W SHAPED POSTS

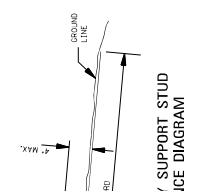

SECTION E-E

NOTE: SEE TABLE FOR DIMENSIONS.



STIFFENER PLATE DETAIL

NOTE: SEE TABLE FOR DIMENSIONS.

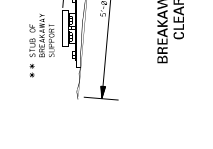



DIAGRAM OF "BOLT KEEPER"

NOTE: FABRICATED FROM Z66 GALVANNEED STEEL. DIMENSIONS AS REQUIRED FOR EACH INSTALLATION.



SHIM DETAIL

NOTE: FABRICATED FROM Z66 GALVANNEED STEEL. DIMENSIONS AS REQUIRED FOR EACH INSTALLATION.



BREAKAWAY SUPPORT STUD CLEARANCE DIAGRAM



BASE CONNECTION DATA		FUSE PLATE DATA													FOOTING DATA												
POST SIZE	BOLT SIZE & TORQUE	A	B	C	D	E	T ₁	T ₂	W	R	F	G	H	J	K	L	N	O ₁	T ₃	MIN. BOLT TENSILE (kips)	MIN. BOLT LENGTH (in)	STUB LENGTH	STUB ** PROJECTION DIAMETER	STUB ** FUSING BARS V SIZE	FOOTING ** DEPTH		
W6 X 9	3/8" x 2 1/2" LONG 300 in-lbs	5"	2"	1/4"	1 1/8"	1 3/8"	1/2"	1/4"	3/8"	1/2"	1/4"	1/2"	1/4"	1/2"	1/4"	1/2"	1/4"	1/2"	1/4"	12,050	12,050	1/4"	2'-0"	3"	2'-0"	4#	SEE NOTE BELOW
W6 X 15	3/8" x 2 1/2" LONG 300 in-lbs	5"	2"	1/4"	1 1/8"	1 3/8"	1/2"	1/4"	3/8"	1/2"	1/4"	1/2"	1/4"	1/2"	1/4"	1/2"	1/4"	1/2"	1/4"	15,200	15,200	1/4"	2'-0"	3"	2'-0"	4#	SEE NOTE BELOW
W8 X 21	3/8" x 3 1/2" LONG 500 in-lbs	6"	2 1/4"	1 1/8"	1 1/4"	1 1/4"	1/2"	1/4"	3/8"	1/2"	1/4"	1/2"	1/4"	1/2"	1/4"	1/2"	1/4"	1/2"	1/4"	28,400	28,400	1/4"	2'-0"	3"	2'-0"	4#	SEE NOTE BELOW
W10 X 22	3/8" x 3 1/2" LONG 500 in-lbs	6"	2 1/4"	1 1/8"	1 1/4"	1 1/4"	1/2"	1/4"	3/8"	1/2"	1/4"	1/2"	1/4"	1/2"	1/4"	1/2"	1/4"	1/2"	1/4"	28,400	28,400	1/4"	2'-0"	3"	2'-0"	4#	SEE NOTE BELOW
W12 X 26	3/8" x 3 1/2" LONG 500 in-lbs	6"	2 1/4"	1 1/8"	1 1/4"	1 1/4"	1/2"	1/4"	3/8"	1/2"	1/4"	1/2"	1/4"	1/2"	1/4"	1/2"	1/4"	1/2"	1/4"	28,400	28,400	1/4"	2'-0"	3"	2'-0"	4#	SEE NOTE BELOW

*** NOTE: STUB PROJECTION OVERLAP REQUIRED OVER A 30-DEGREE ROADWAY SIGN, LAMPARMS AND TRAFFIC SIGNALS, LATEST EDITION. HIGHWAY SIGN, LAMPARMS AND TRAFFIC SIGNALS, LATEST EDITION. *** NOTE: FOOTING DEPTH TO BE SHOWN ELSEWHERE IN THE PLANS.

STATE PROJECT NO.
MISS.

BOLT KEEPER PLATE DETAIL

NOTE: TO BE FABRICATED FROM 28 GAGE TYPE 430 STAINLESS STEEL. CAPS TO BE INSTALLED AS SHOWN IN DETAIL AT UPPER LEFT.

GENERAL NOTES: (SEE MK. NO. SN-6 FOR ADDITIONAL GENERAL NOTES)

- THE TOP PLATE OF THE TRIANGULAR SLIP BASE SHALL HAVE THE SAME EXTERIOR DIMENSIONS AS THE BOTTOM PLATE. THE LIFTING CONE SHALL BE WELDED TO THE BOTTOM PLATE ONLY. A HOLE EQUAL TO THE INSIDE DIAMETER OF THE SIGN POST SHALL BE LOCATED AT THE CENTER OF THE TOP PLATE WITH THE HOLE EDGE BEVELLED AS DETAILED. TOP & BOTTOM PLATES SHALL BE SYMMETRICAL FOR THE PURPOSE OF ASSEMBLY IN ANY POSITION.
- BASE CONNECTION ASSEMBLY AS FOLLOWS:
 - ASSEMBLE POST TO STUB WITH 3 BOLTS AND WITH 3 FLAT WASHERS PER BOLT.
 - SHIM AS REQUIRED TO PLUMB POST TO BE ASSEMBLED WITH A 1/2" TO 3/8" GROUND ANGLE PER BOLT TO BE ASSEMBLED WITH 157° TO CLEAN THREADS.
 - LOOSEN EACH BOLT IN TURN & RETIGHTEN IN A SYSTEMATIC MANNER TO PRESCRIBED TORQUE. SEE BASE CONNECTION DATA TABLE.
 - BURR THREADS AT JUNCTION WITH NUT WITH A CENTER PUNCH TO PREVENT NIT FROM LOOSENING.
- FRICTION CAPS TO BE MANUFACTURED FROM HOT ROLLED OR COLD ROLLED STEEL SHEETS. FOR ALL PIPE SIZES, MINIMUM THICKNESS SHALL BE 20 GAGE SHEET METAL. RIM EDGES SHALL BE REASONABLY STRAIGHT AND SMOOTH. CAPS SHALL BE MANUFACTURED WITH A MINIMUM OF 1/4" TO 3/8" RADIUS AT A DRIVE-IN FRICTION FIT AND HAVE NO TENDENCY TO ROCK WHEN SEATED ON PIPE. THE DEPTH SHALL BE SUFFICIENT TO GIVE POSITIVE PROTECTION AGAINST ENTRANCE OF RAINWATER. CAPS SHALL BE MANUFACTURED WITH A 30° BEVEL AT THE TOP AND SHOW NO SIGNS OF METAL FRACTURE. ALL CAPS TO BE SAME IN SHAPE AND GENERAL APPEARANCE AS APPROVED BY THE ENGINEER.
- STUB PROTECTION SHOULD BE MEASURED OVER A 5"-8" CHORD AS PER ASHPO LIPED SPECIFICATIONS FOR STRUCTURAL SUPPORTS FOR TRUCK SIGNAGE. SEE MK. NO. SN-6A FOR DIAGRAM. LATEST EDITION. SEE MK. NO. SN-6A FOR DIAGRAM.

MISSISSIPPI DEPARTMENT OF TRANSPORTATION
ROADWAY DESIGN DIVISION
STANDARD PLAN

**BREAKAWAY
SIGN SUPPORTS**

DATE: _____
ISSUE DATE: MAY 01, 2017

SHEET NUMBER
SH-05
6312

FRICTION CAP DETAIL

NOTE: SEE NOTE 3

POST ELEVATION

PAY LENGTH FOR POST = POST LENGTH + STUB LENGTH

SEE DETAILS ELSEWHERE ON PLANS

SEE DETAILS ELSEWHERE ON PLANS

SEE DETAILS ELSEWHERE ON PLANS

SPACE BETWEEN PLATES DUE TO WASHERS & BOLT KEEPER

SHIM DETAIL

NOTE: FINISH 200/30/24. TILES AND 200/30/24. TILES PER FOOT SHIMS SHALL BE FABRICATED FROM BRASS SHIM STOCK OR STRIP CONFORMING TO ASTM B 36.

MULTI-DIRECTIONAL SIGN POST & STUB POST

U.S. HEX. BOLT PER TABLE FOR SIZE. 3 WASHERS ALSO REQUIRED PER BOLT.

SECTION A-A

NOTE: SEE DATA TABLE FOR DIMENSIONS

PROVIDE 1/2" DIA. MAX. HOLE IN THE INSIDE RADIUS OF THE STUB POST FOR GALVANIZE DRAINAGE.

PRIMARY FLOW OF TRAFFIC

BASE CONNECTION DATA TABLE

DIMENSIONS	BOLT	WASHER	T	W	C	D	E	F	G	H	J	K	L	M	N	P	S	U	V	R
PIPE SIZES	SIZE	SIZE	SIZE	SIZE	SIZE	SIZE	SIZE	SIZE	SIZE	SIZE	SIZE	SIZE	SIZE	SIZE	SIZE	SIZE	SIZE	SIZE	SIZE	SIZE
3"	3/8"	3/8"	3/8"	3/8"	1"	108"	2 3/8"	1/2"	3/8"	1/2"	1 3/4"	3/2"	1 3/4"	1 1/4"	7/8"	6"	9"	2"	4 1/4"	7/8"
3 1/2"	3/8"	3/8"	3/8"	3/8"	1 1/4"	133"	2 3/8"	1/2"	3/8"	1/2"	2 1/2"	4 1/2"	2 1/4"	1 1/4"	7/8"	7 1/2"	11 1/4"	2 1/2"	5 1/4"	9/8"
5"	3/8"	3/8"	3/8"	3/8"	1 3/4"	157"	2 3/8"	1/2"	3/8"	1/2"	3 1/4"	5 1/2"	2 3/4"	1 1/2"	7/8"	9"	12 1/4"	2 1/2"	5 3/4"	9/8"

* NOTE: APPROXIMATE DIMENSIONS

FRICION CAP DETAIL (SEE DETAIL)

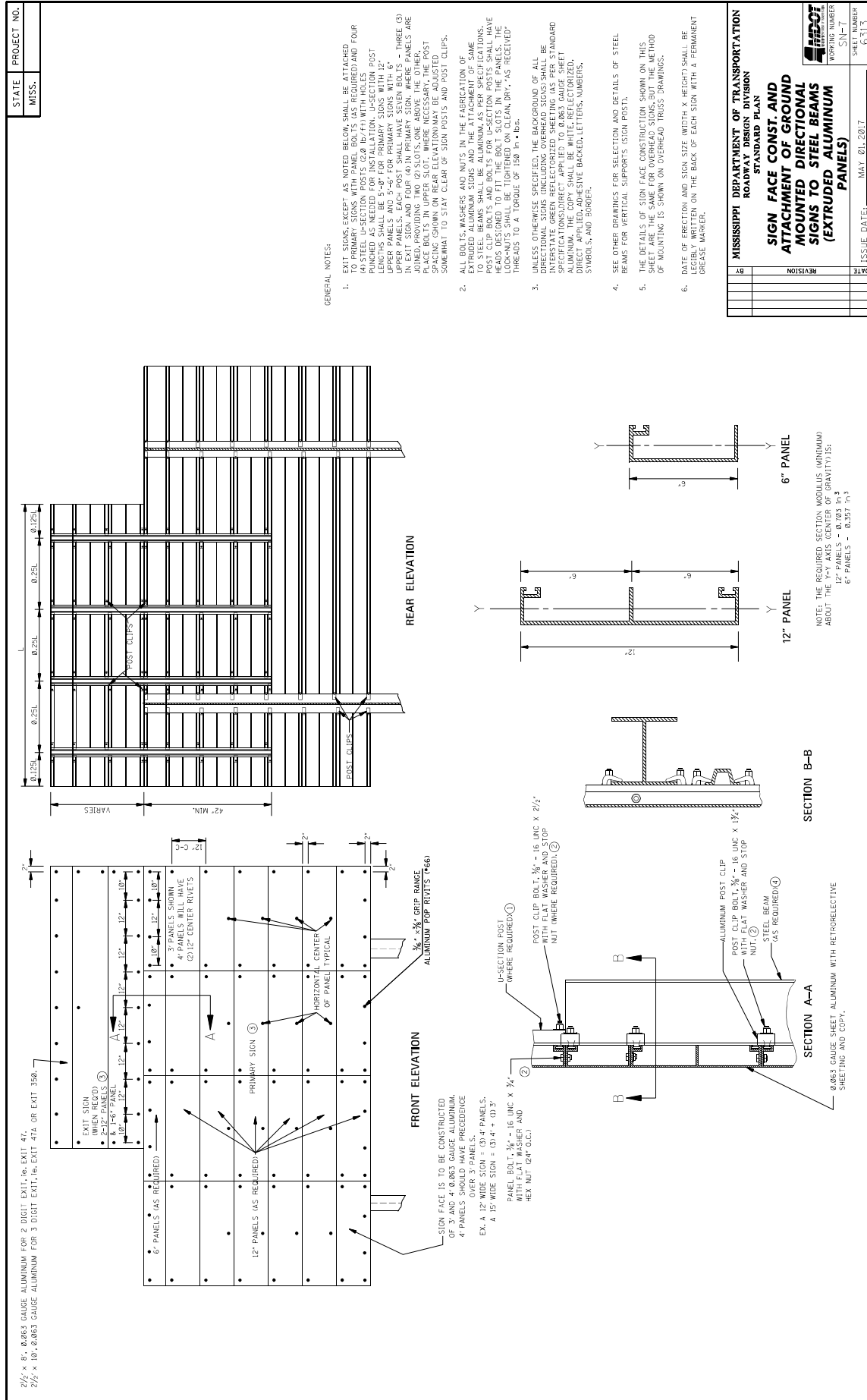

STATE MISS.	PROJECT NO.	
----------------	-------------	--

DISTANCE REFERENCE SIGN-MOUNTING ON OUTSIDE SHOULDER ALONG MAIN FACILITY

NOTE: SIGN MOUNTING ON LEFT LANE SHOULDER SHALL BE 90° OPPOSITE THE RIGHT LANE STATION. SIGN MOUNTING ON RIGHT LANE SHOULDER SHALL BE LOCATED WITHIN 500 FEET OF ITS TRUE LOCATION. IT SHALL BE OMITTED ENTIRELY.

DELINATOR MOUNTING ON OUTSIDE SHOULDER ALONG MAIN FACILITY OR RAMP

DELINATOR MOUNTING ON OUTSIDE SHOULDER WITH MOUNTABLE CURB ALONG MAIN FACILITY OR RAMP

DELINATOR MOUNTING ON INTERCHANGE LOOPS WITH UNMOUNTABLE CURB ON INSIDE

DETAIL OF SINGLE WHITE OR SINGLE YELLOW DELINEATOR

DETAIL OF DOUBLE WHITE OR DOUBLE YELLOW DELINEATOR

REAR VIEW OF DELINEATOR ASSEMBLY

NOTE: DELINEATORS ARE TO BE FASTENED TO U-SECTION POSTS WITH 1/4\"/>

MOUNTING DETAIL

NOTE: DELINEATORS ARE TO BE FASTENED TO U-SECTION POSTS WITH 1/4\"/>

DETAIL OF TYPE 3 OBJECT MARKER INSTALLATION

NOTE: TYPE 3 OBJECT MARKER AND DISTANCE REFERENCE SIGNS ARE TO BE FASTENED TO U-SECTION POSTS WITH 3/8\"/>

REAR VIEW OF TYPE 3 OBJECT MARKER OR DISTANCE REFERENCE SIGN ASSEMBLY

NOTE: DELINEATORS AND TYPE 3 OBJECT MARKER SHALL BE REFLECTIVE SHEETING ON 8.000\"/>

GENERAL NOTES:

1. DELINEATORS AND TYPE 3 OBJECT MARKER SHALL BE REFLECTIVE SHEETING ON 8.000\"/>
2. DELINEATOR, TYPE 3 OBJECT MARKER AND DISTANCE REFERENCE SIGN POSTS SHALL BE GALVANIZED STEEL. THE POSTS ARE TO BE FABRICATED BEFORE THE METAL IS GALVANIZED.
3. WEIGHT WITHOUT GROUND PLATES:
 - A. DELINEATOR POST 7'-0\"/>
 - B. TYPE 3 OBJECT MARKER POSTS 3'-0\"/>
 - C. DISTANCE REFERENCE SIGNS 12'-0\"/>
4. UNIT PRICES OF DELINEATORS AND TYPE 3 OBJECT MARKERS SHALL INCLUDE COST OF POST, DISTANCE REFERENCE SIGN POST WILL BE PAID FOR PER FOOT, ROLLED SECTION.
5. RADIUS IN BENDS OF POST CROSS SECTION NOT TO EXCEED 9/16\"/>
6. GROUND PLATE NOT REQUIRED ON U-SECTION POST.

DELINATOR, TYPE 3 OBJECT MARKER AND TYPE 4 OBJECT MARKERS SHALL INCLUDE COST OF POST, DISTANCE REFERENCE SIGN POST WILL BE PAID FOR PER FOOT, ROLLED SECTION.

MISSISSIPPI DEPARTMENT OF TRANSPORTATION
ROADWAY DESIGN DIVISION
STANDARD PLAN

TYPICAL INSTALLATION AND DETAILS OF DELINEATORS AND DISTANCE REFERENCE SIGNS

DRAWING NUMBER: SN-5
SHEET NUMBER: 8214
ISSUE DATE: MAY 01, 2017

DATE	REVISION

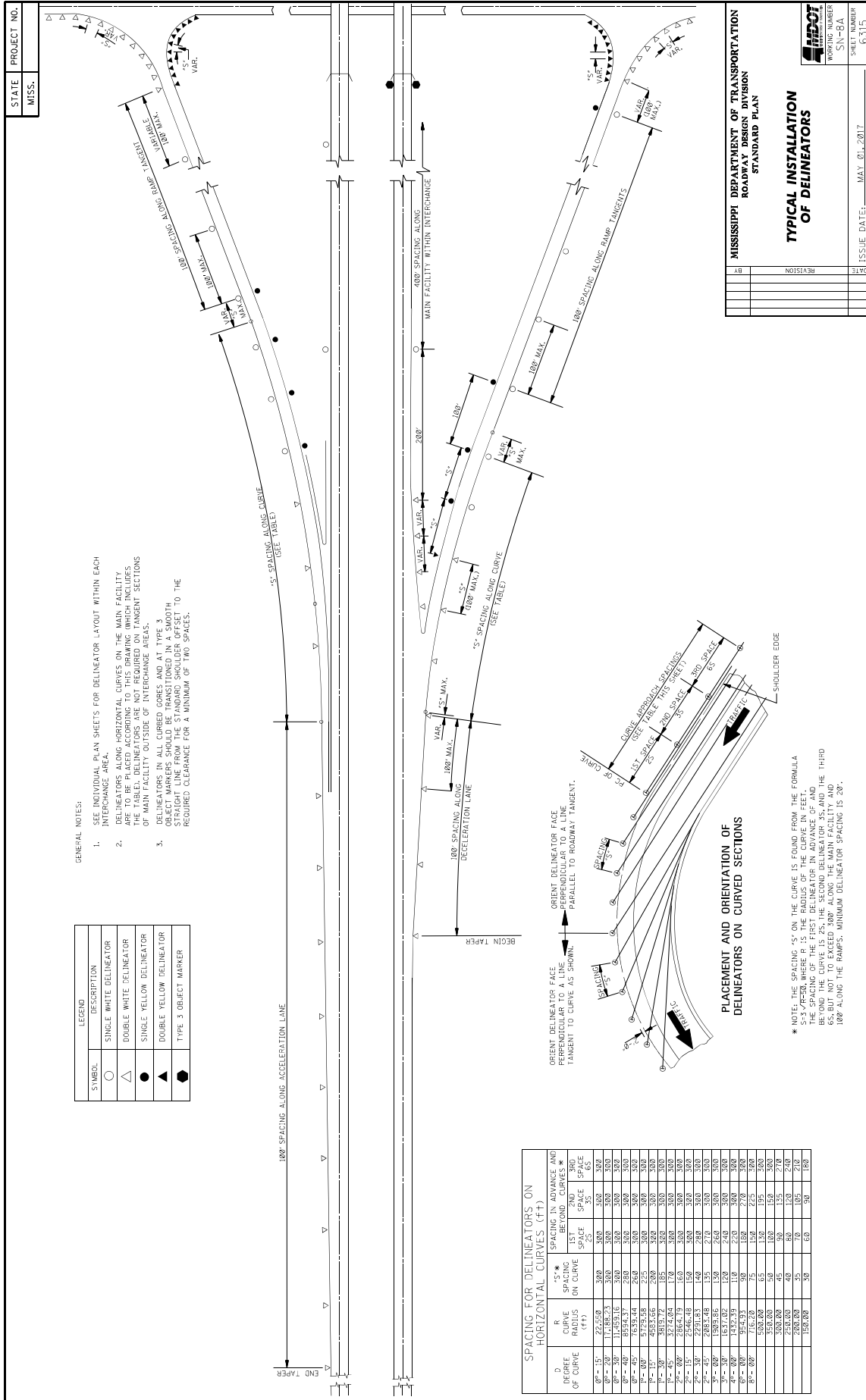

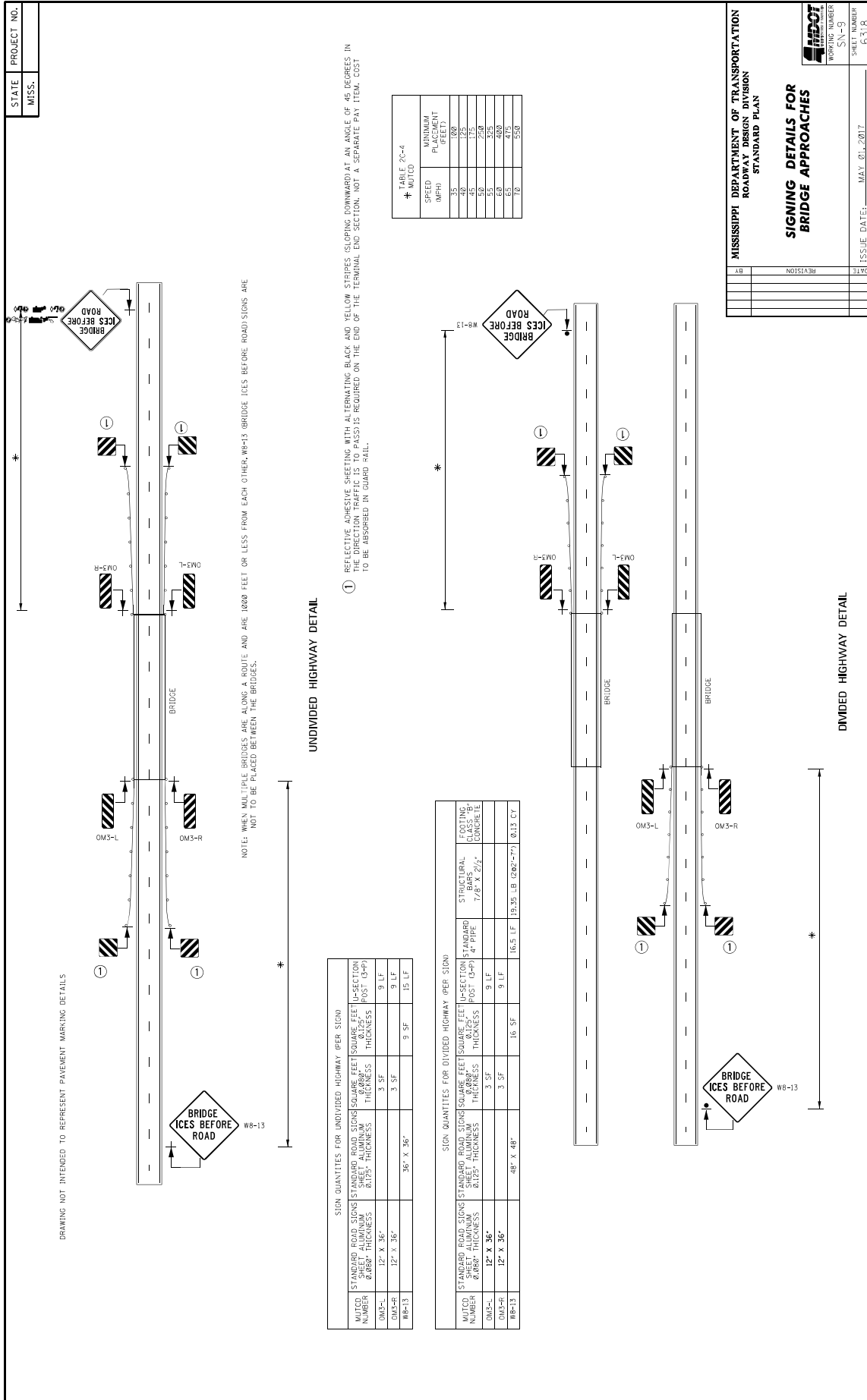

MISSISSIPPI DEPARTMENT OF TRANSPORTATION

SECTION 904 – NOTICE TO BIDDERS NO. 3599

CODE: (SP)

DATE: 08/11/2021

SUBJECT: Standard Drawings

Standard Drawings attached hereto shall govern appropriate items of required work.

Larger copies of Standard Drawings may be purchased from:

MDOT Plans Print Shop
MDOT Shop Complex, Building C, Room 114
2567 North West Street
P.O. Box 1850
Jackson, MS 39215-1850
Telephone: (601) 359-7460
or FAX: (601) 359-7461
or e-mail: plans@mdot.state.ms.us

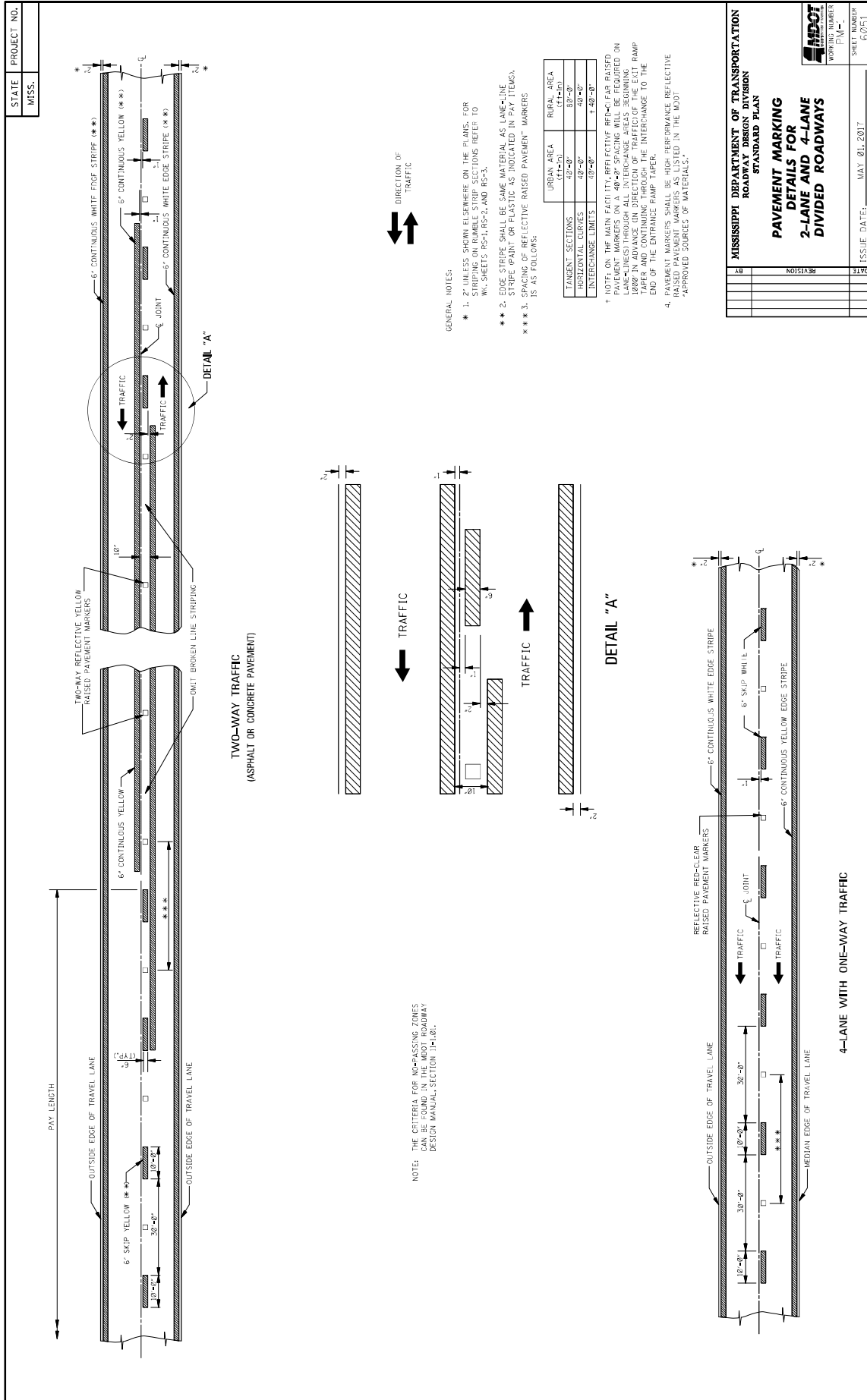

MISSISSIPPI DEPARTMENT OF TRANSPORTATION	
ROADWAY DESIGN DIVISION	
STANDARD PLAN	
PAVEMENT MARKING	
2-LANE AND 4-LANE	
DIVIDED ROADWAYS	
DATE	ISSUE DATE: MAY 01, 2017
BY	SHEET NUMBER 6001
REVISION	WORKING NUMBER P.M.-

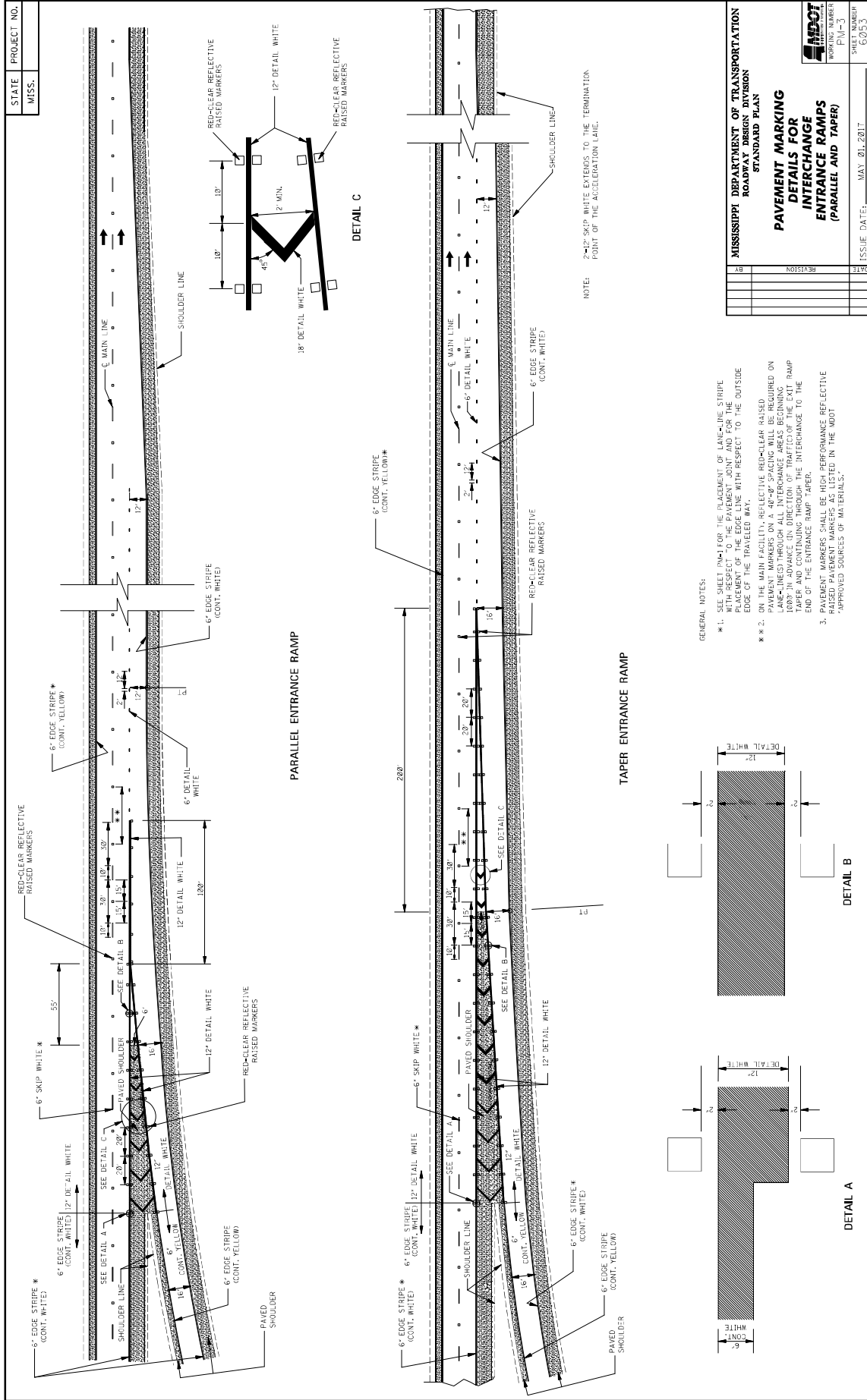

MISSISSIPPI DEPARTMENT OF TRANSPORTATION ROADWAY DESIGN DIVISION	
BY	REVISION
DATE	
SHEET NUMBER	PLN-3
SHEET TOTAL	60/53
ISSUE DATE:	MAY 20, 2017

**PAVEMENT MARKING
DETAILS FOR
INTERCHANGE RAMP
(PARALLEL AND TAPER)**

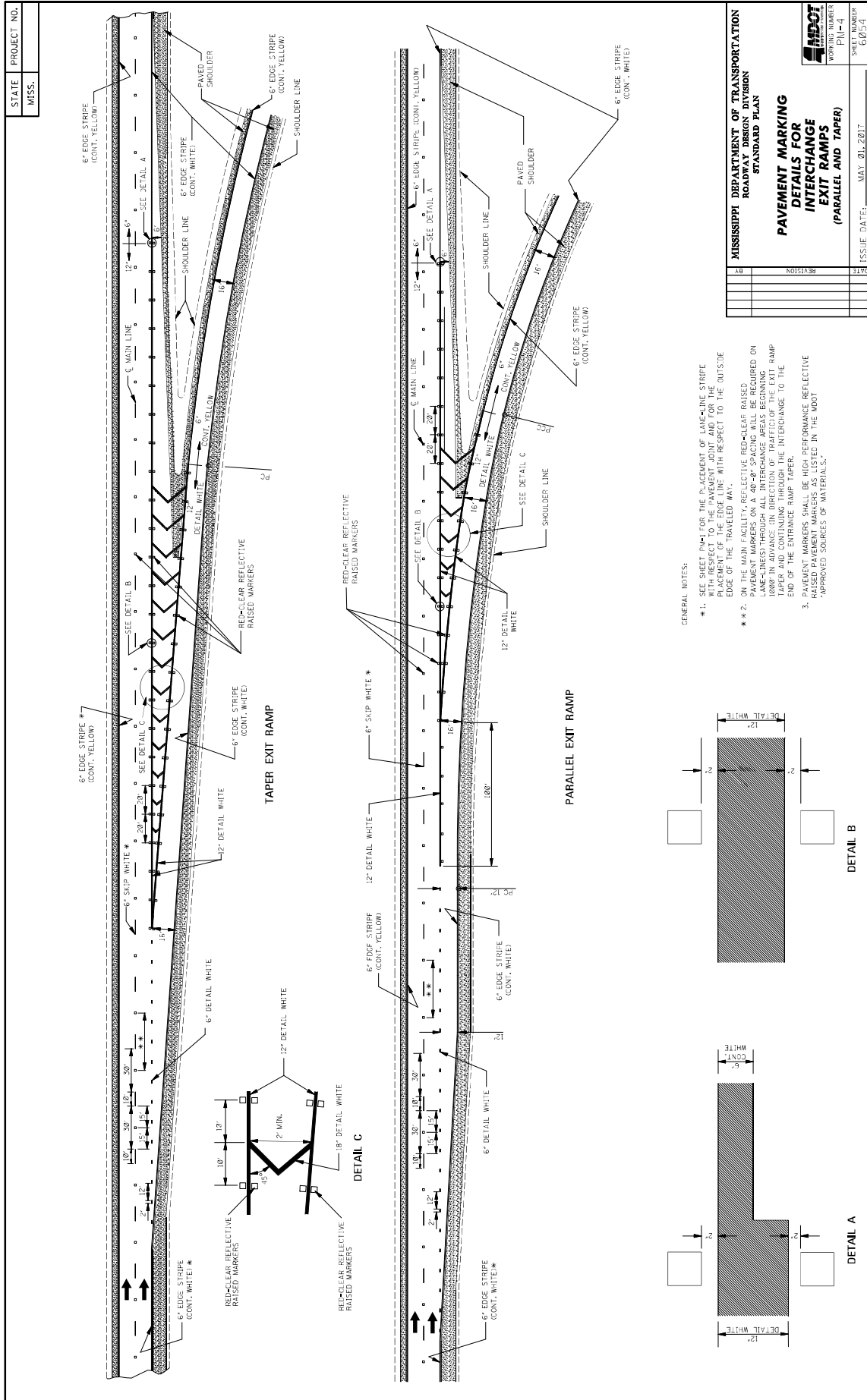

MISSISSIPPI DEPARTMENT OF TRANSPORTATION	
ROADWAY DESIGN DIVISION	
STANDARD PLAN	
PAVEMENT MARKING	
INTERCHANGE	
EXIT RAMP	
(PARALLEL AND TAPER)	
SHEET NUMBER	PL-4
WORKING NUMBER	62/241
ISSUE DATE:	MAY 01, 2017
DATE	REVISION

STATE MISS.	PROJECT NO.										
----------------	-------------	--	--	--	--	--	--	--	--	--	--

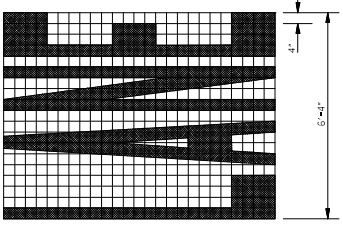

6'-4"

8'-4"

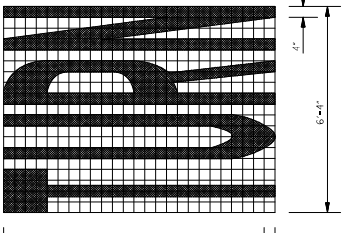

6'-4"

8'-4"

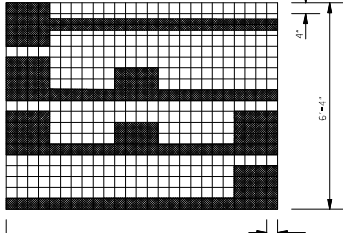

6'-4"

8'-4"

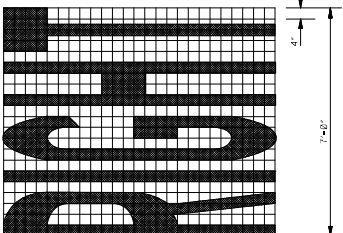

7'-0"

8'-4"

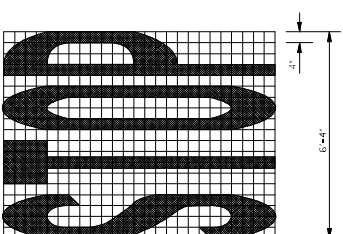

6'-4"

8'-4"

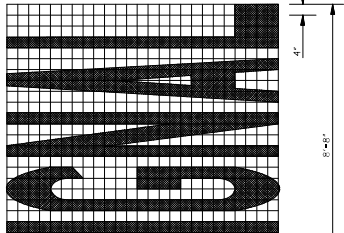

6'-4"

8'-4"

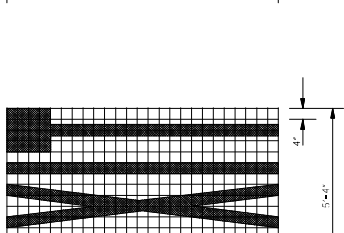

5'-4"

8'-4"

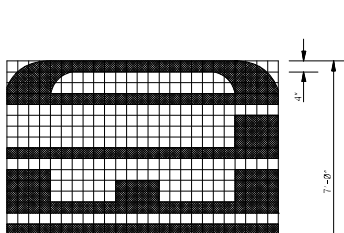

7'-0"

8'-4"

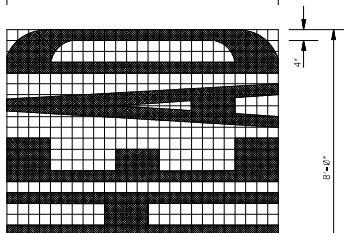

8'-0"

8'-4"

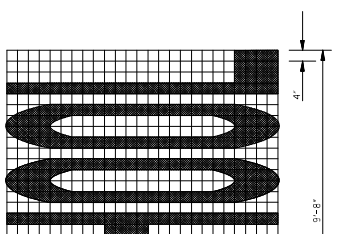

9'-8"

8'-4"

GENERAL NOTES:

- TWO HORIZONTAL GAPS (USED BY TEMPLATE CONNECTIONS) OF 1/4" SHALL BE EXTENDED THROUGH ALL WIDTHS OF LETTERS.
- FOR OTHER DETAILS, SEE THE MANUAL ON UNIFORM TRAFFIC CONTROL DEVICES.
- PAY QUANTITIES FOR PAVEMENT MARKING LEGENDS ARE AS FOLLOWS:

LEGEND	AREA (ft ²)
STOP	24.6
RIGHT	28.6
LEFT	19.5
YIELD	22.2
AHEAD	32.4
YIELD	26.8
EXIT	18.5
SIGNAL	32.5
SCHOOL	35.2

MISSISSIPPI DEPARTMENT OF TRANSPORTATION
ROADWAY DESIGN DIVISION
STANDARD PLAN

**PAVEMENT MARKING
LEGEND DETAILS**

DATE	ISSUE DATE: MAY 01, 2017
BY	
REVISION	

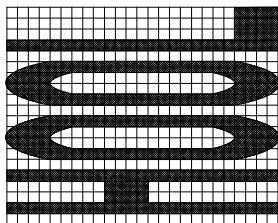

WORKING NUMBER
PM-5

SHEET NUMBER
6055

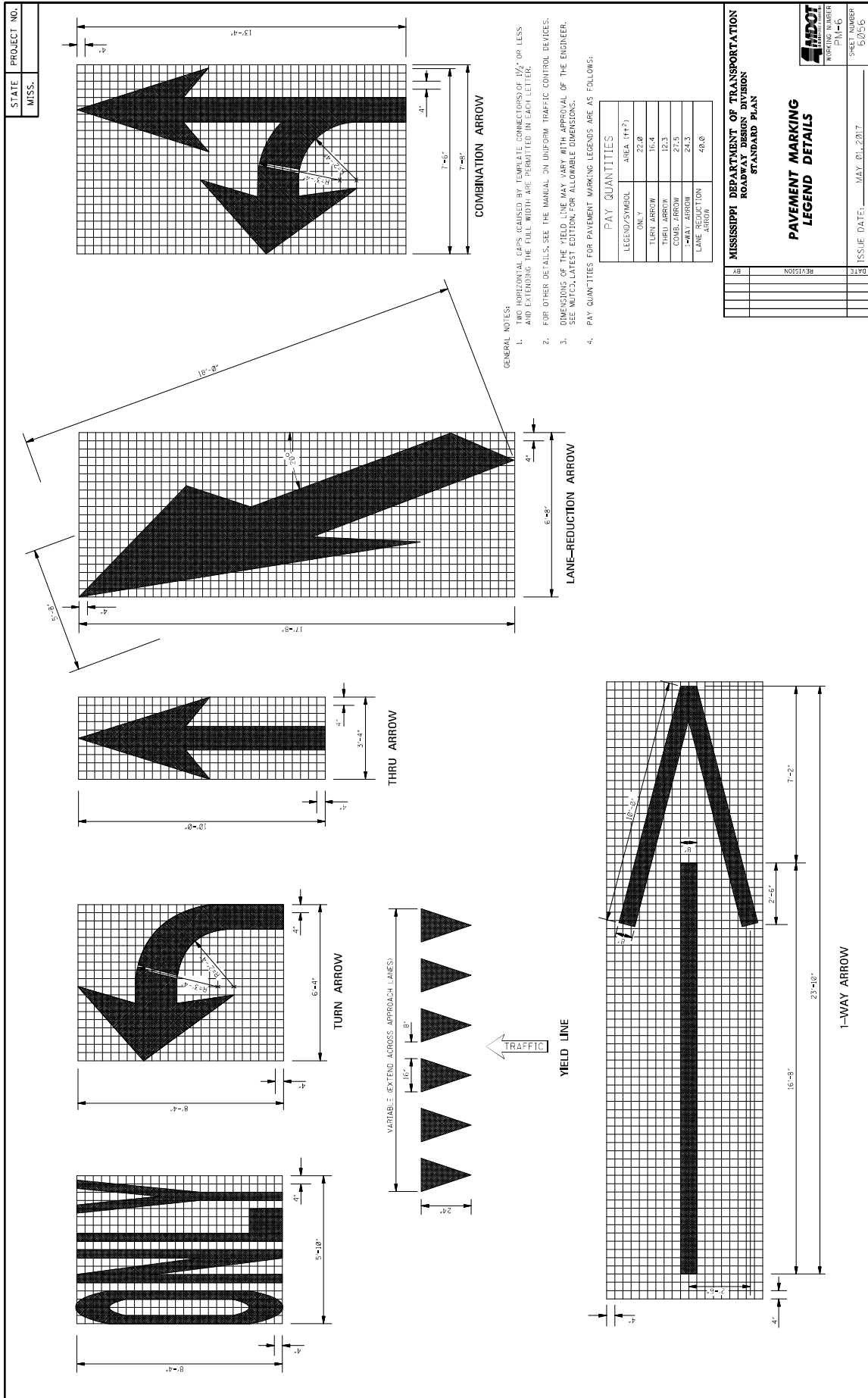

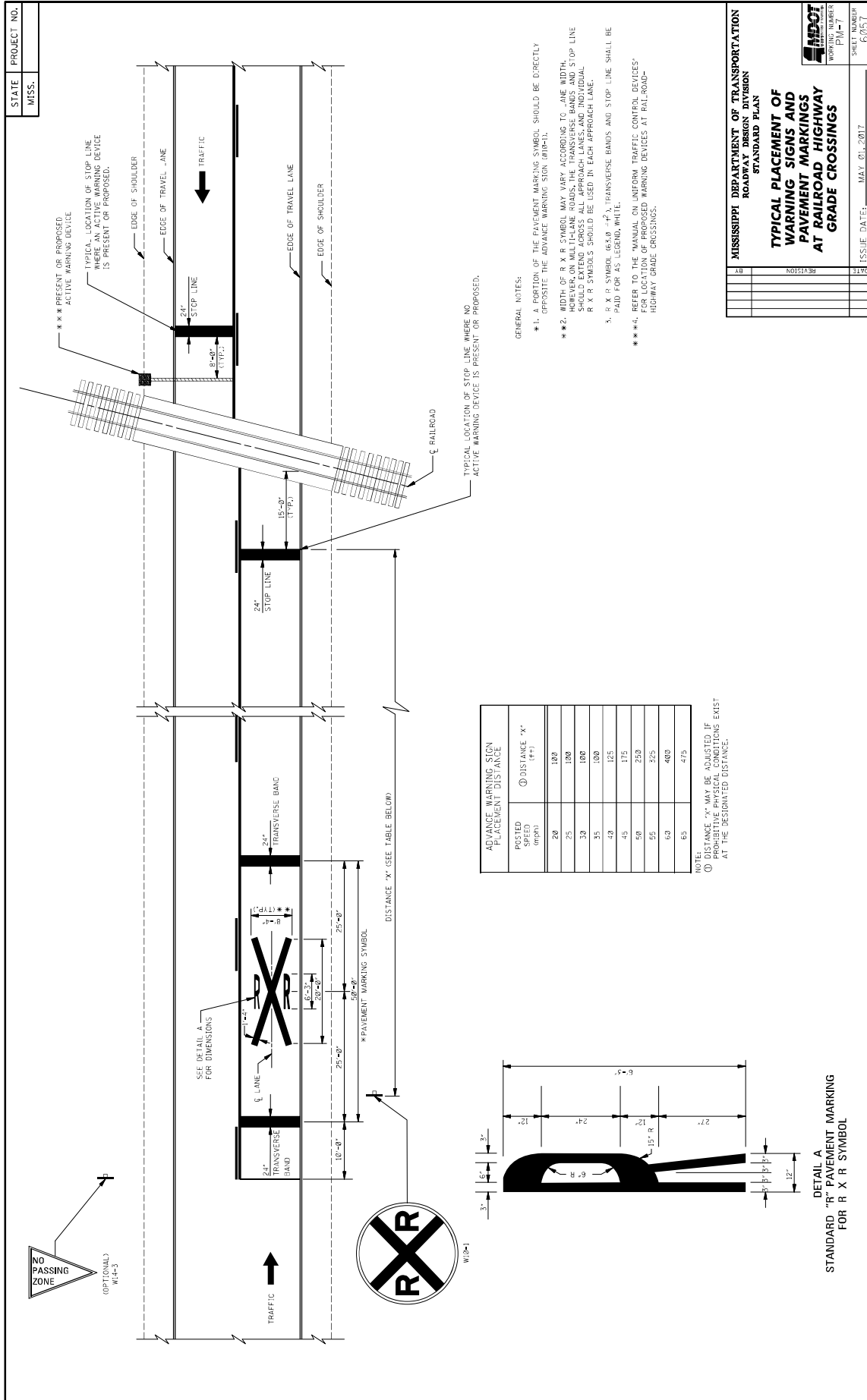

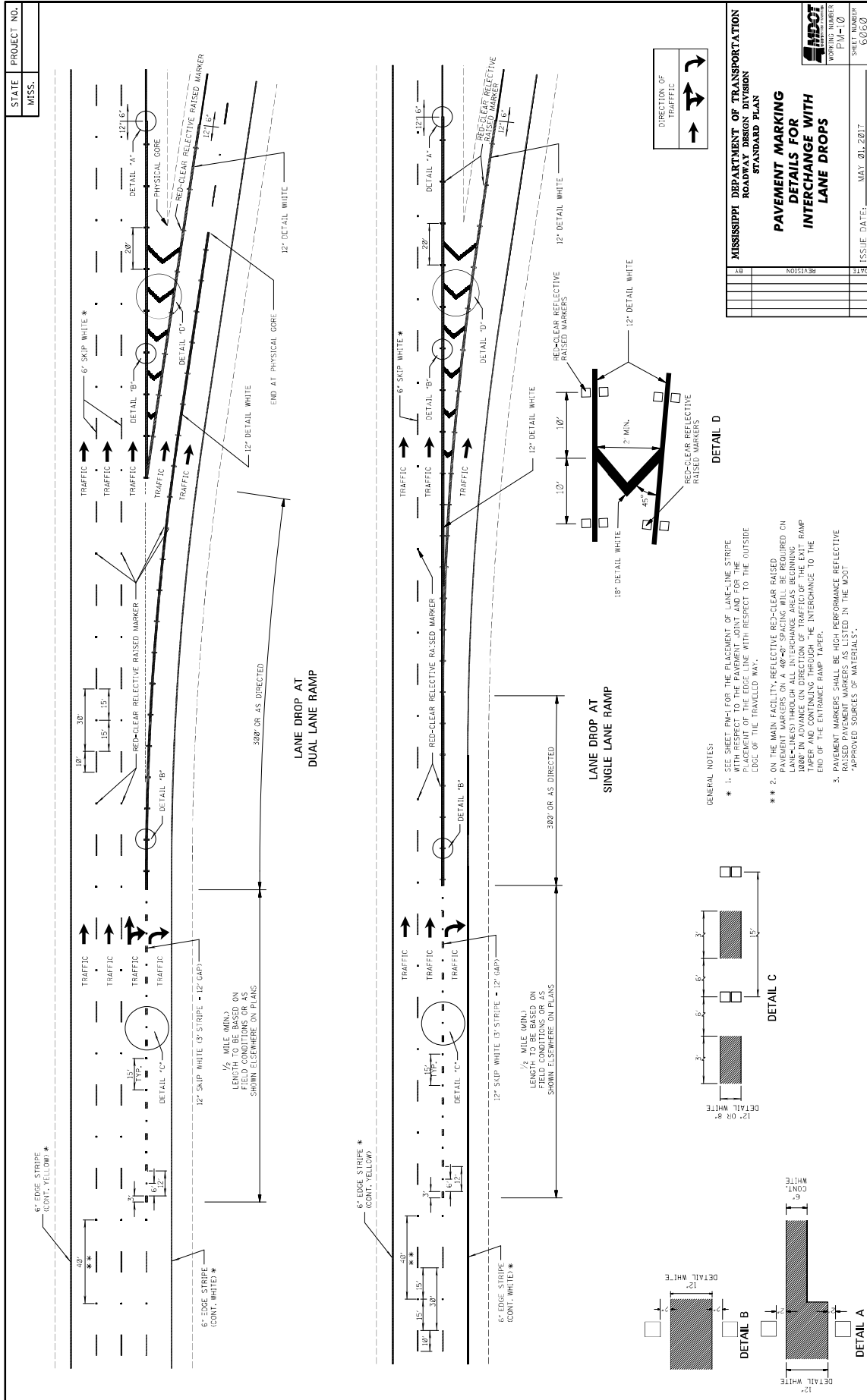

MISSISSIPPI DEPARTMENT OF TRANSPORTATION ROADWAY DESIGN DIVISION STANDARD PLAN	
PAVEMENT MARKING DETAILS FOR INTERCHANGE WITH LANE DROPS	
WORKING NUMBER P.M-10	SHEET NUMBER 000500
DATE	ISSUE DATE: MAY 01, 2017

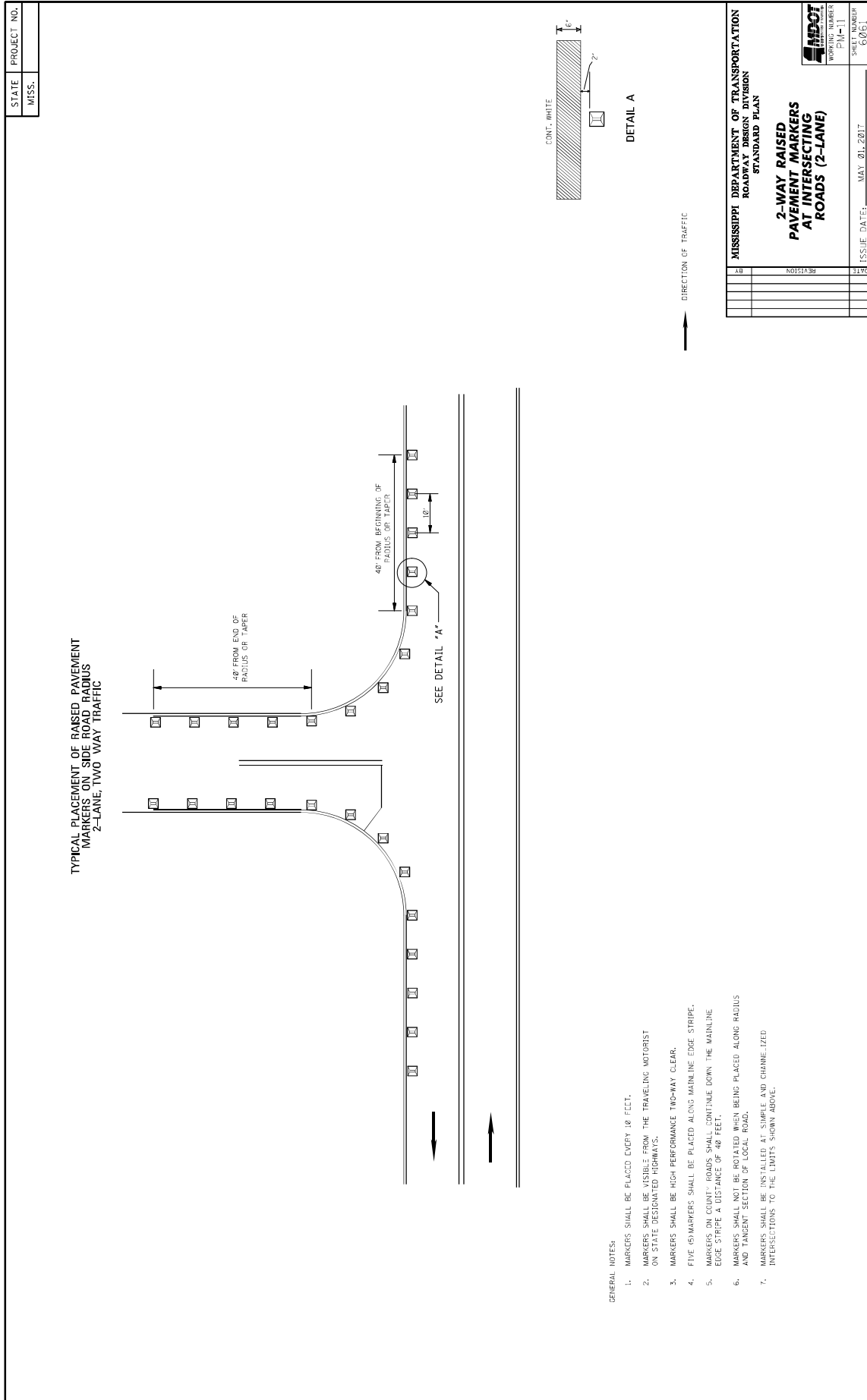

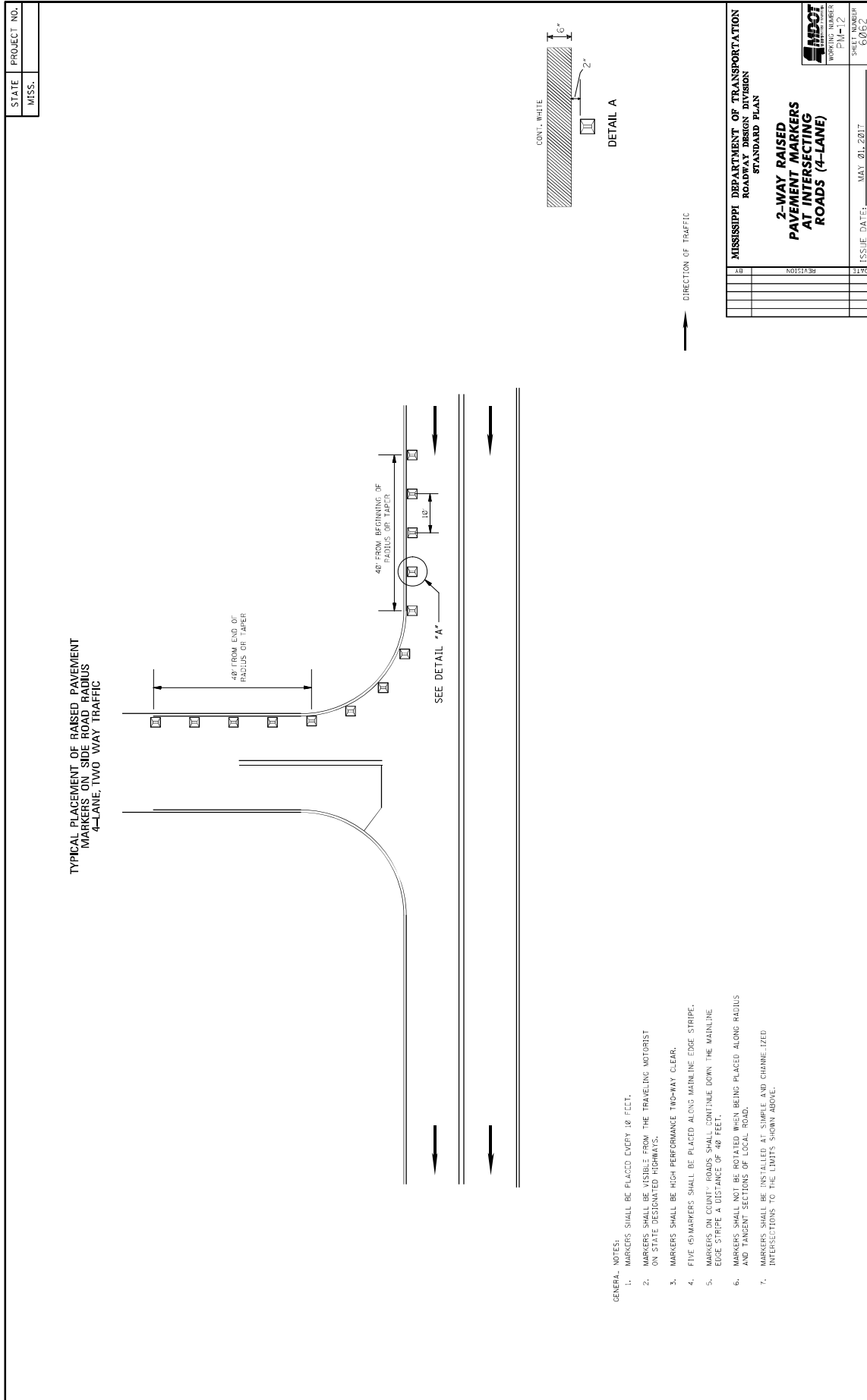

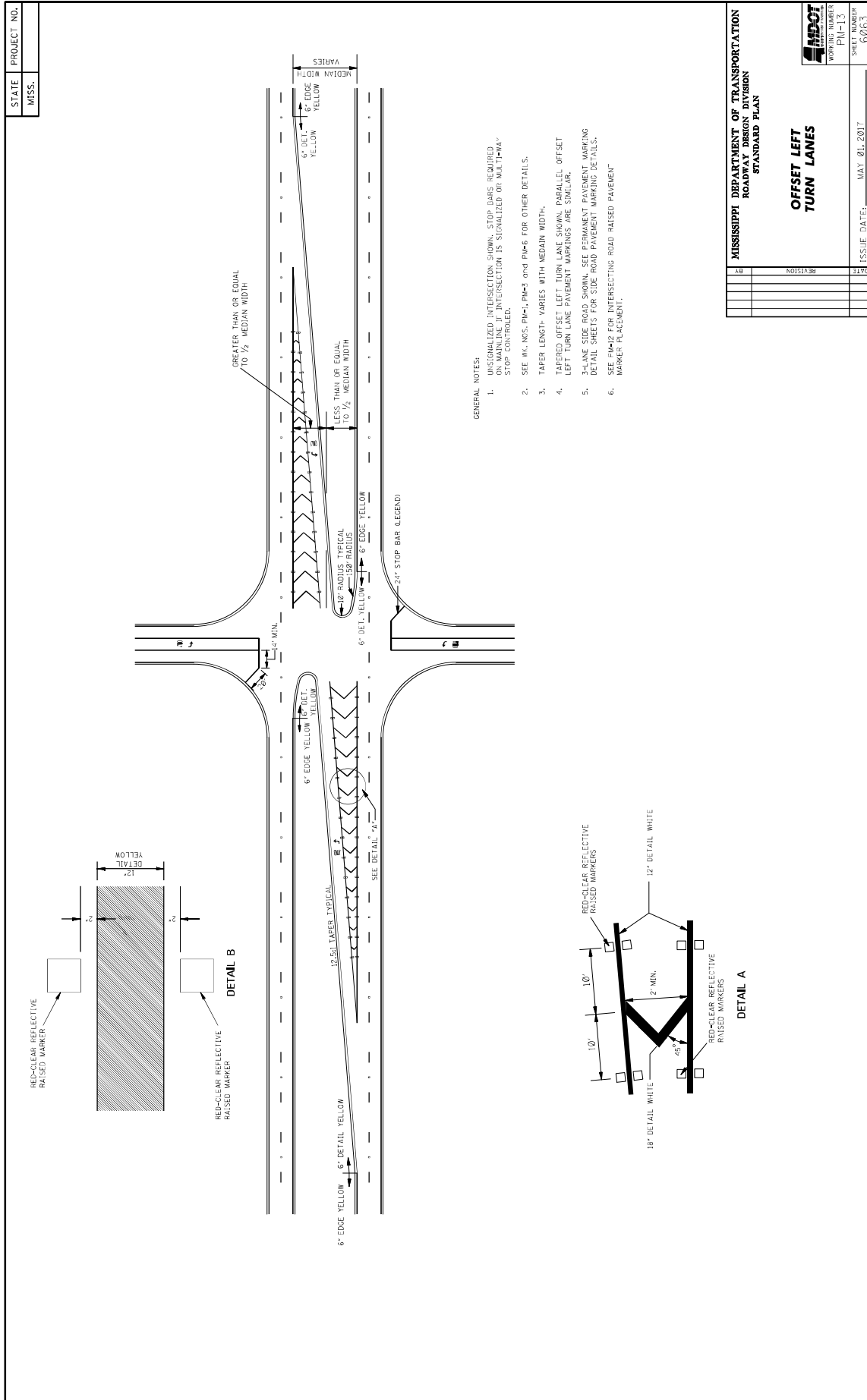

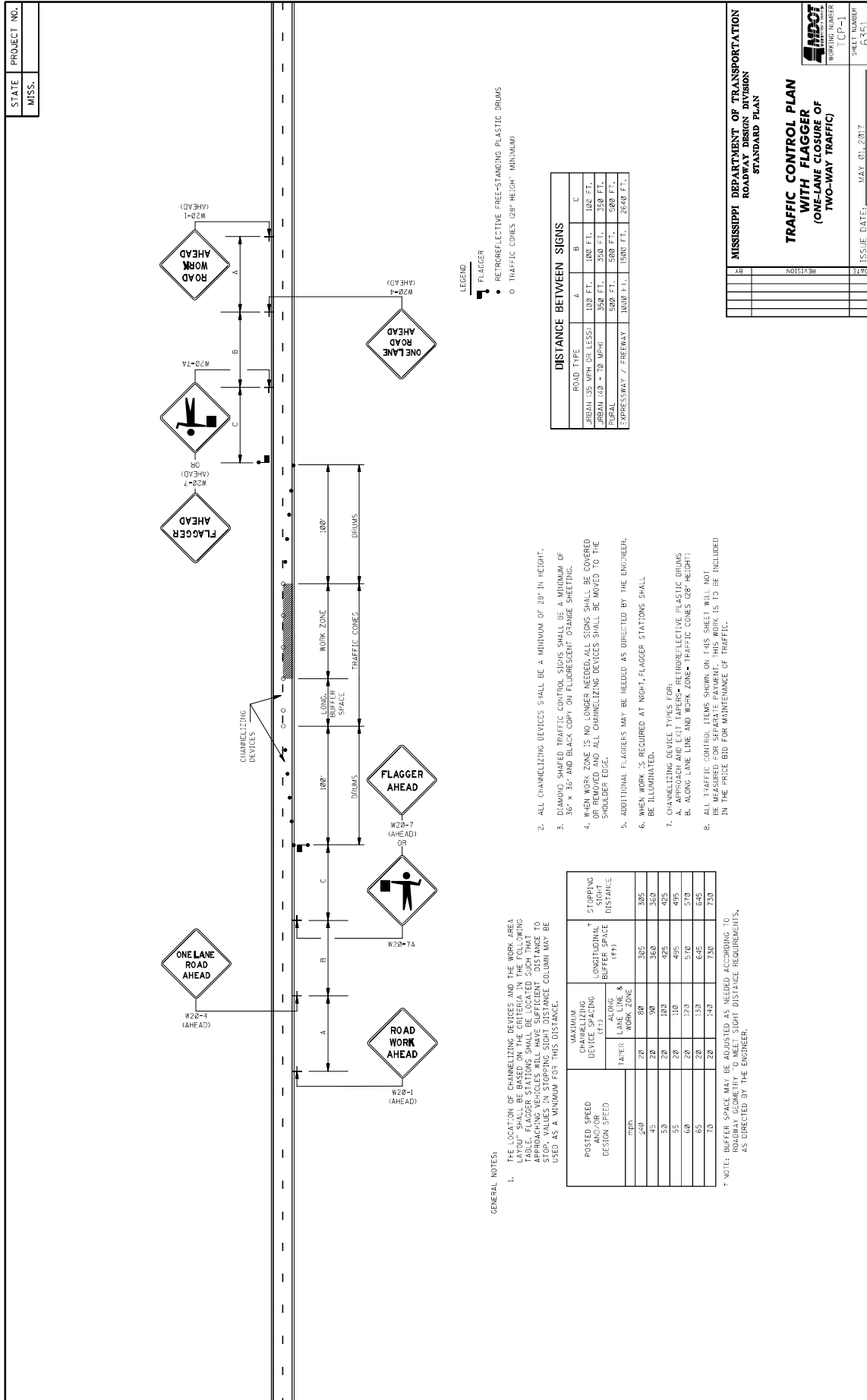

MISSISSIPPI DEPARTMENT OF TRANSPORTATION
ROADWAY DESIGN DIVISION
STANDARD PLAN

TRAFFIC CONTROL PLAN
WITH FLAGGER
(ONE-LANE CLOSURE OF TWO-WAY TRAFFIC)

ISSUE DATE: MAY 01, 2017

WORKING NUMBER: [CP-1]
SHEET NUMBER: 6351

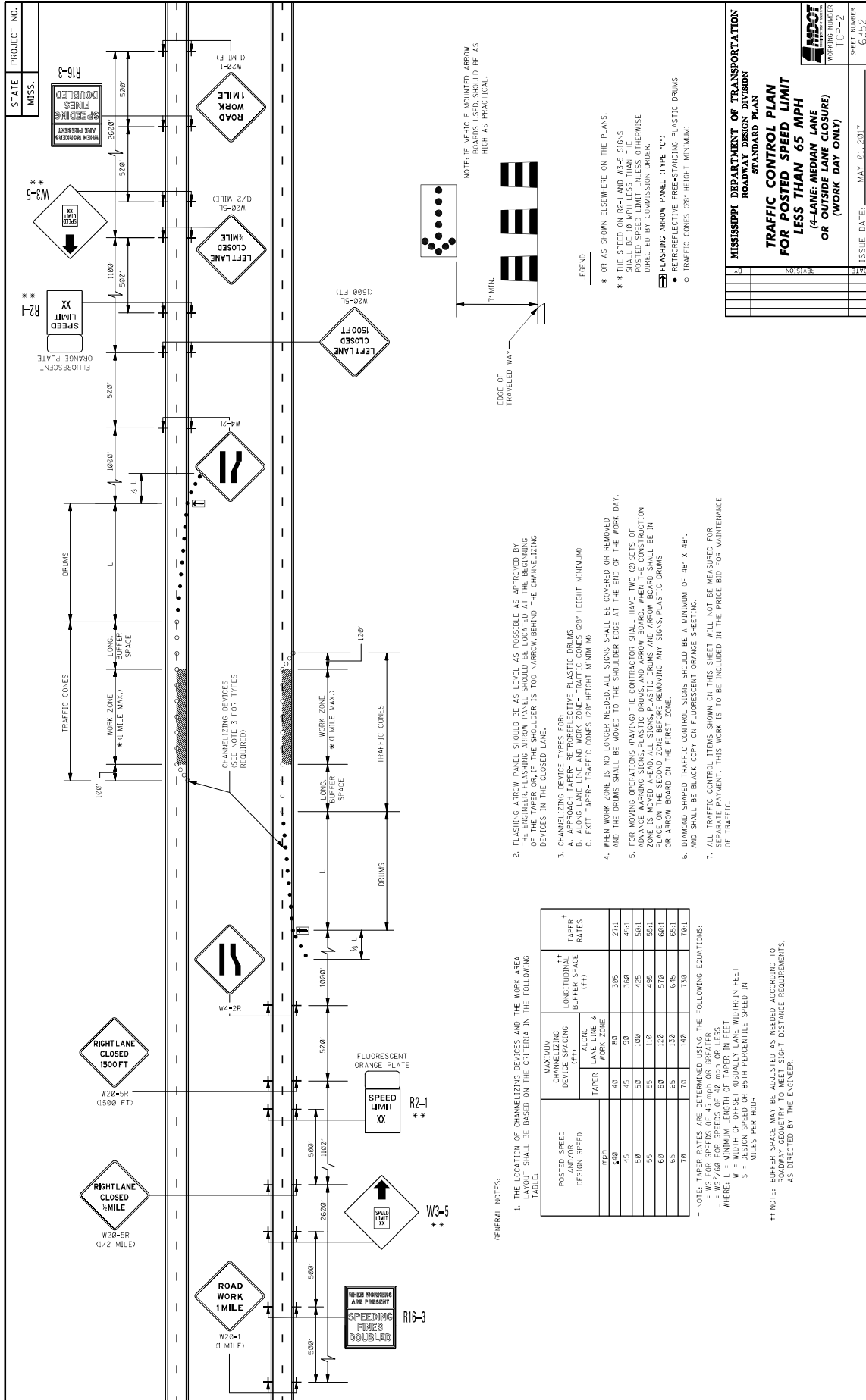

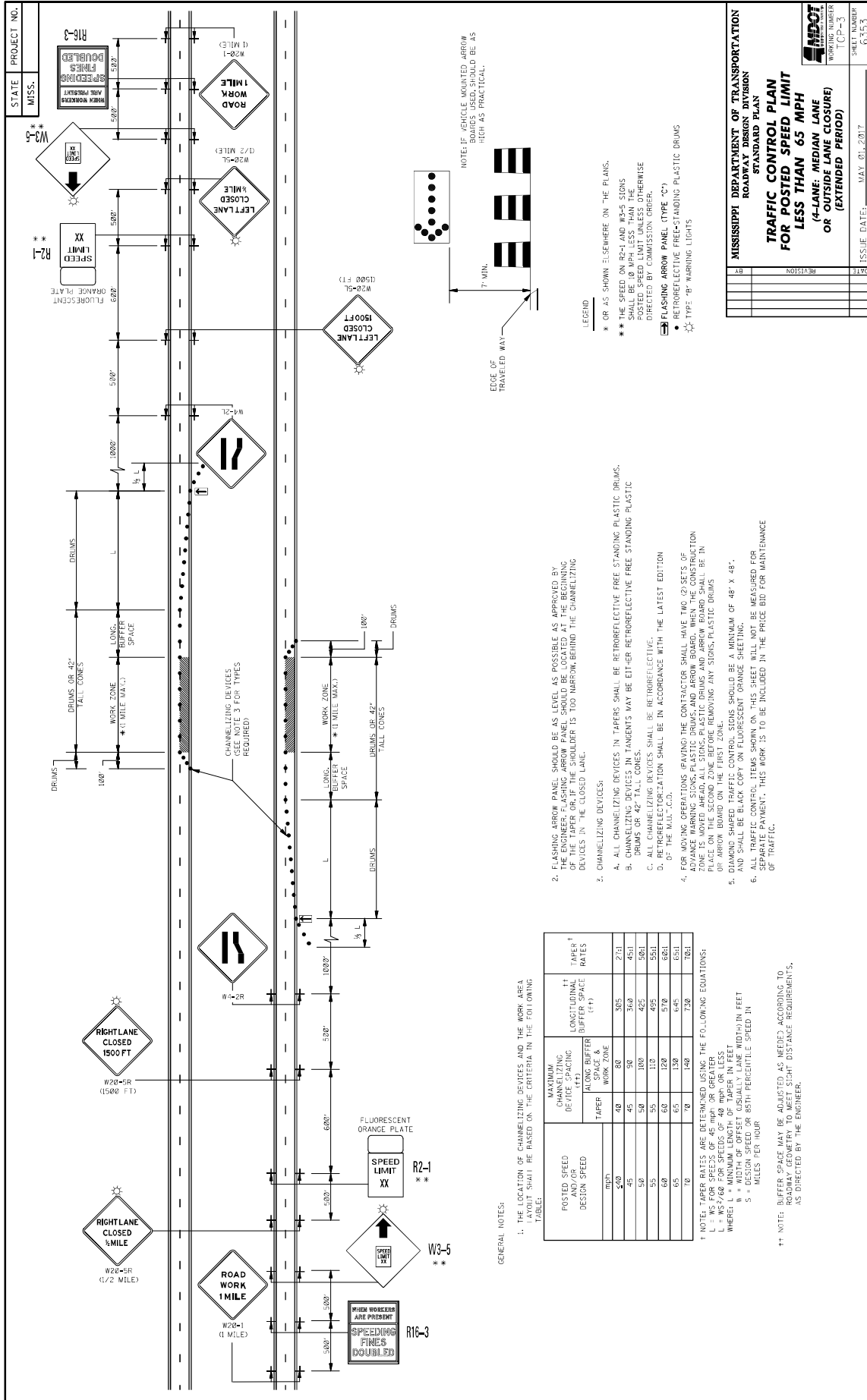

STATE PROJECT NO.
MISS. R16-3

ISSUE DATE: MAY 20, 2012

GENERAL NOTES:

- THE LOCATION OF CHANNELIZING DEVICES AND THE WORK AREA LENGTH SHALL BE BASED ON THE CRITERIA IN THE FOLLOWING TABLE:

POSTED SPEED AND/OR DEVISION (SPEED)	MAXIMUM CHANNELIZING DEVICE SPACING ALONG BUFFER SPACE & WORK ZONE (AFLK)	LONGITUDINAL BUFFER SPACE (FT)	TAPER RATES (PERCENT)
50*	40	80	30S 27/1
45	45	80	30S 26/1
40	50	100	30S 25/1
35	55	120	30S 24/1
30	60	150	30S 23/1
25	70	200	30S 22/1
20	80	250	30S 21/1
15	100	350	30S 20/1
10	150	500	30S 19/1
5	200	700	30S 18/1

* NOTE: TAPER RATES ARE DETERMINED USING THE FOLLOWING EQUATIONS:
 T = WS²/400 FOR SPEEDS OF 45 MPH OR GREATER
 L = WS/2 FOR SPEEDS OF 40 MPH OR LESS
 WHERE: L = MINIMUM BUFFER SPACE IN FEET
 S = DESIGN SPEED OR 85TH PERCENTILE SPEED IN MILES PER HOUR

** NOTE: BUFFER SPACE MAY BE ADJUSTED AS NEEDED ACCORDING TO ROADWAY GEOMETRY TO MEET SIGHT DISTANCE REQUIREMENTS, AS DIRECTED BY THE ENGINEER.

- FLASHING ARROW PANEL SHOULD BE AS LEVEL AS POSSIBLE AS APPROVED BY THE ENGINEER. FLASHING ARROW PANEL SHOULD BE LOCATED AT THE BEGINNING OF THE TAPER OR THE END OF THE TAPER, WITH A MINIMUM OF 100 FEET BEHIND THE CHANNELIZING DEVICES IN THE CLOSED LANE.

LEGEND

- * OR AS SHOWN ELSEWHERE ON THE PLANS.
- FLASHING ARROW PANEL (TYPE "C")
- BLACK, LEGGED AND BORDER ON WHITE BACKGROUND
- TYPE "B" MARKING LIGHTS
- RETROREFLECTIVE FREE-STANDING PLASTIC DRUMS

MISSISSIPPI DEPARTMENT OF TRANSPORTATION
ROADWAY DESIGN DIVISION
TRAFFIC CONTROL PLAN
FOR POSTED SPEED LIMIT
OF 65 OR 70 MPH
(INTERSTATES AND OTHER 4-LANE
DIVIDED HIGHWAYS)
(MEDIUM LANE OR OUTSIDE
LANE CLOSED (EXTENDED PERIOD))

REVISION: _____ DATE: _____

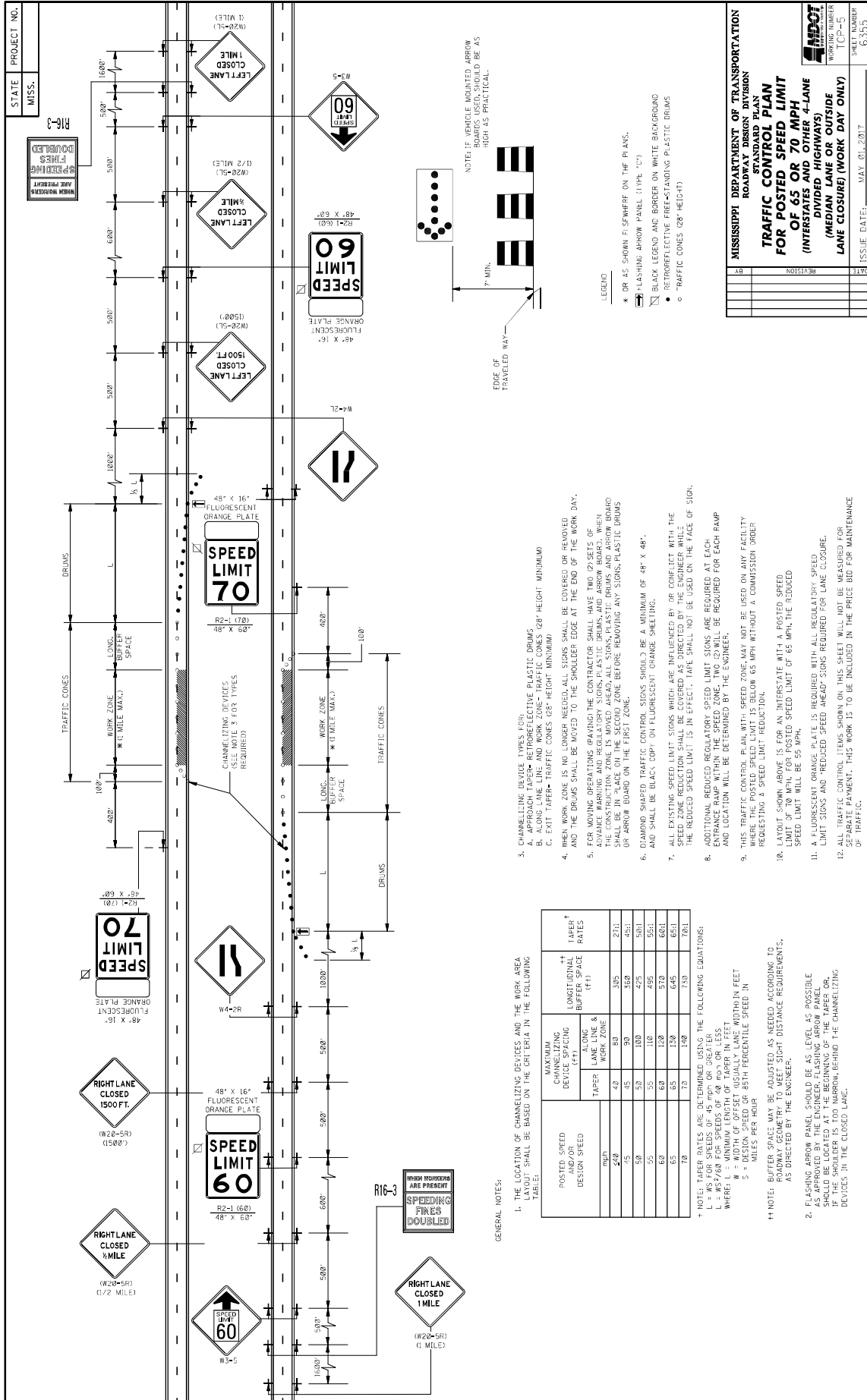

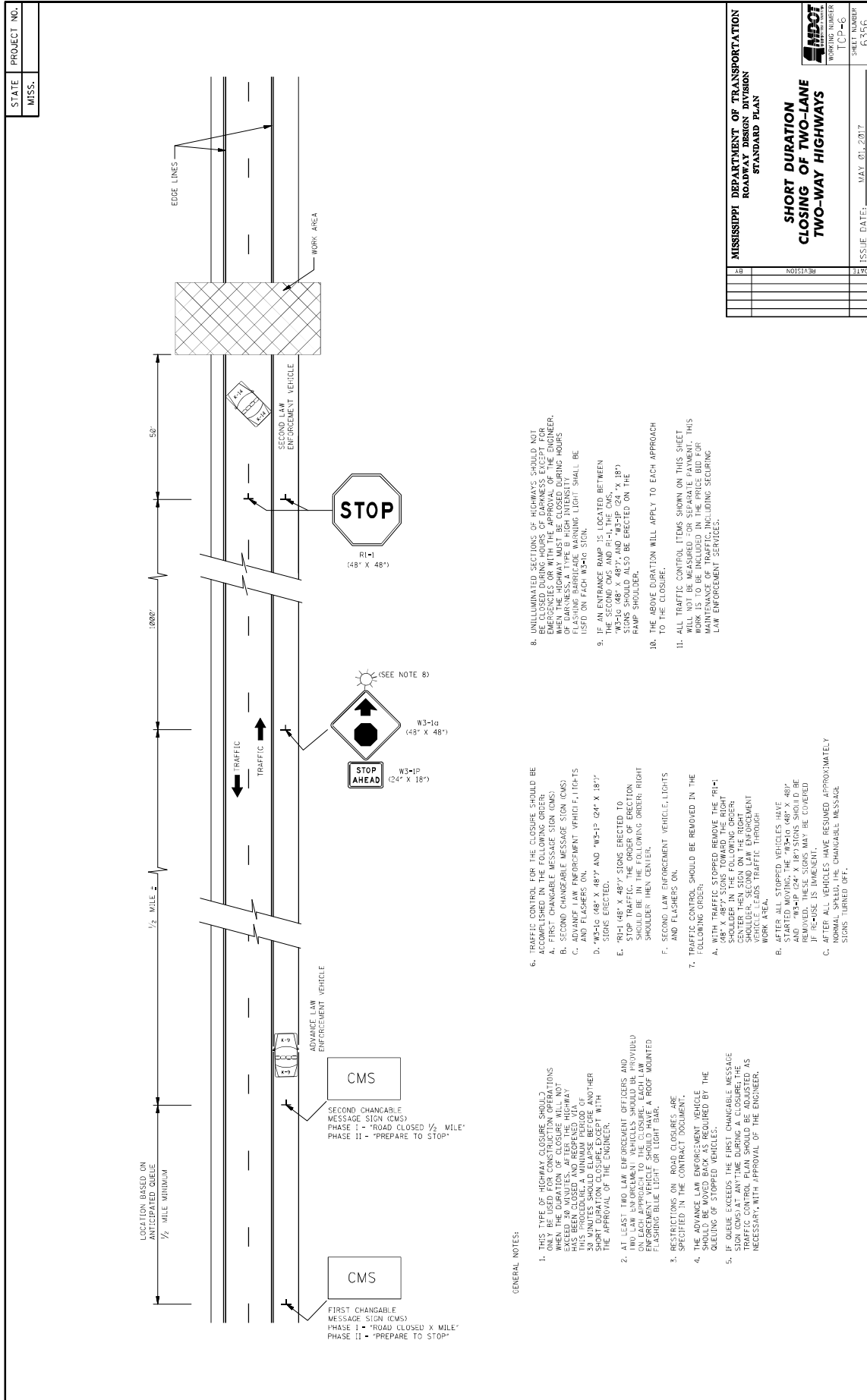

GENERAL NOTES:

- THIS TYPE OF HIGHWAY CLOSURE SHOULD BE USED ONLY FOR SHORT DURATION CLOSURES WHEN THE DURATION OF CLOSURE WILL NOT EXCEED 30 MINUTES. AFTER THE HIGHWAY IS CLOSED, THE ADVANCE LAW ENFORCEMENT VEHICLE SHOULD ELAPSE BEFORE ANOTHER ADVANCE LAW ENFORCEMENT VEHICLE WITH APPROVAL OF THE ENGINEER.
- AT LEAST TWO LAW ENFORCEMENT OFFICERS AND ONE ADVANCE LAW ENFORCEMENT VEHICLE ON EACH APPROACH TO THE CLOSURE. EACH LAW ENFORCEMENT VEHICLE SHOULD HAVE A ROOF MOUNTED FLASHING BLUE LIGHT ON LIGHT BAR.
- RESTRICTIONS ON ROAD CLOSURES ARE SPECIFIED IN THE CONTRACT DOCUMENT.
- THE ADVANCE LAW ENFORCEMENT VEHICLE SHOULD BE POSITIONED BY THE QUEUING OF STOPPED VEHICLES.
- IF QUEUE EXCEEDS THE FIRST CHANGABLE MESSAGE SIGN (CMS) AT ANYTIME DURING A CLOSURE, THE TRAFFIC CONTROL PLAN SHOULD BE ADJUSTED AS NECESSARY, WITH APPROVAL OF THE ENGINEER.
- TRAFFIC CONTROL FOR THE CLOSURE SHOULD BE ACCOMPLISHED IN THE FOLLOWING ORDER:
 - FIRST CHANGABLE MESSAGE SIGN (CMS)
 - SECOND CHANGABLE MESSAGE SIGN (CMS)
 - ADVANCE LAW ENFORCEMENT VEHICLE (S)
 - "W3-1a (48" X 48") AND "W3-1P (24" X 18") SIGNS ERECTED.
 - "R1-1 (48" X 48") SIGNS ERECTED TO STOP TRAFFIC. THE ORDER OF ERECTION SHOULD BE IN THE FOLLOWING ORDER: RIGHT SHOULDER THEN CENTER.
 - SECOND LAW ENFORCEMENT VEHICLE, LIGHTS AND FLASHERS ON.
- TRAFFIC CONTROL SHOULD BE REMOVED IN THE FOLLOWING ORDER:
 - WITH TRAFFIC STOPPED REMOVE THE "R1-1 (48" X 48") SIGNS TOWARD THE RIGHT SHOULDER THEN SIGN ON THE RIGHT SHOULDER. SECOND LAW ENFORCEMENT VEHICLE ADDS TRAFFIC THROUGH WORK AREA.
 - AFTER ALL STOPPED VEHICLES HAVE STARTED MOVING, THE "W3-1a (48" X 48") AND "W3-1P (24" X 18") SIGNS SHOULD BE REMOVED. TRAFFIC SHOULD BE COVERED IF ROAD IS WIDE ENOUGH TO BE COVERED.
 - AFTER ALL VEHICLES HAVE RESUMED APPROXIMATELY NORMAL SPEED, THE CHANGABLE MESSAGE SIGNS TURNED OFF.
- IF AN ENTRANCE RAMP IS LOCATED BETWEEN THE CLOSURE AND THE NEXT APPROACH, "W3-1a (48" X 48") AND "W3-1P (24" X 18") SIGNS SHOULD ALSO BE ERECTED ON THE RAMP SHOULDER.
- THE ABOVE DURATION WILL APPLY TO EACH APPROACH TO THE CLOSURE.
- ALL TRAFFIC CONTROL ITEMS SHOWN ON THIS SHEET WILL NOT BE MEASURED FOR SEPARATE PAYMENT. THIS WORK IS TO BE INCLUDED IN THE PRICE BID FOR MAINTENANCE AND CONSTRUCTION INCLUDING SECURING LAW ENFORCEMENT SERVICES.

MISSISSIPPI DEPARTMENT OF TRANSPORTATION ROADWAY DESIGN DIVISION STANDARD PLAN	
SHORT DURATION CLOSING OF TWO-LANE TWO-WAY HIGHWAYS	
ISSUE DATE:	MAY 01, 2017
SHEET NUMBER	6356
WORKING NUMBER	TCP-46
REVISION	

STATE PROJECT NO.
MISS.

WORKING NUMBER
ICP-5
SHEET NUMBER
03500

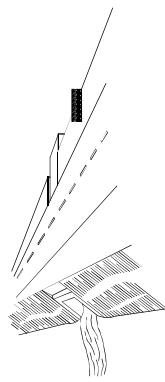
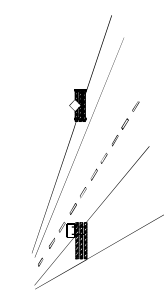
WING BARRICADES

1. WING BARRICADES ARE TYPE II BARRICADES ERECTED ON THE SHOULDER OF A ROADWAY OR RESTRICTED ROADWAY. WING BARRICADES MAY BE USED AS A MOUNTING FOR THE ADVANCE WARNING SIGNS OR FLASHERS.

2. WING BARRICADES SHOULD BE USED:

- IN ADVANCE OF A CONSTRUCTION PROJECT EVEN WHEN NO PART OF THE ROADWAY IS ACTUALLY CLOSED.
- IN ADVANCE OF ALL BRIDGE OR CULVERT WIDENING OPERATIONS.

BARRICADE CLOSING A ROAD

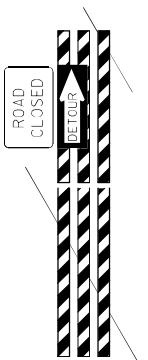

BARRICADE CHARACTERISTICS

	I	II	III
WIDTH OF RAIL **	8" MIN. - 12" MAX.	8" MIN. - 12" MAX.	8" MIN. - 12" MAX.
LENGTH OF RAIL **	24" MIN.	24" MIN.	48" MIN.
WIDTH OF STRIPE *	6"	6"	6"
HEIGHT	36" MIN.	36" MIN.	60" MIN.
NUMBER OF RETROREFLECTORIZED RAIL FACES	2 (ONE EACH DIRECTION)	4 (TWO EACH DIRECTION)	3 IF FACING TRAFFIC IN ONE DIRECTION 4 IF FACING TRAFFIC IN TWO DIRECTIONS

STANDARD BARRICADES

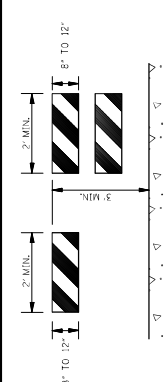
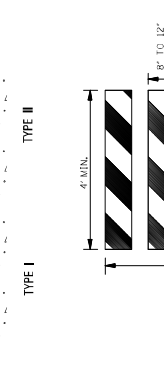
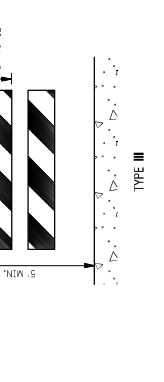
1. THE MARKING FOR BARRICADE RAILS SHALL BE ORANGE AND WHITE (SLOPING DOWNWARD AT AN ANGLE OF 45° IN THE DIRECTION OF TRAFFIC IS TO PASS).

2. RAIL STRIPE SHALL BE 6 INCHES EXCEPT THAT 4-INCH WIDE STRIPES MAY BE USED IF RAIL LENGTHS ARE LESS THAN 36 INCHES.

3. DO NOT PLACE SANDBAGS OR OTHER DEVICES TO PROVIDE MASS ON THE BOTTOM RAIL THAT WILL BLOCK VIEW OR RAIL FACE.

4. FOR ADDITIONAL INFORMATION OR DETAILS, SEE METHOD, LATEST EDITION.

5. BARRICADES ARE CLASSIFIED BY FHWA AS CATEGORY II WHEN ZONE DEVICES WHICH REQUIRE SUCCESSFULLY CRASH TESTED. A LIST OF CRASHWORTHY BARRICADES AND OTHER CATEGORY II DEVICES CAN BE FOUND ON FHWA'S WEBSITE: http://safety.fhwa.dot.gov/roadway_dept/pafety_guidance/road_hardware/cat2.cfm

CHEVRON SIGN DETAIL

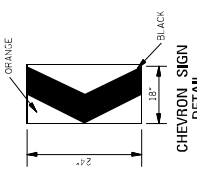

1. A CHEVRON SIGN CONSISTS OF A BLACK CHEVRON TYPE MARKING ON AN ORANGE BACKGROUND AND SHALL POINT IN THE DIRECTION OF TRAFFIC FLOW.

2. THE CHEVRON SIGN SHALL BE MOUNTED ON CRASHWORTHY SUPPORT.

3. CHEVRON SIGNS MAY BE USED TO SUPPLEMENT OTHER STANDARD DEVICES WHERE ONE OR MORE LANES ARE CLOSED FOR CONSTRUCTION OR MAINTENANCE. THEY SHOULD BE PLACED APPROXIMATELY 2' 40" BEHIND THE LANE TRANSITION STRIPE.

TYPE 3 OBJECT MARKER (OM-3R)

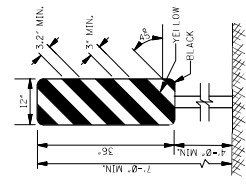

1. TYPE 3 OBJECT MARKERS SHALL BE USED AT ALL EXPOSED BRIDGE ABUTMENTS AND AT OTHER LOCATIONS AS DETERMINED NECESSARY BY THE ENGINEER.

2. THE OM-3R IS SIMILAR EXCEPT THE STRIPES SLOPE DOWNWARD FROM THE UPPER LEFT SIDE TO THE LOWER RIGHT SIDE AND SHALL BE PLACED ON THE LEFT SIDE OF THE OBJECT.

3. THE INSIDE EDGE OF THE MARKER SHALL BE IN LINE WITH THE INNER EDGE OF THE OBSTRUCTION.

PLASTIC DRUM STRIPING DETAIL

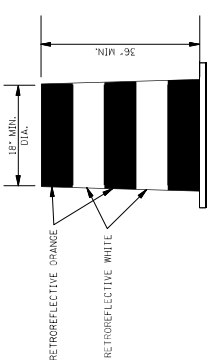

1. PLASTIC DRUMS SHALL BE ON END AND USED AS AN EXPEDIENT METHOD FOR TRAFFIC CHANNELIZATION. THE COLOR AND MARKING OF DRUMS SHALL BE CONSISTENT WITH MARKING STRIPING. THE PREFERRED COLOR OF DRUMS WITH MARKING STRIPING IS ORANGE WITH POLYESTER-RETROREFLECTIVE, HORIZONTAL, CIRCUMFERENTIAL STRIPES (2 ORANGE & 2 WHITE) 6" WIDE.

2. DRUMS SHOULD NEVER BE PLACED IN THE ROADWAY WITHOUT WARNING SIGNS.

3. WHERE PRACTICAL PLASTIC DRUMS SHOULD BE PLACED NO CLOSER THAN 3'-0" FROM THE EDGE OF TRAVELED LANE.

MISSISSIPPI DEPARTMENT OF TRANSPORTATION
ROADWAY DESIGN DIVISION
STANDARD PLAN
HIGHWAY SIGN AND BARRICADE DETAILS FOR CONSTRUCTION PROJECTS

REVISION

DATE

ISSUE DATE: MAY 20, 2017

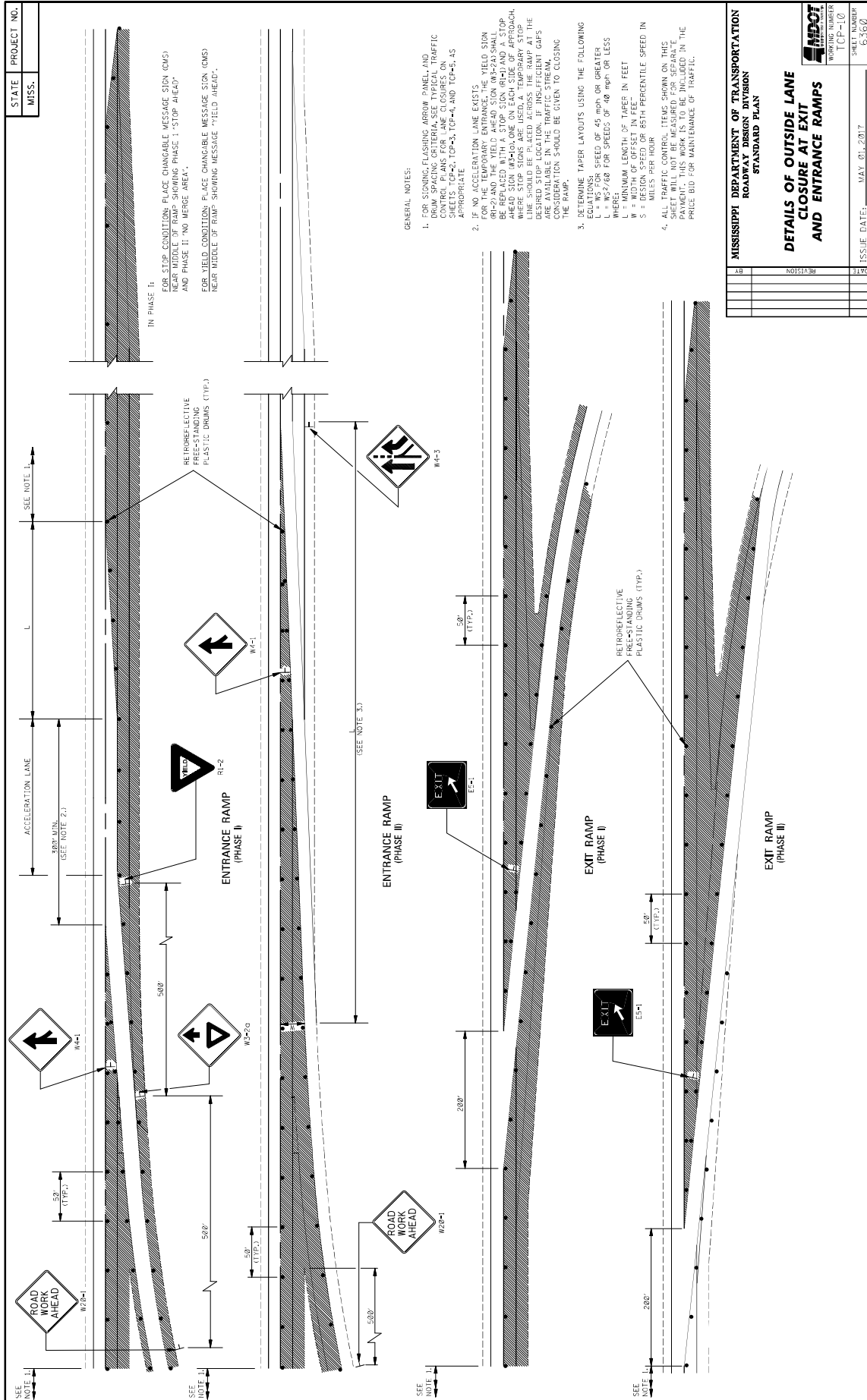

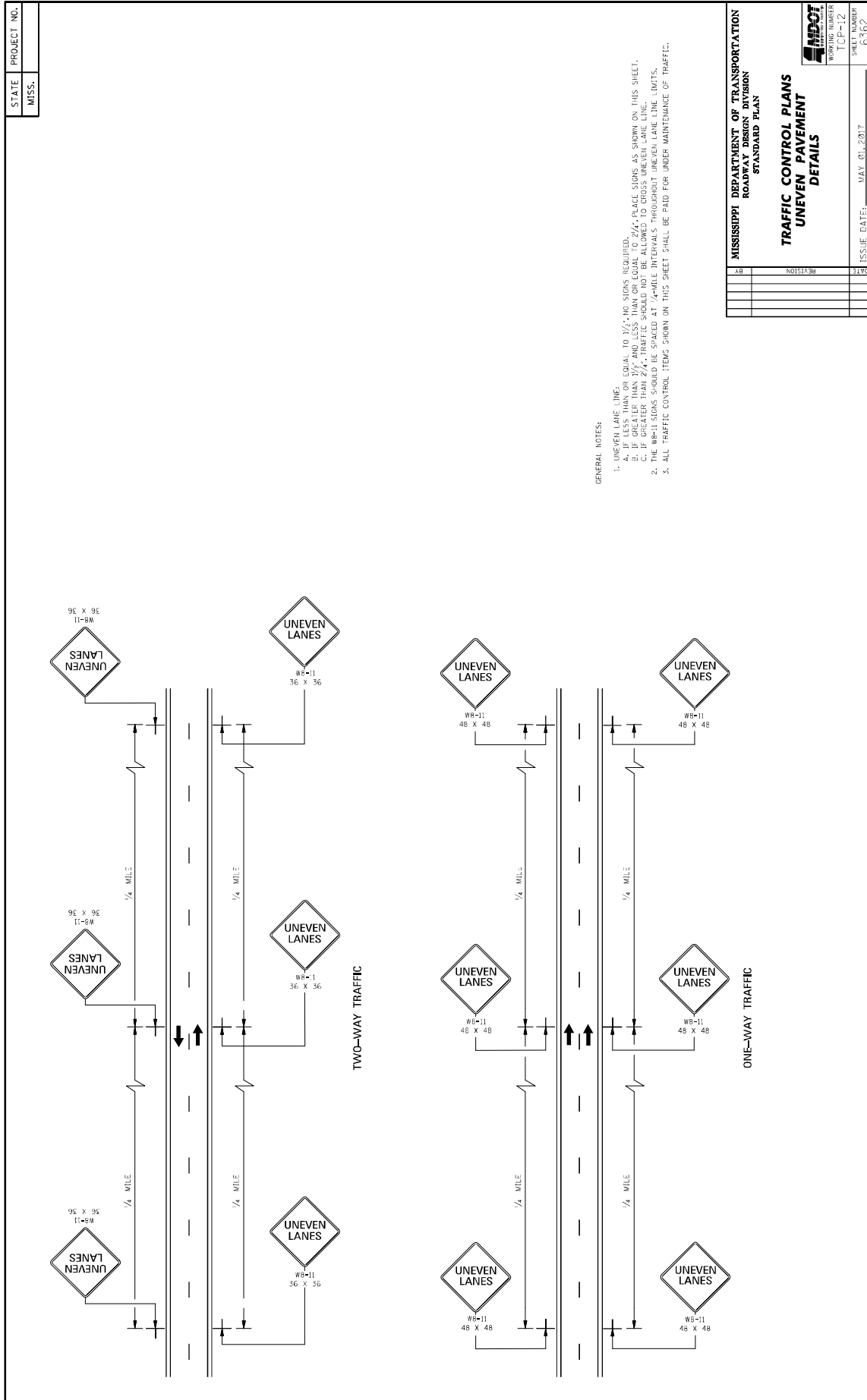

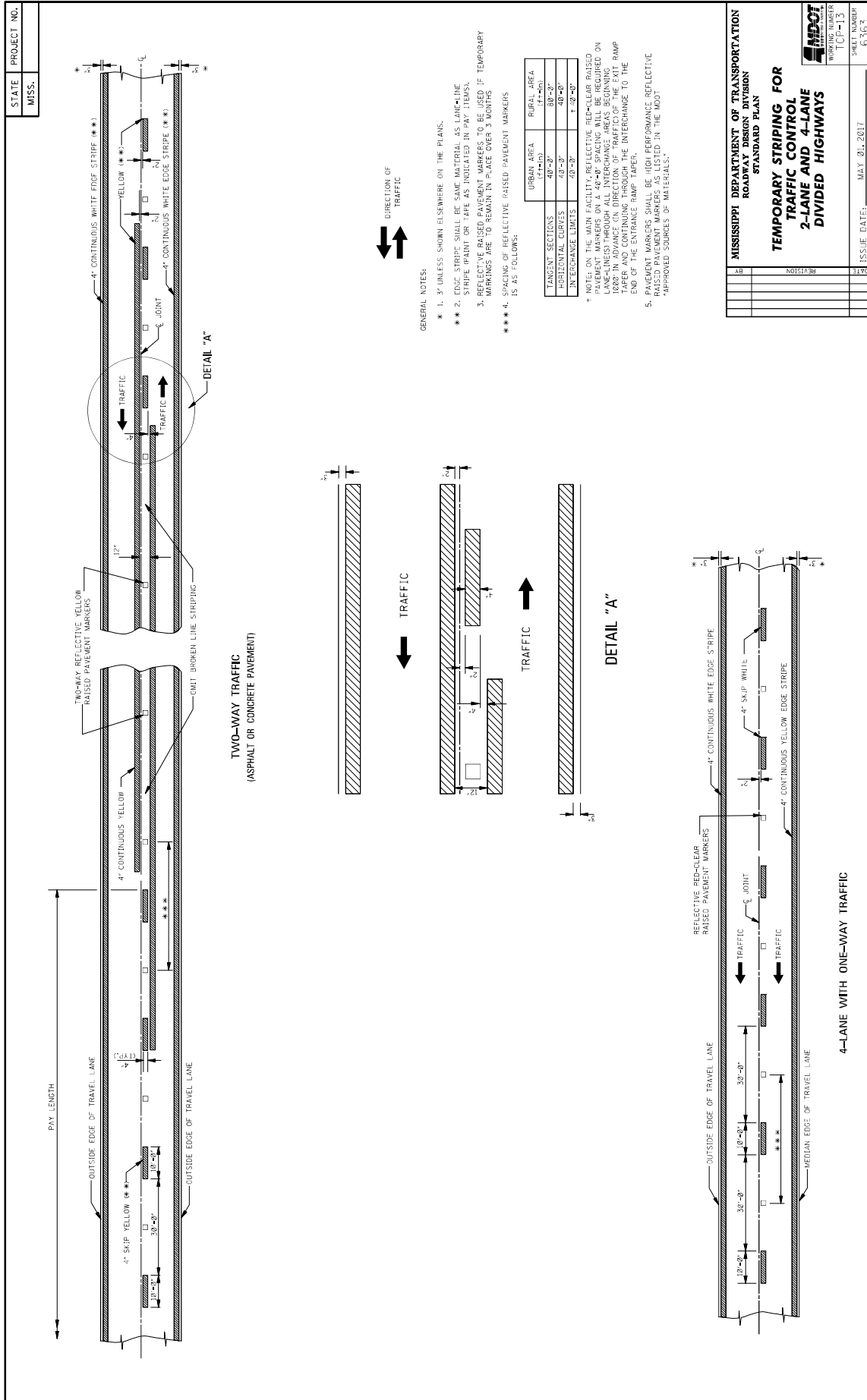

MISSISSIPPI DEPARTMENT OF TRANSPORTATION	
ROADWAY DESIGN DIVISION	
STANDARD PLAN	
TEMPORARY STRIPING FOR	
2-LANE AND 4-LANE	
DIVIDED HIGHWAYS	
WORKING NUMBER [CP-13]	SHEET NUMBER 6363
DATE	ISSUE DATE: MAY 01, 2017
REVISION	

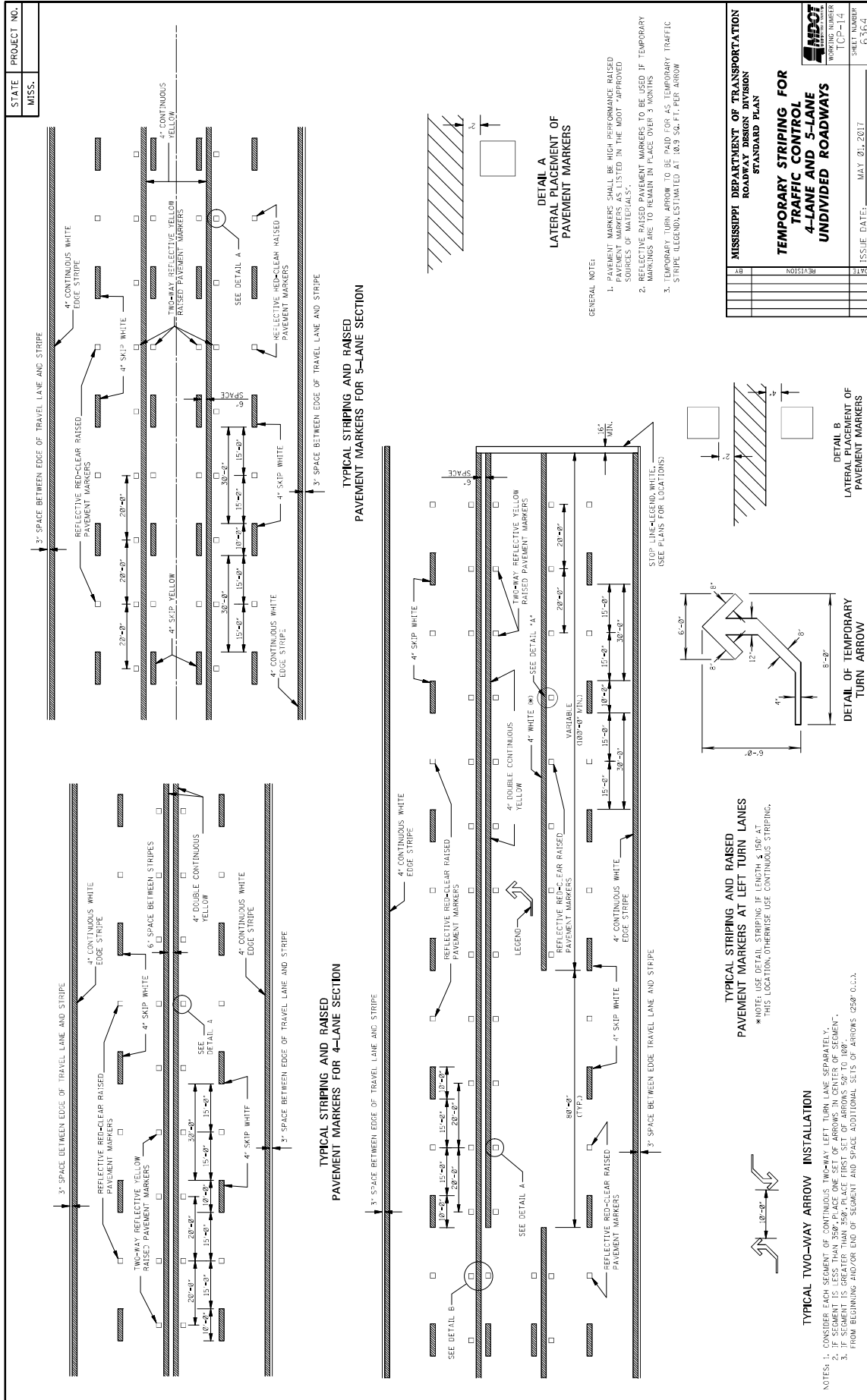

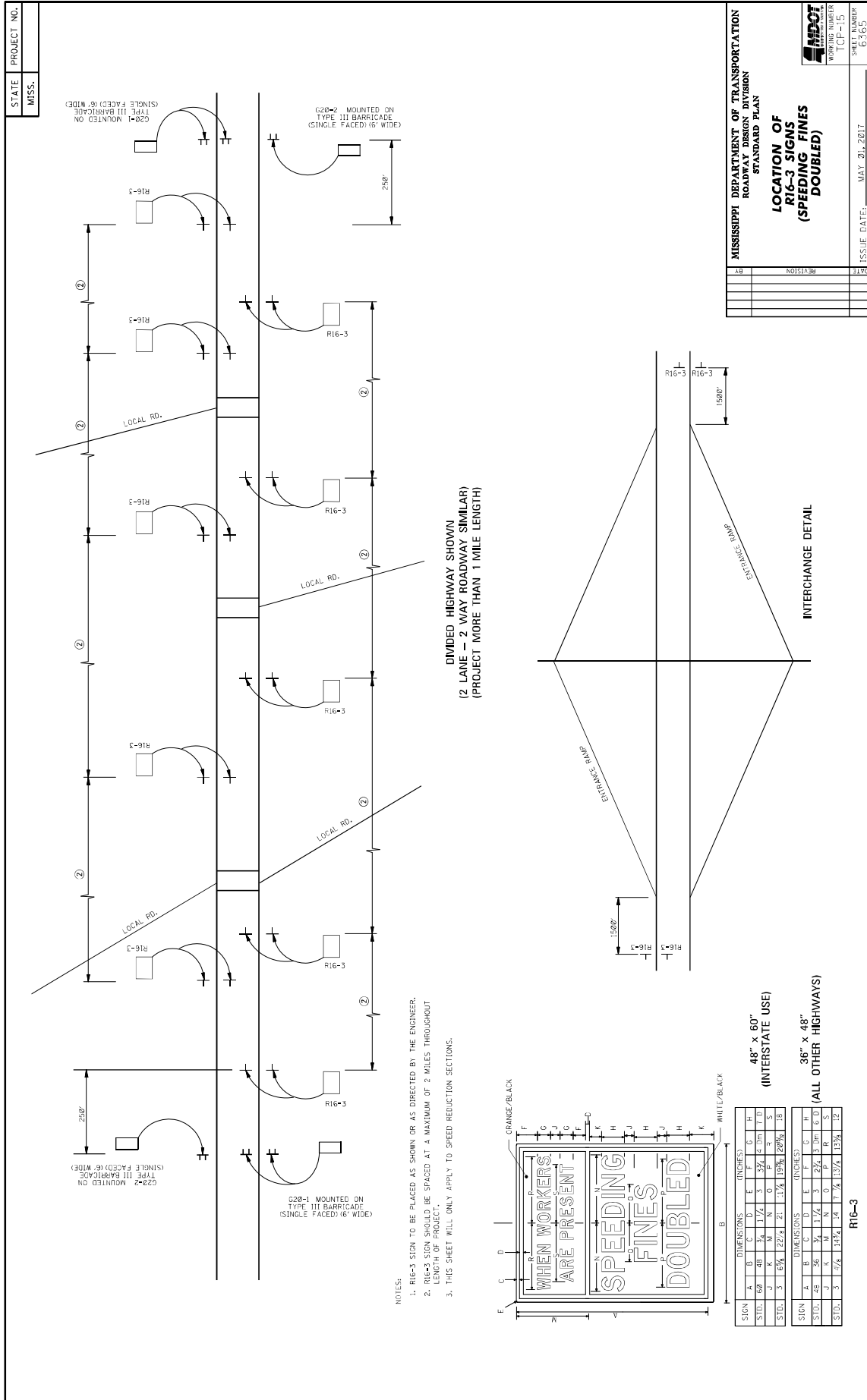

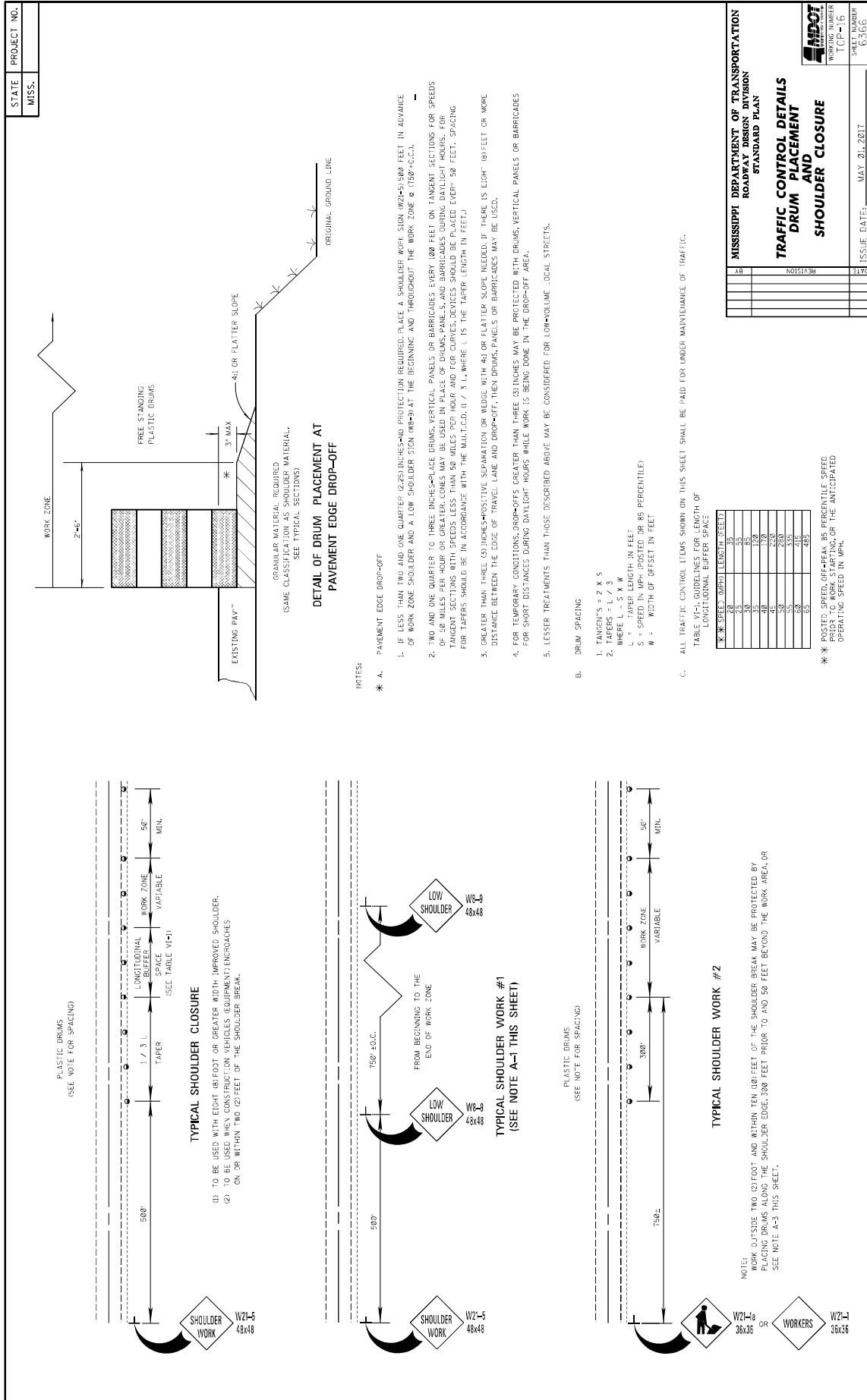

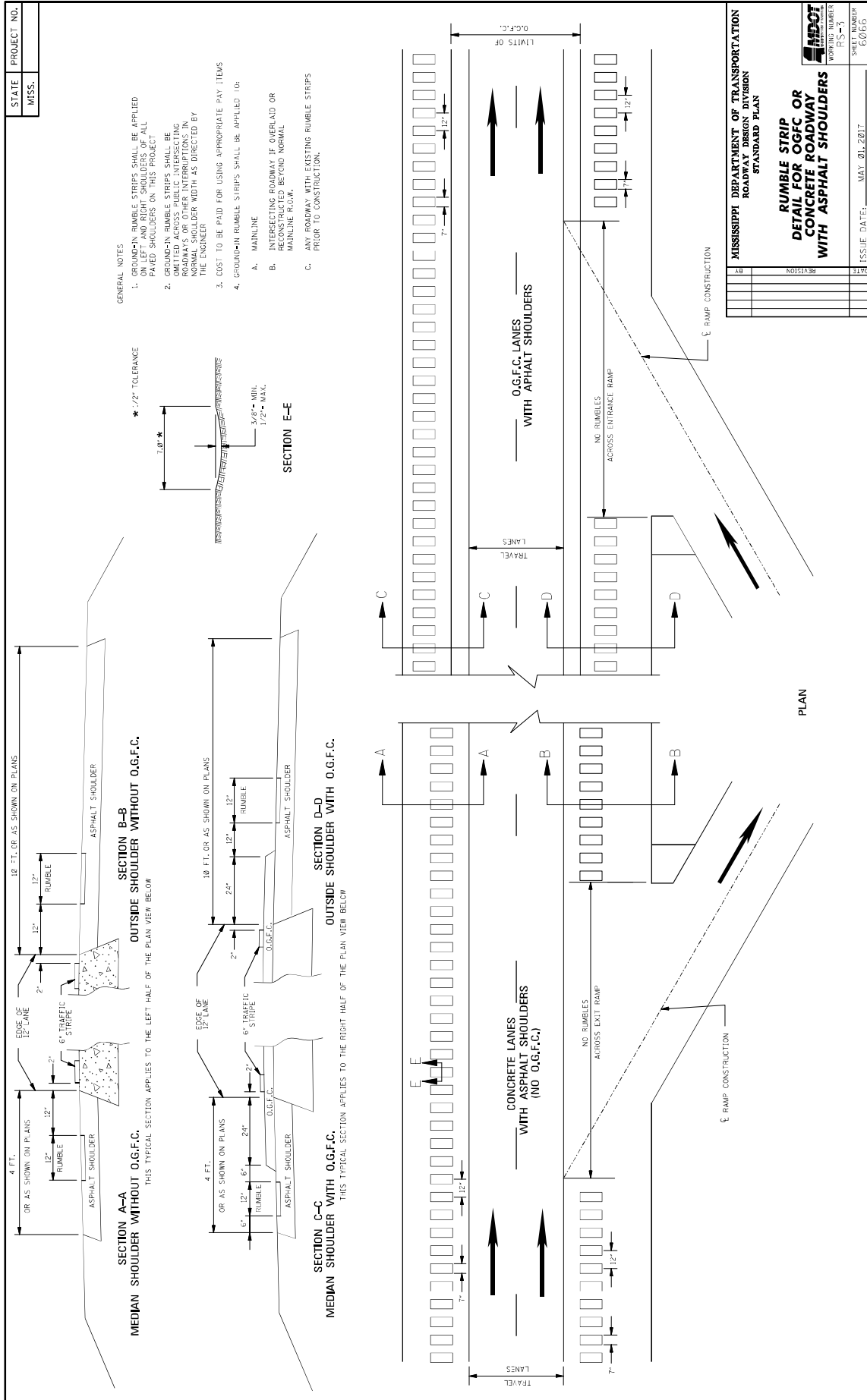

MISSISSIPPI DEPARTMENT OF TRANSPORTATION

SECTION 904 - NOTICE TO BIDDERS NO. 4702

CODE: (SP)

DATE: 11/22/2022

SUBJECT: App for Traffic Control Reports

Bidders are advised that the Department has created a smart phone App for completing and submitting traffic control reports (Form CSD-762) required on this project. The Contractor who monitors traffic control activities and completes traffic control reports will be required to download and use this App when completing and submitting traffic control reports. The reports will then be readily available to all persons who need access to the forms. The App is free and is available for downloading at the following location.

<https://extacctmgmt.mdot.state.ms.us/>

MISSISSIPPI DEPARTMENT OF TRANSPORTATION

SECTION 904 - NOTICE TO BIDDERS NO. 5086

CODE: (SP)

DATE: 05/02/2023

SUBJECT: Detail of Square Tube Sign Posts

Bidders are advised that the following drawings shall be used in the manufacture and installation of square tube sign posts, unless otherwise directed by the Engineer.

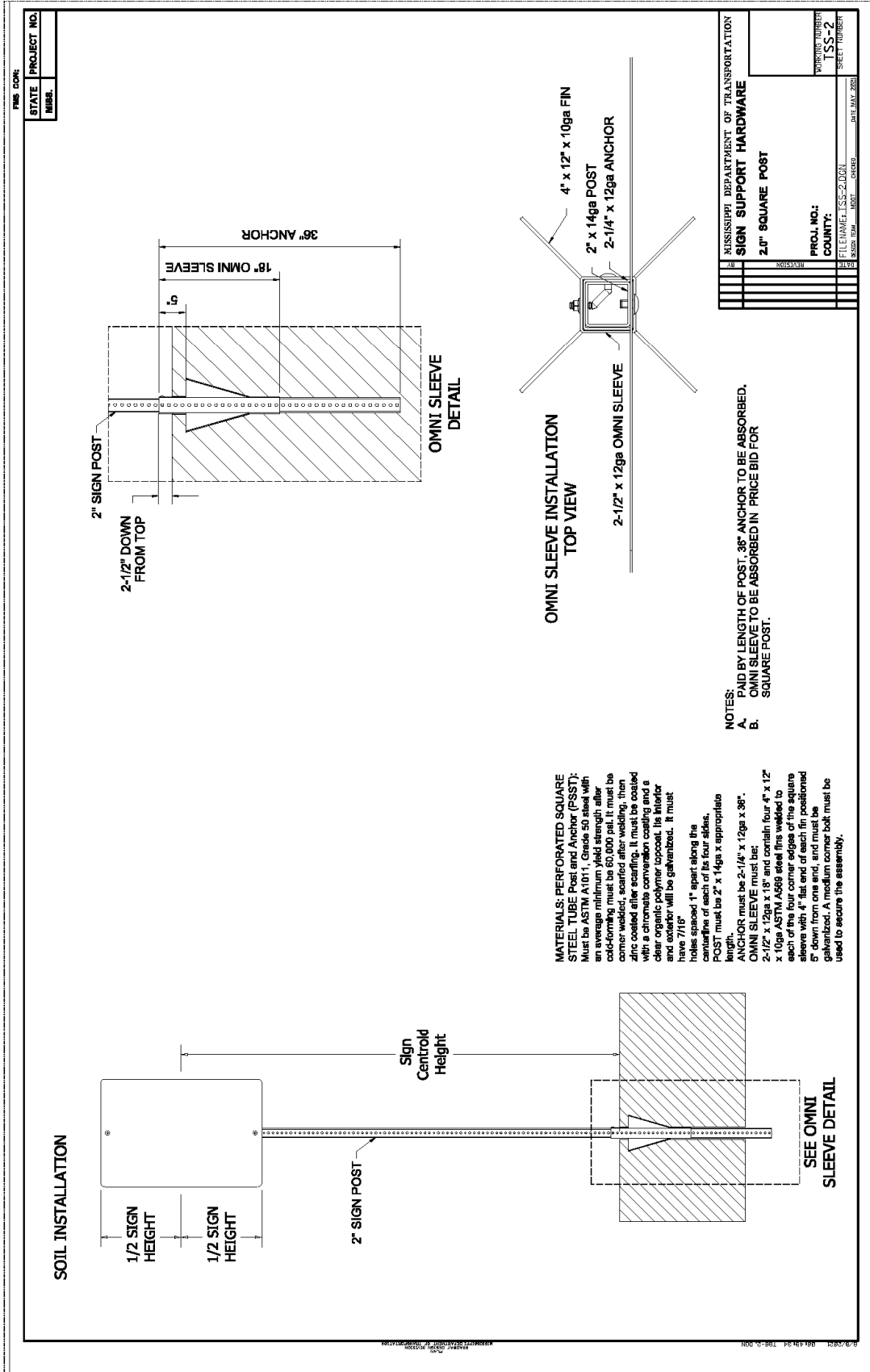

FMS CON:	STATE PROJECT NO.				
	MISS.				

SIGN CLAMP KIT

min. depth is 54 in.
min. db. is 18 in.

VARIES PER PLANS AND LOCATIONS

grade

7" height to grade

SIGN POSTS

4-1/2" x 54" x 7 GA
UNIBASE ANCHOR
AS90 GRADE 8 TUBE
WELDED TO 1"
THICK A572 SLIP
PLATE GALVANIZED
PER ASTM A563.

SIGN CLAMP KIT

MATERIALS: 2" WIDE x 3/4" TYPE 304, A286 FINISHED STAINLESS STEEL BRACKET. INCLUDES 2 STAINLESS THREADED BOLTS AND SERRATED FLANGED NUTS. ONE CLAMP REQUIRED FOR EACH BRACE TO POST JUNCTION.

7/8"

3 1/2"

4.91"

SIGN POSTS

STEEL CONFORMS TO ASTM A563, Grade C. MUST BE WELDED, SCARFED OUTSIDE AFTER WELDING, THEN ZINC FLOCCED AND COATED WITH POLYURETHANE EXTERIOR AFTER SCARFING. MUST BE COATED WITH A CROMATE CONVERSION COATING & CLEAR ORGANIC POLYMER TOPCOAT. POST WEIGHT IS 6.1 LB/LIN FT.

4"

54"

4-1/2"

UNIBASE ANCHOR STUB

1 1/2"

54"

4-1/2"

SLIP BASE ASSEMBLY

1 1/2"

2"

4" SQUARE POST RECEIVER

4"

1 1/2"

13"

13"

Ø9"

4" SQUARE POST RECEIVER

4"

1 1/2"

3 1/4"

3/4"

6"

2 1/2"

13" OMNIDIRECTIONAL SLIP BASE RECEIVER FOR 4" SQUARE POST. ALSO USE THE HARD TO 1" THICK A572 SLIP PLATE GALVANIZED PER ASTM A563.

POST ATTACHMENT HARDWARE KIT WILL CONSIST OF:
 (3) 5/8"-11 x 5-3/4" HEX BOLTS - A325
 (3) 5/8" x 4-3/4" A307 WASHER
 (3) 5/8" x 4-3/8" A307 WASHER - F438
 (3) 5/8" HEX NUTS - A308D8
 ALL NOT DIF GALVANIZED per ASTM A153 F2224.
 NOTE: 1 POST ATTACHMENT HARDWARE KIT IS USED FOR SLIP BASE TOP POST RECEIVER.
 TORQUE TO 100 FT-LBS.

MISSISSIPPI DEPARTMENT OF TRANSPORTATION
SIGN SUPPORT HARDWARE
 4" SQUARE POST (SINGLE POST)
 PROJ. NO.:
 COUNTY:
 FILE NAME: JSS-3.DGN
 DATE: MAY 2001

NOTES:
 A. CONCRETE FOOTING MUST BE A MINIMUM OF 18" DIAMETER x 54" DEEP.
 B. BRASS SHIMS MAY BE USED BETWEEN SLIP PLATES TO LEVEL THE UPPER SLIP PLANE.
 C. MAXIMUM SIGN AREA PER SIGN BRACKET TO POST JUNCTION IS 10 FT².

MISSISSIPPI DEPARTMENT OF TRANSPORTATION

SECTION 904 - NOTICE TO BIDDERS NO. 5133

CODE: (SP)

DATE: 06/05/2023

SUBJECT: Contract Time

**PROJECT: SP-0835-00(006) / 109224301& SP-0835-00(007) / 109224302
Coahoma & Quitman Counties**

The completion of work to be performed by the Contractor for this project will not be a specified date but shall be when all allowable working days are assessed, or any extension thereto as provided in Subsection 108.06. It is anticipated that the Notice of Award will be issued no later than **August 08, 2023**.

The Contractor shall request a Notice to Proceed/Beginning of Contract Time date between the dates of **September 07, 2023 and March 14, 2024**.

Should the Contractor request a Notice to Proceed earlier than **September 07, 2023** and it is agreeable with the Department for an early Notice to Proceed, the requested date will become the new Notice to Proceed and Beginning of Contract Time date.

Should the Contractor not request a Notice to Proceed by **March 14, 2024**, the date for the Notice to Proceed and Beginning of Contract Time will be **March 14, 2024**.

All requests for an early Notice to Proceed shall be sent to the Project Engineer who will forward it to the Contract Administration Division.

105 Working Days have been allowed for the completion of work on this project.

The progress schedule for this project shows the Notice to Proceed and Beginning of Contract Time starting at the latest possible date. If the Contractor requests a Notice to Proceed earlier than this date, the Contractor shall submit a revised progress schedule showing the work beginning at the new Notice to Proceed and Beginning of Contract Time date.

MISSISSIPPI DEPARTMENT OF TRANSPORTATION

SECTION 904 - NOTICE TO BIDDERS NO. 5134

CODE: (SP)

DATE: 05/22/2023

SUBJECT: Scope of Work

**PROJECT: SP-0835-00(006) / 109224301 & SP-0835-00(007) / 109224302
Coahoma & Quitman Counties**

The contract documents do not include an official set of construction plans but may, by reference; include some Standard Drawings when so specified in a Notice to Bidders entitled, "Standard Drawings".

The work to be accomplished using the pay items and corresponding specifications set forth in this contract is for the full depth reclamation and double bituminous surface treatment of State Route 316 beginning at the Begin State Maintenance at Jonestown and going easterly for approximately 10 miles to MS 6/US 278 in Coahoma and Quitman Counties.

Termini:

Coahoma County:

Begin State Maintenance (MP:12.623) to Quitman County Line (MP:16.737) (4.11 Miles)

Quitman County:

Coahoma County Line (MP:0.000) to MS 6/US 278 (MP:6.041) (6.04 Miles)

It shall be the responsibility of the Contractor to protect the roadway and all existing structures, such as bridges, and curb from damage occurring as a result of the Contractor's operations. Damages to existing features caused by the Contractor's operations shall be repaired or replaced at no cost to the Department.

At bridge ends and at the end of work day, a taper of one vertical inch (1") for each three horizontal feet (3') shall be provided.

The Contractor shall make a utility location request to 811 prior to any excavation, except for trench widening or pavement removal/repair.

In order to expedite the safe movement of traffic and to protect each phase of the work as it is performed, a firm sequence of operations is essential. The work shall be begun and continually prosecuted.

The work shall consist of the following:

1. The Contractor will erect and maintain 40 mile per hour signs and gravel road signs throughout the project at one (1) mile alternating intervals. These signs will be absorbed in pay item 618-A: Maintenance of Traffic. The project shall be divided into five (5) sections. The roadway

will be closed to through traffic in one section at a time until reconstruction work is complete in that section. No more than one section can be closed at a time. Ingress and egress of local traffic will be allowed for destinations within a section of closed roadway. After all necessary work through the placement of at least a single seal course and temporary traffic stripe is completed to the satisfaction of the Engineer in a section, that section shall be reopened to traffic and work can begin in another section. Once a section of the project is reopened to traffic all traffic control standards for a two-lane roadway shall apply for all subsequent work.

Changeable message signs shall be in place at the approaches of each section seven (7) days prior and during the closure of the road. Type III barricades with ROAD CLOSED TO THRU TRAFFIC (R11-4) shall be provided at the termini of each section with the cost being included in pay item 618-A: Maintenance of Traffic

Section	Termini				Length
	From	MP/Station	To	MP/Station	Miles (Feet)
1	Jonestown	12.623 (20+00)	BR#6	14.310 (109+10)	1.69 (8,910)
2	BR#6	14.612 (125+00)	Quitman CL	16.737 (237+22)	2.13 (11,222)
3	Quitman CL	0.000 (0+00)	BR#9.8	1.534 (81+00)	1.53 (8,100)
4	BR# 9.8	1.856 (98+00)	Belen	3.433 (181+25)	1.58 (8,325)
5	Belen	3.921(207+00)	SR 6/US278	6.041 (319+44)	2.12 (11,244)

2. The Contractor shall pulverize and mix the sub-grade/asphalt according to Special Provision 907-424, Roadbed Reclamation. The mixing depth will be nine inches (9”) deep. The volume of cement to be mixed will be six percent (6%) by volume. The majority of the material to be mixed will be approximately four to six inches (4” to 6”) and variable of stripped asphalt and three inches (3”) of granular base. Traffic shall not be allowed on the reclamation area for a period of three (3) hours after final mixing and compaction. The total mixing width shall be twenty-four feet (24’) wide. The Contractor will have the option to seal the reclamation area by placing a curing seal with sand blotter material or keep the reclamation area damp at all times until the chip seal course is placed. The Contractor will open lanes up for two-way local traffic only at the end of each day.

The pulverized section shall be placed on grade and the required cross-slopes established prior to spreading of cement. The horizontal curves shall be placed on the proper cross slopes, as provided by the Department, with the pulverized material. The maximum amount of material to be moved shall not be more than three inches (3”) in depth.

NOTE: The following locations will be omitted from the full depth reclamation.

Coahoma County

Station 109+10 to Station 125+00 (1590 feet) (Bridge Replacement, BR#6)

Equation: Station 237+22 (Back, Coahoma County) = 0+00 (Ahead, Quitman County)

Quitman County

Station 81+00 to Station 98+00 (1700 feet) (Bridge Replacement, Br# 9.8)

Station 181+25 to Station 207+00 (2575 feet) (Belen)

NOTE: The following pipe crossings could be damaged during the reclamation process. The contractor is advised to field verify the depth of these pipes and adjust the mixing depth to prevent any damage at these locations.

Station #	Cover (feet)
Quitman County	
32+70	1.1
197+00	0.2
204+00	0.8
268+35	1.2
275+35	1.4
288+40	1.4

- Grade stakes and tolerances for the reclaimed roadbed will follow the specifications for Bases listed in Subsection 321.03.7.2.2 of the Standard Specifications. The Contractor will be required to profile the existing centerline prior to the pulverization of the roadbed. The existing centerline grade shall be established with an acceptable profile grade prior to placement of the chip seal. The reclaimed roadbed shall be reconstructed to a negative two percent (-2%) cross slope or the appropriate super elevation rate. The trimmed material will be allowed to be placed along the shoulders of the highway as long as it can be mixed, incorporated and graded to a negative four percent (-4%) cross slope or the appropriate slope in super elevated sections. The Contractor shall be required to maintain the centerline alignment of the existing roadway. The Contractor shall ensure the finished mixed roadbed will allow for a smooth tie in of the existing asphalt surface course at all project limit tie-ins. Construction staking shall be required on this project and shall be in accordance with Section 699, Construction Stakes.

Contractor shall utilize the proper surveying equipment that will ensure the grade control operations meet the acceptable tolerances for grade and cross-slopes. Grade stakes shall be set at 50-foot intervals in tangent sections and 25-foot intervals in curves.

- A double bituminous surface treatment shall be placed on the previous reclaimed base. All roadway surfaces shall be broomed before the placement of the CRS-2P material. The application rate of CRS-2P shall be per the table listed below or as directed by the Engineer depending on field conditions.

Seal aggregates shall be placed in accordance with the requirements specified in Section 410 of the Standard Specifications and per the table listed below or as directed by the Engineer depending on field conditions.

Application Rate			
Application	CRS-2P (gal/SY)	Cover Agg. (#7) (ft ³ /SY)	Cover Agg. (#89) (ft ³ /SY)
1 st Course	0.39 – 0.44	0.25 – 0.31	
2 nd Course	0.39 – 0.44		0.25 – 0.31

All traffic control needed for the chip seal work will be included in pay item 618-A: Maintenance of Traffic. The Contractor shall place temporary centerline strip and chip seal reflective raised markers at the end of each days run along the centerline of the highway. Costs of the chip seal reflective raised markers shall be included in pay item 618-A: Maintenance of Traffic.

A minimum of a single chip seal course shall be placed on the reclaimed roadbed within three (3) calendar days of mixing. The Contractor will be charged a fee of \$5,000.00 for each full or partial day in which the reclaimed roadbed area is left uncovered after the three (3) calendar days.

5. A single bituminous surface treatment shall be placed on the following sections:

Coahoma County

Station 109+10 to Station 125+00 (161 feet of bridge deck, not to be chipped sealed).

Quitman County

Station 81+00 to Station 98+00 (220 feet of bridge deck, not to be chipped sealed).

Station 181+25 to Station 207+00 (2575 feet) (Belen)

Application Rate	
CRS-2P (gal/SY)	Cover Agg. (#89) (ft ³ /SY)
0.39 – 0.44	0.25 – 0.31

6. Temporary traffic stripe shall be placed daily as per Section 618 of the Standard Specifications.
7. A fog seal shall be placed on the final chip sealed surface at a rate of 0.11 gal/sy, or as directed by the Engineer. The fog seal shall be placed within 72 hours after completion of the chip seal placement.
8. Permanent pavement markings (thermoplastic striping, two-way clear reflective high performance raised markers and two-way yellow reflective high performance raised markers) shall be placed as required.
9. All existing post mounted standard roadside signs shown in the attached tables shall be removed and replaced. Existing signs will become the property of the Department. Signs will be delivered to the maintenance shop located at 1799 Hwy 6 West in Marks. Signs shall be removed from the post prior to delivery to the Department. The signpost shall become the property of the Contractor. Signs on existing round pipe post will be replaced on the existing

post. The cost of the removal of the existing sign shall be absorbed in other items of work. The Contractor is required to verify the sign and post quantity prior to ordering material.

The Contractor shall provide all signs and traffic handling devices necessary to safely maintain traffic around or through the work areas.

Incidental work such as removing vegetation, shaping and compaction of shoulder, necessary and incidental grading of roadway ditches and other incidental work that is necessary to complete the work will not be measured for separate payment and the cost will be included in the bid items provided.

The Engineer may direct the use of additional cones at County Roads or Intersections within lane closures and will be absorbed in pay item 618-A: Maintenance of Traffic.

Coahoma County									
Location (Sta. #)	Lane Location	Sign Code	Sign Description	Type 3 Object Markers	0.08"	0.1"	0.125"	Square Tube Post (2#/LF)	Removal U-Channel
34+50	L	W1-3L	Curves Ahead				9	15	1
34+50	L	W13-1	35 mph caution		4				
42+50	R	W1-2R	Right Curve Ahead				9	15	1
42+50	R	W13-1	40 mph caution		4				
45+00	R	W2-2L	Side Road Lt.				9	15	
50+50	L	W3-1a	Stop Sign Ahead				9	15	1
50+50	R	W1-7	Lt./Rt. Arrow			8		15	
50+50	L	R1-1	36" Stop			7.46		15	1
55+50	L	W2-2R	Side Road Rt.				9	15	
56+25	L	W1-2L	Left Curve Ahead				9	15	1
56+25	L	W13-1	40 mph caution		4				
107+25	R	W8-13	Bridge May Ice				9	15	1
117+26	Both	OM-3L/R	Type 3 OM	2					2
118+67	Both	OM-3L/R	Type 3 OM	2					2
129+00	L	W8-13	Bridge May Ice				9	15	1
158+00	R	W2-2L	Side Road Lt.				9	15	
163+50	L	R1-1	36" Stop			7.46		15	1
163+50	R	W1-7	Lt./Rt. Arrow			8		15	
167+00	R	W2-2L	Side Road Lt.				9	15	
168+50	L	W2-2R	Side Road Rt.				9	15	
172+00	L	R1-1	36" Stop			7.46		15	1
172+00	R	W1-7	Lt./Rt. Arrow			8		15	
175+00	R	W2-2R	Side Road Rt.				9	15	1
177+00	L	W2-2R	Side Road Rt.				9	15	
180+00	R	R1-1	36" Stop			7.46		15	1
180+00	L	W1-7	Lt./Rt. Arrow			8		15	
184+00	L	W2-2L	Side Road Lt.				9	15	
185+00	L	W1-2R	Right Curve Ahead				9	15	1
186+00	R	W1-2L	Left Curve Ahead				9	15	1
186+00	R	W13-1	40 mph caution		4				
197+50	R	W2-2R	Side Road Rt.				9	15	1
201+50	L	W1-2R	Right Curve Ahead				9	15	1
204+00	R	W3-1a	Stop Sign Ahead				9	15	1
204+00	R	R1-1	36" Stop			7.46		15	1
204+00	L	W1-7	Lt./Rt. Arrow			8		15	
209+00	L	W2-2L	Side Road Lt.				9	15	
Totals				4	16	77.3	180	450	21

Quitman County									
Location (Sta. #)	Lane Location	Sign Code	Sign Description	Type 3 Object Markers	0.08"	0.1"	0.125"	Square Tube Post (2#/LF)	Removal U-Channel
40+25	R	W1-2R	Right Curve Ahead				9	15	1
45+00	R	W2-2L	Side Road Lt.				9	15	
50+50	L	R1-1	36" Stop			7.46		15	1
50+50	R	W1-7	Lt./Rt. Arrow			8		15	
55+00	L	W2-2R	Side Road Rt.				9	15	
60+00	L	W1-2L	Left Curve Ahead				9	15	1
68+00	R	W2-2L	Side Road Lt.				9	15	
73+50	L	R1-1	36" Stop			7.46		15	1
73+50	R	W1-7	Lt./Rt. Arrow			8		15	
78+00	R	W8-13	Bridge May Ice				9	15	
79+50	L	W2-2R	Side Road Rt.				9	15	1
87+50	Both	OM-3L/R	Type 3 OM	2					2
89+50	Both	OM-3L/R	Type 3 OM	2					2
101+00	L	W8-13	Bridge May Ice				9	15	1
107+50	R	W1-2R	Right Curve Ahead				9	15	1
107+50	R	W13-1	35 mph caution		4				
110+00	R	W2-2L	Side Road Lt.				9	15	1
115+00	L	R1-1	36" Stop			7.46		15	1
115+00	R	W1-7	Lt./Rt. Arrow			8		15	
117+50	L	R1-1	36" Stop			7.46		15	1
117+50	R	W1-7	Lt./Rt. Arrow			8		15	
123+00	L	W2-2R	Side Road Rt.				9	15	1
129+00	L	W1-2L	Left Curve Ahead				9	15	1
142+50	R	W1-2L	Left Curve Ahead				9	15	1
150+00	R	W2-2R	Side Road Rt.				9	15	
155+50	R	R1-1	36" Stop			7.46		15	1
155+50	L	W1-7	Lt./Rt. Arrow			8		15	
160+00	L	W2-2L	Side Road Lt.				9	15	
160+00	R	W3-5	45 mph speed zone ahead		5			15	1
162+75	L	W1-2R	Right Curve Ahead				9	15	1
163+25	R	W1-3R	Curves Ahead				9	15	1
168+00	R	R2-1	45 mph		5			15	1
168+00	L	R2-1	55 mph		5			15	1
173+50	R	R2-1	35 mph		5			15	1
173+50	L	R2-1	45 mph		5			15	1
180+25	R	W1-1R	Right Curve Ahead				9	15	1
180+25	R	W13-1	15 mph caution		4				
182+50	L	W1-2R	Right Curve Ahead				9	15	1
186+00	R	R2-1	35 mph		5			15	1
187+25	L	W1-8L	Chevron		5			15	1
187+25	L	W1-8R	Chevron		5			15	1
187+50	L	R1-1	36" Stop			7.46		15	1

Quitman County									
Location (Sta. #)	Lane Location	Sign Code	Sign Description	Type 3 Object Markers	0.08"	0.1"	0.125"	Square Tube Post (2#/LF)	Removal U-Channel
188+00	L	W1-8L	Chevron		5			15	1
188+00	L	W1-8R	Chevron		5			15	1
188+50	L	W1-8L	Chevron		5			15	1
190+25	R	??	School Bus Stop Ahead				9	15	1
191+00	L	W1-1L	Left Curve Ahead				9	15	1
191+00	L	W13-1	15 mph caution		4				
191+25	R	W1-3L	Curves Ahead				9	15	1
191+25	R	W13-1	15 mph caution		4				
194+00	L	R1-1	36" Stop				9	15	1
196+00	R	W1-8L	Chevron		5			15	1
196+50	R	W1-8L	Chevron		5			15	1
196+50	R	W1-8R	Chevron		5			15	1
196+75	R	W1-8L	Chevron		5			15	1
196+75	R	W1-8R	Chevron		5			15	1
197+00	R	W1-8L	Chevron		5			15	1
197+00	R	W1-8R	Chevron		5			15	1
201+25	L	W1-8L	Chevron		5			15	1
201+50	L	W1-8L	Chevron		5			15	1
202+00	R	R1-1	36" Stop			7.46		15	1
202+25	L	W1-8L	Chevron		5			15	1
205+00	L	??	School Bus Stop Ahead				9	15	1
206+25	L	W1-3L	Curves Ahead				9	15	1
206+25	L	W13-1	15 mph caution		4				
207+00	R	R1-1	36" Stop			7.46		15	1
208+50	R	R1-1	36" Stop			7.46		15	1
210+00	L	R2-1	35 mph		5			15	1
213+00	R	W2-2R	Side Road Rt.				9	15	1
213+75	L	W2-2L	Side Road Lt.				9	15	1
215+00	R	R2-1	55 mph		5			15	1
216+00	L	R2-1	45 mph		5			15	1
218+00	R	R1-1	36" Stop			7.46		15	1
222+50	L	W2-2L	Side Road Lt.				9	15	1
224+00	L	W3-5	45 mph speed zone ahead		5			15	1
299+00	R	W2-2L	Side Road Lt.				9	15	
304+00	L	R1-1	36" Stop			7.46		15	1
304+00	R	W1-7	Lt./Rt. Arrow			8		15	
307+00	R	M2-1	Jct.		2.19			15	1
307+00	R	M1-6	SR 6		4				
309+00	L	W2-2R	Side Road Rt.				9	15	
312+00	R	W3-1a	48" Stop Ahead				16		
314+25	L	M3-4	West		2				
314+25	L	M1-6	SR 316		5				
Total				4	158.19	130.06	286	1095	63

MISSISSIPPI DEPARTMENT OF TRANSPORTATION

SPECIAL PROVISION NO. 907-102-2

CODE: (IS)

DATE: 11/22/2017

SUBJECT: **Bidding Requirements and Conditions**

Section 102, Bidding Requirements and Conditions, of the 2017 Edition of the Mississippi Standard Specifications for Road and Bridge Construction is hereby amended as follows.

907-102.01--Prequalification of Bidders. Delete the last sentence of the third paragraph of Subsection 102.01 on page 13, and substitute the following.

The Bidder's Certificate of Responsibility number must be on file with the Department's Contract Administration Division prior to request for permission to bid.

907-102.02--Contents of Proposal Forms. Delete the fourth paragraph in Subsection 102.02 on page 13, and substitute the following.

Prospective bidders must complete an online request for permission to be eligible to bid a project. Upon approval, the bidder will be authorized to submit a bid electronically using Bid Express at <http://bidx.com>.

MISSISSIPPI DEPARTMENT OF TRANSPORTATION

SPECIAL PROVISION NO. 907-103-2

CODE: (SP)

DATE: 06/22/2017

SUBJECT: Award and Execution of Contract

Section 103, Award and Execution of Contract, of the 2017 Edition of the Mississippi Standard Specifications for Road and Bridge Construction is hereby amended as follows.

907-103.01--Consideration of Proposal. Delete the second and third paragraphs of Subsection 103.01 on page 19, and substitute the following.

907-103.01.1--For Projects Constructed Without Federal Funds. Resident Contractors actually domiciled in Mississippi are to be granted preference over nonresidents in awarding of Contracts financed 100% with State funds.

In consideration of proposals that are equal to or in excess of \$50,000 and financed 100% with State funds, a nonresident bidder domiciled in a state having laws granting preference to local Contractors will be considered for such contracts on the same basis as the nonresident bidder's state awards contracts to Mississippi Contractors bidding under similar circumstances. When a nonresident Contractor submits a bid equal to or in excess of \$50,000 on a contract financed 100% with State funds, a copy of the current laws from the state of domicile and an explanation thereof pertaining to treatment of nonresident Contractors shall be attached. If no preferential treatment is provided for Contractors in the state of domicile and contracts are awarded to the lowest responsible bidder, a statement to this effect shall be attached. Should the attachment not accompany the bid when submitted, the Contractor shall have 10 days following the opening of the bids to furnish the required information to the Contract Administration Director for attachment to the bid. Failure to provide the attachment within 10 days will result in the nonresident Contractor's bid being rejected and not considered for award. As used herein, the term "resident Contractor" includes a nonresident person, firm or corporation that has been qualified to do business in this State and has maintained a permanent full-time office in the State of Mississippi for two years prior to the submission of the bid, and the subsidiaries and affiliates of such a person, firm or corporation.

MISSISSIPPI DEPARTMENT OF TRANSPORTATION

SPECIAL PROVISION NO. 907-105-1

CODE: (SP)

DATE: 05/07/2021

SUBJECT: Authority of the Engineer

Section 105, Control of Work, of the 2017 Edition of the Mississippi Standard Specifications for Road and Bridge Construction is hereby amended as follows.

907-105.1--Authority of the Engineer. Delete the first sentence of the second paragraph of Subsection 105.01 on page 31, and substitute the following.

The Engineer has the right to suspend the work wholly or in part and to withhold payments because of the Contractor's failure to correct conditions unsafe for workmen or the general public, for failure to carry out provisions of the Contract, or for failure to carry out orders.

MISSISSIPPI DEPARTMENT OF TRANSPORTATION

SPECIAL PROVISION NO. 907-108-4

CODE: (SP)

DATE: 10/07/2020

SUBJECT: Subletting of Contract

Section 108, Prosecution and Progress, of the 2017 Edition of the Mississippi Standard Specifications for Road and Bridge Construction is hereby amended as follows.

907-108.01--Subletting of Contract.

907-108.01.1--General. Delete the third sentence of the tenth paragraph of Subsection 108.01.1 on the bottom of page 72.

MISSISSIPPI DEPARTMENT OF TRANSPORTATION

SPECIAL PROVISION NO. 907-109-4

CODE: (IS)

DATE: 04/19/2021

SUBJECT: Measurement and Payment

Section 109, Measurement and Payment, of the 2017 Edition of the Mississippi Standard Specifications for Road and Bridge Construction is hereby amended as follows.

907-109.01--Measurement of Quantities. Delete the sixth full paragraph of Subsection 109.01 on page 88, and substitute the following.

If appropriate based on the specific circumstances of the project, the Contractor may request that material specified to be measured by the cubic yard or ton be converted to the other measure. The Contractor must submit this request to the Engineer. The Engineer will provide an approval or denial in writing. The decision is in the sole discretion of the Engineer. If approved, factors for this conversion will be determined by the District Materials Engineer and agreed to by the Contractor. The conversion of the materials along with the conversion factor will be incorporated into the Contract by supplemental agreement. The supplemental agreement must be executed before such method of measurement is used.

907-109.04--Extra Work.

907-109.04.1--Supplemental Agreement. Delete the second paragraph of Subsection 109.04.1 on page 90.

907-109.06--Partial Payment.

907-109.06.2--Advancement on Materials.

Delete the next to last paragraph of Subsection 109.06.2 on page 95, and substitute the following.

Materials for which an advanced payment has been allowed must be paid for by the Contractor within 30 days of the estimate on which the advanced payment was first allowed and proof of said payment must be verified by the supplier. If proof of payment is not furnished within the allowable 30 days, the advanced payment will be deducted on subsequent current estimates until such time that proof of payment is furnished.

907-109.07--Changes in Material Costs. After the fifth paragraph of Subsection 109.07 on page 96, change the web address to the following.

https://mdot.ms.gov/portal/current_letting

MISSISSIPPI DEPARTMENT OF TRANSPORTATION

SPECIAL PROVISION NO. 907-410-4

CODE: (SP)

DATE: 04/13/2021

SUBJECT: Bituminous Surface Treatment

Section 410, Bituminous Surface Treatment, of the 2017 Edition of the Mississippi Standard Specifications for Road and Bridge Construction is hereby deleted in toto and replaced as follows.

SECTION 907-410 - BITUMINOUS SURFACE TREATMENT

907-410.01--Description. This work consists of the construction of a single layer bituminous surface treatment (chip seal) in accordance with these specifications and in reasonably close conformity with the lines shown on the plans or established by the Engineer. The application rates of asphalt material and aggregates will vary with aggregate size and existing roadway conditions but, for bid purposes only, the bituminous material and cover material shall be estimated by the Contractor. The rates in the below table are provided as guidance for the Contractor if desired with ranges in parentheses. The Engineer will review the actual application rates.

Seal Aggregate Gradation	Seal Aggregate Estimated Application Rate ¹ , ft ³ / yd ²	Bituminous Material	Bituminous Material Estimated Application Rate ¹ , gal/yd ¹
Size No. 7	0.30 (0.28-0.32)	AC	0.28 (0.23-0.33)
Size No. 8 or 89	0.25 (0.23-0.27)	AC	0.23 (0.18-0.28)
Size No. 7	0.30 (0.28-0.32)	Emulsified Asphalt	0.38 (0.33-0.43)
Size No. 8 or 89	0.25 (0.23-0.27)	Emulsified Asphalt	0.35 (0.30-0.40)

¹ Values shown are the best estimate followed by the range that could occur on the actual project.

907-410.02--Materials.

907-410.02.1--Bituminous Material. The type and grade of bituminous materials will be specified in the contract and shall conform to the applicable requirements of Section 702.

907-410.02.2--Cover Material. Cover material shall meet the applicable requirements of Subsection 703.14, but in any instance the cover material requirements listed below govern. The kind and type will be specified in the contract. The sampling location for cover material testing is project stockpile(s).

- The maximum allowable passing the #200 sieve will be 1.5% for any cover material used.
- For the Size No. 89 aggregate the range for passing the #8 sieve shall be 0-20%.

Only one type of aggregate or combination of aggregates shall be used on a particular project except with written permission of the Engineer.

Sites for stockpiles of materials shall be grubbed and cleaned prior to storing the aggregates, and the ground shall be firm, smooth, and well drained.

907-410.02.3--Mix Design. The Contractor shall submit to the Engineer for approval the application rates for the cover material and bituminous material using a design method such as that described by AASHTO PP 82. This design must be performed at a minimum of one time per construction season and can be required more frequently by the Engineer. This mix design provides the project a target, or design, application rate for bituminous material in gal/yd² and cover material in lbs/yd².

907-410.03--Construction Requirements.

907-410.03.1--General. Prime coats, when specified, shall meet the requirements of Section 408. After the application of a prime coat, the primed surface shall be kept in continuous repair. All holes, raveled areas, and areas deficient in prime shall be patched and repaired with approved materials.

Prior to any chip sealing operation, "Loose Rock" signs shall be installed and remain in place until all sealing operations are complete. Prior to any daily sealing operation, portable "Loose Rock" signs shall be installed in accordance with the drawing in the plans or contract documents. Portable signs shall be installed and remain in place on a daily basis in the active sealing area. Payment for signs shall be made under pay item no. 618-A: Maintenance of Traffic.

907-410.03.2--Seasonal and Weather Limitations. Emulsified asphalt and cut-back asphalt shall be applied only when both the air and pavement temperatures are above 70°F. Asphalt cement shall be applied only when both the air and surface temperatures are above 75°F.

Cut-back asphalt shall not be placed during the period between October 15 and March 1. No prime shall be placed when soil and weather conditions would prevent the proper placement and retention of the materials.

Bituminous materials for surface treatment shall not be placed during the period between November 1 and March 1, nor when weather conditions otherwise prevent the proper placement and retention of the materials.

On projects where completion of seal coats between November 1 and March 1 is determined to be in the public interest, the Engineer may permit variations from the above under the condition that all the following requirements are met:

- (a) The air and pavement temperature is 70°F or higher.
- (b) Asphalt cement used is cut back with naphtha of the type that will yield from 5-10 percent off at 680°F when tested by method AASHTO T 78 and the naphtha is added at the refinery.

- (c) As an alternate to (b), the Contractor substitutes a rapid setting cationic emulsified asphalt meeting the requirements of AASHTO M 208.
- (d) Aggregate is satisfactorily air dried in covered storage, or mechanically dried.
- (e) The sun is shining.
- (f) Aggregate is applied immediately behind the distributor.
- (g) No shot is made after mid-afternoon, and rolling is increased as directed for shots made after noon.
- (h) The Contractor retains full responsibility for the acceptable quality of the work within the intent of the contract, these conditions notwithstanding.
- (i) The work is performed under these modifications at no additional cost to the State.

Blanket authorization will not be given for use of the above modification but will be given only when completion of the surface treatment would make the facility available for use by public traffic, or for subsequent construction.

Prior to November 1 and after March 1, when the requirements of these specifications are being met, but conditions are less than good for the adhesion of cover aggregate to the bituminous material, the Engineer may permit or require, at no additional cost to the State that the asphalt cement be cut back with naphtha as previously indicated. Less than good placement conditions shall be understood to include, but not limited to: lower than desirable temperature; higher than desirable humidity; surface dampness; or coolness of the foundation or aggregate.

907-410.03.3--Equipment. All equipment used on the project shall be evaluated by the Engineer. The following or equivalent equipment shall be furnished.

907-410.03.3.1--Bituminous Heating Equipment. This equipment shall heat and maintain the bituminous material within specification requirements without damaging the material. The heating equipment shall be supplied with at least one accurate asphalt thermometer.

907-410.03.3.2--Asphalt Distributor. The asphalt distributor shall be self-propelled with a ground speed control device interconnected with the emulsified asphalt pump such that the specified application rate will be supplied at any speed. The asphalt distributor shall be capable of maintaining the emulsified asphalt at the specified temperature. The spray bar nozzles shall produce a uniform double or triple lap application fan spray, and the shutoff shall be instantaneous, with no dripping. All nozzles shall be oriented at the same angle between 15 and 30 degrees using the wrench supplied by the distributor manufacturer. Each asphalt distributor shall be capable of maintaining the specified application rate within ± 0.015 gal/yd² for each load.

907-410.03.3.3--Rotary Brooms. Rotary brooms shall be constructed to permit the revolutions of the broom to be adjusted to its progression and to permit adjustment of the broom in relation to the surface. The broom bristles shall be stiff enough to sweep clean without injury to the surface.

907-410.03.3.4--Pneumatic-Tire Rollers. Multiple self-propelled pneumatic-tire rollers capable of ballast loading, either with water or sand to allow the weight of the machine to be varied from 6 to 8 tons to achieve a minimum contact pressure of 80 lb/in.² shall be used. The alignment of the axles shall be such the rear axle tires, when inflated to the proper pressure, can

compact the voids untouched by the front-axle tire. All tires shall be as supplied by the roller manufacturer. Width of the rollers shall exceed 60 in.

Steel wheel rollers will not be allowed.

907-410.03.3.5--Trucks. Trucks of sufficient number and size to adequately supply the material shall be furnished.

907-410.03.3.6--Aggregate Spreaders. A self-propelled mechanical type aggregate spreader with a computerized spread control, capable of distributing the aggregate uniformly to the required width and at the designed rate shall be used.

907-410.03.3.7--Other Equipment. Drag brooms shall be furnished and used as conditions dictate.

907-410.03.3.8--Equipment Calibration. The Contractor shall provide proof of calibration of the asphalt distributor and the aggregate spreader. Calibration shall be conducted no earlier than five days prior to chip seal operations. The Contractor shall submit the results of the calibration procedure to the Engineer.

Uniformity of the aggregate applied transverse to the pavement centerline shall be in accordance with ASTM D5624. Tolerance for each pad tested for transverse spread rate shall be ± 10 percent of the average of the total transverse rate.

907-410.03.4--Preparation of Surface. The entire surface to be treated and at least one foot (1') on each side shall be cleaned by sweeping, blowing, or other methods until all dust, mud, clay lumps, and foreign material is removed. A primed base shall be properly cured and approved prior to application of bituminous material.

907-410.03.4.1--Cleaning Pavement. The roadway surface shall be cleaned by sweeping no more than 30 minutes prior to application of the emulsified asphalt and aggregate. However, this 30-minute window may be extended if authorized by the Engineer in cases where extending the time does not jeopardize a clean surface prior to chip seal operations. The pavement shall be swept with a motorized broom to remove loose material. Depressions not reached by the motorized broom with a hand broom shall be cleaned. The outer edges of the pavement to be sealed including an adjacent paved shoulder shall be cleaned.

907-410.03.4.2--Protecting Accessories. Utility castings (manholes, gate valve covers, catch basins, sensors, etc.) shall be covered to prevent coating with emulsified asphalt. Suitable covering includes plywood disks, Kraft paper, roofing felt or other approved methods. The protective coverings shall be removed before opening the road to traffic.

907-410.03.4.3--Stripe Removal. Prior to the chip seal operations, the Contractor shall remove all existing thermoplastic striping, thermoplastics legends, and raised pavement markers within the chip seal limits. Such removal shall be performed to the satisfaction of the Engineer.

907-410.03.5--Application of Bituminous Material. Bituminous material shall not be applied

until the prepared surface has been approved by the Engineer and any application rate adjustments must be approved by the Engineer. Where practicable, shots shall be at least 500 feet in length, and longer shots are desirable. No shot shall be in excess of a length which can be covered with aggregate before the bitumen hardens.

The bituminous material shall be uniformly heated and maintained within the specified temperature range during application. All material damaged by heating shall be rejected, and if a section has been treated with damaged material it shall be removed and replaced by the Contractor without additional compensation.

Emulsified asphalt material shall be applied with a pressure distributor at the specified rate, and at a temperature of 140° to 180°F. All other bituminous material shall be applied with a pressure distributor at the temperature range set out in Subsection 702.11. It shall be uniformly applied full width in one operation unless the Engineer permits it to be applied in narrower widths.

The application rate of the bituminous material shall result in complete and uniform coverage of the pavement receiving the bituminous surface treatment. If the application of the bituminous material does not result in complete coverage, the Contractor shall cease operations and adjust the distributor bar height and/or nozzle(s) such that complete coverage is attained. At a minimum, the application rate of the bituminous material should be verified daily by the Department.

The type and condition of the surface being covered and the size of the aggregate being used, will affect the required application rate of asphalt material. The Contractor shall begin with application rates as recommended by the mix design and accepted by the Engineer. Actual rates shall be established during the first application of bituminous material/aggregate and adjusted to field condition changes as required.

The application shall be stopped before the distributor is completely empty, and the length of shots shall be computed so that the application is stopped before it begins to run light. At the beginning of the application, including joints with preceding applications, intersections, and junctions with all pavements, etc., the distributor nozzles shall be operating at full force when the application begins. Building paper or other suitable material shall be used to receive the initial application from the nozzles before the asphalt reaches the road surface at the joint. The material shall be removed immediately after use without spilling asphalt on the road surface.

Spray bar nozzles shall be kept clean at all times, and should one become blocked during application of the bituminous material, the distributor shall be stopped immediately, and the nozzle cleaned before proceeding. Bare or light areas shall be immediately made uniform by use of a hand hose or pouring pot.

Due to possible spillage, the transfer of material from the delivery truck to the distributor shall be outside the limits of the roadway. Bituminous material shall not be discharged on the right-of-way when cleaning out the distributor. Any spillage shall be removed from the roadway and right-of-way.

During application of bituminous material, the Contractor shall provide adequate protection to

prevent marring or discoloration of pavements, structures, curbs, trees, etc., adjacent to the area being treated.

Longitudinal joints, when permitted, shall be reasonably true to line and parallel to the centerline. The overlap in the application of the bituminous material shall be the minimum to assure complete coverage.

At construction joints, the treatment of the edges shall be blended so that there are no gaps, the elevations are the same, and the joints are free from ridges and depressions.

907-410.03.6--Application of Cover Coat Material. The application of cover material shall immediately follow the application of bituminous material. Adhesion of the cover aggregate to the bitumen is the Contractor's responsibility. Application rate adjustments must be approved by the Engineer.

Aggregate shall be spread directly from approved spreaders. Trucks or spreaders shall not drive on the uncovered bituminous material.

Aggregate shall be placed at the design application rate. If necessary, the rate of application may be adjusted so that some emulsified asphalt can be seen between the aggregate chips, but not so much that aggregate chips adhere to the pneumatic rollers. If needed, additional adjustments may be made to the rate of application during the project, at the discretion of the Engineer.

During the first day of production and at least once a week thereafter, the application rate of the seal aggregate shall be verified by the Department to assure that the appropriate application rate of the seal aggregate is applied. The rate can be verified by placing a tarp of at least 1.0 yd² area on the roadway surface. After allowing the seal aggregate spreader to pass over the tarp, the aggregate on the tarp should be collected and weighed to determine the weight of aggregate. The measured weight should then be compared to the target weight calculated in Subsection 907-410.02.03.

Upon determining the target weight, it should be compared to the actual measured weight. If the difference in the target weight and the actual measured weight is over 2.5 pounds, the seal aggregate distributor should be adjusted such that the spread rate is within the above tolerance. The above procedure shall be repeated until the spread rate is within the allowable tolerance.

If at any point during production, excessive seal aggregate is noted, the seal aggregate application rate should be verified, and the spread rate adjusted. The intent is to minimize the amount of excess seal aggregate. Excess seal aggregate removed from the roadway surface after brooming shall be removed from the job site and should not be reused in the seal aggregate operation.

The dry aggregate shall be spread uniformly to cover the bituminous material with the quantity of aggregate specified by the Engineer. All deficient areas shall be covered by additional material.

If needed, approved drag brooms and hand brooms shall be used to distribute the aggregate

uniformly before and while the rolling operations are in progress.

The entire application of aggregate shall be rolled as soon as possible after application. Rolling shall be continued and repeated as often as necessary to key the cover material thoroughly into the bituminous material over the entire surface.

Pneumatic rollers shall be used in the sequence that will provide the rolling pattern that results in the best adhesion of the aggregate to the bituminous material and the best surface qualities.

Subsequent to the initial application of the aggregate the Contractor shall distribute, as many times as is deemed necessary, loose aggregate over the surface to absorb free bituminous material and to cover areas deficient in aggregate. Immediately following each distribution, the Contractor shall roll the entire surface treatment or seal with a pneumatic-tire roller until the maximum quantity of aggregate is embedded in the bitumen. Rolling in each case shall be at least one complete coverage and as many additional coverages as necessary to properly embed the aggregate. All rolling shall be performed while the temperature is favorable for sealing the aggregate into the bitumen.

In all cases there shall be at least five complete coverages of the entire surface of the treatment with a pneumatic-tire roller.

907-410.03.7--Control of Traffic. Unless otherwise advised, the Contractor's operations shall be schedule such that all lanes of traffic are open to the traveling public at the end of each day. Considering time needed for curing and preparation prior to opening traffic, the Contractor should not apply bituminous material two (2) hours before dusk, or longer, to allow sufficient time for bonding of the aggregates.

After the surface treatment has been rolled and the bituminous material has cured a minimum of one (1) hour, or longer if necessary to sufficiently hold the aggregate in place, the Contractor shall perform an initial brooming operation consisting of lightly sweeping excess aggregate material from the surface. After the initial brooming has been completed, public traffic will be allowed on the roadway.

Immediately the next morning, a final brooming shall be performed to remove any remaining excess aggregate material from the previous day's seal operation.

907-410.03.8--Quality Control. The Contractor shall be responsible for quality control (QC) sampling and testing and shall submit a written Quality Control Plan (QCP) acceptable to the Engineer.

907-410.03.8.1--Personnel. The Contractor shall be responsible for staffing their project with qualified personnel.

907-410.03.8.2--Testing Facilities and Equipment. The Contractor shall supply any testing and equipment needed to comply with their approved QCP.

907-410.03.8.3--Materials Testing. The Contractor shall test the materials utilized in a manner

to comply with their approved QCP and as required by the Engineer.

907-410.03.8.4--Compliance with Specifications. The Contractor shall attest in writing to the Department that the chip seal has been constructed in accordance with and meets the requirements of the specifications and their approved QCP at the conclusion of the project.

907-410.03.8.5--Department Acceptance. The Department will conduct acceptance sampling, testing, and inspection activities according to TMD-20-04-00-000 to ensure material quality, correct application rates, rolling, sweeping, and traffic control are within specification requirements.

907-410.04--Method of Measurement. Accepted bituminous asphalt for surface treatment will be measured by the gallon as prescribed in Subsection 109.01. Unless otherwise specified, distributor tank measurement will be used. The volume of material over five percent above the quantity ordered for each shot will be deducted from measured quantities, except that 15 percent will be allowed for irregular areas where hand spraying is necessary.

Aggregate cover material will be measured by the square yard. The area of all cover material and the volume of all bituminous material lost, wasted, damaged, or rejected, or applied outside of designated areas, or in excess of the Engineer's directions and tolerances allowed, or contrary to the specifications, will be deducted from measured quantities.

907-410.05--Basis of Payment. Bituminous asphalt for surface treatment will be paid for at the contract unit price per gallon. Aggregate cover material will be paid for at the contract unit price per square yard. The prices thus paid shall be full compensation for completing the work.

Payment will be made under:

907-410-A: Asphalt for Surface Treatment, Grade - per gallon

907-410-B: Seal Aggregate Cover Material, Size ____, Kind - per square yard

MISSISSIPPI DEPARTMENT OF TRANSPORTATION

SPECIAL PROVISION NO. 907-414-1

CODE: (SP)

DATE: 05/02/2017

SUBJECT: Polymer Modified Asphalt Rejuvenating Scrub Seal

Section 907-414, Scrub Seal, is hereby added to and made a part of the 2017 Edition of the Mississippi Standard Specifications for Road and Bridge Construction as follows.

SECTION 907-414 -- POLYMER MODIFIED ASPHALT REJUVENATING SCRUB SEAL

907-414.01--Description. This work shall consist of, but not be limited to, furnishing all labor, materials, equipment and transportation for the application of a polymer modified asphalt rejuvenating scrub seal. All ingredients shall be properly proportioned, mixed, and spread on the paved surface in accordance with this Specification and as directed by the Engineer.

907-414.02--Materials.

907-414.02.1--Aggregate. Unless otherwise noted, the aggregate material shall be one of the seal aggregate cover materials listed in and meeting the requirements of Subsection 703.14 of the Standard Specifications.

907-414.02.2--Asphalt Emulsion for Scrub Seal. The asphalt emulsion for scrub seal shall meet the requirements of the following table and shall be composed of a polymer modifier, a petroleum based rejuvenating agent, and asphalt.

Test on Emulsion	Method	Specification	
		(min)	(max)
Viscosity @77 (SFS)	AASHTO T 59	50	350
Residue, w% ⁽¹⁾	AASHTO T 59	60	-
Storage Stability, 24 h, %	AASHTO T 59	-	1.0
Sieve, w%	AASHTO T 59		0.1
Oil distillate, w%	AASHTO T 59		0.5
Test on Residue⁽¹⁾			
Viscosity @ 140°F, P	AASHTO T 202	-	3000
Penetration @ 4°C (39.2°F), 200 g, 60 sec	AASHTO T 59	30	-
Test on Polymer Modifier			
Swelling in rejuvenating agent, %; 48 hours exposure @ 104°F	ASTM D 471 ⁽²⁾ Modified	-	40% intact film
Test on Rejuvenating Agent			
Flash point, COC, °F	AASHTO T 48	380	-
Viscosity @ 140°F, CST	AASHTO T 201	50	175
Saturate, % by weight	ASTM D 2007	-	30
Asphaltenes	ASTM D 2007	-	1.0
Test on Residue			
Weight Change, %			6.5
Viscosity Ratio			3

- (1) Exception to AASHTO T59: Bring the temperature on the lower thermometer slowly to 350°F plus or minus 10°F. Maintain at this temperature for 20 minutes. Complete total distillation in 60 plus or minus 5 minutes from first application of heat.
- (2) Polymer Modifier Testing: Suitable substrate for film formation shall be polyethylene boards, silicone rubber sheeting, glass, or any substrate which produces a cured film of uniform cross-section. Polymer film shall be prepared from latex as follows:

Resistance to Swelling: Polymer films shall be formed by using a 50 mil drawdown bar and drawing down 50 mils of the latex on polyethylene boards. Films shall be cured for 14 days at 75°F and 50% humidity. Samples for resistance to swelling in rejuvenating agent shall be 1” by 2” rectangles cut from the cured film. Cut at least 3 specimens for each sample to be tested for swelling. Fill 3- 8 oz ointment tins with at least a ½” deep of rejuvenating agent. Swelling samples shall be weighed and then placed in the ointment tins on top of the rejuvenating agent. Then, add at least another ½” deep of rejuvenating agent over each of the latex samples. The ointment tins shall be covered and placed in an oven at 104°F for the specified 48 hours +/- 15 minutes. The ointment tins are allowed to cool to 75°F and then the latex films are removed from the tins. Unabsorbed rejuvenating agent is removed from the intact latex film by scraping with a rubber policeman and blotting with paper towels. If the latex film does not remain intact during removal from the tins or while removing the unabsorbed rejuvenating agent the sample shall be rejected. After the rejuvenating agent is removed from the samples they are then weighed. Percent swelling is reported as weight increase of the polymer film; report mass increase as a percent by weight of the original latex film mass upon exposure of films to the rejuvenating agent.

When a fog seal is required, the asphalt emulsion shall meet the requirements of Subsection 702.07.

907-414.02.2.1--Certification and Acceptance. The Emulsion supplier shall submit a certification that the polymer modified rejuvenating emulsion meets the requirements of the specification. The certification shall be submitted to the Engineer prior to starting the work. The Engineer will sample the polymer modified rejuvenating emulsion according to Department procedures. Final acceptance of the emulsion for scrub seal will be based on the Manufacturer's Certification and testing conducted by the Department.

907-414.03--Construction Requirements. The attached sign drawings shall be used during scrub seal operations. Prior to any sealing operation, the rectangular "Loose Rock" signs shall be installed and remain in place until all sealing operations are complete. Prior to any daily sealing operation, the portable "Loose Rock" signs shall be installed in accordance with the attached drawings. Portable signs shall be installed and remain in place on a daily basis in the active sealing area. Payment for signs shown on the sign detail drawings shall be made under pay item no. 618-A, Maintenance of Traffic.

907-414.03.1--Preparation. The work shall be done in the following order: Prepare the pavement surface; apply the asphalt emulsion for scrub seal and scrub the applied emulsion with a scrub broom as specified herein; apply the aggregate, roll the aggregate, broom the aggregate with a secondary broom when specified; and sweep up and dispose of excess aggregate. Excess aggregate shall be removed from the project unless otherwise approved by the Engineer.

Prior to the scrub seal operation, the Contractor shall remove any and all vegetation within the limits of the scrub seal installation. The use of herbicides will be allowed at the discretion of the Engineer.

If used, the herbicide shall be applied at least 10 days prior to the scrub seal operation, or as directed by the manufacturer of the approved herbicide. The application of the herbicide shall be performed in accordance with all applicable regulations. Any and all fines or clean-up costs for unlawful misuse or discarding of herbicides shall be the sole responsibility of the Contractor. Mixtures and spread rates for the herbicides shall be determined by the manufacturer's specifications. Wash down of equipment or discarding of herbicides shall not enter catch basins or positive drainage facilities.

Prior to the scrub seal operation, the Contractor shall remove all existing thermoplastic striping, thermoplastic legends and raised pavement markers within the scrub seal limits. Removal shall be performed to the satisfaction of the Engineer.

Prior to the scrub seal operation, all drain inlet covers, monument covers, and all other utility covers shall be protected from the Contractor's scrub seal operations by applying a sheet of plastic over the exposed facilities, or other methods approved by the Engineer. All traces of plastic, residual emulsion and aggregate shall be removed from covered objects after the application of the scrub seal and/or prior to final inspection of the project.

Immediately prior to the scrub sealing operations, the Contractor shall sweep the entire pavement surface.

907-414.03.2--Application. The scrub seal shall be applied from edge of pavement to edge of pavement. The edges of the scrub seal application shall be maintained in a neat and uniform line. Scrub seal shall not be applied on concrete gutters or pads unless directed by the Engineer.

The application of the asphalt emulsion for scrub seal shall be applied only when the ambient and pavement temperatures are above 70°F.

The asphalt emulsion for scrub seal shall be applied with a distributor truck at the following target rates. The actual emulsion application rate shall be determined from the surface demands and aggregate used. Any adjustments of the application rate shall be approved by the Engineer, and manufacturer’s representative if necessary.

The optimum application rate of bituminous material is dependent on the chosen seal aggregate gradation as well as the condition of the pavement in which the bituminous surface treatment is to be applied. The application rate of the bituminous material may be adjusted by the Engineer based on field conditions at the time of construction. Following are target application rates for bituminous material.

Seal Aggregate Gradation	Bituminous Material	Target Application Rate (gal/yd²)	Tolerance
Size No. 7	Emulsified Asphalt	0.33	+0.03
Size No. 8 or 89	Emulsified Asphalt	0.30	+0.03

Note: Emulsified Asphalt shall not be diluted. A sample of emulsified asphalt should be obtained from the Contractor’s distributor on the first day of production and thereafter at a frequency not to exceed 1 sample per 50,000 gallons. Because the time between sampling of the emulsified asphalt and the testing of the material can affect the test results, samples should be sent to the MDOT Central Lab for testing as soon as possible.

The asphalt emulsion for scrub seal temperature when applied shall be a minimum of 140° to 180°F. For smaller areas, the emulsion may be applied with a wand. The emulsion shall be immediately broomed to fill cracks and voids. The emulsion scrub broom shall be as described below.

Immediately following the application of the emulsion to the road surface, the material shall be scrubbed with a scrub broom for the purpose of forcing the emulsion into the existing surface and distributing the emulsion evenly over variable road surface contours.

The application of the asphalt emulsion for scrub seal and scrub broom operation shall cease 40 feet prior to the end of the application. The remaining asphalt emulsion for scrub seal shall be dragged out by the scrub broom, and the remaining emulsified material required to complete the pass shall be applied only by the distributor truck, at the specified rate.

Immediately following the scrubbing of emulsion, aggregate shall be applied at the following application rates.

Size 7 Slag, Stone, Gravel or Expanded Clay	= 0.30 ±0.02 ft ³ / yd ²
Size 8 Expanded Clay	= 0.25 ±0.02 ft ³ / yd ²
Size 89 Slag, Stone, or Gravel	= 0.25 ±0.02 ft ³ / yd ²

The actual aggregate application rate shall be as required by the surface demands and the emulsion used. The rate shall be adjusted, within the specified limit, up or down so that no “bleed through” occurs during rolling.

During the first day of production and at least once a week thereafter, the application rate of the aggregate shall be verified by the Department to assure that the appropriate application rate of the aggregate is applied. The rate can be verified by placing a tarp of at least 1.0 yd² area on the roadway surface. After allowing the aggregate spreader to pass over the tarp, the aggregate on the tarp should be collected and weighed to determine the weight of aggregate. The measured weight should then be compared to the target weight calculated using the following formula.

$$W = 0.85(G_{sb})(U_w)(R)(A)(e)$$

Where:

- W = target weight of aggregate in lbs.
- G_{sb} = bulk specific gravity of aggregate
- U_w = Unit weight of water at 70°F = 62.3 lbs./ft³
- R = target application rate in ft³/yd²
- A = area of tarp in yd²
- e = air voids in loose aggregate = 0.4

- G_{sb} for gravel = 2.650
- G_{sb} for limestone = 2.700

Note: Bulk specific gravities of expanded clay and steel slag should be obtained from the seal aggregate supplier.

Upon determining the target weight, it should be compared to the actual measured weight. If the difference in the target weight and the actual measured weight is over 2.5 pounds, the aggregate distributor should be adjusted such that the spread rate is within the above tolerance. The above procedure shall be repeated until the spread rate is within the allowable tolerance.

If at any point during production, excessive aggregate is noted, the aggregate application rate should be verified and the spread rate adjusted. The intent is to minimize the amount of excess aggregate. Excess aggregate removed from the roadway surface after brooming shall be removed from the job site and should not be reused in the aggregate operation.

The dry aggregate shall be spread uniformly to cover the bituminous material with the quantity of mineral aggregate specified by the Engineer. All deficient areas shall be covered by additional material. All excess cover material shall be removed from the surface and stockpiled or used as directed.

A minimum of two self-propelled pneumatic-tired rollers shall be used for the required rolling of the aggregate. The pneumatic-tired rollers shall be in good working condition and actively rolling at all times during the scrub seal operation. The pneumatic-tired rollers shall be minimum 5-ton rollers. The pneumatic-tired rollers shall be operated in such a manner to prevent the dislodging of newly applied aggregate.

If specified, a fog seal will be placed at a rate of 0.11 gallons per square yard, or as directed by the Project Engineer. The fog seal shall not be placed until after final brooming.

907-414.03.3--Stockpile Sites. Sites for stockpiles of materials shall be grubbed and cleaned prior to storing the aggregates, and the ground shall be firm, smooth, and well drained.

907-414.03.4--Equipment. The following equipment shall be used for the scrub-seal operations.

- A. **Asphalt Distributor.** The asphalt distributor for application of the emulsion shall have a full circulation spray bar that is adjustable to at least sixteen feet (16') wide in two (2) feet increments and capable of heating and circulating the emulsion simultaneously. It must have computerized rate control for adjusting and controlling the application from the cab within 0.01 gallons per square yard increments. The distributor shall also be equipped with a volume measuring device and a thermometer for measuring the emulsion temperature in the tank.
- B. **Scrub Broom.** A scrub broom as described herein shall be used to scrub the emulsion after application. The scrub broom frame shall be constructed of metal. The scrub broom shall be attached to and pulled by the distributor truck. The scrub broom must be equipped with a means of raising and lowering the scrub broom at desired points. It shall be towable in the elevated position to the next area of construction. The weight of the broom assembly shall be such that it does not squeegee the emulsion off the roadway surface.

The main body of the scrub broom shall have a frame size as shown in the drawing at the end of this special provision. The nearest and furthest members, paralleling the back of the distributor truck, and diagonal members shall be equipped with street brooms. The leading member and the trailing member shall have broom heads angled at 10 to 15 degrees off the centerline of the supporting member. The diagonal members shall have broom heads attached in line with the centerline of the supporting member. Each individual street broom attached to the scrub broom assembly shall be 3.5 inches wide x 6.5 inches high x 16 inches long and have stiff nylon bristles. Bristle height is to be maintained at a minimum of five inches (5"). The scrub broom shall be equipped with hinged wing assemblies attached to the main body not to exceed 4.5 feet per side, with diagonals and equipped with street brooms. The purpose of the maximum rigid frame width and the hinged wing extensions is not only for maximum width of 16 feet but to maintain the scrubbing process evenly as contours and cross-sections change across the existing road surface.

- C. **Aggregate Spreader.** A self-propelled aggregate spreader with front discharge that can evenly distribute aggregate.

- D. Roller. A minimum of two (2) pneumatic rollers weighing at least five (5) tons each.
- E. Power Broom. Two (2) mechanically powered kick-brooms or vacuum type brooms.

907-414.03.5--Opening to Traffic. Unless otherwise advised, the Contractor’s operations shall be schedule such that all lanes of traffic are open to the traveling public at the end of each day. Considering time needed for curing and preparation prior to opening traffic, the Contractor should not apply bituminous material two (2) hours before dusk, or longer, to allow sufficient time for bonding of the aggregates.

After the scrub seal has been rolled and the bituminous material has cured a minimum of one (1) hour, or longer if necessary to sufficiently hold the aggregate in place, the Contractor shall perform an initial brooming operation consisting of lightly sweeping excess aggregate material from the surface. After the initial brooming has been completed, public traffic will be allowed on the roadway.

Immediately the next morning, a final brooming shall be performed to remove any remaining excess aggregate material from the previous day’s seal operation.

907-414.04--Method of Measurement. Scrub seal shall be measured by the square yard.

Accepted quantities for asphalt for fog seal will be measured by the gallon as prescribed in Subsection 109.01. Unless otherwise specified, distributor tank measurement will be used. The volume of material over five percent (5%) above the quantity ordered for each shot will be deducted from measured quantities, except that 15 percent will be allowed for irregular areas where hand spraying is necessary.

907-414.05--Basis of Payment. Scrub seal, measured as prescribed above, will be paid for at the contract bid price per square yard, which shall be full compensation for furnishing all labor, materials, equipment, temporary markers, vegetation removal, cleaning of the surface, pre-sweeping, post-sweeping, doing all the work involved in mixing, applying and protecting the polymer modified asphaltic rejuvenating scrub seal, and all incidentals necessary to complete the work.

Asphalt for fog seal will be paid for at the contract unit price per gallon, which shall be full compensation for furnishing all labor, materials, equipment, applying and protecting the fog seal, and all incidentals necessary to complete the work.

Payment will be made under:

907-414-A: Scrub Seal - per square yard

907-414-B: Asphalt for Fog Seal - per gallon

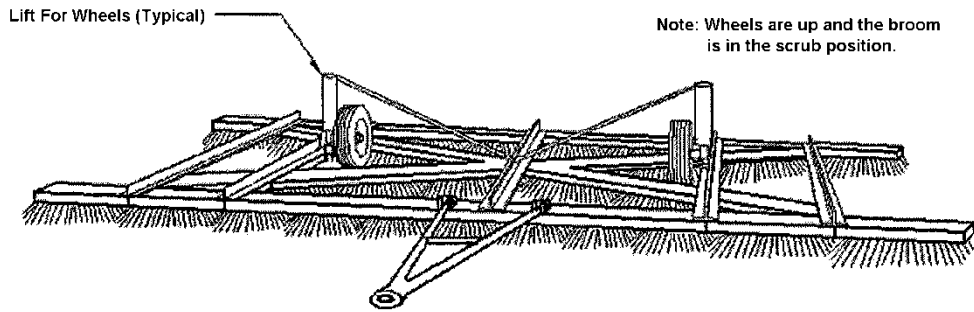
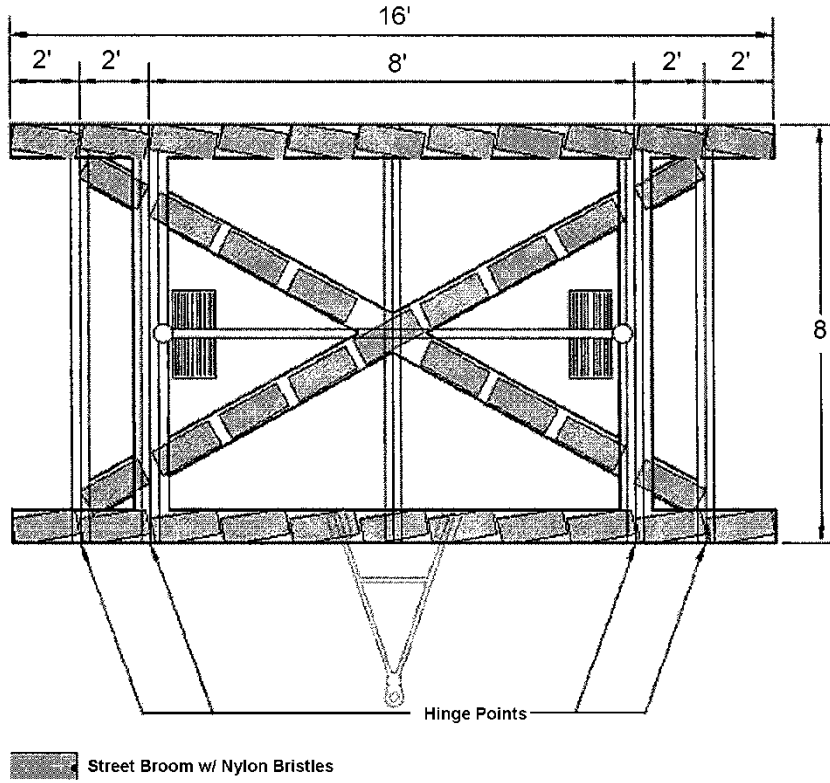

Scrub Broom

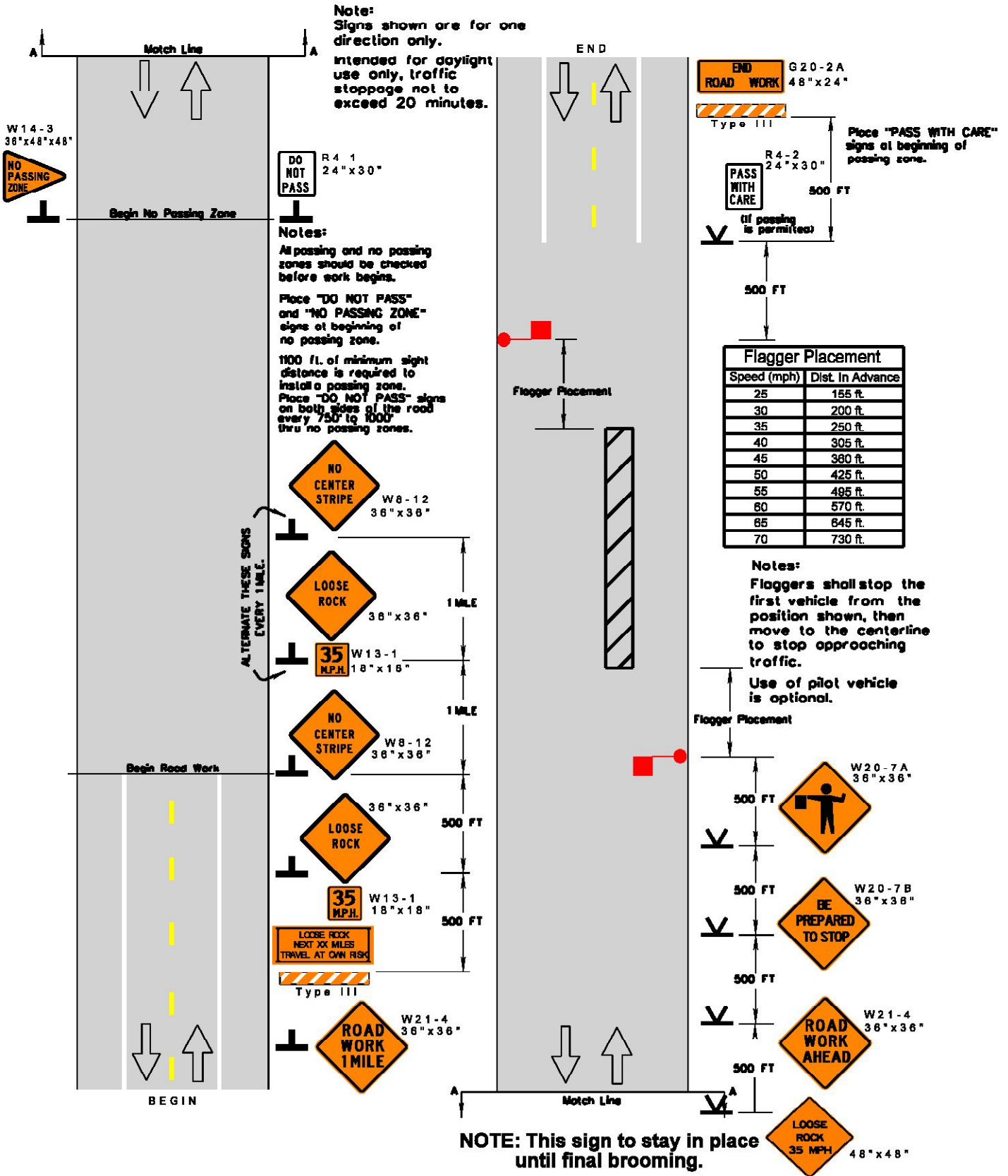

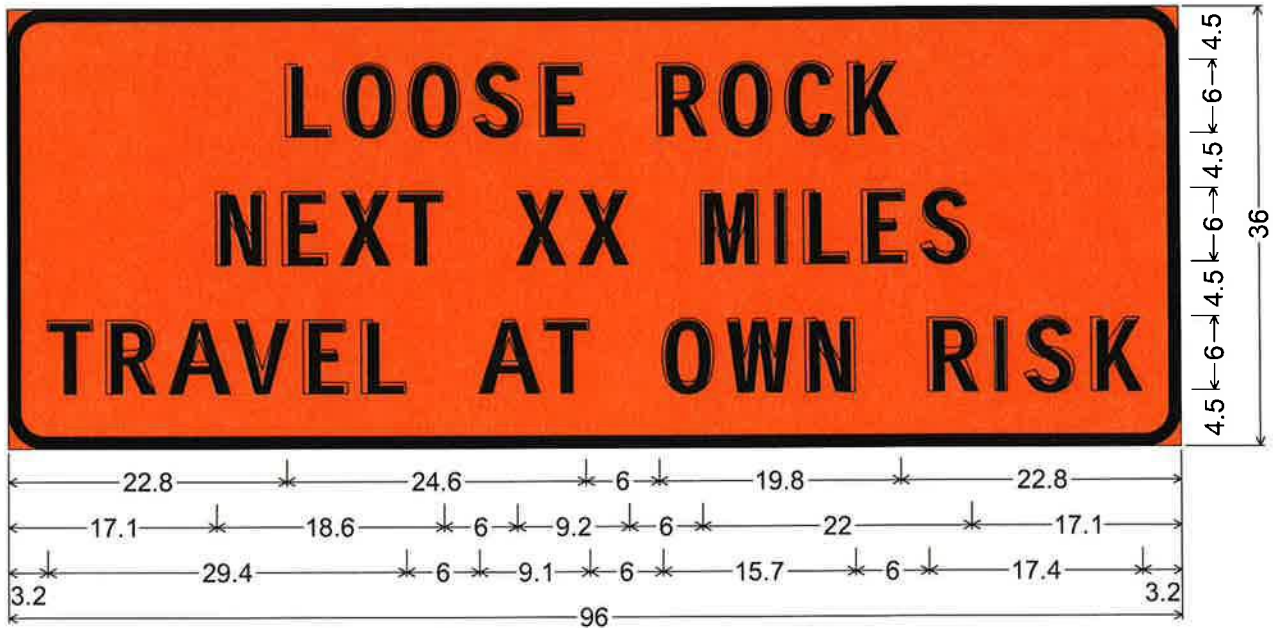

3.0" Radius, 1.0" Border, Black on Orange;
 "LOOSE ROCK" D; "NEXT XX MILES" D; "TRAVEL AT OWN RISK" D;
 Table of letter and object lefts.

L	O	O	S	E	R	O	C	K						
22.8	27.6	33.0	38.3	43.7	53.4	58.5	63.9	69.0						
N	E	X	T	X	X	M	I	L	E	S				
17.1	22.5	27.3	32.1	41.7	46.9	56.9	63.0	65.3	70.1	74.9				
T	R	A	V	E	L	A	T	O	W	N	R	I	S	K
3.2	8.0	13.2	18.6	24.2	29.0	38.6	44.0	53.7	59.0	65.4	75.4	80.9	83.2	88.6

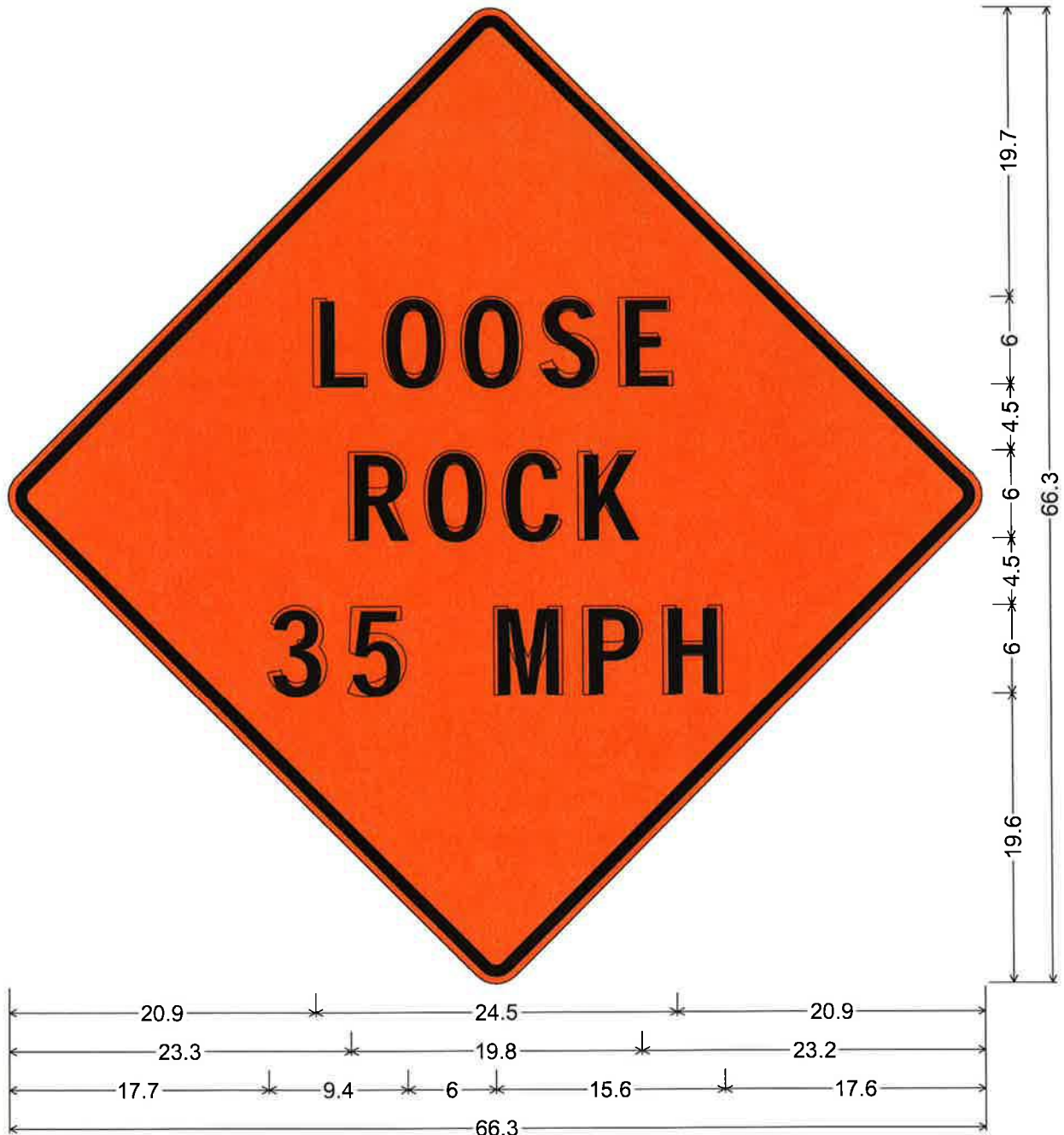

48.0" across sides 1.9" Radius, 0.8" Border, 0.5" Indent, Black on Orange;

"LOOSE" D; "ROCK" D; "35 MPH" D;

Table of letter and object lefts.

L	O	O	S	E
20.9	25.7	31.0	36.4	41.8
R	O	C	K	
23.3	28.4	33.8	38.9	
3	5	M	P	H
17.7	23.1	33.1	39.2	44.6

MISSISSIPPI DEPARTMENT OF TRANSPORTATION

SPECIAL PROVISION NO. 907-424-1

CODE: (SP)

DATE: 01/17/2017

SUBJECT: Roadbed Reclamation with Cement

Section 907-424, Roadbed Reclamation with Cement, is hereby added to and made a part of the 2017 Edition of the Mississippi Standard Specifications for Road and Bridge Construction as follows.

SECTION 907-424 – ROADBED RECLAMATION WITH CEMENT

907-424.01--Description. This work consists of pulverizing and mixing an existing pavement together with base, and/or subgrade materials with cement and water to produce a uniform base course for a pavement.

907-424.02--Materials. The materials to be treated shall consist of materials in place or placed under this contract.

The materials, when sampled and tested in accordance with Subsection 700.03, shall meet the requirements of the following Subsections:

Cement	701.01 and 701.02
Water	714.01.1 and 714.01.2
Curing Material	702.07

907-424.02.1--Combined Aggregate Blend. The existing pavement shall be pulverized to meet the below gradation prior to the addition of water or cement.

Sieve Size	Percent Passing by Weight
2.0 inch	98-100
1.5 inch	Minimum 95

If needed, virgin aggregate and/or recycled asphalt pavement can be blended with the reclaimed roadbed material to meet the above gradation. Virgin aggregate shall meet the applicable requirements of Subsection 703.06 of the Standard Specifications.

907-424.03--Construction Requirements. When vertical longitudinal joints are required, the joints shall be constructed parallel to the centerline by cutting into the existing edge for a sufficient distance to provide a vertical face for the depth of the course. The material cut away may be disposed of by spreading in a thin layer on the adjacent lane to be constructed, or otherwise disposed of in a manner satisfactory to the Engineer. If dry, cut joints shall be moistened immediately in advance of placing fresh mixture adjacent to them.

907-424.03.1--Weather Limitations. The Contractor shall mix the pulverized materials, cement, and water only when the weather permits the course to be finished without interruption in the time specified.

Roadbed Reclamation shall not be performed when the temperature is below 45°F nor when the Engineer determines, based on the latest information available from the National Weather Service, that the forecast temperature will fall below 45°F within the next five (5) days in the area in which the project is located. No cement shall be placed on a frozen foundation or mixed with frozen material.

907-424.03.2--Equipment. The pulverizing and mixing shall be done with one or more machines that produce the required degree of pulverization and uniformity in accordance with the gradation requirements of Subsection 907-424.02.1.

Other pieces of equipment that may be required are a motorized grader, cement spreading unit, water truck meeting the requirements of Subsection 308.03.2.

Rollers shall be of sufficient number, type, size, and weight to accomplish the required compaction.

The Engineer will not approve specific equipment for this work prior to its use on the project but will require the Contractor to use equipment that will produce a base course mixture meeting the requirements of these specifications.

Nuclear moisture-density gauges shall meet the requirements of Subsection 401.02.7.1.

907-424.03.3--Test Section. The first five hundred (500) linear feet of roadbed reclamation will serve as a test section. The Engineer and the Contractor will evaluate results of the test section in relation to contract requirements. This evaluation may include, but is not limited to, gradations of untreated pulverized materials, moisture contents of untreated materials or compacted treated courses, or densities of compacted treated courses.

If the Engineer determines the work is not satisfactory, the Contractor shall revise procedures and augment or replace equipment as necessary to assure work completion in accordance with the contract, shall repeat the test section after the procedural or equipment modifications are complete, and shall correct all deficient work at no additional cost to the Department. The test section requirements shall be repeated until the Engineer determines the work is satisfactory.

907-424.03.4--Joining a Previous Day's Work. Prior to joining a previous day's work, or work more than two hours old, a vertical construction joint, normal to the center-line of the roadway, shall be made in the old work by cutting into the existing edge for a sufficient distance to provide a vertical face of at least two inches (2"). The material cut away may be disposed of by spreading in a thin layer on an adjacent area to be treated. The joint shall be moistened if dry. Additional processing shall not be started until the construction joint has been approved by the Engineer.

907-424.03.5--Length of Roadbed Allowed to Be Processed. Except by written permission of the Engineer, the length of existing pavement pulverized at any time shall not exceed the length that can be completely pulverized, mixed, compacted, and covered by the curing seal in the same working day.

907-424.03.6--Pulverizing and Mixing. The width and depth of the required pulverizing and mixing will be shown on Plans. The depth of pulverization shall be controlled to ensure depth of pulverization is within $\pm 1/2$ inch of the plan thickness. Pulverizing and mixing may require one or more passes. Upon completion, the in-place materials shall meet the uniformity requirements of these specifications.

The pulverizing and mixing shall breakup the existing roadbed and meet the gradation requirements of Subsection 907-424.02.1. The moisture content after final mixing shall be at or near the optimum moisture content of the mixture such that the required minimum density is achieved.

907-424.03.7--Moisture Content Prior to Spreading of Cement. The moisture content of the pulverized material shall be checked prior to the spreading of cement. In addition, the moisture content shall be checked by the Contractor as often as required to ensure the moisture-density of each subplot meets the requirements of Subsection 907-424.03.9. The Contractor shall adjust the procedures and/or equipment for adding water as necessary to control the moisture content of the treated course.

907-424.03.8--Spreading of Cement. Spreading of cement shall meet the requirements of Subsection 308.03.7 and following the requirements for the Road Mix Method described in Subsection 308.03.7.3. Pneumatic application through a slotted pipe will not be permitted.

907-424.03.9--Mixing. Mixing shall meet the requirement of Subsection 308.03.8. Mixing shall be accomplished by either Multiple Pass Mixing in Subsection 308.03.8.2.1 or Single Pass Mixing in Subsection 308.03.8.2.2. For mixing units that inject moisture into the mixing chamber, a gauge or gauges shall be provided to allow the continuous monitoring of the amount of water that is applied. When the width of the mixer is such that the entire width of the mixed material can not be accomplished in a single pass, the successive increments shall be of such length that the full width of cement-stabilized base material may be promptly mixed, compacted and finished, with not more than 30 minutes between mixing adjacent passes. Prior to compaction, the mixture of the water, cement, and pulverized materials shall be within $\pm 1\%$ of mixture design optimum moisture content and shall be in a condition suitable for immediate compaction without further mixing or grading.

907-424.03.10--Compaction and Finishing. The pulverizing, mixing, and compaction shall be a continuous operation. The compaction of the mixture of water, cement, and pulverized materials shall begin within 30 minutes after the final mixing. Compaction and finishing shall be completed within a period of one hour after the final mixing. Upon completion of the one hour compaction and finishing period, rollers or other heavy construction equipment should not be allowed on the completed section until the curing period is complete.

After the mixture has been compacted, the surface shall be shaped to the required lines, grades, and cross sections to within the required tolerances. During the shaping, light scarifying may be necessary to prevent the formation of compaction planes. Broom dragging or clipping of the surface may be required as a part of the process of shaping the surface during compaction. The surface material shall be maintained at the specified moisture content during finishing operations. The final compaction and finishing operations may be varied, if necessary, to produce a smooth, dense surface free of surface compaction planes, cracks, ridges or loose material.

907-424.03.11--Density. Acceptance of finished reclaimed material for required density will be performed on a lot to lot basis. Each lot will be 2,500 feet per layer processed. When the plans require the reclamation of multiple lanes and the lanes are not processed in one continuous operation, each lane will be considered a separate lot for testing and acceptance purposes. At the discretion of the Engineer, a residual portion of a lot completed during a day's operation may be considered a separate lot or may be included in the previous or subsequent lot, except that any day's operation of less than one full lot will be considered a lot.

The lot will be divided into five approximately equal sublots with one density test taken at random in each subplot. The average of the five density tests shall equal or exceed 97.0 percent with no single subplot density test below 95.0 percent. Sublots with a density below 95.0 percent shall be corrected at no additional cost to the State and retested for acceptance.

Each lot of work found not to meet the density requirement of 97.0 percent of maximum density, may remain in place with a reduction in payment as set out in the following table:

PAYMENT SCHEDULE FOR COMPACTION

<u>Pay Factor</u>	<u>Lot Density **</u> <u>% of Maximum Density</u>
1.00	97.0 and above
0.90	96.0 – 96.9
0.50	95.0 – 95.9

** Any lot with a density less than 95% of maximum density shall be corrected at no additional cost to the state.

907-424.03.12--Thickness Requirements. The thickness of the base will be checked by the Engineer at intervals not to exceed 500 feet or more often if necessary. The thickness of the reconstructed layer shall not vary more than $\pm 1/2$ inch from that shown on the plans. High spots in the finished surface may be corrected by motor grader or planer provided the resulting thickness is within the tolerances listed above.

Measurements will be made promptly upon completion of compaction and finishing in order that correction may be made before the mixture has hardened.

907-424.03.13--Finished Grade. The Contractor shall be responsible for grade controls. The cross slope shall not vary by more than 0.50% from the required slope shown on the plans. The cross slope may be corrected providing the resulting thickness is within the allowable tolerance. The Contractor shall provide a straight edge and template to check the surface as directed by the Engineer.

907-424.03.14--Surface Moisture. The finished surface shall be kept moist until the curing seal is applied.

907-424.03.15--Protection and Curing. A curing seal of Emulsified Asphalt, Grade EA-1, AE-P, SS-1, CMS-2h, or MS-2h shall be applied following final compaction of the reclaimed layer. The emulsion shall be applied at a rate of 0.20 gallon per square yard using a pressurized distributor spray bar.

907-424.03.16--Blotter Material. Blotter material shall be concrete sand, or a material approved by the Engineer. Blotter material shall be placed on the curing seal prior to opening the reclamation area to traffic.

907-424.04--Method of Measurement. Roadbed Reclamation with Cement will be measured per square yard. The length will be measured along the surface of the treated course. The width shall be the width specified on the plans.

Cement incorporated into the accepted work will be measured per ton in accordance with the provisions of Section 109.

No separate payment will be made for curing seal. Costs for curing seal shall be included in other items bid.

907-424.05--Basis of Payment. Roadbed Reclamation with Cement will be paid for at the contract unit price per square yard. Cement will be paid for at the contract unit price per ton. The prices thus paid shall be full compensation for furnishing all materials (cement, water, blotter material, curing seal, etc.), equipment, tools, labor, and incidentals necessary to complete the work.

Payment will be made under:

907-424-A: Roadbed Reclamation with Cement * - per square yard

907-424-B: Cement - per ton

* Other information may be added

MISSISSIPPI DEPARTMENT OF TRANSPORTATION

SUPPLEMENT TO SPECIAL PROVISION NO. 907-618-4

DATE: 05/22/2023

PROJECT: SP-0835-00(006) / 109224301 & SP-0835-00(007) / 109224302
Coahoma & Quitman Counties

After the first paragraph of Subsection 907-618.01.2 on page 1, add the following.

Additional traffic control devices will be required as follows.

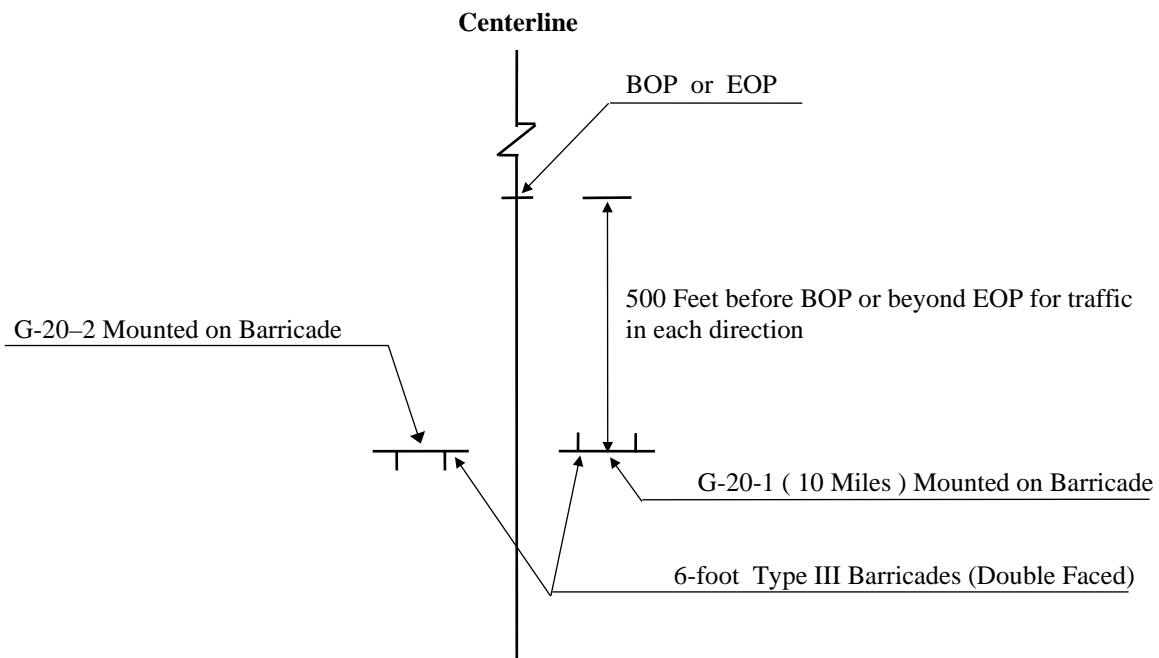

ADDITIONAL TRAFFIC CONTROL SIGNS REQUIRED:

- 16 - W20-1 "AHEAD" signs required. One (1) W20-1 "AHEAD" sign is required at each local road or street entering the project.
- 97 - R4-1 "DO NOT PASS" signs required.
- 17 - R4-2 "PASS WITH CARE" signs required.
- 17 - W14-3 "NO PASSING ZONE" signs required.

R4-1 "DO NOT PASS", R4-2 "PASS WITH CARE", and W14-3 "NO PASSING ZONE" signs are required in accordance with Subsection 618.03.3, this drawing, and as specified in the Manual on Uniform Traffic Control Devices.

All construction signs and barricades shown on this page shall be included in the bid price for Pay Item 618-A, Maintenance of Traffic. Fluorescent orange sheeting shall be used on all construction and traffic control signs except for R4-1 and R4-2 signs which shall be black legend and border on white background.

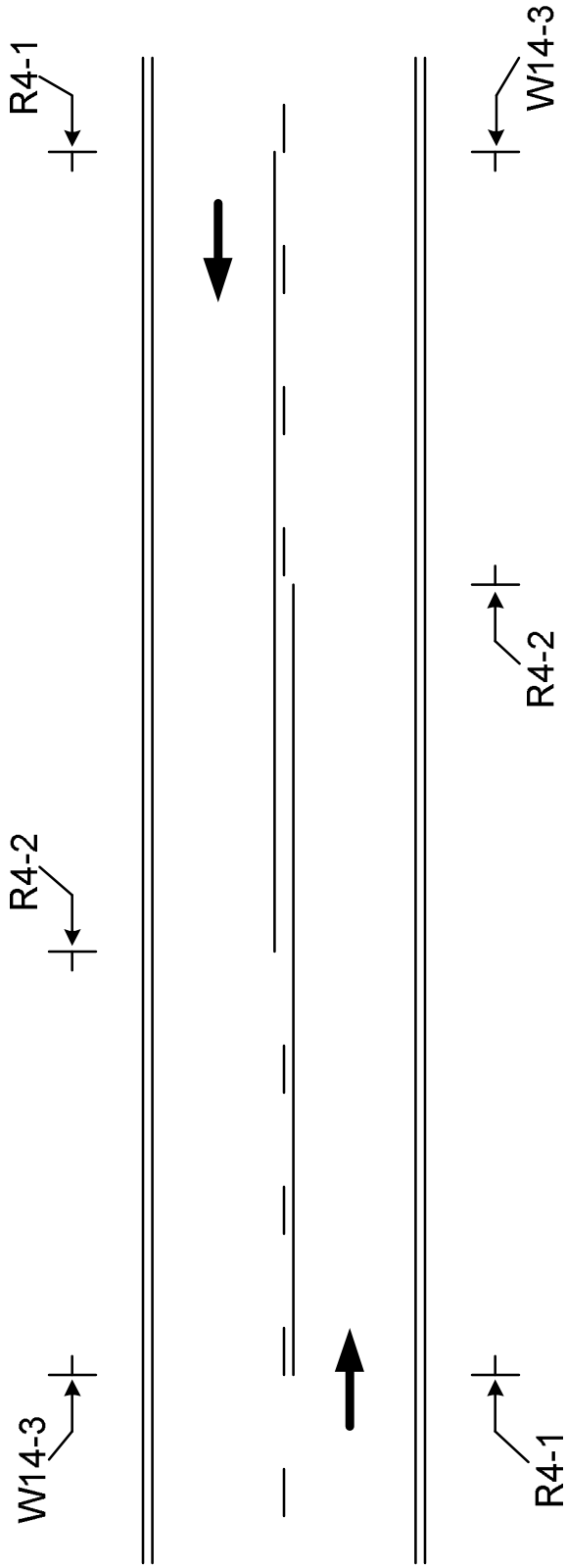

The W14-3, No Passing Zone sign, shall be placed on the left side of the road at the beginning of each no passing zone.

The R4-1, Do Not Pass signs, shall be placed on the right side of the road at the beginning of the no passing zone. Additional R4-1 signs shall be placed right and left in increments of 750 to 1000 feet throughout the length of the no passing zone.

The R4-2, Pass With Care sign, shall be placed on the right side of the road at the end of the no passing zone.

The R4-1, R4-2 and W14-3 signs are to be used when standard pavement markings are not in place. The signs may also be used to emphasize pavement markings.

MISSISSIPPI DEPARTMENT OF TRANSPORTATION

SPECIAL PROVISION NO. 907-618-4

CODE: (SP)

DATE: 02/01/2018

SUBJECT: Additional Signing Requirements

Section 618, Maintenance of Traffic and Traffic Control Plan, of the 2017 Edition of the Mississippi Standard Specifications for Road and Bridge Construction is hereby amended as follows.

907-618.01.2--Traffic Control Plan. At the end of Subsection 618.01.2 on page 441, add the following:

For compliance with the traffic control plan, the Contractor will be required to install and maintain **traffic control devices** at various locations throughout the project. Payment for these **devices** will be included in the price bid for pay item no. 618-A, Maintenance of Traffic per lump sum.

MISSISSIPPI DEPARTMENT OF TRANSPORTATION

SPECIAL PROVISION NO. 907-619-5

CODE: (IS)

DATE: 01/17/2018

SUBJECT: Traffic Control for Construction Zones

Section 619, Traffic Control for Construction Zones, of the 2017 Edition of the Mississippi Standard Specifications for Road and Bridge Construction is hereby amended as follows.

907-619.02--Materials.

907-619.02.8--Traffic Signals and Flashers. Delete Subsection 619.02.8.1 on pages 452 thru 455, and substitute the following.

907-619.02.8.1-Portable Traffic Signals. Portable traffic signals shall be trailer or pedestal mounted units that provide for easy, legal transportation and quick setup and deployment. Each unit shall be self-contained. The types of portable traffic signals are as follows.

- Type 1 portable traffic signal shall include two signal heads per trailer with one signal head mounted on an overhead mast arm that can be extended over the travel lane, and the other signal head shall be mounted on the vertical upright of the trailer.
- Type 2 portable traffic signal shall include one signal head that is mounted on the vertical upright of the pedestal/cart or trailer. Pedestal/Cart mounted shall be designated as Type 2A and Trailer mounted shall be designated as Type 2B. Type 2 portable traffic signals shall be tested to MASH Standards or NCHRP Test Level 3 crash testing requirements by an accredited independent test facility, with supporting documentation available upon request.
- Type 3 portable traffic signal shall be the same as Type 1 mentioned above but with enhanced capabilities as mentioned in each applicable section below.

The portable traffic signals shall be MUTCD Compliant and utilize standard ITE signal heads, and adhere to the ITE Specifications and Standards for Vehicle Traffic Control Signal Heads, Light Emitting Diode (LED) Circular Signal Supplement. The units shall be battery powered with a solar charging system, and be equipped with an onboard battery charger capable of being used with a 120V AC power source. Portable traffic signals shall be able to communicate with other portable signals via 900 MHz or other accepted wireless communications. If wireless connectivity is not feasible, hardwired connectivity shall be an acceptable alternative, as approved by the Engineer. Portable Traffic Signals shall include all the major components listed below or be able to perform the functions of these components. The major components of the unit shall include, but are not limited to, the trailer or pedestal/cart, telescoping mast arm (on Type 1 and 3), signal head(s) and back plates, traffic signal controller with operating software, solar charging system with batteries, input and output devices, vehicle detection, flasher units, conflict monitor, relays,

communications system and other equipment required for the safe operation and installation of the unit.

907-619.02.8.1.1--Signal Heads. The signal heads and all applicable components of the portable traffic signal shall meet the physical display and operational requirements of conventional traffic signals as specific in the Manual on Uniform Traffic Control Devices (MUTCD). The signal heads shall be cast aluminum or polycarbonate and shall meet the requirements laid out in the Mississippi Standard Specification for traffic signal heads and associated MDOT material specifications for traffic signal heads. The signal heads shall accommodate standard 12-inch LED indications meeting the ITE Specification “Vehicle Traffic Control Signal Heads” and ITE Specifications and Standards for Vehicle Traffic Control Signal Heads, Light Emitting Diode (LED) Circular Signal Supplement.

For Type 1, Type 2 and Type 3 portable traffic signals, the signal heads shall have the ability to be rotated 180 degrees to face in the opposite direction and shall have the ability to rotate and lock in approximately 10 degree increments to position the signal head for the optimum visibility to motorists.

For Type 1 portable traffic signals, each unit shall contain two signal heads with one signal head mounted on an overhead mast arm that can be extended over the travel lane with a minimum clearance of 17 feet measured from the bottom of the signal head unit to the road surface. The lower signal head shall be mounted to the vertical upright of the trailer at a minimum height of eight feet (8') from the bottom of the signal head unit to the road surface.

For Type 2 portable traffic signals, the signal head shall be mounted to the vertical upright of the trailer at a minimum height of eight feet (8') from the bottom of the signal head unit to the road surface.

For Type 3 portable traffic signals, each unit shall be the same as Type 1 mentioned above but with enhanced capabilities as mentioned below.

907-619.02.8.1.2--Controller and Operating Requirements. The portable traffic signal (Types 1, 2, and 3) shall include a solid state Controller Unit (CU) that is in compliance with NEMA TS 5 Performance Standard. The CU shall have an easy to read front panel backlit display for viewing and programming the configuration settings and CU status. The CU shall be capable of operating the portable traffic signal system in a fixed time, traffic actuated or manual control mode. Multiple portable traffic signals shall have the capability to be interconnected to form a portable traffic signal system. Each portable traffic signal within a connected system shall have the capability to serve as either the master or remote signal. Each portable traffic signal shall include a Conflict Monitor Unit (CMU), or Malfunction Management Unit (MMU) to ensure phase conflicts do not exist during operation.

For Type 1 and Type 2 portable traffic signals, a minimum of five (5) automatic time-of-day timing plans within a 24-hour period should be available in fixed time mode. The CU should have the ability to control a minimum of four (4) traffic phases with programmable cycle time adjustments and user adjustable red, amber, minimum green and maximum green times. The CU shall have

the capability of programming green and red times from 1 to 999 seconds and yellow times up to 15 seconds in one-second increments. The CU shall also have the capability of facilitating standby modes of red, red flash and yellow flash.

For Type 3 portable traffic signals, a minimum of ten (10) automatic time-of-day timing plans within a 24-hour period should be available in fixed time mode. The CU should have the ability to control a minimum of 16 traffic phases with programmable cycle time adjustments and user adjustable red, amber, minimum green and maximum green times. The CU shall have the capability of programming green and red times from 1 to 999 seconds and yellow times up to 15 seconds in one-second increments. The CU shall also have the capability of facilitating standby modes of red, red flash and yellow flash.

The system shall also have the ability to operate in vehicle actuation mode when vehicle detection components are used. The operating system shall have the capability to allow the Portable Traffic Signal to be connected to and controlled by a standard NEMA controller.

The system shall have the capability to be controlled remotely using a hardwired or wireless remote. The wireless radio remote shall be capable of communicating at a clear line of site distance up to ¼ mile from the master.

The CU shall have the capability of interfacing with a Remote Monitoring System (RMS) capable of reporting signal location, battery voltage, and system faults. The RMS shall include a password-protected web site, viewable via an internet connection. In the event of a system fault, the RMS shall provide specific information concerning the cause of the system fault (example: "red lamp on signal number 1 out"). The RMS shall immediately contact previously designated individuals via SMS text messaging or email, upon a fault event.

The active timing program operating the PTS system shall be available and viewable through the RMS website at all times. The RMS shall maintain a history of the operating system in each signal including total operating hours, alerts, and the location of the PTS trailer.

907-619.02.8.1.3--Wireless Communications. The portable traffic signals shall communicate with other portable traffic signals within the signal system via license-free wireless 900 MHZ radio link communications as specified in Subsection 662.02.2 of the radio Interconnect System specification. The radio units shall maintain communications at a minimum distance of one (1) mile. The radio system shall conform to the applicable Federal Communications Commission requirements and all applicable state and local requirements.

The portable traffic signals shall be in direct communication at all times either by wireless or hardware connection to provide for the required conflict monitoring / malfunction management system.

907-619.02.8.1.4--Power Requirements. Each Portable Traffic Signal shall be equipped with a power source consisting of a solar collection array, solar controller and/or charging unit and batteries sufficient to operate the signal system. The number and size of batteries shall be sufficient to operate the Type 1 and Type 3 signals for a minimum of 30 days and Type 2A signals for

minimum of five (5) days, and Type 2B signals for minimum of 15 days without additional charging or assist from the solar array. An on-board battery charger shall be compatible with both the solar array and with a 120V AC power source.

For Type 1 signals, the solar panel array shall provide for a minimum of 440 watts of solar collection capability.

For Type 2A signals, the solar panel array shall provide for a minimum of 90 watts of solar collection capability.

For Type 2B signals, the solar panel array shall provide for a minimum of 110 watts of solar collection capability.

For Type 3 signals, the solar panel array shall provide for a minimum of 480 watts of solar collection capability and shall include a tilt and rotate system to optimally position the panels.

All instrumentation for the electrical system and battery compartment shall be contained in a lockable weatherproof enclosure. Solar panels shall be secured to the mounting brackets for theft prevention.

907-619.02.8.1.5--Trailer and Lift System. The trailer or pedestal/cart and all mounted components shall conform to the wind loading requirements as follows: 100 mph minimum for Type 1 portable traffic signals, 55 mph minimum for Type 2A portable traffic signals, 75 mph minimum for Type 2B portable traffic signals, and 90 mph minimum for Type 3 portable traffic signals as described in the AASHTO *Standard Specifications for Highway Signs, Luminaries and Traffic Signals*, as specified in the plans including all interims and updates. At the request of the Engineer, proof of conformance to these wind load ratings shall be verified by a third-party. No additional loose ballast shall be used to meet these wind load requirements. The trailer shall be made of structural steel and shall include four (4) leveling/stabilizer jacks capable of lifting the trailer a minimum of six inches (6”).

The trailer or pedestal shall be equipped with a mechanical, hydraulic or electric lift system sufficient for one person to be able to raise and lower the vertical upright and/or horizontal mast arm to and from the operating position.

For Type 1, 2B, and Type 3 signals, the trailer shall be equipped to provide legal and safe transport on the public highway system at speeds up to 55 mph.

All exterior metal surfaces, except signal heads and back plates, shall be powder-coat painted highway safety orange.

907-619.02.9--Impact Attenuators. Delete the sentence in the first paragraph of Subsection 619.02.9 on page 455, and substitute the following.

Impact attenuators must be listed on the Department's APL.

907-619.02.11--Snap-Back Delineators. Delete the sentence in the paragraph of Subsection 619.02.11 on page 456, and substitute the following.

Snap-back delineators shall be selected from the list of surface mounted flexible delineator posts as shown on the Department's APL.

907-619.02.14--Changeable Message Sign.

907-619.02.14.5--PCMS Controller and Storage Cabinets. Delete the fifth sentence in the first paragraph of Subsection 619.02.14.5 on pages 462 and 463, and substitute the following.

The controller cabinet shall be illuminated.

907-619.05--Basis of Payment. Add the following to the list of pay items ending on page 480.

907-619-E3: Changeable Message Sign ***** - per each

907-619-H2: Traffic Signal, Portable, Type ____ - per each

MISSISSIPPI DEPARTMENT OF TRANSPORTATION

SPECIAL PROVISION NO. 907-701-3

CODE: (IS)

DATE: 05/04/2021

SUBJECT: Hydraulic Cement

Section 701, Hydraulic Cement, of the 2017 Edition of the Mississippi Standard Specifications for Road and Bridge Construction is hereby amended as follows.

907-701.01--General. In the first sentence of the second paragraph of Subsection 701.01 on page 718, change “mills” to “plants.”

In the second sentence of the sixth paragraph of Subsection 701.01 on pages 718 and 719, change “shall” to “will.”

907-701.02--Portland Cement.

907-701.02.1-General.

907-701.02.1.2--Alkali Content. Delete the sentence in Subsection 701.02.1.2 on page 719, and substitute the following.

When used in portland cement concrete, the total alkali contribution from all cement types in this Subsection shall not exceed 4.0 lb. per cubic yard of concrete calculated as follows:

$$\text{lb alkali per cu Yd} = \frac{(\text{lb cement per cu Yd}) \times (\% \text{Na}_2\text{O equivalent in cement})}{100}$$

In the above calculation, the maximum cement alkali content reported on the cement mill certificate shall be used. An example calculation can be found in the Department’s *Concrete Field Manual*.

907-701.02.2--Replacement by Other Cementitious Materials. Delete the paragraph in Subsection 701.02.2 on page 719, and substitute the following.

The maximum replacement of cement by weight is 25% for fly ash or 50% for ground granulated blast furnace slag (GGBFS). Replacement contents below 20% for fly ash or 45% for GGBFS may be used, but will not be given any special considerations, such as the maximum acceptance temperature for portland cement concrete containing pozzolans in Subsection 804.02.13.1.5. Special considerations shall only apply for replacement of cement by fly ash or GGBFS.

Delete Subsection 701.02.2.1 on pages 719 and 720, and substitute the following.

907-701.02.2.1--Portland Cement Concrete Exposed to Soluble Sulfate Conditions or Seawater.

When portland cement concrete is exposed to moderate or severe soluble sulfate conditions, or to seawater, cement types and replacement of cement by Class F fly ash or GGBFS shall be as follows in Table 1. Class C fly ash shall not be used as a replacement for cement in any of the sulfate exposure conditions listed in Table 1.

Table 1- Cementitious Materials for Soluble Sulfate Conditions or Seawater

Sulfate Exposure	Water-soluble sulfate (SO ₄) in soil, % by mass	Sulfate (SO ₄) in water, ppm	Cementitious material required
Moderate and Seawater	0.10 - 0.20	150 - 1,500	Type I cement with one of the following replacements of cement by weight: 24.5 - 25.0% Class F fly ash, or 49.5 - 50.0% GGBFS or Type II ^{**} cement
Severe	0.20 - 2.00	1,500 - 10,000	Type I cement with a replacement by weight of 49.5 - 50.0% GGBFS, or Type II [*] cement with one of the following replacements of cement by weight: 24.5 - 25.0% Class F fly ash, or 49.5 - 50.0% GGBFS

* Type III cement conforming to AASHTO M85 with a maximum 8% tricalcium aluminate (C₃A) may be used in lieu of Type II cement as allowed in Subsection 701.02.1; this cement is given the designation “Type III(MS).”

** Class F fly ash or GGBFS may be added as a replacement for cement as allowed in Subsection 907-701.02.2.

Delete Subsection 701.02.2.2 on page 720, and substitute the following.

907-701.02.2.2--Portland Cement for Soil Stabilization Exposed to Soluble Sulfate Conditions or Seawater. When portland cement for use in soil stabilization is exposed to moderate or severe soluble sulfate conditions, or to seawater, cement types and replacement of cement by Class F fly ash or GGBFS shall meet the requirements of Subsection 701.02.2.1.

907-701.04--Blended Hydraulic Cement.

907-701.04.1--General. Delete Subsection 701.04.1.1 on page 720, and substitute the following.

907-701.04.1.1--Types of Blended Hydraulic Cement. Blended hydraulic cements (blended cements) shall be of the following types and conform to AASHTO M 240:

- Type IL – Portland-limestone cement
- Type IP – Portland-pozzolan cement
- Type IS – Portland blast-furnace slag cement

Blended cement Types IL, IP, and IS meeting the “MS” sulfate resistance requirement listed in AASHTO M 240, Table 3 shall have the “(MS)” suffix added to the type designation.

907-701.04.1.2--Alkali Content. Delete the sentence in Subsection 701.04.1.2 on page 720, and substitute the following.

All blended cement types shall be made with clinker that would result in cement meeting the requirements of Subsection 701.02.1.2 when used in the production of AASHTO M 85, Type I or Type II cement.

The blended cement manufacturer shall include the percent equivalent alkalis as Na₂O on their cement mill reports.

When calculating the total alkali contribution with blended cements, use the equivalent alkali content of the base portland cement. An example calculation for cases where blended cements are used can be found in the Department’s *Concrete Field Manual*.

907-701.04.2--Replacement by Other Cementitious Materials. Delete the paragraph in Subsection 701.04.2 on page 720, and substitute the following.

The maximum replacement of blended cement Type IL by weight is 35% for fly ash or 50% for GGBFS. Replacement contents below 20% for fly ash or 45% for GGBFS may be used, but will not be given any special considerations, such as the maximum acceptance temperature for blended cement concrete containing pozzolans in Subsection 804.02.13.1.5. Special considerations shall only apply for replacement of blended cement by fly ash or GGBFS.

No additional cementitious materials, such as portland cement, blended cement, fly ash, GGBFS, or others, shall be added to or as a replacement for blended cement Types IP and IS.

Delete Subsection 701.04.2.1 on pages 720 and 721, and substitute the following.

907-701.04.2.1--Blended Cement Concrete Exposed to Soluble Sulfate Conditions or Seawater. When blended cement concrete is exposed to moderate or severe soluble sulfate conditions, or to seawater, cement types and replacement of cement by Class F fly ash or GGBFS shall be as follows in Table 2. Class C fly ash shall not be used as a replacement for cement in any of the sulfate exposure conditions listed in Table 2.

Table 2- Cementitious Materials for Soluble Sulfate Conditions or Seawater

Sulfate Exposure	Water-soluble sulfate (SO ₄) in soil, % by mass	Sulfate (SO ₄) in water, ppm	Cementitious material required
Moderate and Seawater	0.10 - 0.20	150 - 1,500	Type IL (MS) * cement, Type IL cement with one of the following replacements of cement by weight: 24.5 - 35.0% Class F fly ash, or 49.5 - 50.0% GGBFS, Type IP (MS) cement, or Type IS (MS) cement
Severe	0.20 - 2.00	1,500 - 10,000	Type IL cement with a replacement of cement by weight of 49.5 - 50.0% GGBFS, or Type IL (MS) cement with one of following replacements of cement by weight: 24.5 - 35.0% Class F fly ash, or 49.5 - 50.0% GGBFS

* Class F fly ash or GGBFS may be added as a replacement for cement as allowed in Subsection 907-701.04.2.

Delete Subsection 701.04.2.2 on page 721, and substitute the following.

907-701.04.2.2--Blended Cement for Soil Stabilization Exposed to Soluble Sulfate Conditions or Seawater. When blended cement for use in soil stabilization is exposed to moderate or severe soluble sulfate conditions, or to seawater, cement types and replacement of cement by Class F fly ash or GGBFS shall meet the requirements of Subsection 701.04.2.1.

Delete Subsection 701.04.3 on page 721.

MISSISSIPPI DEPARTMENT OF TRANSPORTATION

SPECIAL PROVISION NO. 907-702-4

CODE: (IS)

DATE: 09/11/2018

SUBJECT: Bituminous Materials

Section 702, Bituminous Materials, of the 2017 Edition of the Mississippi Standard Specifications for Road and Bridge Construction is hereby amended as follows.

907-702.04--Sampling. Delete the sentence in Subsection 702.04 on page 722, and substitute the following.

Sampling of bituminous materials shall be as set out in AASHTO R 66.

907-702.07--Emulsified Asphalt. Delete the last sentence in Subsection 702.07 on page 724, and substitute the following.

Asphalt for fog seal shall conform to the requirements of Subsection 907-702.12, Table V.

907-702.12--Tables. Delete Table V in Subsection 702.12 on page 729, and substitute the following.

**TABLE V
SPECIFICATION FOR FOG SEAL**

Test Requirements	LD-7		CHPF-1		Test Method
	Min.	Max.	Min.	Max.	
Viscosity, Saybolt Furol, @ 25°C, Sec.	10	100	-	100	AASHTO T 72
Storage Stability Test, 24 hr, %	-	1	-	1	AASHTO T 59
Settlement, 5 day, %	-	5	-	-	AASHTO T 59
Oil Distillate, %	-	1	-	-	AASHTO T 59
Sieve Test, % *	-	0.3	-	0.1	AASHTO T 59
Residue by Distillation, %	40	-	40	-	AASHTO T 59
Test on Residue from Distillation					
Penetration @ 25°C, 100g, 5 sec	-	20	40	90	AASHTO T 49
Softening Point, °C	65	-	-	-	ASTM D 36
Solubility in trichloroethylene, %	97.5	-	-	-	AASHTO T 44
Elastic Recovery @ 25°C, %	-	-	40	-	AASHTO T 301
Original DSR @ 82° (G*/Sinδ, 10 rad/sec)	1	-	-	-	AASHTO T 111

* The Sieve Test result is tested for reporting purposes only and may be waived if no application problems are present in the field.

MISSISSIPPI DEPARTMENT OF TRANSPORTATION

SPECIAL PROVISION NO. 907-703-2

CODE: (SP)

DATE: 11/29/2022

SUBJECT: Gradation

Section 703, Aggregates, of the 2017 Edition of the Mississippi Standard Specifications for Road and Bridge Construction is hereby amended as follows.

907-703.03--Coarse Aggregates for Hydraulic Cement Concrete.

907-703.03.2--Detail Requirements.

907-703.03.2.4--Gradation. In the table in Subsection 703.03.2.4 on page 734, add 100 for the percent passing by weight on the 1½-inch sieve for Size No. 67 aggregates.

Delete Note 2 under the table in Subsection 703.03.2.4 on page 734, and substitute the following.

Note ² – 100 percent shall pass the 1-inch sieve for Size 67 used in Class F and Class FX concrete.

MISSISSIPPI DEPARTMENT OF TRANSPORTATION

SPECIAL PROVISION NO. 907-705-1

CODE: (IS)

DATE: 06/13/2018

SUBJECT: Stone Riprap

Section 705, Stone Blanket Protection and Filter Blanket Materials, of the 2017 Edition of the Mississippi Standard Specifications for Road and Bridge Construction is hereby amended as follows.

907-705.04--Stone Riprap. Delete the last sentence of the first paragraph of Subsection 705.04 on page 750, and substitute the following.

Quality requirements for rock to be furnished under these specifications will come from a pre-approved source and be visually approved prior to use.

MISSISSIPPI DEPARTMENT OF TRANSPORTATION

SPECIAL PROVISION NO. 907-707-3

CODE: (IS)

DATE: 10/27/2021

SUBJECT: Joint Materials

Section 707, Joint Materials, of the 2017 Edition of the Mississippi Standard Specifications for Road and Bridge Construction is hereby amended as follows.

907-707.02--Joint Filler.

907-707.02.2--Preformed Sponge, Rubber, Cork and Closed-Cell Polypropylene Foam Joint Fillers for concrete Paving and Structural Constructions. Delete the two paragraphs of Subsection 707.02.2 on page 755, and substitute the following.

Preformed joint filler shall conform to AASHTO M 153 for sponge, rubber, and cork and tested according to ASTM D545. The type required will be indicated on the plans.

Closed-cell polypropylene foam shall conform to the requirements in ASTM D8139 and tested in accordance with ASTM D545.

907-707.02.3--Wood. Delete paragraph (b) of Subsection 707.02.3 on page 755, and substitute the following:

- (b) Dimensions shall be as shown on the plans. Dimensions shown on the plans are “dressed” sizes in accordance with Table 3 of the American Softwood Lumber Standard, SP-20. At the discretion of the Engineer, a 3/4-inch dressed board may be used in lieu of a 1-inch dressed board. A tolerance of plus or minus 1/16 inch thickness and plus or minus 1/8 inch width will be permitted. For slip-form paving a tolerance of minus 1/4 inch on each end in length will be permitted.

907-707.06--Flexible Plastic Gasket for Joining Conduit. Delete the third paragraph of Subsection 707.06 on page 756, and substitute the following.

The Department may require the performance test described in ASTM C 990.

MISSISSIPPI DEPARTMENT OF TRANSPORTATION

SPECIAL PROVISION NO. 907-711-2

CODE: (IS)

DATE: 09/11/2018

SUBJECT: Plain Steel Wire

Section 711, Reinforcement and Wire Rope, of the 2017 Edition of the Mississippi Standard Specifications for Road and Bridge Construction is hereby amended as follows.

907-711.02--Deformed and Plain Carbon-Steel Bars for Concrete Reinforcing.

907-711.02.3--Steel Welded and Non-Welded Wire Reinforcement, Plain and Deformed, for Concrete.

907-711.02.3.1--Plain Steel Wire. Delete the sentence in Subsection 711.02.3.1 on pages 780 and 781, and substitute the following.

Plain steel wire and plain steel welded wire shall conform to the requirements of AASHTO M 336.

MISSISSIPPI DEPARTMENT OF TRANSPORTATION

SPECIAL PROVISION NO. 907-712-1

CODE: (SP)

DATE: 12/07/2021

SUBJECT: Fence and Guardrail

Section 712, Fence and Guardrail, of the 2017 Edition of the Mississippi Standard Specifications for Road and Bridge Construction is hereby amended as follows.

907-712.01--General. After the sentence in Subsection 712.01 on page 785, add the following.

All materials' inspection, testing, and certification will be performed in accordance with the requirements of the current version of the Department's *Materials Division Inspection, Testing, and Certification Manual*.

Delete Subsections 712.02 and 712.03 on page 785, and substitute the following.

907-712.02--Barbed Wire. Barbed wire shall conform to the requirements of AASHTO M 280. In the coastal counties of Hancock, Harrison, and Jackson, either Coating Type Z Class 3 or Coating Type A shall be furnished. In all other areas of the State, either Coating Type Z Class 1, Coating Type Z Class 3, Coating Type ZA Class 60, or Coating Type A shall be furnished.

907-712.03--Metallic-Coated, Steel Woven Wire Fence Fabric. Woven wire fencing (i.e., "hog wire") shall conform to the requirements of AASHTO M 279. In the coastal counties of Hancock, Harrison, and Jackson, either Coating Type Z Class 3 or Coating Type A shall be furnished. In all other areas of the State, either Coating Type Z Class 1, Coating Type Z Class 3, Coating Type ZA Class 60, or Coating Type A shall be furnished.

907-712.04--Chain Link Fence. Delete Subsections 712.04.1 thru 712.04.7 on pages 785 & 786, and substitute the following.

907-712.04.1--Fabric. In the coastal counties of Hancock, Harrison, and Jackson, either Type I Class D, Type II, Type III, or Type IV fabrics shall be furnished. In all other areas of the State, either Type I Class C, Type I Class D, Type II, Type III, or Type IV fabrics shall be furnished.

907-712.04.2--Tie Wire. Tie wire shall be of the same material as the fencing wire being used, shall be of good commercial quality, and shall meet the requirements of AASHTO M 181. Either Type I, Type II, Type III, or Type IV tie wire shall be furnished.

907-712.04.3--Tension Wire. Tension wire shall be of the same material as the fencing wire being used, shall be of good commercial quality, and shall meet the requirements of AASHTO M 181. In the coastal counties of Hancock, Harrison, and Jackson, either Type I Class 3, Type II, Type III, or Type IV tension shall be furnished. In all other areas of the State, either Type II, Type III, Type IV, or Type I Classes 1, 2, or 3 tension wires shall be furnished.

907-712.04.4--Posts Rails, Gate Frames, and Expansion Sleeves. Posts, rails, gate frames, and expansion sleeves shall conform to the requirements for posts in Subsection 712.05.2, unless otherwise designated in the contract.

907-712.04.5--Miscellaneous Fittings and Hardware. Miscellaneous fittings and hardware shall conform to the requirements of Subsection 712.16.

907-712.05--Fence Posts and Braces.

907-712.05.1--Treated Timber Posts and Braces.

907-712.05.1.1--General. Delete the third, fourth, fifth, and sixth paragraphs of Subsection 712.05.1.1 on page 787, and substitute the following.

All wood posts and braces shall be treated in accordance with Subsections 718.03 and 718.04.

907-712.05.1.2--Round Posts. Delete the last sentence of the last paragraph of Subsection 712.05.1.2 on page 788.

907-712.05.1.3--Sawed Posts. Delete the last sentence of the paragraph of Subsection 712.05.1.3 on page 788.

907-712.05.1.4--Sawed Braces. Delete the last sentence of the paragraph of Subsection 712.05.1.4 on page 788.

Delete Subsection 712.05.2 on page 788, and substitute the following.

907-712.05.2--Metal Posts.

907-712.05.2.1--Round Steel Pipe. Round steel pipe shall meet the requirements of AASHTO M 181, either Grade 1 (i.e., meeting the requirements in ASTM F 1083) or Grade 2 (i.e., meeting the requirements of ASTM F 1043).

Round steel pipe shall be sized in accordance with NPS (nominal pipe size) designations as shown on Plans, and not according to the outer or inner pipe diameter.

907-712.05.2.2--Steel Fence Post and Assemblies, Hot-Wrought. Steel posts with the following section shapes, Tee, channel or U, and Y-Bar shall meet the requirements of AASHTO M 281, galvanized in accordance with the requirements of AASHTO M 111, unless otherwise specified in the contract. Acceptance of these steel posts shall be by certification from the manufacturer, producer, supplier, or fabricator, as applicable.

907-712.05.2.3--Blank.

907-712.05.2.4--Steel H-Beam Posts. Steel H-Beam posts shall be produced from structural quality weldable steel having a minimum yield strength of 45,000 psi and shall be galvanized in accordance with ASTM A 123. Steel H-Beam line posts shall be 2.250 inches by 1.625 inches and shall weigh 3.43 pounds per foot. A tolerance of plus or minus 5.0 percent is allowed for

weight per foot. A tolerance of plus or minus 1.0 percent is allowed for dimensions.

907-712.05.2.5--Aluminum-Alloy Posts and Assemblies. Round aluminum-alloy posts shall meet the requirements of ASTM B 241, Alloy 6061, T6. Aluminum-Alloy H-Beam posts shall meet the requirements of ASTM B 221, Alloy 6061, T6.

907-712.05.2.6--Formed Steel Section Posts. Formed steel section posts, "C" sections, shall be formed from sheet steel conforming to ASTM A 1011, Grade 45, and shall be galvanized in accordance with ASTM A 123.

907-712.06--Guard and Guardrail Posts.

907-712.06.2--Treated Wood Posts.

907-712.06.2.1--Square Posts. Delete the paragraph in Subsection 712.06.2.1 on page 789, and substitute the following.

All square posts shall be inspected for conformance with Section 712.05, except that the posts may be rough and shall be within $\pm 3/8$ " of the dimensions shown on the plans.

907-712.06.2.2--Round Posts. Delete the paragraph in Subsection 712.06.2.2 on page 789, and substitute the following.

All round posts shall be inspected for conformance with Section 712.05, except that the posts shall be of the shape and dimensions shown on the plans.

907-712.06.5--Treated Wood Blocks for Use with Metal Guardrail Posts. Delete the paragraphs of Subsection 712.06.5 on pages 789 & 790, and substitute the following.

Treated wood blocks for use with metal guardrail posts shall be within $\pm 3/8$ " of the size and dimensions shown on the plans, except that a minus tolerance shall not be allowed for the slotted width in which the metal post must fit.

Delete Subsection 712.16 on page 791, and substitute the following.

907-712.16--Hardware. All ferrous metal hardware for fencing such as bolts, nuts, washers, and metal straps shall be as specified on the plans and galvanizing shall not be less than 1.0 ounce per square foot of uncoated area. Aluminum coated hardware shall be coated with aluminum meeting the requirements of AASHTO M 181 for aluminum coating and at the rate of not less than 0.4 ounces per square foot of uncoated area.

Aluminum alloy hardware shall conform to the requirements of ASTM B 221 for extruded aluminum alloy 6063, T6. The finished members shall be of uniform quality.

Aluminum-zinc coated hardware shall be coated with an aluminum-zinc alloy meeting the chemical requirements and weight of coating specified for aluminum-zinc alloy coated metal gates.

MISSISSIPPI DEPARTMENT OF TRANSPORTATION

SPECIAL PROVISION NO. 907-714-3

CODE: (SP)

DATE: 08/31/2021

SUBJECT: Miscellaneous Materials

Section 714, Miscellaneous Materials, of the 2017 Edition of the Mississippi Standard Specifications for Road and Bridge Construction is hereby amended as follows.

907-714.01--Water.

907-714.01.1--General. Delete the last sentence of the second paragraph in Subsection 714.01.1 on page 794.

907-714.01.2--Water for Use in Concrete. Delete Subsection 714.01.2 on page 794, and substitute the following:

Water from municipal sources is permitted be used as mixing water in concrete, mortar, and grout without Department testing. Water from non-municipal water sources used in mixing of concrete, mortar, and grout which does not meet the requirements in Subsection 714.01.1 shall be tested for conformance as required in AASHTO M157, Table 1 and Table 2.

907-714.01.3--Water for Use in Chemically Stabilized Based. Delete the first sentence of first paragraph in Subsection 714.01.3 on page 794, and substitute the following:

Water used in the construction of bases that contain cement, lime, or other chemical additive shall be as set out in Subsection 714.01.1. Water from municipal sources is permitted to be used without testing for conformance to the requirements below. If water is not from a municipal source, it shall not contain impurities in excess of the following limits:

Delete Subsection 714.01.6 on page 795, and substitute the following.

907-714.01.6--Blank.

907-714.05--Fly Ash.

907-714.05.1--General. Delete the first sentence of the fifth paragraph in Subsection 714.05.1 on page 797.

907-714.13--Geotextiles.

907-714.13.11--Tables. Delete Table 1 in Subsection 714.13.11 on page 813, and substitute the following.

Table 1 - Geotextiles

Type Designation	I ¹ Sediment Control	II ¹ Control	III Drainage	IV Paving	V Separation & Drainage		VI Separation, Stabilization & Reinforcement		VIII High Strength	IX High Strength	Test Method
					Woven	Non-Woven	Woven	Non-Woven			
Grab Strength (lb)	50	90	110	90	200	280	180	450	280	280	ASTM D 4632
Elongation (%)	----	50% max @ 45 lb	20% min	50% min @ break	50% min	50% max	50% min	50% max	50% min	50% min	ASTM D 4632
Seam Strength (lb)	----	----	70	----	180	240	160	400	240	240	ASTM D 4632
Puncture Strength (lb)	----	----	40	----	80	110	75	180	115	115	ASTM D 6241
Trapezoidal Tear (lb)	----	----	40	----	80	100	70	150	100	100	ASTM D 4533
Asphalt Retention (gal/yd ²)	----	----	----	0.2	----	----	----	----	----	----	ASTM D 6140
Permittivity (sec ⁻¹) min	0.05	0.05	0.5	----	0.2	0.2	0.2	0.2	0.2	0.2	ASTM D 4491
AOS Woven (mm) max	0.60	0.60	0.6	----	0.6	0.43	----	0.43	----	----	ASTM D 4751
AOS Non-Woven (mm) max	0.84	0.84	0.43	----	0.43	----	0.43	----	0.43	0.43	----
Tensile Strength after UV (% Retained)	70% @ 500 hr	70% @ 500 hr	50% @ 500 hr	----	50% @ 500 hr	50% @ 500 hr	50% @ 500 hr	50% @ 500 hr	50% @ 500 hr	50% @ 500 hr	ASTM D 4355
Melting Point °(F)	----	----	----	325	----	----	----	----	----	----	ASTM D 276
Minimum Ultimate Tensile Strength ³ (lb/in)	----	----	----	----	----	----	----	----	660	2000	ASTM D 4595

Notes: 1 - All property values, with the exception of apparent opening size (AOS), represent minimum average roll values in the weakest principal direction. Values for AOS represent the maximum average roll values, 2 - Values not identified in this table should meet manufacturer certification for the use and application, 3 - Machine direction

Delete Subsection 714.15 on pages 816 and 817 and substitute the following.

907-714.15--Geogrids.

907-714.15.1--General. A geogrid is defined as a geosynthetic formed by a regular network of connected elements with apertures greater than 0.25 inch to allow interlocking with surrounding soil, rock, and other surrounding materials to function primarily as reinforcement.

Geogrid shall be manufactured from an expanded strain hardened monolithic polymer sheet composed of one or more synthetic polymers and shall be mildew resistant and inert to biological degradation and naturally encountered chemicals, alkalis and acids. The geogrid shall contain stabilizers and/or inhibitors, or a resistance finish or covering to make it resistant to deterioration from direct sunlight, ultraviolet rays, and heat.

Geogrid manufacturers shall participate in and be in compliance with the American Association of State Highway Transportation Officials (AASHTO) National Transportation Product Evaluation Program's (NTPEP) Geosynthetics audit program. Geogrid shall meet the requirements of Table II for the application and type shown on the plans and shall be selected from the Department's Approved Lists.

907-714.15.1.1--Geogrid for Retaining Walls and Reinforced Soil Slopes. Geogrid for retaining walls and reinforced soil slopes shall be creep tested in accordance with AASHTO R69 and meet Long Term Design Load, Minimum Ultimate Tensile Strength, and open area criteria listed in Table II. Manufacturers shall perform at least one long-term creep test for no less than 10,000 hours in accordance to ASTM D 5262 for each polymer or composition of polymers from which the geogrid is produced. The long-term design load that shall be reported for design use, shall be that load at which no more than 10% strain occurs over a 100-year design life of the geogrid, as calculated in accordance with AASHTO R69. Long-term design loads shall be reported unfactored, and the AASHTO strength reduction factors (Durability and Installation, and safety factors) will be considered by the Department's Geotechnical Branch on a site specific design basis.

907-714.15.1.2--Geogrid for Subgrade Stabilization. Geogrid for subgrade stabilization shall meet Minimum Ultimate Tensile Strength and open area criteria listed in Table II.

907-714.15.2--Marking, Shipment, and Storage. Each roll or container of geogrid shall be visibly labeled with the name of the manufacturer, trade name of the product, lot number, and quantity of material. In addition, each roll or container shall be clearly tagged to show the type designation that corresponds to that required by the plans. During shipment and storage the geogrid shall be protected from direct sunlight, and temperatures above 120°F or below 0°F. The geogrid shall either be wrapped and maintained in a heavy duty protective covering or stored in a safe enclosed area to protect from damage during prolonged storage.

907-714.15.3--Manufacturer Certification. The Contractor shall furnish the Engineer three copies of the manufacturer's certified test reports indicating that the geogrid furnished conforms to the requirements of the specifications and is of the same composition as the originally approved

by the Department.

907-714.15.4--Acceptance Sampling and Testing. Final acceptance of each shipment will be based upon results of tests performed by the Department on verification samples submitted from the project, as compared to the manufacturer's certified test reports. The Engineer will select one roll or container at random from each shipment for sampling. As sample extending full width of the randomly selected roll or container and being at least five (5) square yards in area will be obtained and submitted by the Engineer. All material samples shall be provided at no cost to the State.

**TABLE II
GEOGRIDS**

Physical Properties	Type Designation						Test Method
	I	II	III	IV	V	VI	
Long Term Design Load ¹ , pounds per foot, Machine Direction	250	500	750	1500	2500	3500	AASHTO R69, ASTM D5262
Minimum Ultimate Tensile Strength ² , pounds per foot, Machine Direction	500	1000	1500	3000	5000	7000	ASTM D6637
Open Area, percent	70	70	50	50	50	50	Direct Measurement

¹ Minimum design criteria requirement.

² Minimum Average Roll Value (MARV).

MISSISSIPPI DEPARTMENT OF TRANSPORTATION

SPECIAL PROVISION NO. 907-718-1

CODE: (SP)

DATE: 12/07/2021

SUBJECT: Timber and Dimension Lumber

Section 718, Timber and Dimension Lumber, of the 2017 Edition of the Mississippi Standard Specifications for Road and Bridge Construction is hereby amended as follows.

Delete the Subsections in Section 718 on pages 836 thru 838, and substitute the following.

907-718.01--General. All timber and dimension lumber shall be Southern pine and shall conform in all respects to applicable requirements of AASHTO M 168. The Department reserves the right to sample and to test all materials at any time; all inspection, testing, and certification of materials will be performed in accordance with the requirements of the current version of the Department's *Materials Division Inspection, Testing, and Certification Manual*.

Timber and dimension lumber shall be furnished in the sizes shown on the plans or as specified. Unless otherwise specified, timber and dimension lumber shall be No. 1, or better, graded according to the latest American Lumber Standards.

Only one type of preservative shall be used for the treatment of materials for any one class of construction on a project, unless otherwise specified.

Where treated timber and dimensional lumber is to be used in non-highway construction or use, such as decking, handrails in walking trails, or in any manner where general public exposure by touch is possible, the treatment requirements will be as per project plans and/or approved by the State Materials Engineer.

907-718.02--Untreated Timber and Dimension Lumber. Untreated timber and dimension lumber shall conform to the requirements of AASHTO M 168.

907-718.03--Treated Timber and Dimension Lumber. Timber and dimension lumber to be treated shall meet the requirements herein specified and shall be treated as specified. Treated timber or dimensional lumber will not be accepted for use unless it has been inspected by an authorized representative of the Department and found to be satisfactory after treatment.

907-718.03.1--Blank.

907-718.03.2--Treatment.

907-718.03.2.1--General. All materials shall be treated in accordance with AASHTO M 133 unless otherwise directed by the Environmental Protection Agency (EPA).

907-718.03.2.2--Blank.

907-718.03.2.3--Inspection. Treated timber and dimension lumber shall be inspected by an authorized representative of the Department before being incorporated into the work. Treatment reports shall be provided to the Department for each lot of material supplied.

907-718.03.3--Blank.

907-718.03.4--Storage of Treated Material. All material treated for stock shall be stacked as compactly as possible on a well-drained surface. Material shall be supported on sills spaced as necessary, not to exceed 10 foot intervals and shall have at least one foot of air space beneath the stacks.

All materials treated with preservatives for use in buildings and applications where painting is required shall be dried after treatment. The treated wood shall be dried in accordance with American Lumber Standards.

907-718.04--Preservative. Preservatives shall be as specified in AASHTO M 133 unless otherwise directed by the Environmental Protection Agency (EPA).

MISSISSIPPI DEPARTMENT OF TRANSPORTATION

SPECIAL PROVISION NO. 907-720-2

CODE: (IS)

DATE: 09/11/2018

SUBJECT: Acceptance Procedure for Glass Beads

Section 720, Pavement Marking Materials, of the 2017 Edition of the Mississippi Standard Specifications for Road and Bridge Construction is hereby amended as follows.

907-720.01--Glass Beads.

907-720.01.4--Acceptance Procedures. Delete the last sentence of the paragraph in Subsection 720.01.4 on page 841, and substitute the following.

Acceptance sampling and testing of glass beads will be in accordance with the Department's Materials Division Inspection, Testing, and Certification Manual, Section 2.9.2 -- Glass Beads.

MISSISSIPPI DEPARTMENT OF TRANSPORTATION

SPECIAL PROVISION NO. 907-721-4

CODE: (IS)

DATE: 04/19/2022

SUBJECT: Materials for Signing

Section 721, Materials for Signing, of the 2017 Edition of the Mississippi Standard Specifications for Road and Bridge Construction is hereby amended as follows.

907-721.06--Reflective Sheeting.

907-721.06.2--Performance Requirements. Delete Table 4 and Table 5 in Subsection 721.06.2 on pages 860 & 861, and substitute the following.

**MINIMUM COEFFICIENTS OF RETROREFLECTION
Candela per foot candle per square foot (cd/ft²)
Per ASTM Designation D4956**

**TABLE 4
Type IX Sheeting**

Observation Angle	Entrance Angle	White	Yellow	Green	Red	Blue	Fluorescent Yellow/Green	Fluorescent Yellow	Fluorescent Orange
0.2°	-4.0°	380	285	38	76	17	300	230	115
0.2°	+30.0°	215	162	22	43	10	170	130	65
0.5°	-4.0°	240	180	24	48	11	190	145	72
0.5°	+30.0°	135	100	14	27	6.0	110	81	41
1.0°	-4.0°	80	60	8.0	16	3.6	64	48	24
1.0°	+30.0°	45	34	4.5	9.0	2.0	36	27	14

**TABLE 5
Type XI Sheeting**

Observation Angle	Entrance Angle	White	Yellow	Green	Red	Blue	Brown	Fluorescent Yellow/Green	Fluorescent Yellow	Fluorescent Orange
0.2°	-4.0°	580	435	58	87	26	17	460	350	175
0.2°	+30.0°	220	165	22	33	10	7.0	180	130	66
0.5°	-4.0°	420	315	42	63	19	13	340	250	125
0.5°	+30.0°	150	110	15	23	7.0	5.0	120	90	45
1.0°	-4.0°	120	90	12	18	5.0	4.0	96	72	36
1.0°	+30.0°	45	34	5.0	7.0	2.0	1.0	36	27	14

After Subsection 721.10 on page 864, add the following.

907-721.11--Digital Applied Printing. The following addresses the requirements for digitally printed finished retroreflective traffic control signs on flat sheet aluminum and digitally printed traffic sign faces intended to be applied to a sign substrate.

907-721.11.1--Digitally Printed Ink Systems. Traffic signs must be produced using components, and processes that comply with the retroreflective sheeting manufacturer’s recommendations.

Digital printed ink systems used to print traffic signs must meet and comply with daytime and nighttime chromaticity (color standards) as recognized in ASTM D4956 “Standard Specification for Retroreflective Sheeting for Traffic Control.”

Digital printed ink systems must meet 70% of the initial retroreflectivity specifications of each respective reflective film color as found in ASTM D4956 “Standard Specification for Retroreflective Sheeting for Traffic Control.”

Prior to fabrication and preferably at the preconstruction meeting, the Contractor shall advise the Project Engineer in writing as to which signs on the project will be digitally printed and which ones will be screen printed. The Contractor shall submit to the Project Engineer certifications for all digitally printed signs, which will be forwarded to the State Traffic Engineer for review.

907-721.11.2--Protective Overlay Film. Permanent traffic signs printed with digital ink systems will be fabricated with a full sign protective overlay film designed to provide a smooth surface needed for retroreflectivity, and to protect the sign from fading and UV degradation. The overlamine shall comply with the retroreflective sheeting manufacturer’s recommendations to ensure proper adhesion and transparency and will also meet the reflective film durability as identified in Table 1.

**Table 1
Retroreflective Film Minimum Durability Requirements**

ASTM D4956 Type	Full Sign Replacement Term (years)	Sheeting Replacement Term (years)
IV	7	10
VIII	7	10
IX	7	12
XI	7	12

Temporary signs used in work zones printed with black ink only will not require a protective overlay film as long as the finished sign is warranted for a minimum outdoor durability of three years by the sheeting manufacturer.

907-721.11.3--Inspection. During fabrication, the Contractor shall provide sufficient testing and quality control throughout fabrication to insure good workmanship. Once the material has been received, it may be subject to random testing to ensure compliance with all requirements. If any test samples do not conform to the requirements, the entire order may be returned at the vendor’s expense.

907-721.11.4--Traffic Sign Performance Warranty Provisions. Based on the ASTM Type of sheeting specified, traffic control signs shall be warranted for the duration shown in Table 1. The Contractor shall supply a copy of the warranty document with complete details of terms and conditions upon request of the Department.

907-721.11.5--Certified Digital Sign Fabricator. Sign fabricators using digital imaging methods to produce regulated traffic signs must be certified by the reflective sheeting manufacturer whose materials are used to produce the delivered signs.

Certified sign fabricators must undergo an audit process by the sheeting manufacturer to ensure they have the proper equipment, manufacturing capabilities, manufacturing application processes and the materials required to fulfill the sheeting manufacturer's warranty obligations. Sign fabricators must recertify annually with reflective sheeting manufacturers or utilize a 3rd party certifier approved by the reflective sheeting manufacturer.

The Contractor shall submit proof of Sign Fabricator Certification as issued by the retroreflective sign sheeting manufacturer to the Project Engineer upon delivery of the signs, or with the Shop Drawings.

SECTION 905 - PROPOSAL

Date _____

Mississippi Transportation Commission
Jackson, Mississippi

Sirs: The following proposal is made on behalf of _____
_____ of _____

for constructing the following designated project(s) within the time(s) hereinafter specified.

The plans are composed of drawings and blue prints on file in the offices of the Mississippi Department of Transportation, Jackson, Mississippi.

The Specifications are the current Standard Specifications of the Mississippi Department of Transportation approved by the Federal Highway Administration, except where superseded or amended by the plans, Special Provisions and Notice(s) to Bidders attached hereto and made a part thereof.

I (We) certify that I (we) possess a copy of said Standard and any Supplemental Specifications.

Evidence of my (our) authority to submit the Proposal is hereby furnished. The proposal is made without collusion on the part of any person, firm or corporation. I (We) certify that I (we) have carefully examined the Plans, the Specifications, including the Special Provisions and Notice(s) to Bidders, herein, and have personally examined the site of the work. On the basis of the Specifications, Special Provisions, Notice(s) to Bidders, and Plans, I (we) propose to furnish all necessary machinery, tools, apparatus and other means of construction and do all the work and furnish all the materials in the manner specified. I (We) understand that the quantities mentioned herein are approximate only and are subject to either increase or decrease, and hereby propose to perform any increased or decreased quantities of work at the unit prices bid, in accordance with the above.

I (We) acknowledge that this proposal will be found irregular and/or non-responsive unless a certified check, cashier's check, or Proposal Guaranty Bond in the amount as required in the Advertisement (or, by law) is submitted electronically with the proposal or is delivered to the Contract Administration Engineer prior to the bid opening time specified in the advertisement.

INSTRUCTION TO BIDDERS: Alternate and Optional Items on Bid Schedule.

1. Two or more items entered opposite a single unit quantity WITHOUT DEFINITE DESIGNATION AS "ALTERNATE ITEMS" are considered as "OPTIONAL ITEMS". Bidders may or may not indicate on bids the Optional Item proposed to be furnished or performed WITHOUT PREJUDICE IN REGARD TO IRREGULARITY OF BIDS.
2. Items classified on the bid schedule as "ALTERNATE ITEMS" and/or "ALTERNATE TYPES OF CONSTRUCTION" must be preselected and indicated on bids. However, "Alternate Types of Construction" may include Optional Items to be treated as set out in Paragraph 1, above.
3. Optional items not preselected and indicated on the bid schedule MUST be designated in accordance with Subsection 102.06 prior to or at the time of execution of the contract.
4. Optional and Alternate items designated must be used throughout the project.

I (We) further propose to perform all "force account or extra work" that may be required of me (us) on the basis provided in the Specifications and to give such work my (our) personal attention in order to see that it is economically performed.

I (We) further propose to execute the attached contract agreement (Section 902) as soon as the work is awarded to me (us), and to begin and complete the work within the time limit(s) provided for in the Specifications and Advertisement. I (We) also propose to execute the attached contract bond (Section 903) in an amount not less than one hundred (100) percent of the total of my (our) part, but also to guarantee the excellence of both workmanship and materials until the work is finally accepted.

I (We) shall submit electronically with our proposal or deliver prior to the bid opening time a certified check, cashier's check or bid bond for **five percent (5%) of total bid** and hereby agree that in case of my (our) failure to execute the contract and furnish bond within Ten (10) days after notice of award, the amount of this check (bid bond) will be forfeited to the State of Mississippi as liquidated damages arising out of my (our) failure to execute the contract as proposed. It is understood that in case I am (we are) not awarded the work, the check will be returned as provided in the Specifications.

SECTION 905 -- PROPOSAL (CONTINUED)

I (We) hereby certify by digital signature and electronic submission via Bid Express of the Section 905 proposal below, that all certifications, disclosures and affidavits incorporated herein are deemed to be duly executed in the aggregate, fully enforceable and binding upon delivery of the bid proposal. I (We) further acknowledge that this certification shall not extend to the bid bond or alternate security which must be separately executed for the benefit of the Commission. This signature does not cure deficiencies in any required certifications, disclosures and/or affidavits. I (We) also acknowledge the right of the Commission to require full and final execution on any certification, disclosure or affidavit contained in the proposal at the Commission's election upon award. Failure to so execute at the Commission's request within the time allowed in the Standard Specifications for execution of all contract documents will result in forfeiture of the bid bond or alternate security.

Respectfully Submitted,

DATE _____

Contractor

BY _____
Signature

TITLE _____

ADDRESS _____

CITY, STATE, ZIP _____

PHONE _____

FAX _____

E-MAIL _____

(To be filled in if a corporation)

Our corporation is chartered under the Laws of the State of _____ and the names, titles and business addresses of the executives are as follows:

President Address

Secretary Address

Treasurer Address

The following is my (our) itemized proposal.

Full Depth Reclamation & DBST approximately 10 miles of SR 316 from the BOSM in Jonestown to SR 6 / US 278, known as State Project Nos. SP-0835-00(006) / 109224301 & SP-0835-00(007) / 109224302 in Coahoma & Quitman Counties.

Line no.	Item Code	Adj Code	Quantity	Units	Description[Fixed Unit Price]
Roadway Items					
0010	202-B213		84	Each	Removal of Sign
0020	202-B240		1,395	Linear Feet	Removal of Traffic Stripe
0030	618-A001		1	Lump Sum	Maintenance of Traffic
0040	618-B001		2	Square Feet	Additional Construction Signs (\$10.00)
0050	619-A1001		44	Mile	Temporary Traffic Stripe, Continuous White
0060	619-A2001		24	Mile	Temporary Traffic Stripe, Continuous Yellow
0070	619-A4002		12	Mile	Temporary Traffic Stripe, Skip Yellow
0080	620-A001		1	Lump Sum	Mobilization
0090	626-C002		22	Mile	6" Thermoplastic Double Drop Edge Stripe, Continuous White
0100	626-D001		6	Mile	6" Thermoplastic Double Drop Traffic Stripe, Skip Yellow
0110	626-E001		13	Mile	6" Thermoplastic Double Drop Traffic Stripe, Continuous Yellow
0120	626-G004		600	Linear Feet	Thermoplastic Double Drop Detail Stripe, White
0130	626-H002		280	Linear Feet	Thermoplastic Double Drop Legend, White
0140	627-J001		173	Each	Two-Way Clear Reflective High Performance Raised Markers
0150	627-L001		914	Each	Two-Way Yellow Reflective High Performance Raised Markers
0160	630-A001		174	Square Feet	Standard Roadside Signs, Sheet Aluminum, 0.080" Thickness
0170	630-A003		466	Square Feet	Standard Roadside Signs, Sheet Aluminum, 0.125" Thickness
0180	630-A005		208	Square Feet	Standard Roadside Signs, Sheet Aluminum, 0.1" Thickness
0190	630-C005		1,545	Linear Feet	Square Tube Posts, 2.0 lb/ft
0200	630-G004		8	Each	Type 3 Object Markers, OM-3R or OM-3L
0210	699-A001		1	Lump Sum	Roadway Construction Stakes
0220	907-410-A002	(A2)	131,225	Gallon	Asphalt for Surface Treatment, Grade CRS-2P
0230	907-410-B001	(GY)	1,485	Cubic Yard	Seal Aggregate Cover Material, Size 7, Limestone
0240	907-410-B002	(GY)	1,375	Cubic Yard	Seal Aggregate Cover Material, Size 89, Limestone
0250	907-414-B001	(A2)	16,400	Gallon	Asphalt for Fog Seal
0260	907-424-A001		133,770	Square Yard	Roadbed Reclamation with Cement
0270	907-424-B001		2,550	Ton	Cement
0280	907-619-E3001		2	Each	Changeable Message Sign

SECTION 905 - COMBINATION BID PROPOSAL (Continued)

CONDITIONS FOR COMBINATION BID

If a bidder elects to submit a combined bid for two or more of the contracts listed for this month's letting, the bidder must complete and execute these sheets of the proposal in each of the individual proposals to constitute a combination bid. In addition to this requirement, each individual contract shall be completed, executed and submitted in the usual specified manner.

Failure to execute this Combination Bid Proposal in each of the contracts combined will be just cause for each proposal to be received and evaluated as a separate bid.

It is understood that the Mississippi Transportation Commission not only reserves the right to reject any and all proposals, but also the right to award contracts upon the basis of lowest separate bids or combination bids most advantageous to the State.

It is further understood and agreed that the Combination Bid Proposal is for comparison of bids only and that each contract shall operate in every respect as a separate contract in accordance with its proposal and contract documents.

I (We) agree to complete each contract on or before its specified completion date.

COMBINATION BID PROPOSAL

This proposal is tendered as one part of a Combination Bid Proposal utilizing option ___* of Subsection 102.11 on the following contracts:

* Option to be shown as either (a), (b), or (c).

	<u>Project No.</u>	<u>County</u>	<u>Project No.</u>	<u>County</u>
1.	_____	_____	6.	_____
2.	_____	_____	7.	_____
3.	_____	_____	8.	_____
4.	_____	_____	9.	_____
5.	_____	_____	10.	_____

(a) If Combination A has been selected, your Combination Bid is complete.

(b) If Combination B has been selected, then complete the following page.

SECTION 905 - COMBINATION BID PROPOSAL (Continued)

Project Number	Pay Item Number	Unit	Unit Price Reduction	Total Item Reduction	Total Contract Reduction
1.					
2.					
3.					
4.					
5.					
6.					
7.					
8.					

For Informational Purposes Only

SECTION 905 - COMBINATION BID PROPOSAL (Continued)

Project Number	Pay Item Number	Unit	Unit Price Reduction	Total Item Reduction	Total Contract Reduction
9.					
10.					

(c) If Combination C has been selected, then initial and complete ONE of the following.

_____ I (We) desire to be awarded work not to exceed a total monetary value of \$ _____.

_____ I (We) desire to be awarded work not to exceed _____ number of contracts.



TO: EXECUTIVE DIRECTOR, MISSISSIPPI DEPARTMENT OF TRANSPORTATION
JACKSON, MISSISSIPPI

CERTIFICATE

If awarded this contract, I (we) contemplate that portions of the contract will be sublet. I (we) certify that those subcontracts which are equal to or in excess of fifty thousand dollars (\$50,000.00) will be in accordance with regulations promulgated and adopted by the Mississippi State Board of Contractors on September 8, 2011.

I (we) agree that this notification of intent DOES NOT constitute APPROVAL of the subcontracts.

_____	_____
(Individual or Firm)	(Address)
_____	_____
(Individual or Firm)	(Address)
_____	_____
(Individual or Firm)	(Address)
_____	_____
(Individual or Firm)	(Address)

NOTE: Failure to complete the above DOES NOT preclude subsequent subcontracts. Subsequent subcontracts, if any, equal to or in excess of fifty thousand dollars (\$50,000.00) will be in accordance with regulations promulgated and adopted by the Mississippi State Board of Contractors on September 8, 2011.

Contractor _____

MISSISSIPPI DEPARTMENT OF TRANSPORTATION
CERTIFICATION

I, _____,
(Name of person signing bid)

individually, and in my capacity as _____ of
(Title of person signing bid)

(Name of Firm, partnership, or Corporation)

do hereby certify under penalty of perjury under the laws of the United States and the State of Mississippi

that _____, Bidder
(Name of Firm, Partnership, or Corporation)

on Project No. **SP-0835-00(006)/ 109224301000 & SP-0835-00(007)/ 109224302000**

in **Coahoma & Quitman** County(ies), Mississippi, has not either directly or indirectly entered into any agreement, participated in any collusion; or otherwise taken any action in restraint of free competitive bidding in connection with this contract; nor have any of its corporate officers or principal owners.

Except as noted hereafter, it is further certified that said legal entity and its corporate officers, principal owners, managers, auditors and others in a position of administering federal funds are not currently under suspension, debarment, voluntary exclusion or determination of ineligibility; nor have a debarment pending; nor been suspended, debarred, voluntarily excluded or determined ineligible within the past three years by the Mississippi Transportation Commission, the State of Mississippi, any other State or a federal agency; nor been indicted, convicted or had a civil judgment rendered by a court of competent jurisdiction in any matter involving fraud or official misconduct within the past three years.

Do exceptions exist and are made a part thereof? Yes / No

Any exceptions shall address to whom it applies, initiating agency and dates of such action.

Note: Exceptions will not necessarily result in denial of award but will be considered in determining bidder responsibility. Providing false information may result in criminal prosecution or administrative sanctions.

All of the foregoing is true and correct.

(1/2016 S)

SECTION 902

CONTRACT FOR SP-0835-00(006)/ 109224301000 & SP-0835-00(007)/ 109224302000

LOCATED IN THE COUNTY(IES) OF Coahoma & Quitman

STATE OF MISSISSIPPI,
COUNTY OF HINDS

This contract entered into by and between the Mississippi Transportation Commission on one hand, and the undersigned contractor, on the other witnesseth;

That, in consideration of the payment by the Mississippi Transportation Commission of the prices set out in the proposal hereto attached, to the undersigned contractor, such payment to be made in the manner and at the time of times specified in the specifications and the special provisions, if any, the undersigned contractor hereby agrees to accept the prices stated in the proposal in full compensation for the furnishing of all materials and equipment and the executing of all the work contemplated in this contract.

It is understood and agreed that the advertising according to law, the Advertisement, the instructions to bidders, the proposal for the contract, the specifications, the revisions of the specifications, the special provisions, and also the plans for the work herein contemplated, said plans showing more particularly the details of the work to be done, shall be held to be, and are hereby made a part of this contract by specific reference thereto and with like effect as if each and all of said instruments had been set out fully herein in words and figures.

It is further agreed that for the same consideration the undersigned contractor shall be responsible for all loss or damage arising out of the nature of the work aforesaid; or from the action of the elements and unforeseen obstructions or difficulties which may be encountered in the prosecution of the same and for all risks of every description connected with the work, exceptions being those specifically set out in the contract; and for faithfully completing the whole work in good and workmanlike manner according to the approved Plans, Specifications, Special Provisions, Notice(s) to Bidders and requirements of the Mississippi Department of Transportation.

It is further agreed that the work shall be done under the direct supervision and to the complete satisfaction of the Executive Director of the Mississippi Department of Transportation, or his authorized representatives, and when Federal Funds are involved subject to inspection at all times and approval by the Federal Highway Administration, or its agents as the case may be, or the agents of any other Agency whose funds are involved in accordance with those Acts of the Legislature of the State of Mississippi approved by the Governor and such rules and regulations issued pursuant thereto by the Mississippi Transportation Commission and the authorized Federal Agencies.

The Contractor agrees that all labor as outlined in the Special Provisions may be secured from list furnished by

It is agreed and understood that each and every provision of law and clause required by law to be inserted in this contract shall be deemed to be inserted herein and this contract shall be read and enforced as though it were included herein, and, if through mere mistake or otherwise any such provision is not inserted, then upon the application of either party hereto, the contract shall forthwith be physically amended to make such insertion.

The Contractor agrees that he has read each and every clause of this Contract, and fully understands the meaning of same and that he will comply with all the terms, covenants and agreements therein set forth.

Witness our signatures this the ___ day of _____, _____.

Contractor(s)

By _____

MISSISSIPPI TRANSPORTATION COMMISSION

Title _____

By _____

Signed and sealed in the presence of:
(names and addresses of witnesses)

Executive Director

Secretary to the Commission

Award authorized by the Mississippi Transportation Commission in session on the ___ day of _____, _____, Minute Book No. _____, Page No. _____.

SECTION 903
PERFORMANCE AND PAYMENT BOND

CONTRACT BOND FOR: SP-0835-00(006)/ 109224301000 & SP-0835-00(007)/ 109224302000

LOCATED IN THE COUNTY(IES) OF: Coahoma & Quitman

STATE OF MISSISSIPPI,
COUNTY OF HINDS

Know all men by these presents: that we, _____
(Contractor)
_____ Principal, a _____

residing at _____ in the State of _____

and _____

(Surety)
residing at _____ in the State of _____,

authorized to do business in the State of Mississippi, under the laws thereof, as surety, effective as of the contract date shown below, are held and firmly bound unto the State of Mississippi in the sum of _____

_____ Dollars, lawful money of the United States of America, to be paid to it for which payment well and truly to be made, we bind ourselves, our heirs, administrators, successors, or assigns jointly and severally by these presents.

The conditions of this bond are such, that whereas the said _____

_____ principal, has (have) entered into a contract with the Mississippi Transportation Commission, bearing the date of _____ day of _____ A.D. _____ hereto annexed, for the construction of certain projects(s) in the State of Mississippi as mentioned in said contract in accordance with the Contract Documents therefor, on file in the offices of the Mississippi Department of Transportation, Jackson, Mississippi.

Now therefore, if the above bounden _____ in all things shall stand to and abide by and well and truly observe, do keep and perform all and singular the terms, covenants, conditions, guarantees and agreements in said contract, contained on his (their) part to be observed, done, kept and performed and each of them, at the time and in the manner and form and furnish all of the material and equipment specified in said contract in strict accordance with the terms of said contract which said plans, specifications and special provisions are included in and form a part of said contract and shall maintain the said work contemplated until its final completion and acceptance as specified in Subsection 109.11 of the approved specifications, and save harmless said Mississippi Transportation Commission from any loss or damage arising out of or occasioned by the negligence, wrongful or criminal act, overcharge, fraud, or any other loss or damage whatsoever, on the part of said principal (s), his (their) agents, servants, or employees in the performance of said work or in any manner connected therewith, and shall be liable and responsible in a civil action instituted by the State at the instance of the Mississippi Transportation Commission or any officer of the State authorized in such cases, for double any amount in money or property, the State may lose or be overcharged or otherwise defrauded of, by reason of wrongful or criminal act, if any, of the Contractor(s), his (their) agents or employees, and shall promptly pay the said agents, servants and employees and all persons furnishing labor, material, equipment or supplies therefor, including premiums incurred, for Surety Bonds, Liability Insurance, and Workmen's Compensation Insurance; with the additional obligation that such Contractor shall promptly make payment of all taxes, licenses, assessments, contributions, damages,

any liquidated damages which may arise prior to any termination of said principal's contract, any liquidated damages which may arise after termination of the said principal's contract due to default on the part of said principal, penalties and interest thereon, when and as the same may be due this state, or any county, municipality, board, department, commission or political subdivision: in the course of the performance of said work and in accordance with Sections 31-5-51 et seq. Mississippi Code of 1972, and other State statutes applicable thereto, and shall carry out to the letter and to the satisfaction of the Executive Director of the Mississippi Department of Transportation, all, each and every one of the stipulations, obligations, conditions, covenants and agreements and terms of said contract in accordance with the terms thereof and all of the expense and cost and attorney's fee that may be incurred in the enforcement of the performance of said contract, or in the enforcement of the conditions and obligations of this bond, then this obligation shall be null and void, otherwise to be and remain in full force and virtue.

_____	_____
(Contractors) Principal	Surety
By _____	By _____
	(Signature) Attorney in Fact
	Address _____

Title _____	_____
(Contractor's Seal)	(Printed) MS Agent

	(Signature) MS Agent
	Address _____

	(Surety Seal)

	Mississippi Insurance ID Number



BID BOND

KNOW ALL MEN BY THESE PRESENTS, that we _____
Contractor

Address

City, State ZIP

As principal, hereinafter called the Principal, and _____
Surety

a corporation duly organized under the laws of the state of _____

as Surety, hereinafter called the Surety, are held and firmly bound unto State of Mississippi, Jackson, Mississippi

As Obligee, hereinafter called Obligee, in the sum of **Five Per Cent (5%) of Amount Bid**

Dollars(\$ _____)

for the payment of which sum will and truly to be made, the said Principal and said Surety, bind ourselves, our heirs, executors, administrators, successors and assigns, jointly and severally, firmly by these presents.

WHEREAS, the Principal has submitted a bid for **Full Depth Reclamation & DBST approximately 10 miles of SR 316 from the BOSM in Jonestown to SR 6 / US 278, known as State Project Nos. SP-0835-00(006) / 109224301 & SP-0835-00(007) / 109224302 in Coahoma & Quitman Counties.**

NOW THEREFORE, the condition of this obligation is such that if the aforesaid Principal shall be awarded the contract, the said Principal will, within the time required, enter into a formal contract and give a good and sufficient bond to secure the performance of the terms and conditions of the contract, then this obligation to be void; otherwise the Principal and Surety will pay unto the Obligee the difference in money between the amount of the bid of the said Principal and the amount for which the Obligee legally contracts with another party to perform the work if the latter amount be in excess of the former, but in no event shall liability hereunder exceed the penal sum hereof.

Signed and sealed this _____ day of _____, 20__

(Principal)

(Seal)

(Witness) (Name) By: _____ (Title)

(Surety) (Seal)

(Witness) (Attorney-in-Fact) By: _____

(MS Agent)

Mississippi Insurance ID Number

