

STATE OF MISSISSIPPI
MISSISSIPPI DEPARTMENT OF TRANSPORTATION

DISTRICT ONE WELCOME CENTER
RENOVATIONS

STATE PROJ. NO.S BWO-1182-02(002), BWO-1181-29(004)

ALCORN & ITAWAMBA
COUNTIES

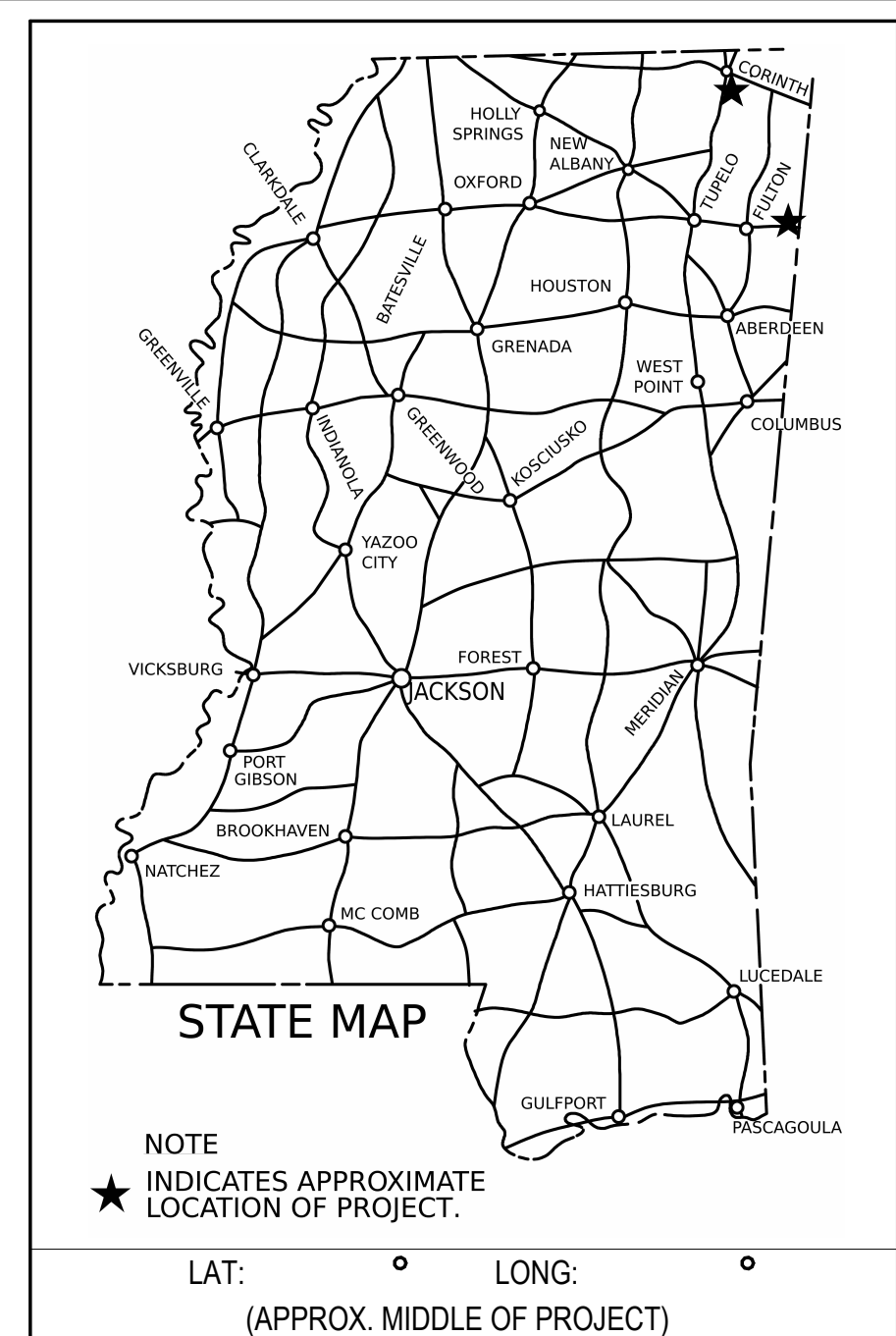

PERMITS ACQUIRED
BY MDOT

WETLANDS AND WATERS PERMITS		
	WATERS	WETLANDS
NATIONWIDE #14	N	N
NATIONWIDE (OTHER)*	N	N
GENERAL *	N	N
INDIVIDUAL (404)*	N	N
STORMWATER PERMIT		N
Y	REQUIRED. CNOI SUBMITTED BY MDOT (DISTURBED AREA=5 ACRES)	
S	REQUIRED. SCNOI TO BE SUBMITTED BY CONTRACTOR (1 TO 4.99 ACRES)	
N	NO STORMWATER PERMIT REQUIRED (<1 ACRE)	
APPROVED BY:		

CONSTRUCTION PROJECT DATA

EXTERNAL PROJ. NO.	FMS & DETAIL
BWO-1182-02(002) BWO-1181-29(004)	503757/301000 503757/302000



ARCHITECTURAL

P S & E DATE: 5-9-2024

APPROVED:

DEPUTY EXECUTIVE DIRECTOR / CHIEF ENGINEER

EXECUTIVE DIRECTOR



PROJECT LOCATION

34.91059, -88.54256

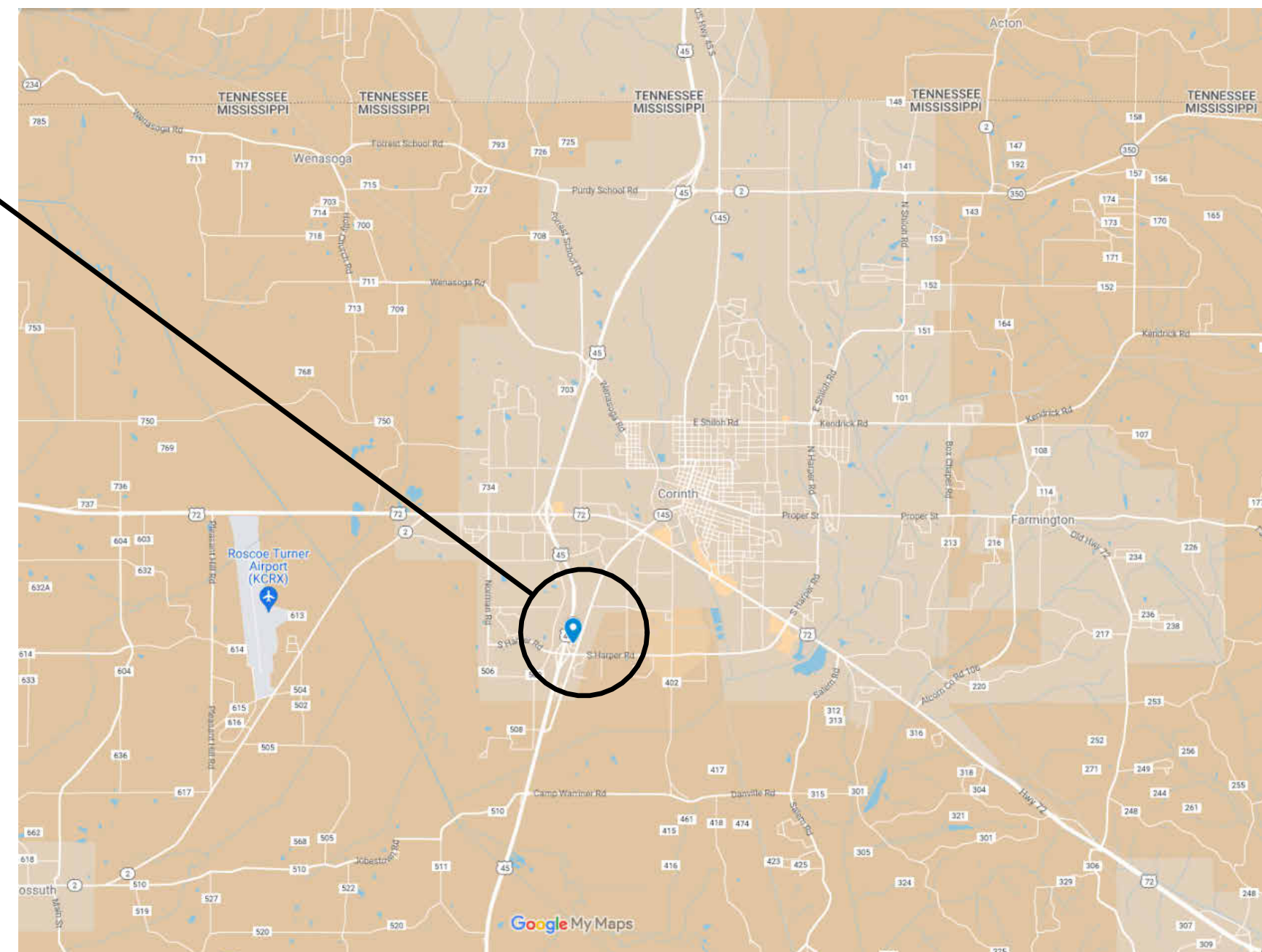

ALCORN

PROJECT LOCATION

34.22184, -88.23289

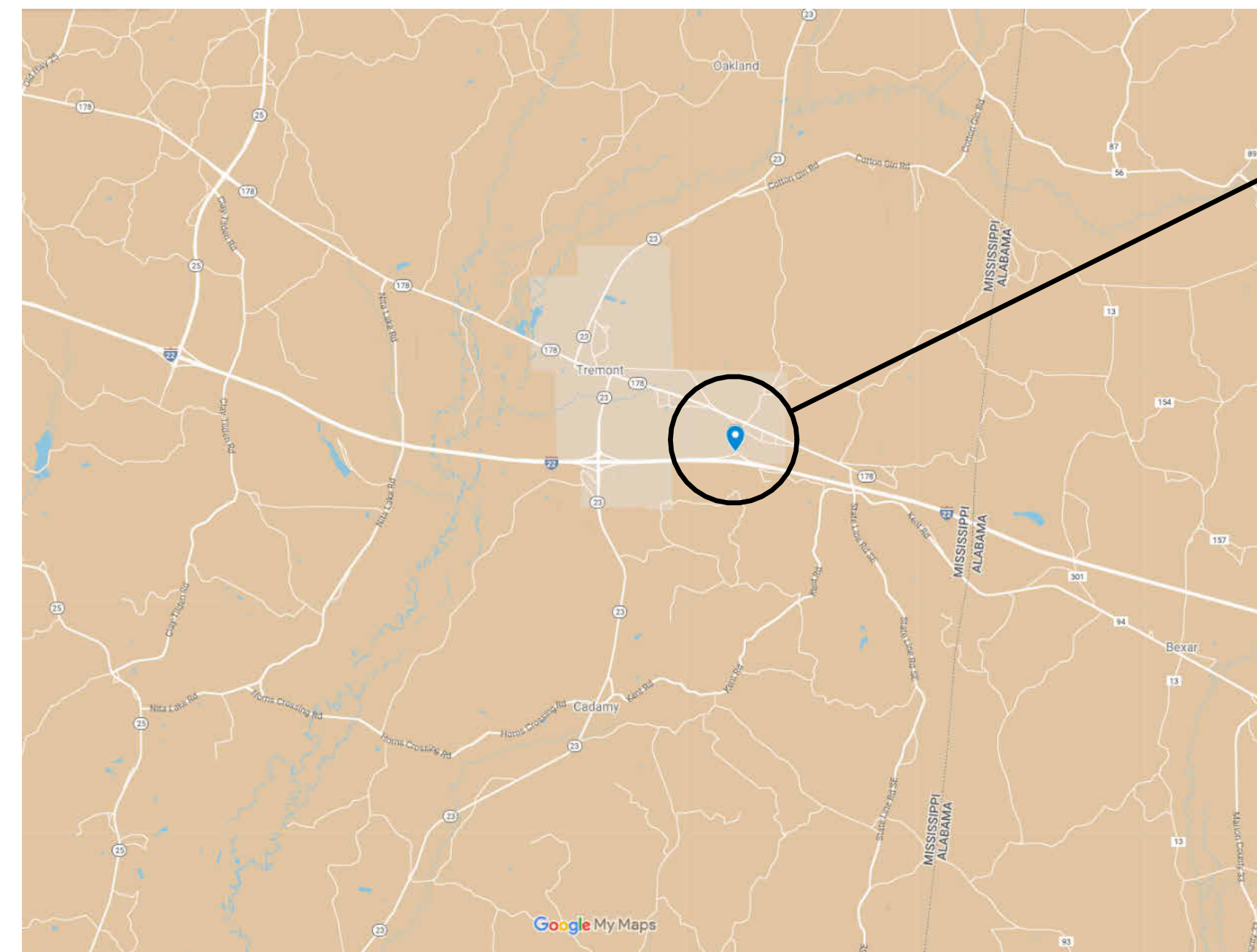

ITAWAMBA

DISTRICT ONE WELCOME CENTER RENOVATIONS ALCORN, ITAWAMBA

ALCORN NOTES

- 1 REMOVE DOOR AND REPLACE WITH NEW DOOR AND HARDWARE. SEE SPECIFICATION.
- 2 REMOVE SURFACE MOUNTED ELECTRICAL
- 3 REMOVE CURTAIN RODS AND PATCH HOLES.
- 4 REPLACE DRINKING FOUNTAIN (OWNER FURNISHED)
- 5 REPLACE TOILET PARTITIONS AND ADD URINAL SCREENS. SEE SPECIFICATION.
- 6 REPLACE THREE (3) HAND DRYERS WITH BRADLEY MODEL 2923-28W001 OR APPROVED EQUAL.
- 7 REFINISH EXISTING WOOD DOORS, REMOVE HARDWARE, CLEAN, AND REUSE. SAND, STAIN, AND APPLY POLYURETHANE FINISH. SEE PAINT SPECIFICATION. REINSTALL DOOR AND HARDWARE.
- 8 RECOVER EXISTING LAMINATE COUNTERTOP WITH NEW PLASTIC LAMINATE. SEE SPECIFICATION.
- 9 PRESSURE WASH EXTERIOR OF BUILDING. COMPLETELY REMOVE ALL MOLD, MILDEW, AND OTHER FOREIGN SUBSTANCES
- 10 CLEAN RESTROOM WALL AND FLOOR TILE AND GROUT.
- 11 PAINT ALL PREVIOUSLY PAINTED SURFACES (INTERIOR AND EXTERIOR). REFER TO COLOR DESIGN SPECIFICATION AND PAINT SPECIFICATION
- 12 CAULK WINDOWS AND RE-PUTTY MUNTINS AT GLAZING AS NEEDED.
- 13 PAINT ALL PREVIOUSLY PAINTED EXTERIOR SURFACES. REFER TO COLOR DESIGN SPECIFICATION AND PAINT SPECIFICATION
- 14 STRIP WAX FROM BRICK FLOORS. CLEAN AND SEAL BRICK.
- 15 PAINT INTERIOR BRICK WALLS. REFER TO COLOR DESIGN SPECIFICATION AND PAINT SPECIFICATION
- 16 SANDBLAST CONCRETE PICNIC TABLES SMOOTH AND REPAINT. SEE PAINT SPECIFICATION.
- 17 INSTALL NEW LITERATURE RACKS AS DIRECTED. (OWNER FURNISHED)
- 18 INSTALL PETWAY STATIONS AS DIRECTED. (OWNER FURNISHED)
- 19 REMOVE UNUSED SURFACE MOUNTED TV AND CABLES AS DIRECTED. PATCH HOLES PRIOR TO PAINTING.
- 20 PRESSURE WASH PICNIC PAVILIONS AND GUARD HOUSE AND PAINT ALL PREVIOUSLY PAINTED SURFACES. SEE PAINT SPECIFICATION.
- 21 ALL SALVAGE ITEMS TO BE REMOVED CAREFULLY AND RETURNED TO OWNER.

ALCORN ELECTRICAL NOTES

- A REPLACE CHANDELIER WITH OWNER FURNISHED 8 BULB CHANDELIER FIXTURE. PROVIDE (8) 6 WATT LED CANDELABRA BULBS. MOUNT FIXTURE 9' - 0" A.F.F.
- B REPLACE CHANDELIER WITH OWNER FURNISHED 6 BULB CHANDELIER FIXTURE. PROVIDE (6) 6 WATT LED CANDELABRA BULBS. MOUNT FIXTURE 9' - 0" A.F.F.
- C PROVIDE AND INSTALL A DEDICATED 110V-15AMP CIRCUIT FROM EXISTING PANEL (VERIFY AVAILABLE SPACE IN PANEL) TO VIDEO WALL LOCATION AS SHOWN ON PLANS (VIDEO WALL PROVIDED AND INSTALLED BY OTHERS). FLEXIBLE METAL CONDUIT ALLOWED IN CONCEALED SPACES (PROVIDE GROUND CONDUCTOR). STRAP AS PER NEC.
- D DROP POWER CIRCUIT FROM J-BOX (IN ATTIC SPACE) THRU CEILING WITH 14 GAUGE, 3-CONDUCTOR S/O CORD ON THIS SIDE OF WALL, THEN ROUTE THRU WALL AT 72" A.F.F. ROUTE IN LEAST CONSPICUOUS LOCATION POSSIBLE. STRAP CORD TO WALL AS REQUIRED.
- E TERMINATE S/O CORD ON THIS SIDE OF WALL WITH A STRAIGHT BLADE CONNECTOR, 15 AMP, 125 V, NEMA 5-15R, 2P, 3W, BLACK. PROVIDE 12" PIGTAIL FROM WALL TO END OF CORD.
- F DATA LOCATION AT 72" A.F.F. FOR VIDEO WALL. DATA CABLING PROVIDED AND INSTALLED BY OTHERS.
- G PROVIDE AND INSTALL DATA OUTLET BOX EQUAL TO WIREMOLD SURE-SNAP 400 SERIES (#2348S-51) WITH APPROPRIATE COVER PLATE AT THIS LOCATION FOR INFORMATION KIOSK (KIOSK PROVIDED BY OTHERS), AND/OR WORK DESKS (WORK DESKS PROVIDED BY OTHERS). MOUNT BOX DIRECTLY ABOVE BASE MOULDING. PROVIDE WIREMOLD SERIES 400 RACEWAY #400BAC OR EQUAL. INSTALL RACEWAY IN LEAST CONSPICUOUS LOCATION, SUCH AS IN CORNERS AND ALONG TOP OF BASE MOULDING. AVOID ROUTING ON OPEN WALLS. (DATA CABLE TO BE PROVIDED AND INSTALLED BY OTHERS.)

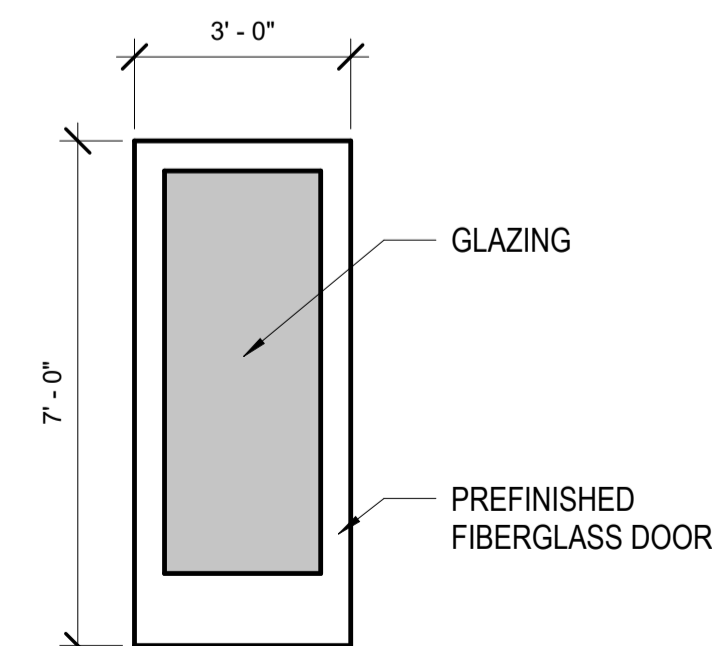

1 ENTRY DOOR ELEVATION
3/8" = 1'-0"

ELEC/DATA LEGEND
1/4" = 1'-0"

- CONDUIT DROP
- ▽ DATA OUTLET
- STRAIGHT BLADE CONNECTOR

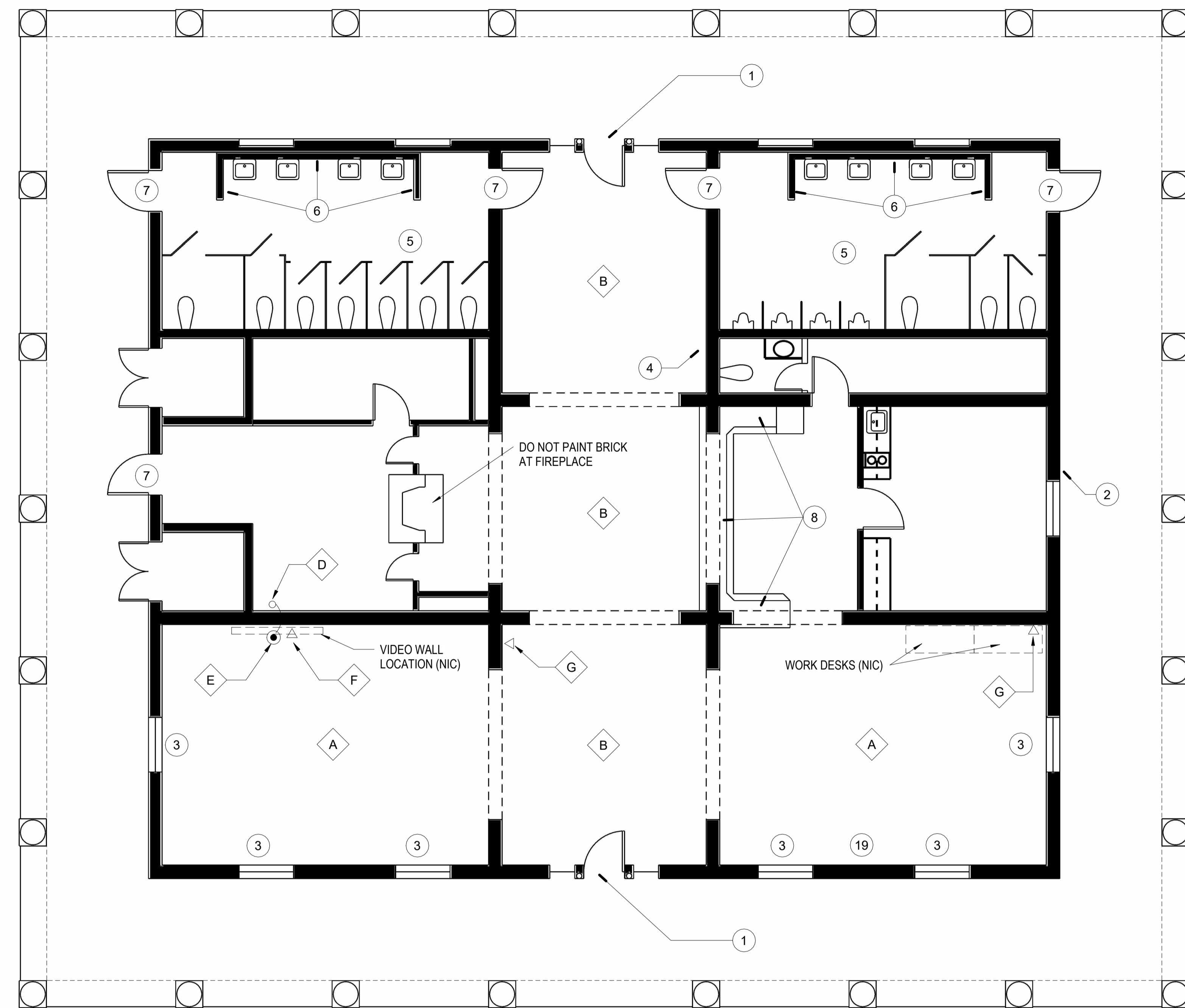

ALCORN WELCOME CENTER FLOOR PLAN

3/16" = 1'-0"

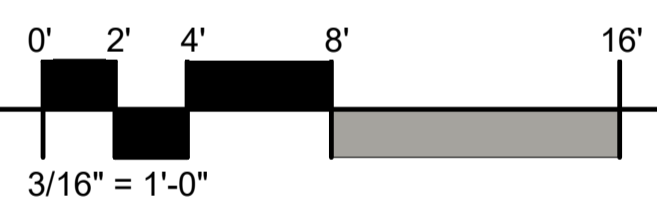

1 B

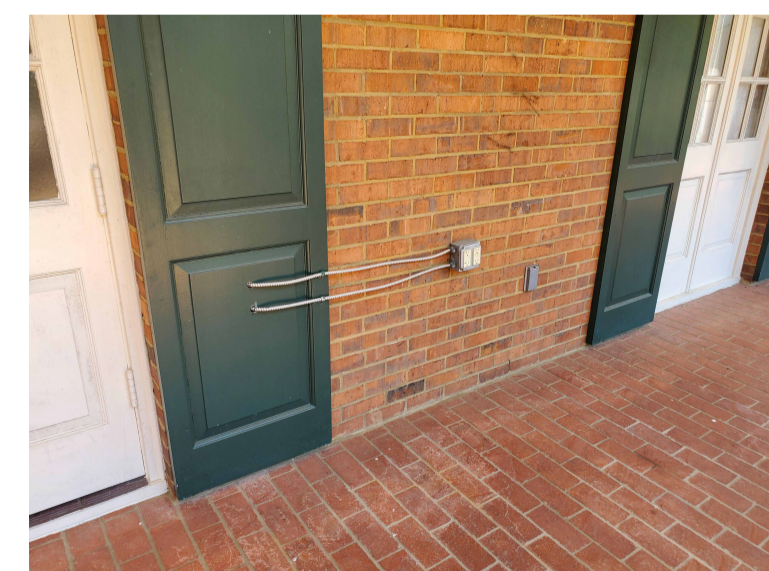

2

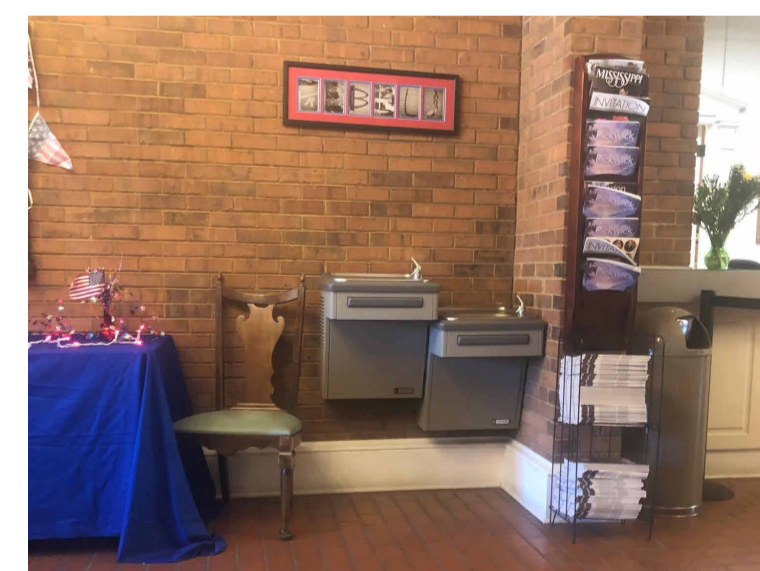

4



5



7



16



20



No.	Description	Date	Issued by

DESIGNED BY: ASU
 DETAILED BY: SMW
 CHECKED BY: JRP
 DATE: 5-9-2024

ALCORN CO. WELCOME CENTER BUILDING

DISTRICT ONE WELCOME CENTER RENOVATIONS
 ALCORN, ITAWAMBA



No.	Description	Date	Issued by

DESIGNED BY: ASU
 DETAILED BY: SMW
 CHECKED BY: JRP
 DATE: 5-9-2024

ITAWAMBA CO. WELCOME CENTER BUILDING

ITAWAMBA NOTES

- 1 REMOVE DOOR AND REPLACE WITH NEW DOOR AND HARDWARE. SEE SPECIFICATION.
- 2 REMOVE CURTAIN RODS AND PATCH HOLES.
- 3 REPLACE DRINKING FOUNTAIN (OWNER FURNISHED)
- 4 EXISTING DOOR - REMOVE HARDWARE, CLEAN, AND REUSE. PREP AND PAINT EXISTING DOOR. SEE SPECIFICATION. REINSTALL DOOR AND HARDWARE.
- 5 RECOVER EXISTING LAMINATE COUNTERTOP WITH NEW PLASTIC LAMINATE. SEE SPECIFICATION.
- 6 PRESSURE WASH EXTERIOR OF BUILDING. COMPLETELY REMOVE ALL MOLD, MILDEW, AND OTHER FOREIGN SUBSTANCES
- 7 REPLACE THREE (3) HAND DRYERS WITH BRADLEY MODEL 2923-28W001 OR APPROVED EQUAL.
- 8 CLEAN RESTROOM WALL AND FLOOR TILE AND GROUT.
- 9 PAINT ALL PREVIOUSLY PAINTED SURFACES (INTERIOR AND EXTERIOR). REFER TO COLOR DESIGN SPECIFICATION AND PAINT SPECIFICATION
- 10 CAULK WINDOWS AND RE-PUTTY MUNTINS AT GLAZING AS NEEDED.
- 11 STRIP WAX FROM BRICK FLOORS. CLEAN AND SEAL BRICK.
- 12 PAINT INTERIOR BRICK WALLS. REFER TO COLOR DESIGN SPECIFICATION AND PAINT SPECIFICATION
- 13 SANDBLAST CONCRETE PICNIC TABLES SMOOTH AND REPAINT. SEE PAINT SPECIFICATION.
- 14 INSTALL NEW LITERATURE RACKS AS DIRECTED. (OWNER FURNISHED)
- 15 INSTALL PETWAY STATIONS AS DIRECTED. (OWNER FURNISHED)
- 16 REMOVE UNUSED SURFACE MOUNTED TV AND CABLES AS DIRECTED. PATCH HOLES PRIOR TO PAINTING.
- 17 PRESSURE WASH PICNIC PAVILIONS AND GUARD HOUSE AND PAINT ALL PREVIOUSLY PAINTED SURFACES. SEE PAINT SPECIFICATION.
- 18 REPAIR COPPER GUTTER.
- 19 ALL SALVAGE ITEMS TO BE REMOVED CAREFULLY AND RETURNED TO OWNER.

ITAWAMBA ELECTRICAL NOTES

- A REPLACE CHANDELIER WITH OWNER FURNISHED 8 BULB CHANDELIER FIXTURE. PROVIDE (8) 6 WATT LED CANDELABRA BULBS. MOUNT FIXTURE 9' - 0" A.F.F.
- B REPLACE CHANDELIER WITH OWNER FURNISHED 6 BULB CHANDELIER FIXTURE. PROVIDE (6) 6 WATT LED CANDELABRA BULBS. MOUNT FIXTURE 9' - 0" A.F.F.
- C PROVIDE AND INSTALL A DEDICATED 110V-15AMP CIRCUIT FROM EXISTING PANEL (VERIFY AVAILABLE SPACE IN PANEL) TO VIDEO WALL LOCATION AS SHOWN ON PLANS (VIDEO WALL PROVIDED AND INSTALLED BY OTHERS). FLEXIBLE METAL CONDUIT ALLOWED IN CONCEALED SPACES (PROVIDE GROUND CONDUCTOR). STRAP AS PER NEC.
- D DROP POWER CIRCUIT FROM J-BOX (IN ATTIC SPACE) THRU CEILING WITH 14 GAUGE, 3-CONDUCTOR S/O CORD ON THIS SIDE OF WALL, THEN ROUTE THRU WALL AT 72" A.F.F. ROUTE IN LEAST CONSPICUOUS LOCATION POSSIBLE. STRAP CORD TO WALL AS REQUIRED.
- E TERMINATE S/O CORD ON THIS SIDE OF WALL WITH A STRAIGHT BLADE CONNECTOR, 15 AMP, 125 V, NEMA 5-15R, 2P, 3W, BLACK. PROVIDE 12" PIGTAIL FROM WALL TO END OF CORD.
- F DATA LOCATION AT 72" A.F.F. FOR VIDEO WALL. DATA CABLING PROVIDED AND INSTALLED BY OTHERS.
- G PROVIDE AND INSTALL DATA OUTLET BOX EQUAL TO WIREMOLD SURE-SNAP 400 SERIES (#2348S-51) WITH APPROPRIATE COVER PLATE AT THIS LOCATION FOR INFORMATION KIOSK (KIOSK PROVIDED BY OTHERS), AND/OR WORK DESKS (WORK DESKS PROVIDED BY OTHERS). MOUNT BOX DIRECTLY ABOVE BASE MOULDING. PROVIDE WIREMOLD SERIES 400 RACEWAY #400BAC OR EQUAL. INSTALL RACEWAY IN LEAST CONSPICUOUS LOCATION, SUCH AS IN CORNERS AND ALONG TOP OF BASE MOULDING. AVOID ROUTING ON OPEN WALLS. (DATA CABLE TO BE PROVIDED AND INSTALLED BY OTHERS.)

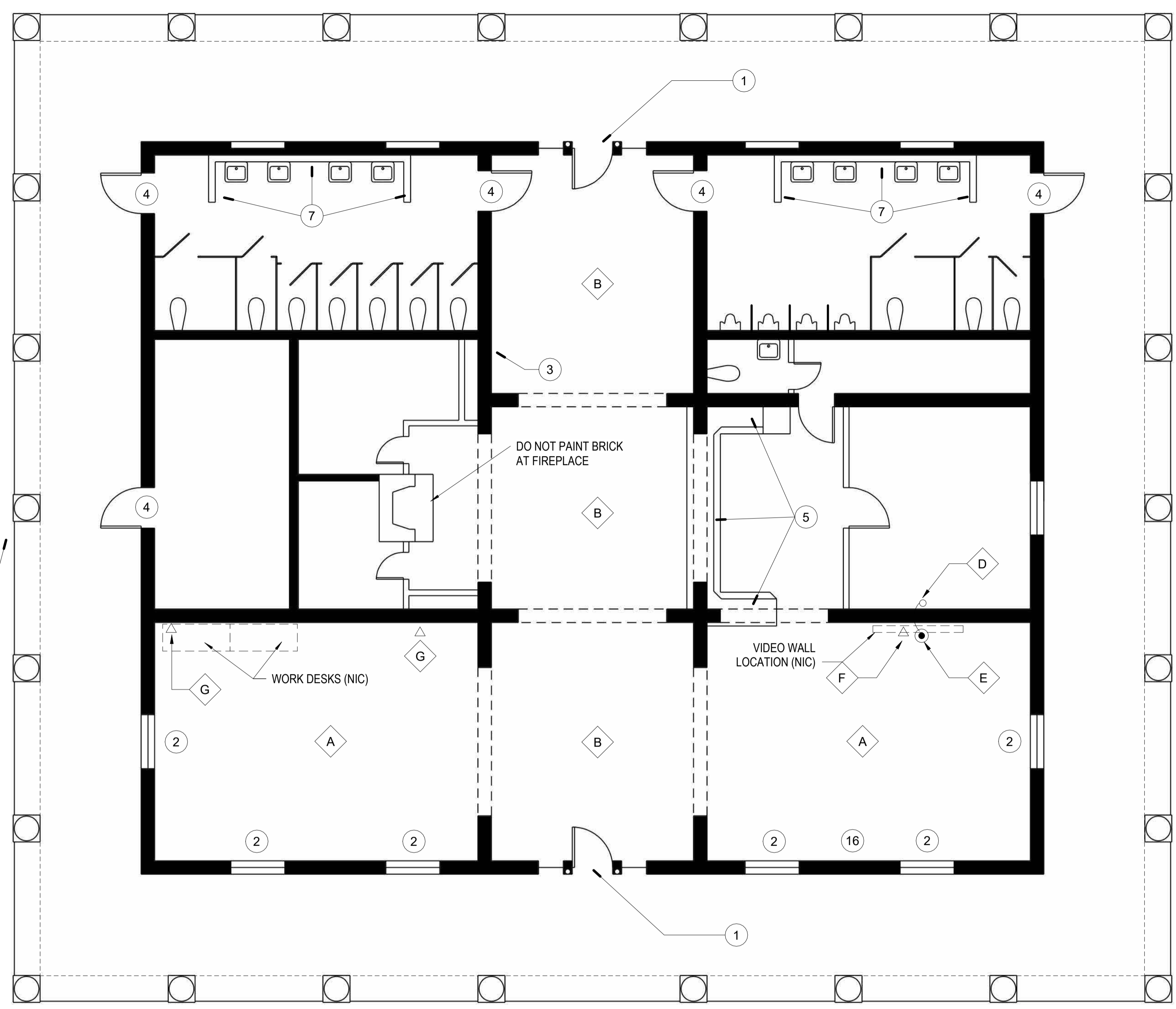

ITAWAMBA WELCOME CENTER FLOOR PLAN
 3/16" = 1'-0"

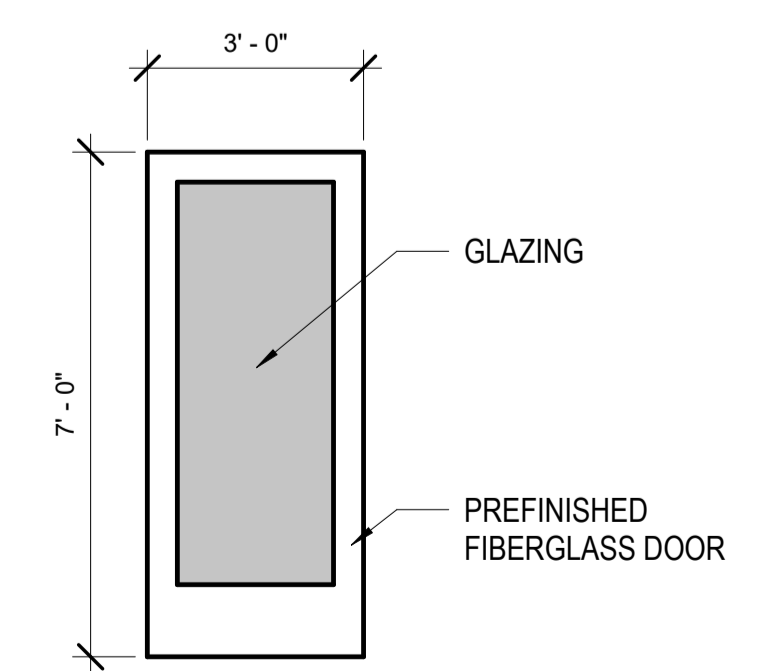
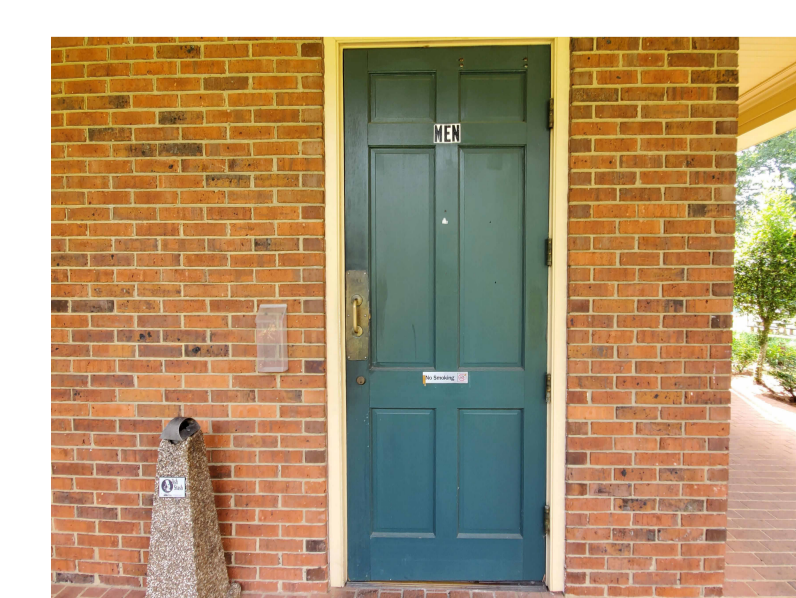
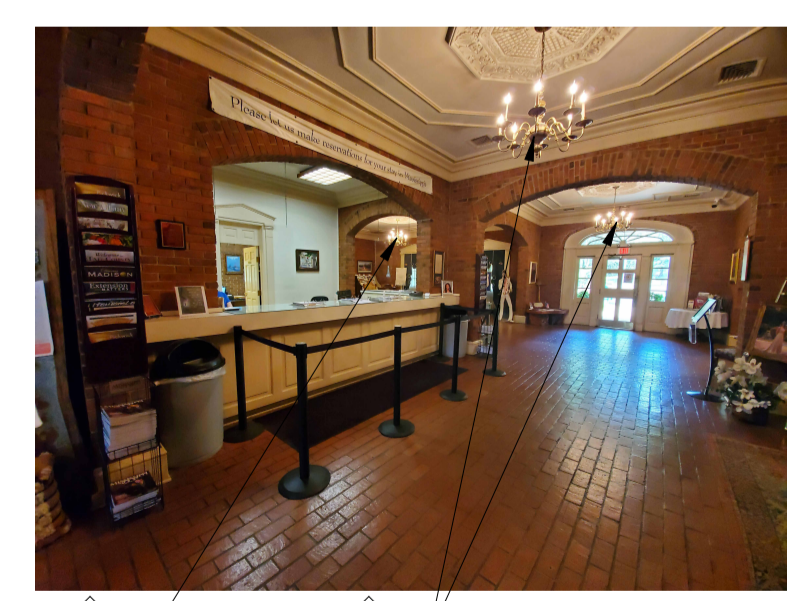
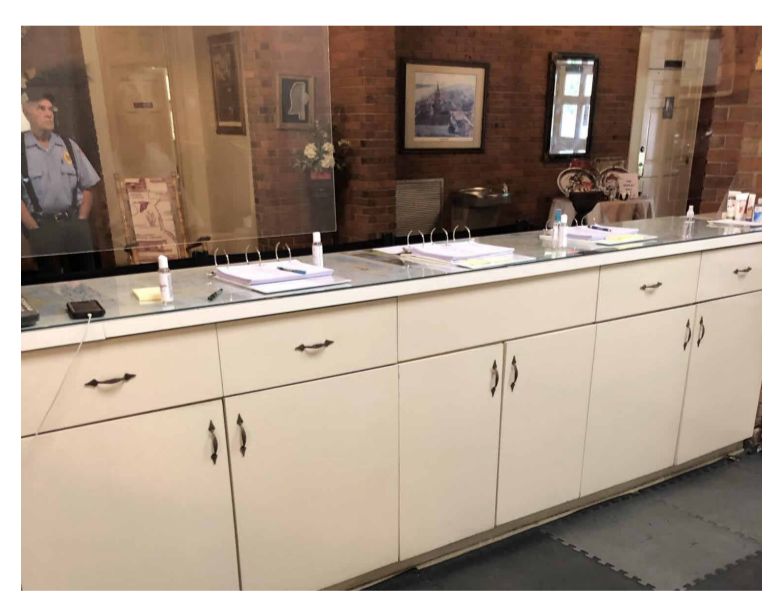
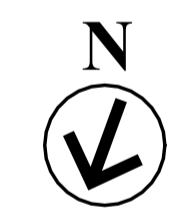
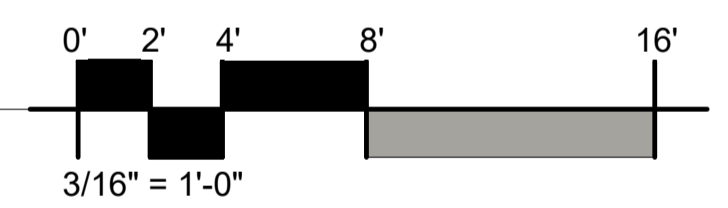

1 ENTRY DOOR ELEVATION
 3/8" = 1'-0"

- CONDUIT DROP
- ▽ DATA OUTLET
- STRAIGHT BLADE CONNECTOR

ELEC/DATA LEGEND
 1/4" = 1'-0"